

# APPLITEC

## SWISS TOOLING

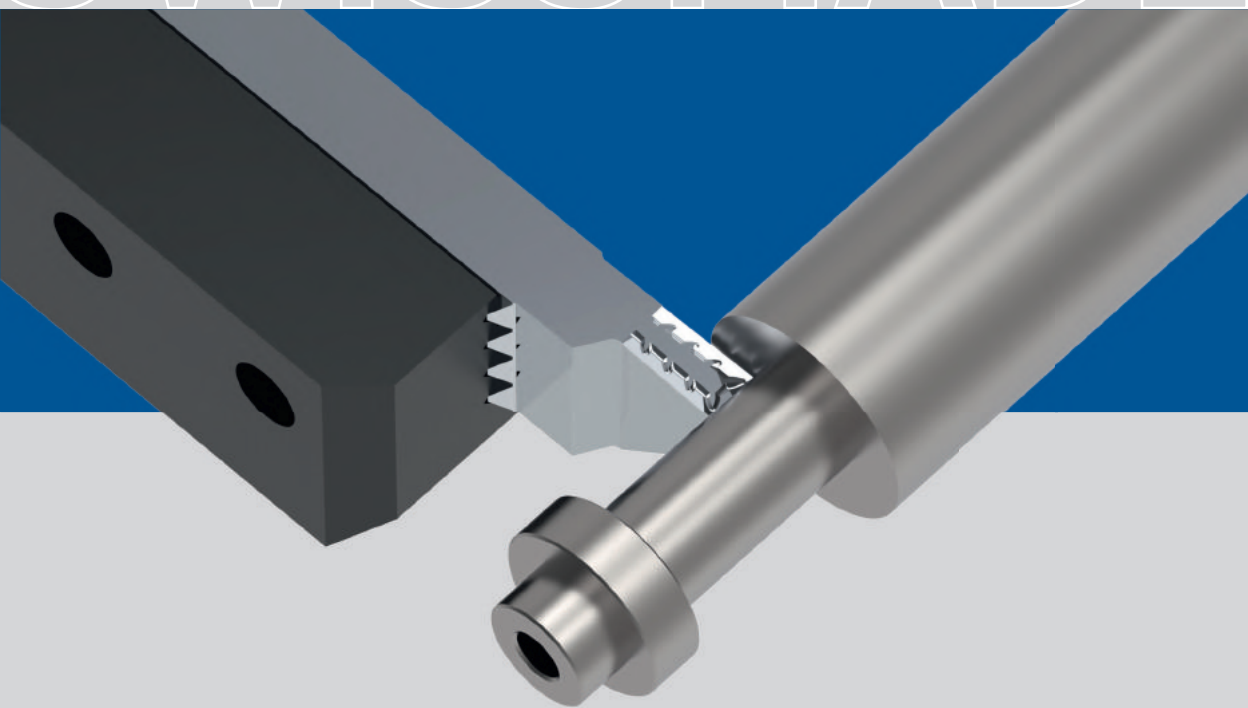

SWISSMADE



EDITION 2022-2024

APPLITEC

**OUTILS DE HAUTES PERFORMANCES  
POUR LE DÉCOLLETAGE  
ET LA MICROMÉCANIQUE**

**HOCHLEISTUNGSWERKZEUGE  
FÜR DREHAUTOMATEN  
UND MIKROMECHANIK**

**HIGH PERFORMANCE TOOLING  
FOR AUTOMATIC LATHES  
AND MICROMECHANICS**



	<b>TOP-LINE</b>		<b>1</b>
	<b>TOP-WATCH</b>		<b>2</b>
	<b>PRO-LINE</b>		<b>3</b>
	<b>ECO-LINE</b>		<b>4</b>
	<b>TRIO-LINE</b>		<b>5</b>
	<b>TURN-LINE</b>		<b>6</b>
	<b>ISO-LINE</b>		<b>7</b>
	<b>EVOCUT-LINE</b>		<b>8</b>
	<b>CUT-LINE</b>		<b>9</b>
	<b>IN-LINE</b>		<b>10</b>
	<b>SWITCH-LINE</b>	<b>new</b>	<b>11</b>
	<b>MODU-LINE</b>		<b>12</b>
	<b>TOOLING-LINE</b>		<b>13</b>
	<b>MICRO-LINE</b>		<b>14</b>
	<b>CIRCO-LINE</b>		<b>15</b>
	<b>JET-LINE</b>	<b>new</b>	<b>16</b>
	<b>INDEX</b>		<b>17</b>

APPLITEC



**INFO**

Nuances et paramètres de coupe  
Sorten und Schnittwerte  
Grades and machining data

> **1.02****710 / 720**

Pour machines à cames  
Für kurvengesteuerte Maschinen  
For cam driven machines

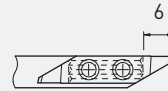
> **1.12****730 / 740**

**Main series**  
**Small type**

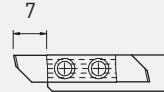
> **1.24****750 / 760**

**Main series**  
**Large type**

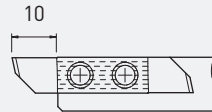
> **1.68****770 / 780****7050 / 7060****W750 / W760****POLYGONAL  
INTERFACE****HSK****740Z / 760Z****TORNOS****SCHÜTTE**

Tronçonnage de grande capacité et ébauches larges pour  
profilage + porte-outils spéciaux

Abstechen für grössere Durchmesser und breite Rohlinge  
für Profilschleifen + Sonderwerkzeughalter

High capacity parting off and wide blanks for profiling +  
special tool holders

> **1.132**

Pièces de rechange  
Ersatzteile  
Spare parts

> **1.166**

# TOP-LINE

Codification des plaquettes TOP-Line série 700

WSP-Bezeichnungssystem für TOP-Line 700 Serie

Inserts designation key for TOP-Line 700 series



Dimension  
Abmessung  
Dimension

Rayon  
Radius  
Radius

Nuance  
Sorte  
Grade

Géométrie de coupe / Brise-copeaux / Particularités  
 Schneidgeometrie / Spanbrecher / Sondereigenschaften  
 Cutting geometry / Chip breaker / Special features

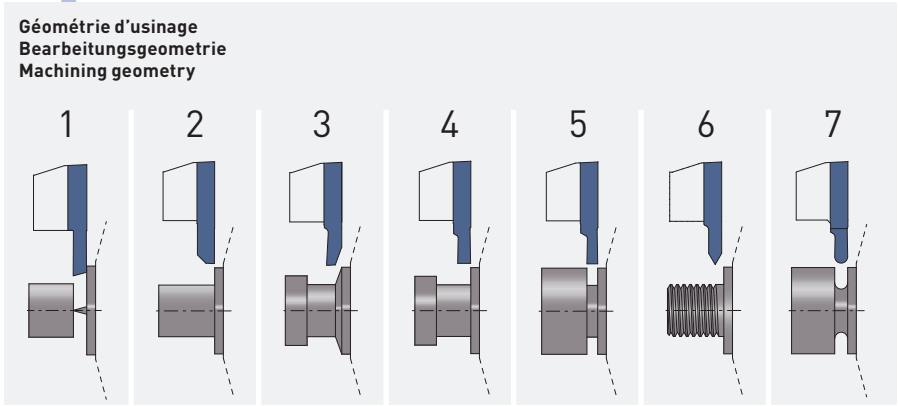

Gamme de produit  
 Produktserie  
 Product series

défini la compatibilité des plaquettes avec le porte-outil  
 bestimmt die WSP und Halter Kompatibilität  
 shows the inserts and holder compatibility

L = 1, 3, 5, 7 (chiffre impair / ungerade Zahl / uneven number)

R = 2, 4, 6, 8 (chiffre pair / gerade Zahl / even number)

L 710 | R 720

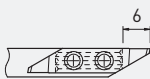

pour machines à cames  
 für kurvengesteuerte Maschinen  
 for cam driven machines

L 730 | R 740

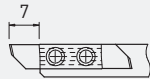

main series  
 small type

L 750 | R 760

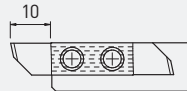

main series  
 large type

L 770 | R 780

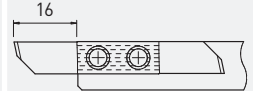

tronçonnage uniquement  
 nur für abstechen  
 only for parting off

Applitec série 700  
 Applitec 700 Serie  
 Applitec 700 series

Système de serrage à denture décalée avec 2 vis de fixation  
 Spannsystem mit 2 Schrauben und verschobener Verzahnung  
 Shifted teeth clamping system with 2 screws

L'outil de référence pour le décolletage

Hochwertiges Wendeplattensystem für Langdrehautomaten

Top class turning tool for automatic lathes

700 Series

## 100% rigid!

Système de serrage Applitec à denture décalée  
 Applitec-Spannsystem mit verschobener Verzahnung  
 Applitec clamping system with shifted teeth

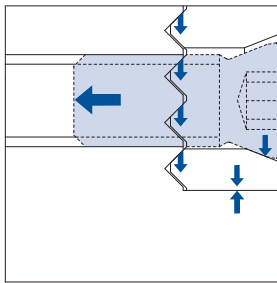
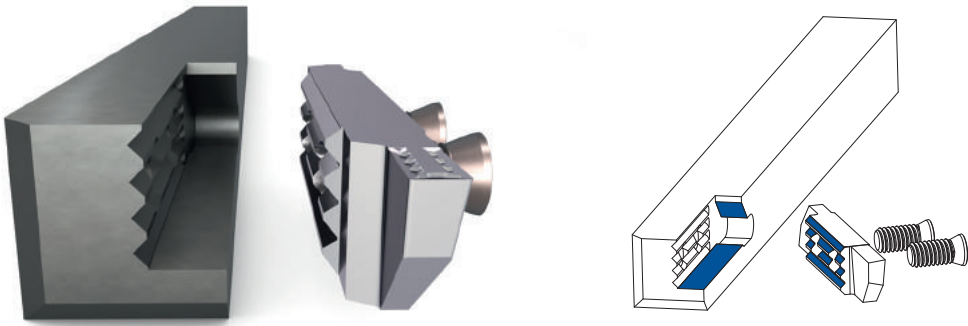

**Serrage standard (A)**  
**Standard Spannsystem (A)**  
**Standard clamping system (A)**

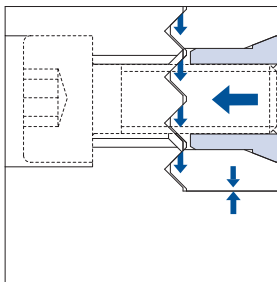
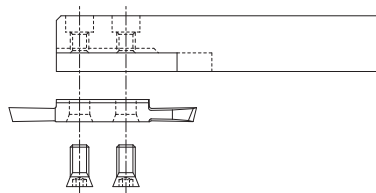

**Serrage type B\***  
**Spannsystem Typ B\***  
**Clamping system type B\***

ajouter -B après le numéro d'article  
 -B nach der Artikelreferenz hinzufügen  
 add -B after the article number

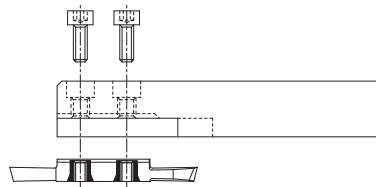

Changement de la plaquette possible dans la machine, sans démontage du porte-outil  
 WSP-Austauschmöglichkeit in der Maschine ohne Halterausbau  
 The insert can be changed in the machine without removing the tool holder

## 700-ZX geometries

Très bonne maîtrise du copeau  
pour matières difficiles

Sehr gute Spankontrolle für  
schwierige Werkstoffe

Very efficient chip control for  
difficult materials



Multitude de géométries possibles

Mehrere mögliche Spangeometrien

Many different cutting geometries are possible





## 700-honed



Géométrie positive 5° avec arête de coupe renforcée (honnée)  
Meilleure durée de vie dans l'usinage des matériaux abrasifs (aciers au carbone, aciers alliés)

Positive Geometrie 5° mit verstärkte Schneidkante (gehont)  
Bessere Standzeit für die Bearbeitung von abrasive Materialien (Kohlenstoff Stahl, legierter Stahl)

Positive geometry 5° with reinforced cutting edge (honed)  
Better tool life for abrasive materials (carbon steel, alloy steel)

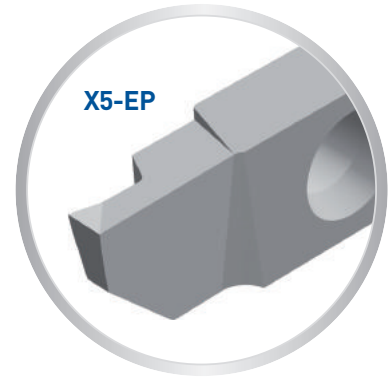





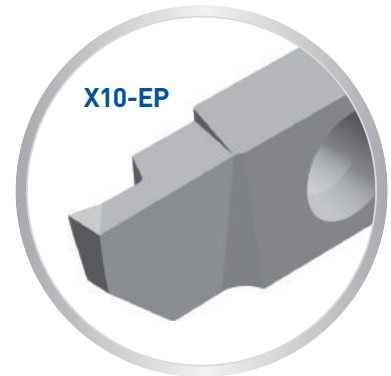

Géométrie positive 10° avec arête de coupe renforcée (honnée)  
Meilleure durée de vie dans l'usinage des matériaux tenace (acier inox, inox martensitique)

Positive Geometrie 10° mit verstärkte Schneidkante (gehont)  
Bessere Standzeit für die Bearbeitung von zähe Materialien (Rostfreier Stahl, martensitische Rostfreier Stahl)

Positive geometry 10° with reinforced cutting edge (honed)  
Better tool life for tough materials (stainless steel, martensitic steel)



Géométries de coupe Spanformgeometrien Cutting geometries		Acier de décolletage Automatenstahl Free-cutting steel	Acier Stahl Steel	Acier inoxydable Rostfreistahl Stainless steel	Aluminium	Titane Titan Titanium	Laiton, bronze Messing, Bronze Brass, bronze	Cuivre Kupfer Copper	★	1 <sup>er</sup> choix 1. Wahl 1 <sup>st</sup> choice
									☆	Recommandé Empfohlen Recommended
									☑	Pour pièces fragiles de très petits diamètres Für empfindliche und sehr kleine Werkstücke For fragile and very small work pieces
	0°	★	☑	☑	☑	☑	★	☑	★	Permet un réaffûtage aisé Erlaubt einfaches Nachschleifen Allows easy regrinding
	X4°	★	★	★	☑	☑		☑	★	Réduit l'effort de coupe, réaffûtable Reduziert Schneidkräfte, nachschleifbar Decreases cutting force, allows regrinding
	XF	☆	★	★					☆	Pour matières difficiles (pointe renforcée) Für schwierige Werkstoffe (verstärkte Spitze) For difficult materials (reinforced point)
	X12°			☆	★	★		★	★	Très bonne maîtrise du copeau Sehr gute Spankontrolle Very efficient chip control
	X25°			☆	★	☆		☆	☆	Pour matières collantes faisant de très longs copeaux Für klebrige Werkstoffe mit sehr langen Spänen For long chipping sticky materials
	U	☆	☆	☆						Pour resserrer le copeau, réaffûtage aisé Für Spanversmälnerung, einfaches Nachschleifen To narrow the chips, easy regrinding
	ZU8	★	★	★	☆ <5% Si	☆	☆		☆	Très bonne maîtrise du copeau (arête de coupe honée) Sehr gute Spankontrolle (gehonte Schneidkante) Very efficient chip control (honed edge) f min: 0.02 mm/U

## Conseils d'utilisation

## Anwendungsempfehlungen













## Application recommendations

## Tournage

## Drehen

## Turning

## 700 Series

Géométries de coupe Spannformgeometrien Cutting geometries		Acier de décolletage Automatenstahl Free-cutting steel	Acier Stahl Steel	Acier inoxydable Rostfreistahl Stainless steel	Aluminium	Titane Titan Titanium	Laiton, bronze Messing, Bronze Brass, bronze	Cuivre Kupfer Copper	★	1 <sup>er</sup> choix 1. Wahl 1 <sup>st</sup> choice
									☆	Recommandé Empfohlen Recommended
									⊗	Pour pièces fragiles de très petits diamètres Für empfindliche und sehr kleine Werkstücke For fragile and very small work pieces
	0°	★	⊗	⊗	⊗	⊗	★	⊗		Permet un réaffûtage aisé Erlaubt einfaches Nachschleifen Allows easy regrinding
	X	★	★	★	★	★		★		Très bonne maîtrise du copeau Sehr gute Spankontrolle Very efficient chip control
	X5-EP	★	★	☆						Très bonne maîtrise du copeau (arête de coupe honée) Sehr gute Spankontrolle (gehonte Schneidkante) Very efficient chip control (honed edge) f min: 0.02 mm/U
	X10-EP	☆	☆	★	☆	☆				Très bonne maîtrise du copeau (arête de coupe honée) Sehr gute Spankontrolle (gehonte Schneidkante) Very efficient chip control (honed edge) f min: 0.02 mm/U
	VX800	★	★	☆	☆	☆		☆		Très bonne maîtrise du copeau Sehr gute Spankontrolle Very efficient chip control
	VX8°	★	★	☆	☆	☆		☆		Très bonne maîtrise du copeau Sehr gute Spankontrolle Very efficient chip control
	VUX	☆	☆	★	☆	★		☆		Roule-copeau bidirectionnel Bidirektionaler Spanroller Bi-directional chip-breaker
	VX15°	☆		☆	★	★		★		Très bonne maîtrise du copeau Sehr gute Spankontrolle Very efficient chip control
	VS	☆		☆	⊗	⊗		⊗		Brise-copeau pour usinage léger en finition Spanbrecher für leichte Schlichtbearbeitung Chip-breaker for light finishing operation
	ZX10	★	★	★	☆ <5% Si	☆	☆			Très bonne maîtrise du copeau Sehr gute Spankontrolle Very efficient chip control f min: 0.02 mm/U
	ZX17			☆	★ <5% Si	★		★		Très bonne maîtrise du copeau Sehr gute Spankontrolle Very efficient chip control f min: 0.02 mm/U
	ZX25			☆	★ <5% Si	★		★		Très bonne maîtrise du copeau Sehr gute Spankontrolle Very efficient chip control f min: 0.02 mm/U
	ZXT	★	★	★	☆ <5% Si	☆	☆			Très bonne maîtrise du copeau Sehr gute Spankontrolle Very efficient chip control f min: 0.02 mm/U

<h3>TiAlN</h3> <p>μK20 + revêtement PVD μK20 + PVD Beschichtung μK20 + PVD coating</p>	<h3>TiAlX</h3> <p>μK20 + revêtement PVD μK20 + PVD Beschichtung μK20 + PVD coating</p>	<h3>TiN</h3> <p>μK20 + revêtement PVD μK20 + PVD Beschichtung μK20 + PVD coating</p>
<ul style="list-style-type: none"> <li>excellente nuance universelle</li> <li>1<sup>er</sup> choix pour l'usinage des aciers, aciers inoxydables et alliages de titane</li> <li>très bonne résistance à la température</li> </ul>	<ul style="list-style-type: none"> <li>nuance très résistante à l'usure et à la température, recommandée pour l'usinage des matières suivantes: Inox 304, 316L, 317L, 904, Phynox</li> <li>aciers alliés contenant: Chrome Nickel, Vanadium, Molybdène, ...</li> </ul>	<ul style="list-style-type: none"> <li>nuance pour l'usinage des matières peu résistantes qui créent des arêtes rapportées</li> <li>très faible coefficient de frottement</li> <li>à éviter pour l'usinage du titane</li> </ul>
<ul style="list-style-type: none"> <li>beste Universalsorte</li> <li>für die Bearbeitung von Stahl, rostfreier Stahl und Titanlegierungen bestens geeignet</li> <li>sehr gute Warmfestigkeit</li> </ul>	<ul style="list-style-type: none"> <li>sehr verschleissfeste und temperaturbeständige Sorte. Für folgende Materialien empfohlen: Inox 304, 316L, 317L, 904, Phynox</li> <li>legierter Stahl enthaltend: Chrom-Nickel, Vanadium, Molybdän, ...</li> </ul>	<ul style="list-style-type: none"> <li>Sorte für die Bearbeitung von weichen Werkstoffen mit Tendenz zur Bildung von Aufbauschnitten</li> <li>sehr geringer Reibwert</li> <li>für die Bearbeitung von Titan nicht geeignet</li> </ul>
<ul style="list-style-type: none"> <li>best universal grade</li> <li>first choice for steel, stainless steel and titanium alloys machining</li> <li>very good heat resistance</li> </ul>	<ul style="list-style-type: none"> <li>very wear and high temperature resistant grade. Recommended for following material: Inox 304, 316L, 317L, 904, Phynox</li> <li>alloy steel containing: Chrome-nickel, Vanadium, Molybdenum, ...</li> </ul>	<ul style="list-style-type: none"> <li>grade for the machining of low resistance materials which creates build-up edge</li> <li>very low friction ratio</li> <li>not suitable for titanium machining</li> </ul>

<h3>LOX</h3> <p>μK20 + revêtement PVD μK20 + PVD Beschichtung μK20 + PVD coating</p>	<h3>N (μK20)</h3> <p>non revêtu unbeschichtet uncoated</p>
<ul style="list-style-type: none"> <li>nuance résistante à l'usure et à la température, destinée à l'usinage des matières suivantes: Inox, Titane, alliages à base de Nickel, Chrome Cobalt, les matières avec une dureté supérieure à &gt; 50HRC</li> <li>bonne alternative pour l'usinage des aciers de construction types ETG88, ETG100, 36SMnPb14</li> </ul>	<ul style="list-style-type: none"> <li>supporte les coupes interrompues et autres conditions d'usinage défavorables</li> </ul>
<ul style="list-style-type: none"> <li>verschleissfeste und temperaturbeständige Sorte. Für folgende Materialien empfohlen: Inox, Titan, Nickellegierungen, Chrom-Kobalt, Materialien härter als &gt; 50HRC</li> <li>gute Alternative für die Bearbeitung von Baustähle Typ ETG88, ETG100, 36SMnPb14</li> </ul>	<ul style="list-style-type: none"> <li>für unterbrochene Schnitte und andere ungünstige Bearbeitungsbedingungen geeignet</li> </ul>
<ul style="list-style-type: none"> <li>wear and high temperature resistant grade. Recommended for following materials: inox, titanium, nickel alloys, materials harder than &gt; 50HRC</li> <li>good alternative for machining of structural steels type ETG88, ETG100, 36SMnPb14</li> </ul>	<ul style="list-style-type: none"> <li>suitable for interrupted cut and other unfavourable machining conditions</li> </ul>

Nuances micro-grain à dureté élevée

Verschleissfeste Feinkornsorten

Wear resistant micro-grain grades

μK 10

**HTA**

μK10 + revêtement PVD  
μK10 + PVD Beschichtung  
μK10 + PVD coating

- nuance très résistante à l'usure
- pour l'usinage en finition dans des conditions favorables des aciers, aciers inoxydables et alliages de titane

- sehr verschleissfeste Sorte
- für die Feinbearbeitung von Stahl, rostfreiem Stahl und Titanlegierungen bei guten Bearbeitungsbedingungen

- very wear resistant grade
- for light machining of steel, stainless steel and titanium alloys under favourable machining conditions

**HTAX**

μK10 + revêtement PVD  
μK10 + PVD Beschichtung  
μK10 + PVD coating

- nuance très résistante à l'usure et à la température, pour l'usinage en finition avec faibles avances de petites pièces, recommandée pour l'usinage des matières suivantes: Inox 304, 316L, 317L, 904, Phynox
- aciers alliés contenant: Chrome Nickel, Vanadium, Molybdène, ...

- sehr verschleissfeste und temperaturbeständige Sorte. Für Feinbearbeitung von kleinen Teilen mit geringer Vorschub. Für folgende Materialien empfohlen: Inox 304, 316L, 317L, 904, Phynox
- legierter Stahl enthaltend: Chrom-Nickel, Vanadium, Molybdän, ...

- very wear and high temperature resistant grade. For light machining of small parts with low cutting feed. Recommended for following material: Inox 304, 316L, 317L, 904, Phynox
- alloy steel containing: Chrome-nickel, Vanadium, Molybdenum, ...

**HTiN**

μK10 + revêtement PVD  
μK10 + PVD Beschichtung  
μK10 + PVD coating

- nuance pour l'usinage en finition des matières peu résistantes qui créent des arêtes rapportées
- très faible coefficient de frottement
- à éviter pour l'usinage du titane

- Sorte für die Feinbearbeitung von weichen Werkstoffen mit Tendenz zur Bildung von Aufbauschneiden
- sehr geringer Reibwert
- für die Bearbeitung von Titan nicht geeignet

- grade for light machining of low resistance materials which creates build-up edge
- very low friction ratio
- not suitable for titanium machining

**HAS**

μK10 + revêtement PVD  
μK10 + PVD Beschichtung  
μK10 + PVD coating

- nuance pour métaux non ferreux
- très faible coefficient de frottement
- 1<sup>er</sup> choix pour l'usinage des aluminiums jusqu'à 5% Si, des cuivres et titanes faiblement alliés

- Sorte für Nichteisenmetalle
- sehr geringer Reibwert
- für die Bearbeitung von Aluminium bis 5% Si, Kupfer und niedriglegiertem Titan bestens geeignet

- grade for non-ferrous materials
- very low friction ratio
- first choice for aluminium up to 5% Si, copper and low alloyed titanium

**HN (μK10)**

non revêtu  
unbeschichtet  
uncoated

- nuance micro-grain très résistante à l'usure
- recommandé pour l'usinage du titane faiblement allié
- déconseillé en cas de coupe interrompue et autres conditions d'usinage défavorables

- verschleissfeste Feinkornsorte
- für die Bearbeitung von niedrig legiertem Titan empfehlenswert
- für unterbrochene Schnitte und andere ungünstige Bearbeitungsbedingungen nicht geeignet

- wear resistant micro-grain grade
- suitable for the machining of low alloyed titanium
- not suitable for interrupted cut and other unfavourable machining conditions

## Paramètres de coupe indicatifs

## Empfohlene Schnittwerte

## Standard machining data

Matière Werkstoff Material	Tournage Drehen Turning			Tronçonnage Abstechen Parting off		
	VC	Prof. de passe Schnitttiefe Depth of cut	Avance Vorschub Feed	VC	Largeur de coupe Abstechbreite Cutting width	Avance Vorschub Feed
	(m/min)	(mm)	(mm/U)	(m/min)	(mm)	(mm/U)
Acier de décolletage Automatenstahl Free-cutting steel <b>P</b>	120 - 200	0.05 - 1.0 1.0 - 4.0	0.01 - 0.15 0.05 - 0.25	80 - 150	0.50 - 1.50 1.50 - 3.50	0.01 - 0.08 0.03 - 0.15
Acier Stahl < 600 N/mm <sup>2</sup> <b>P</b>	80 - 160	0.05 - 1.0 1.0 - 4.0	0.01 - 0.15 0.05 - 0.25	70 - 120	0.50 - 1.50 1.50 - 3.50	0.01 - 0.06 0.03 - 0.12
Acier Stahl < 800 N/mm <sup>2</sup> <b>P</b>	60 - 120	0.05 - 1.0 1.0 - 4.0	0.01 - 0.10 0.05 - 0.20	60 - 100	0.50 - 1.50 1.50 - 3.50	0.01 - 0.05 0.03 - 0.10
Acier Stahl > 800 N/mm <sup>2</sup> <b>P</b>	50 - 100	0.05 - 1.0 1.0 - 3.0	0.01 - 0.08 0.05 - 0.15	40 - 80	0.50 - 1.50 1.50 - 3.50	0.01 - 0.04 0.03 - 0.08
Acier inoxydable Rostfreistahl Stainless steel <b>M</b>	60 - 120	0.05 - 1.0 1.0 - 3.0	0.01 - 0.08 0.05 - 0.15	60 - 100	0.50 - 1.50 1.50 - 3.50	0.01 - 0.04 0.03 - 0.08
Aluminium Si <12% <b>N</b>	200 - 1000	0.05 - 1.0 1.0 - 4.0	0.01 - 0.20 0.05 - 0.40	180 - 400	0.50 - 1.50 1.50 - 3.50	0.01 - 0.10 0.03 - 0.20
Aluminium Si >12% <b>N</b>	180 - 800	0.05 - 1.0 1.0 - 4.0	0.01 - 0.20 0.05 - 0.40	150 - 300	0.50 - 1.50 1.50 - 3.50	0.01 - 0.10 0.03 - 0.20
Cuivre, laiton, bronze Kupfer, Messing, Bronze Copper, brass, bronze <b>N</b>	100 - 500	0.05 - 1.0 1.0 - 4.0	0.01 - 0.20 0.05 - 0.35	100 - 300	0.50 - 1.50 1.50 - 3.50	0.01 - 0.10 0.03 - 0.20
Titane Titan Titanium <b>S</b>	30 - 70	0.05 - 1.0 1.0 - 4.0	0.01 - 0.08 0.05 - 0.15	30 - 50	0.50 - 1.50 1.50 - 3.50	0.01 - 0.03 0.03 - 0.06

**Indications pour premier réglage**  
**Hinweise für die erste Einrichtung**  
**Indications for first setting**

<b>Ébauche</b> <b>Schruppen</b> <b>Roughing</b>	<b>Finition</b> <b>Schlichten</b> <b>Finishing</b>
<ul style="list-style-type: none"> <li>• vitesse de coupe moyenne</li> <li>• avance élevée</li> </ul>	<ul style="list-style-type: none"> <li>• vitesse de coupe élevée</li> <li>• avance faible</li> </ul>
<ul style="list-style-type: none"> <li>• durchschnittliche Schnittgeschwindigkeit</li> <li>• hohe Schnittgeschwindigkeit</li> </ul>	<ul style="list-style-type: none"> <li>• hohe Schnittgeschwindigkeit</li> <li>• niedriger Vorschub</li> </ul>
<ul style="list-style-type: none"> <li>• average cutting speed</li> <li>• high cutting speed</li> </ul>	<ul style="list-style-type: none"> <li>• high cutting speed</li> <li>• low cutting feed</li> </ul>

**Remarques importantes**  
**Wichtige Bemerkungen**  
**Important remarks**

- en raison des limites de la machine, il n'est souvent pas possible d'atteindre les vitesses de coupe préconisées
- les outils Applitec sont spécialement développés pour permettre de hautes performances, même dans des conditions de coupe défavorables
- des applications non préconisées dans le tableau ci-contre peuvent également s'avérer efficaces

- wegen begrenzter Maschinenleistung ist es oft nicht möglich, die vorgeschlagenen Schnittgeschwindigkeiten zu erreichen
- Applitec Werkzeuge sind besonders dazu entwickelt, um sogar bei ungünstigen Schnittdaten leistungsfähig zu sein
- die in der nebenstehender Tabelle nicht erwähnten Anwendungsfälle können sich auch effizient erweisen

- in many cases, it is impossible to reach the recommended cutting speed, due to the machine limits
- Applitec tools are especially designed to be efficient even in bad cutting conditions
- applications not mentioned in the opposite table can also be efficient

L		R	
Type	Page	Type	Page
710	1.14	720	1.14
710-NOVIBRA	1.15	721	1.16
711	1.16	721-EP	1.23
711-EP	1.23	722	1.17
712	1.17	723-30	1.18
713-30	1.18	723-45	1.19
713-45	1.19	723-60	1.20
713-60	1.20	724	1.21
714	1.21	726	1.22
716	1.22		

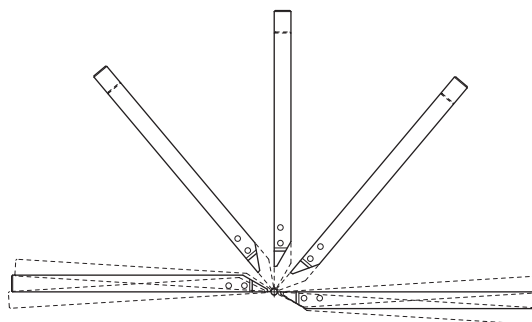

Porte-outils et plaquettes pour machines à cames  
 Halter und WSP für kurvengesteuerte Maschinen  
 Tool holders and inserts for cam driven machines

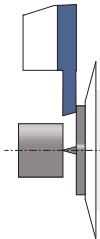
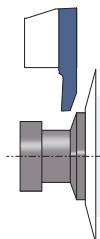
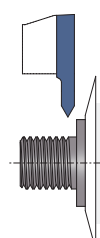

		<b>710 / 720</b> Porte-outils Halter Holders	> <b>1.14</b>
	<b>711 / 721</b> Tronçonnage Abstechen Parting off		> <b>1.16</b>
		<b>712 / 722</b> Tournage avant Vorwärts drehen Front turning	> <b>1.17</b>
	<b>713 / 723</b> Tournage arrière Rückwärts drehen Back turning		> <b>1.18</b>
		<b>714 / 724</b> Fonçage-tournage Einstechen und drehen Grooving and turning	> <b>1.21</b>
	<b>716 / 726</b> Filetage Gewinde drehen Threading		> <b>1.22</b>
		Plaquette ébauche WSP-Rohling Blank insert	> <b>1.23</b>

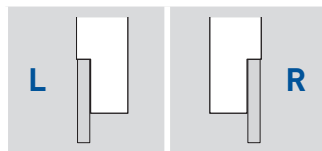
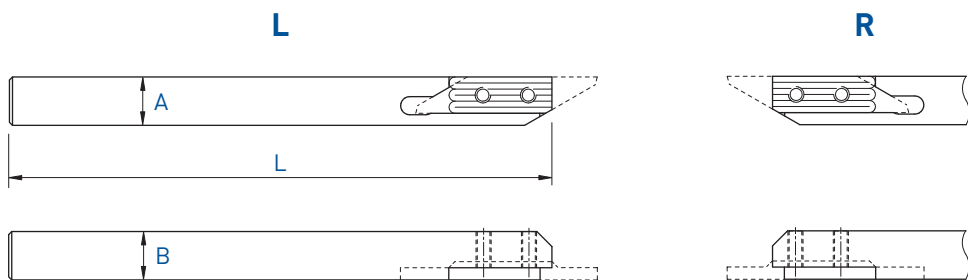

A x B	L	Serrage Spannsystem Clamping	Art. N°	Art. N°
6 x 6	115	A	<b>710-6</b>	-
7 x 7	115	A	<b>710-7</b>	<b>720-7</b>
8 x 8	115	A	<b>710-8</b>	<b>720-8</b>
8 x 8	140	A	<b>710-8-140</b>	-
10 x 10	115	A	<b>710-10</b>	<b>720-10</b>
12 x 12	130	A	<b>710-12</b>	<b>720-12</b>



Chaque support est livré avec vis et clé.  
 Jeder Halter wird mit Spannschraube(n) und Schlüssel geliefert.  
 Screw(s) and key are included with each tool holder.

Porte-outils en métal lourd anti-vibratoire  
 Schwingungsdämpfende Schwermetallhalter  
 Low vibration heavy metal holders

710-NOVIBRA

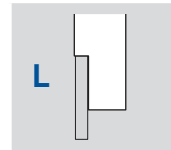
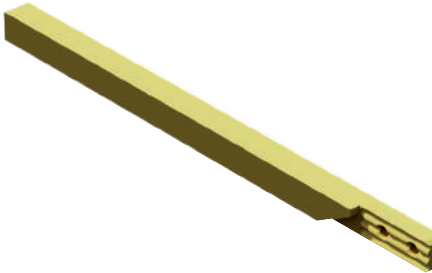
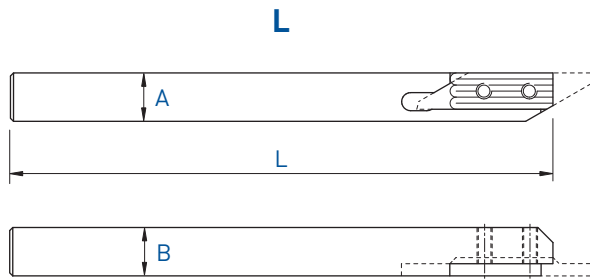

A x B	L	Serrage Spannsystem Clamping	Art. N°
6 x 6	115	A	710-6-NOVIBRA
7 x 7	115	A	710-7-NOVIBRA
8 x 8	115	A	710-8-NOVIBRA



Chaque support est livré avec vis et clé.  
 Jeder Halter wird mit Spannschraube(n) und Schlüssel geliefert.  
 Screw(s) and key are included with each tool holder.

L

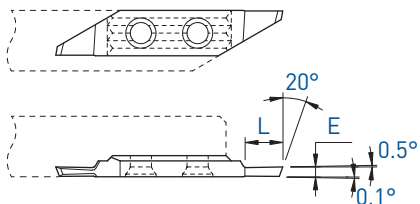

R

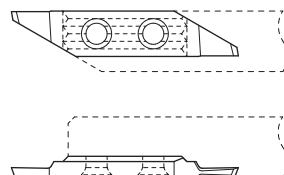

L



R



E	L	Art. N°	L			R									
			TiAlN	TiN	N (µk20)	HTA	HTiN	HN (µk10)							
0.5	2	711-0.5	■	■	■	■	□	■	-	■	■	■			
0.8	3	711-0.8	■	■	■	■	■	■	721-0.8	■	■	■			
0.9	3	711-0.9	■	■	■	■	□	■	-						
1.0	4	711-1.0	■	■	■	■	■	■	721-1.0	■	■	■	■	□	■
1.1	4	711-1.1	■	■	■	■	■	■	-						
1.2	5	711-1.2	■	■	■	■	■	■	721-1.2	■	■	■	■	□	■
1.3	5	711-1.3	■	■	■	■	□	■	-						
1.4	5	711-1.4	■	■	■				-						
1.5	6.5	711-1.5	■	■	■	■	■	■	721-1.5	■	■	■	■	□	■
1.8	6.5	711-1.8	■	■	■	■	□	■	721-1.8	■	■	■			
2.0	6.5	711-2.0	■	■	■				721-2.0	■	■	■			

Tournage avant  
Vorwärts drehen  
Front turning

712 / 722

L

R

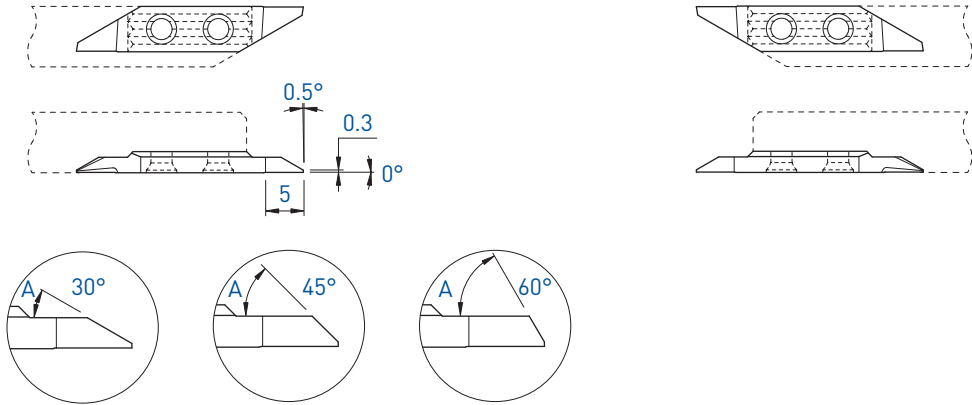

A	Art. N°	L						R						
		TiAlN	TiN	N (µk20)	HTA	HTiN	HN (µk10)	Art. N°	TiAlN	TiN	N (µk20)	HTA	HTiN	HN (µk10)
30°	712-30	■	■	■	■	□	■	722-30	■	■	■	■	□	■
45°	712-45	■	■	■	■	■	■	722-45	■	■	■	■	□	■
60°	712-60	■	■	■	■	■	■	722-60	■	■	■	■	□	■

# TOP-LINE

Tournage arrière  
Rückwärts drehen  
Back turning

713-30° / 723-30°

L

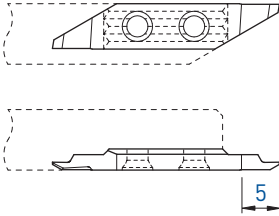

R

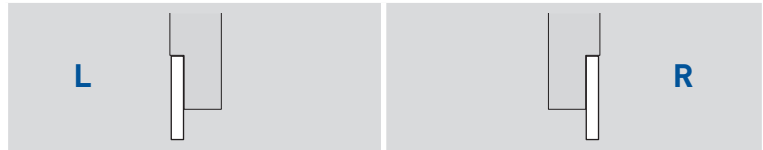
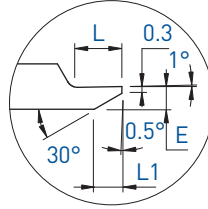
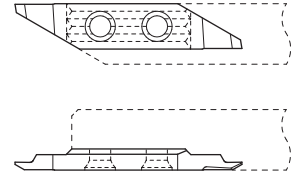

E	L	L1	Art. N°	L			R								
				TiAlN	TiN	N (µk20)	HTA	HTiN	HN (µk10)	Art. N°	TiAlN	TiN	N (µk20)	HTA	HTiN
0.8	1.6	0.85	713-30-0.8	■	■	■			723-30-0.8	■	■	■	■	□	■
0.9	1.6	1.05	713-30-0.9	■	■	■			-						
1.0	2.0	1.2	713-30-1.0	■	■	■	■	□	723-30-1.0	■	■	■	■	□	■
1.1	2.0	1.4	713-30-1.1	■	■	■			-						
1.2	2.5	1.55	713-30-1.2	■	■	■			723-30-1.2	■	■	■			
1.3	2.5	1.7	713-30-1.3	■	■	■			-						
1.4	3.0	1.9	713-30-1.4	■	■	■			-						
1.5	3.0	2.1	713-30-1.5	■	■	■	■	■	723-30-1.5	■	■	■	■		
1.8	4.0	2.6	713-30-1.8	■	■	■			723-30-1.8	■	■	■			
2.0	4.0	2.9	713-30-2.0	■	■	■	■	■	723-30-2.0	■	■	■			

Tournage arrière  
 Rückwärts drehen  
 Back turning

713-45° / 723-45°

L

R

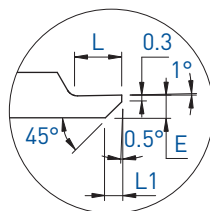
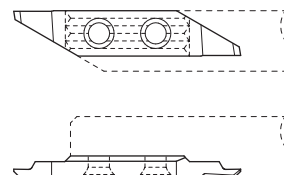
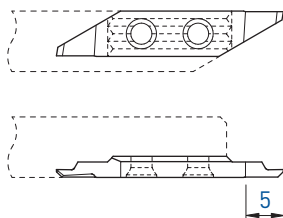

E	L	L1	Art. N°	TiAlN	TiN	N (µk20)	HTA	HTiN	HN (µk10)	Art. N°	TiAlN	TiN	N (µk20)	HTA	HTiN	HN (µk10)
0.8	1.6	0.5	713-45-0.8	■	■	■	■	□	■	723-45-0.8	■	■	■			
0.9	1.6	0.6	713-45-0.9	■	■	■				-						
1.0	2.0	0.7	713-45-1.0	■	■	■	■	□	■	723-45-1.0	■	□	■			
1.1	2.0	0.8	713-45-1.1	■	■	■				-						
1.2	2.5	0.9	713-45-1.2	■	■	■				723-45-1.2	■	■	■			
1.3	2.5	1.0	713-45-1.3	■	■	■				-						
1.4	3.0	1.1	713-45-1.4	■	■	■				-						
1.5	3.0	1.2	713-45-1.5	■	■	■	■	■	■	723-45-1.5	■	□	■			
1.8	4.0	1.5	713-45-1.8	■	■	■				723-45-1.8	■	□	■			
2.0	4.0	1.7	713-45-2.0	■	■	■				723-45-2.0	■	■	■			

■ = disponible / verfügbar / available  
 □ = selon disponibilité du stock / jenach Lagerverfügbarkeit / depending on stock availability

# TOP-LINE

Tournage arrière  
Rückwärts drehen  
Back turning

713-60° / 723-60°

L

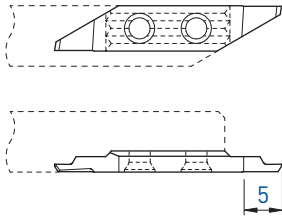

R

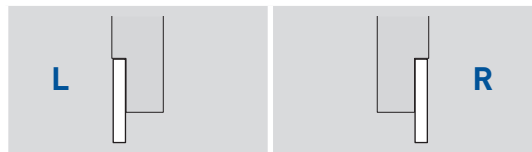
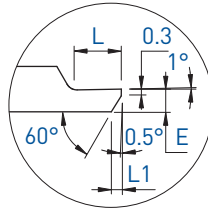
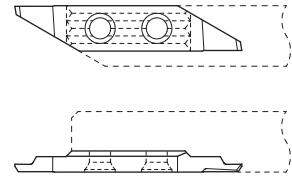

E	L	L1	Art. N°	TiAlN	TiN	N (µk20)	Art. N°	TiAlN	TiN	N (µk20)
0.8	1.6	0.3	713-60-0.8	■	■	■	723-60-0.8	■	■	■
0.9	1.6	0.35	713-60-0.9	■	■	■	-			
1.0	2.0	0.4	713-60-1.0	■	■	■	723-60-1.0	■	□	■
1.1	2.0	0.45	713-60-1.1	■	■	■	-			
1.2	2.5	0.5	713-60-1.2	■	■	■	723-60-1.2	■	□	■
1.3	2.5	0.6	713-60-1.3	■	■	■	-			
1.4	3.0	0.65	713-60-1.4	■	■	■	-			
1.5	3.0	0.7	713-60-1.5	■	■	■	723-60-1.5	■	■	■
1.8	4.0	0.9	713-60-1.8	■	■	■	723-60-1.8	■	□	■
2.0	4.0	1.0	713-60-2.0	■	■	■	723-60-2.0	■	■	■



Fonçage-tournage

Einstecken und drehen

Grooving and turning

714 / 724

L

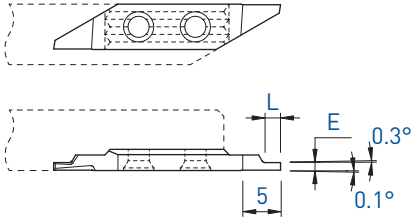

R

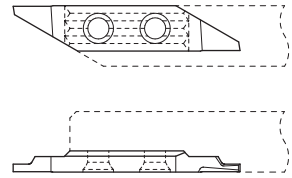

L

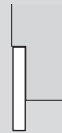

R



E	L	Art. N°	TiAlN	TiN	N (µk20)	HTA	HTiN	HN (µk10)	Art. N°	TiAlN	TiN	N (µk20)	HTA	HTiN	HN (µk10)
0.5	1.0	714-0.5	■	■	■				724-0.5	■	■	■	■	□	■
0.6	1.0	714-0.6	■	■	■				724-0.6	■	■	■			
0.7	1.5	714-0.7	■	■	■				724-0.7	■	■	■			
0.8	1.5	714-0.8	■	■	■	■	□	■	724-0.8	■	■	■			
0.9	2.0	714-0.9	■	■	■				724-0.9	■	□	■			
1.0	2.0	714-1.0	■	■	■	■	■	■	724-1.0	■	■	■			
1.1	2.0	714-1.1	■	■	■				724-1.1	■	□	■			
1.2	2.5	714-1.2	■	■	■				724-1.2	■	□	■			
1.3	2.5	714-1.3	■	■	■				724-1.3	■	■	■			
1.4	3.0	714-1.4	■	■	■				724-1.4	■	□	■			
1.5	3.0	714-1.5	■	■	■	■	■	■	724-1.5	■	■	■			

■ = disponible / verfügbar / available

□ = selon disponibilité du stock / jenach Lagerverfügbarkeit / depending on stock availability

L

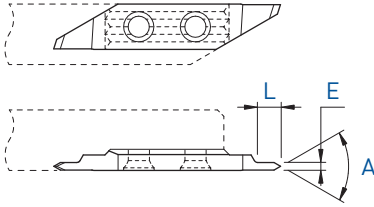

R

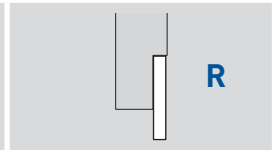
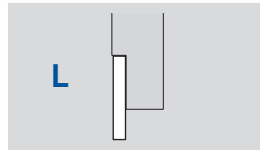
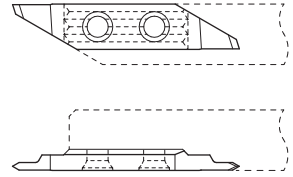

A	E	L	Art. N°	TiAlN	TiN	N (µk20)	Art. N°	TiAlN	TiN	N (µk20)
60°	1.0	3	716-60-1.0	■	■	■	726-60-1.0	■	■	■
60°	1.5	4	716-60-1.5	■	■	■	726-60-1.5	■	■	■
55°	1.0	3	716-55-1.0	■	■	■	726-55-1.0	■	□	■
55°	1.5	4	716-55-1.5	■	■	■	726-55-1.5	■	□	■

Plaquettes ébauches

WSP-Rohlinge

Blank inserts

711-EP / 721-EP

L

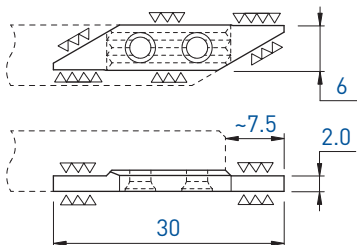

R

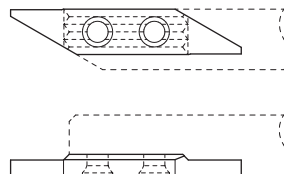

L		R			
Art. N°	TiAlN TiN N (µk20)	HTA HTiN HN (µk10)	Art. N°	TiAlN TiN N (µk20)	HTA HTiN HN (µk10)
711-EP	■ ■ ■	■ □ ■	721-EP	■ □ ■	□ □ ■

L			R			
Type		Page	Type		Page	
<b>730</b>	730	1.26	<b>740</b>	740	1.26	
	730-JET	1.27		740/730-D	1.31	
	730-NOVIBRA	1.30		740-C	1.28	
	730RC	1.29		740-JET	1.27	
<b>731</b>	731	1.32	740-NOVIBRA	1.30		
	731-E	1.67	<b>741</b>	741	1.32	
	731N	1.38/1.45		741-E	1.67	
	731R	1.39		741L	1.39	
	731RU	1.44		741LX12	1.42	
	731RX12	1.42		741LX25	1.43	
	731RX25	1.43		741LX4	1.40	
	731RX4	1.40		741LXF	1.41	
	731RXF	1.41		741N	1.38/1.45	
	731U	1.37		741U	1.37	
	731X12	1.35		741X12	1.35	
	731X25	1.36		741X25	1.36	
	731X4	1.33		741X4	1.33	
	731XF	1.34		741XF	1.34	
	<b>732</b>	732		1.46	<b>742</b>	742
732PX		1.47		742PX		1.47
732X		1.48	742X	1.48		
<b>733</b>	733	1.49	<b>743</b>	743	1.49	
	733P	1.55		743P	1.55	
	733VX-15°	1.53		743VX-15°	1.53	
	733VX-8°	1.51		743VX-8°	1.51	
	733VX-805	1.52		743VX-805	1.52	
	733X	1.50		743X	1.50	
	733ZX	1.54		743ZX10	1.54	
<b>734</b>	734	1.56	<b>744</b>	744	1.56	
	734VS	1.57		744VS	1.57	
	734X	1.58		744X	1.58	
	734ZX	1.59		744ZX	1.59	
<b>735</b>	735	1.61	744ZXT	1.60		
	735X-90	1.62	<b>745</b>	745	1.61	
<b>736</b>	736	1.63		745X-90	1.62	
	736-A60°	1.64	<b>746</b>	746	1.63	
	736-M	1.65		746-A60°	1.64	
<b>737</b>	737	1.66		746-M	1.65	
			<b>747</b>	747	1.66	

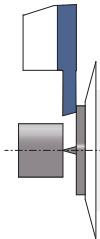
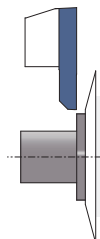
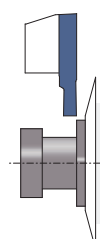
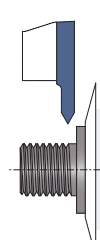
		<b>730 / 740</b> Porte-outils Halter Holders	> 1.26
	<b>731 / 741</b> Tronçonnage Abstechen Parting off		> 1.32
		<b>741L / 731R</b> Tronçonnage - coupe déportée Abstechen - versetztes Schneiden Parting off - cut off line	> 1.39
	<b>732 / 742</b> Tournage avant Vorwärts drehen Front turning		> 1.46
		<b>733 / 743</b> Tournage arrière Rückwärts drehen Back turning	> 1.49
	<b>734 / 744</b> Fonçage-tournage Einstechen und drehen Grooving and turning		> 1.56
		<b>735 / 745</b> Gorges Einstechen Grooving	> 1.61
	<b>736 / 746</b> Filetage Gewinde drehen Threading		> 1.63
		<b>737 / 747</b> Plaquettes à rayon Radius Wendeplatten Radius inserts	> 1.66
		Plaquettes ébauches WSP-Rohlinge Blank inserts	> 1.67

L

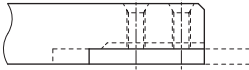
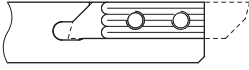

R

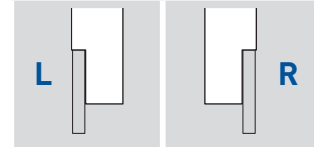
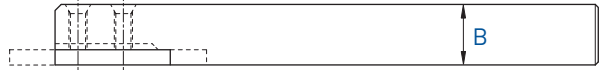
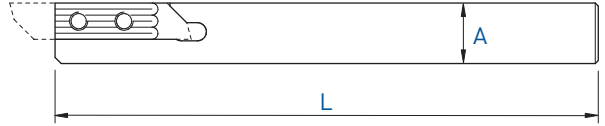

Serrage standard A  
Standard Spannsystem A  
Standard clamping system A

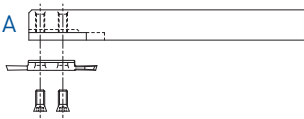

Serrage B  
Spannsystem B  
Clamping system B

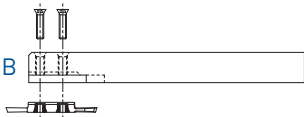

A x B	L	Serrage Spannsystem Clamping	Art. N°	Art. N°
7 x 7	115	A	730-7	740-7
8 x 8	115	A + B	730-8	740-8
8 x 8	140	A + B	730-8-140	-
10 x 10	115	A + B	730-10	740-10
10 x 10	50	A + B	730-10-50	740-10-50
12 x 12	130	A + B	730-12	740-12
12 x 12	90	A + B	730-12-90	740-12-90
12.7 x 12.7	130	A + B	730-12.7	740-12.7
16 x 16	130	A + B	730-16	740-16
16 x 16	75	A + B	730-16-75	740-16-75
20 x 20	120	A + B	730-20	740-20

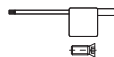

Chaque support est livré avec vis et clé.  
Jeder Halter wird mit Spannschraube(n) und Schlüssel geliefert.  
Screw(s) and key are included with each tool holder.

Porte-outils avec arrosage intégré  
 Halter mit integrierter Kühlmittelzufuhr  
 Holders with integrated coolant supply

730-JET / 740-JET

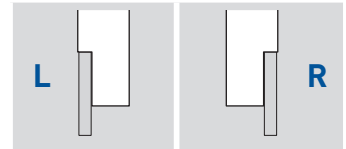
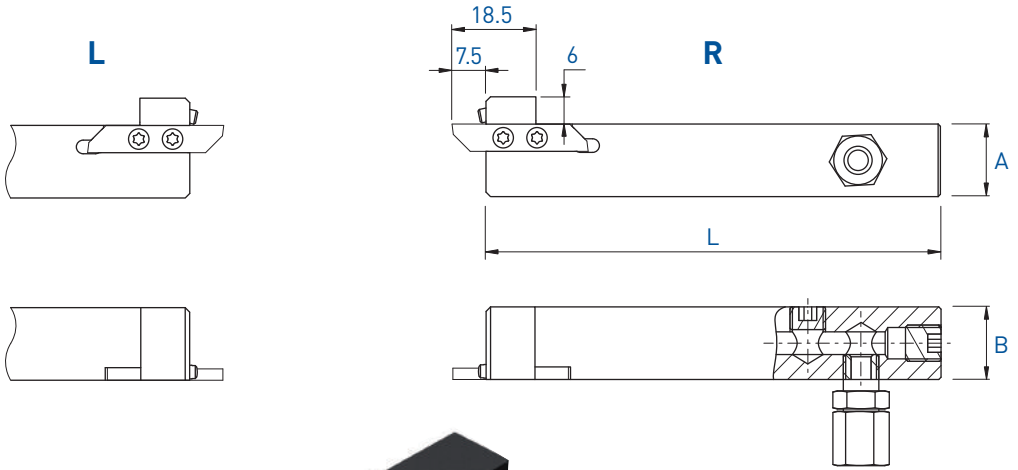

A x B	L	Serrage Spannsystem Clamping	Art. N°	Art. N°
8 x 10	100	A + B	-	740-0810-JET
10 x 12	100	A + B	730-1012-JET	740-1012-JET
10 x 12	80	A + B	-	740-1012-80-JET <b>new</b>
12 x 12	100	A + B	730-12-JET	740-12-JET
12.7 x 12.7	100	A + B	730-12.7-JET	740-12.7-JET
16 x 16	100	A + B	730-16-JET	740-16-JET
20 x 20	100	A + B	730-20-JET	740-20-JET



Chaque support est livré avec vis et clé.  
 Jeder Halter wird mit Spannschraube(n) und Schlüssel geliefert.  
 Screw(s) and key are included with each tool holder.

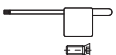

Pièces de rechange Ersatzteile Spare parts	Art. N°	Art. N°	Buse Düse Nozzle Art. N°	Option Art. N°
740-0810-JET	J-M5-D5	JB-M5	-	JC-M5-D5
730-JET / 740-JET	J-M8X1-D6	JB-M8X1	JJ-M3X6-D1.5	-

R

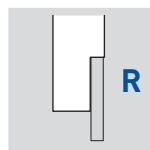
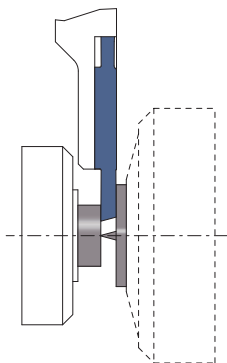
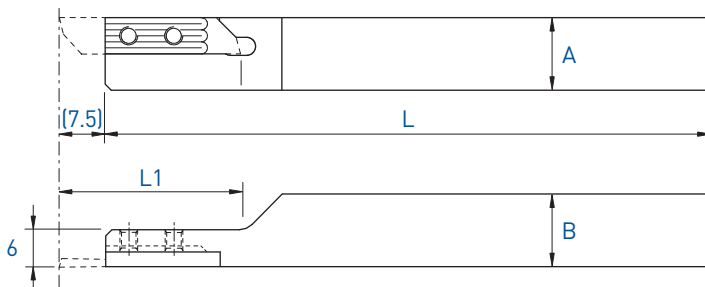

A x B	L	L1	Serrage Spannsystem Clamping	Art. N°
8 x 8	115	24	A	<b>740-C-8</b>
10 x 10	115	24	A	<b>740-C-10</b>
12 x 12	130	30	A	<b>740-C-12</b>
16 x 16	130	40	A	<b>740-C-16</b>

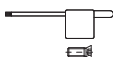

Chaque support est livré avec vis et clé.  
Jeder Halter wird mit Spannschraube(n) und Schlüssel geliefert.  
Screw(s) and key are included with each tool holder.



Porte-outils

Halter

Holders

Coupe à droite déportée

Versetztes Rechtsschneiden

Right cut off line

730RC

Utiliser des plaquettes type 731R  
WSP Typ 731R verwenden  
Use inserts type 731R

Voir pages 1.39 - 1.45  
Siehe Seiten 1.39 - 1.45  
See pages 1.39 - 1.45

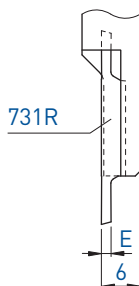
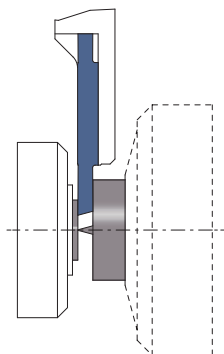
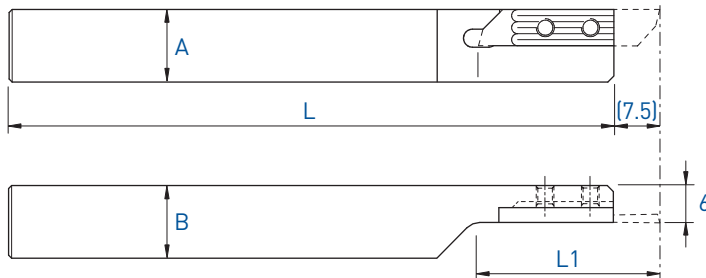

L (R)

Coupe à droite déportée  
Versetztes Rechtsschneiden  
Right cut off line



A x B	L	L1	Art. N°
8 x 8	115	24	<b>730RC-8</b>
10 x 10	115	24	<b>730RC-10</b>
12 x 12	130	30	<b>730RC-12</b>
16 x 16	130	40	<b>730RC-16</b>

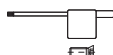

Chaque support est livré avec vis et clé.  
Jeder Halter wird mit Spannschraube(n) und Schlüssel geliefert.  
Screw(s) and key are included with each tool holder.

# TOP-LINE

Porte-outils en métal lourd anti-vibratoire  
 Schwingungsdämpfende Schwermetallhalter  
 Low vibration heavy metal holders

730-NOVIBRA  
 740-NOVIBRA

L

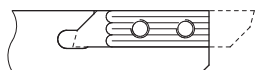

R

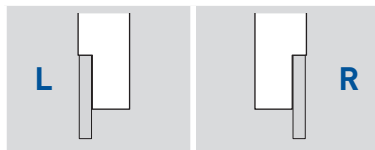
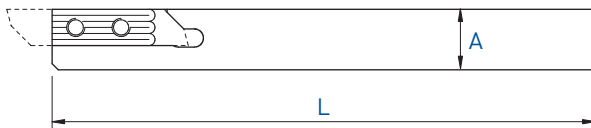

A x B	L	Serrage Spannsystem Clamping	Art. N°	Art. N°
7 x 7	115	A	730-7-NOVIBRA	740-7-NOVIBRA
8 x 8	115	A + B	730-8-NOVIBRA	740-8-NOVIBRA
8 x 8	80	A + B	-	740-8-80-NOVIBRA
10 x 10	115	A + B	-	740-10-NOVIBRA
12 x 12	130	A + B	-	740-12-NOVIBRA

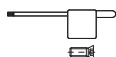

Chaque support est livré avec vis et clé.  
 Jeder Halter wird mit Spannschraube(n) und Schlüssel geliefert.  
 Screw(s) and key are included with each tool holder.

Porte-outils

Halter

Holder

740 / 730-D

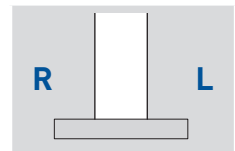
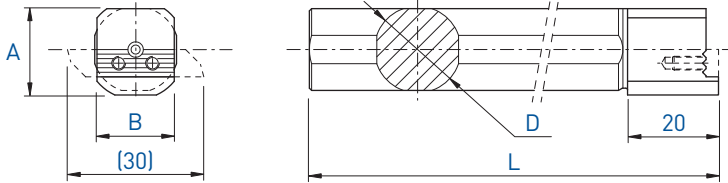

A x B	L	D	Art. N°
19 x 17	160	16	740/730-D16
19 x 17	160	19.05	740/730-D19.05
19 x 17	110	19.05	740/730-D19.05-S
19.5 x 17	160	20	740/730-D20
20 x 17	110	22	740/730-D22
22 x 17	200	25	740/730-D25
22 x 17	200	25.4	740/730-D25.4

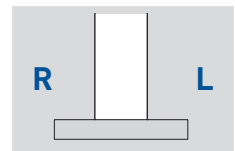
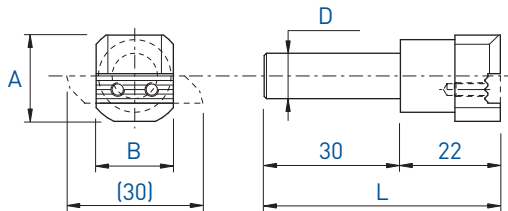

A x B	L	D	Art. N°
19 x 17	52	10	740/730-D10

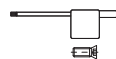

Chaque support est livré avec vis et clé.  
 Jeder Halter wird mit Spannschraube(n) und Schlüssel geliefert.  
 Screw(s) and key are included with each tool holder.

- Tronçonnage
- Abstechen
- Parting off

731 / 741

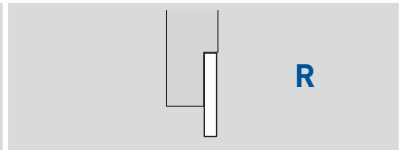
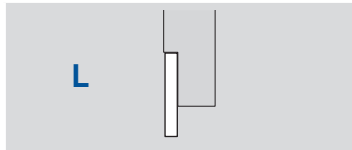
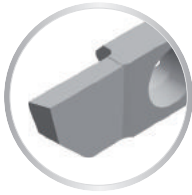
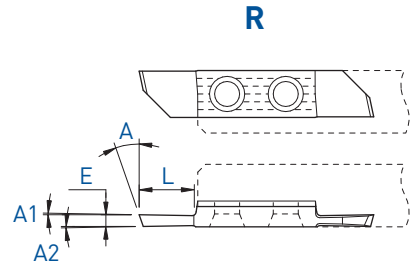
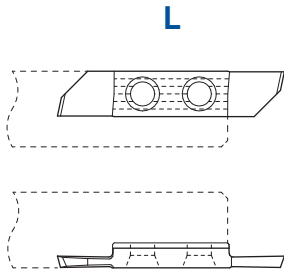

E	A	A1	A2	L	L						R							
					Art. N°	TiAlN	TiN	N (µk20)	HTA	HTiN	HN (µk10)	Art. N°	TiAlN	TiAlX	TiN	N (µk20)	HTA	HTiN
0.6	18°	2.5°	0.5°	3	731-0.6	■	■	■	■	■	■	741-0.6	■	■	■	■	■	■
0.8	20°	0.3°	0.3°	5	731-0.8	■	■	■	■	□	■	741-0.8	■	■	■	■	■	■
1.0	20°	0.3°	0.3°	5	731-1.0	■	■	■	■	■	■	741-1.0	■	■	■	■	■	■
1.2	20°	0.3°	0.3°	5	731-1.2	■	■	■	■	□	■	741-1.2	■	■	■	■	■	■
1.5	20°	0.3°	0.3°	7	731-1.5	■	■	■	■	■	■	741-1.5	■	■	■	■	■	■
1.8	20°	0.3°	0.3°	7	731-1.8	■	■	■	■	□	■	741-1.8	■	■	■	■	■	□
2.0	20°	0.3°	0.3°	7	731-2.0	■	■	■	■	□	■	741-2.0	■	■	■	■	■	■
2.5	20°	0.3°	0.3°	7	731-2.5	■	■	■	■	■	■	741-2.5	■	■	■	■	■	□

7XX-XX-B



Sur demande pour serrage type B, voir page 1.03  
 Wahlweise mit B-Spannsystem, siehe Seite 1.03  
 On request for B clamping system, see page 1.03

Tronçonnage  
Abstechen  
Parting off

731X4 / 741X4

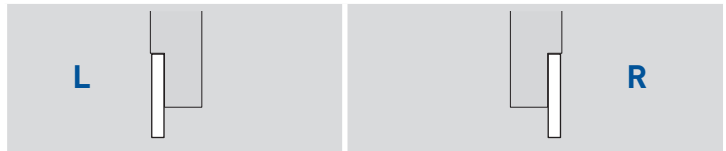
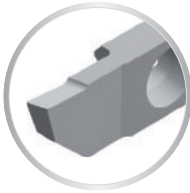
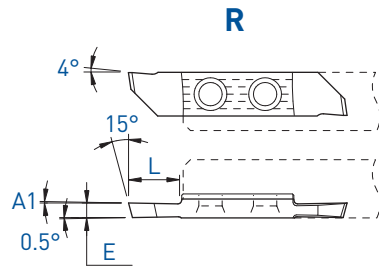
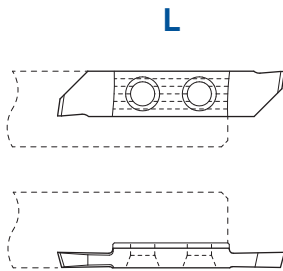

E	A1	L	Art. N°	L			R									
				TiAlN	TiN	N (µk20)	HTA	HTiN	HN (µk10)	Art. N°	TiAlN	TiAlX	TiN	N (µk20)	HTA	HTiN
0.6	2.5°	3	731X4-0.6	■	■	■	■	■	741X4-0.6	■	■	■	■	■	■	■
0.8	0.5°	4	-						741X4-0.8					■	■	
1.0	0.5°	5	731X4-1.0	■	■	■			741X4-1.0	■	■	■	■	■	□	■
1.5	0.5°	7	731X4-1.5	■	■	■	■	□	741X4-1.5	■	■	■	■	■	□	■
2.0	0.5°	7	731X4-2.0	■	■	■			741X4-2.0	■	■	■	■			

7XX-XX-B

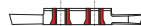

Sur demande pour serrage type B, voir page 1.03  
Wahlweise mit B-Spannsystem, siehe Seite 1.03  
On request for B clamping system, see page 1.03

■ = disponible / verfügbar / available  
□ = selon disponibilité du stock / jenach Lagerverfügbarkeit / depending on stock availability

# TOP-LINE

- Tronçonnage
- Abstechen
- Parting off

## 731XF / 741XF

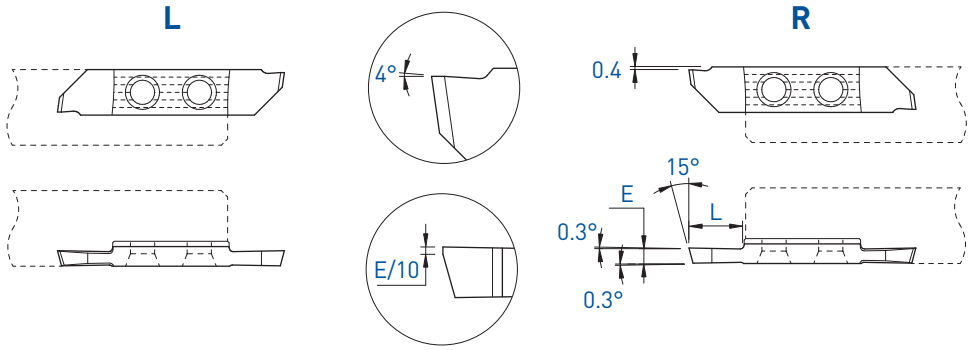

E	L	Art. N°	TiAlN			HTA			Art. N°	TiAlN			HTA		
			Ti	Al	N	HTA	HTiN	HN (µk10)		Ti	Al	N	HTA	HTiN	HN (µk10)
1.2	5	-	■	■	■	■	■	■	741XF-1.2	■	□	■	■	■	■
1.5	7	731XF-1.5	■	■	■	■	■	■	741XF-1.5	■	■	■	■	■	■
2.0	7	731XF-2.0	■	■	■	■	■	■	741XF-2.0	■	■	■	■	■	■
2.5	7	731XF-2.5	■	■	■	■	■	■	741XF-2.5	■	■	■	■	■	■

7XX-XX-B



Sur demande pour serrage type B, voir page 1.03  
 Wahlweise mit B-Spannsystem, siehe Seite 1.03  
 On request for B clamping system, see page 1.03

Tronçonnage

Abstechen

Parting off

731X12 / 741X12

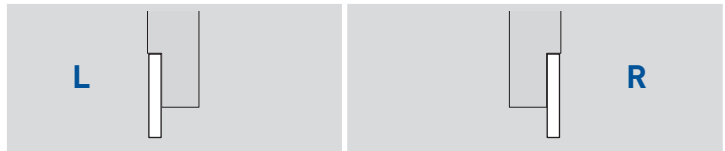
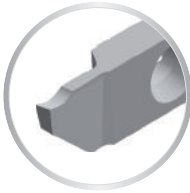
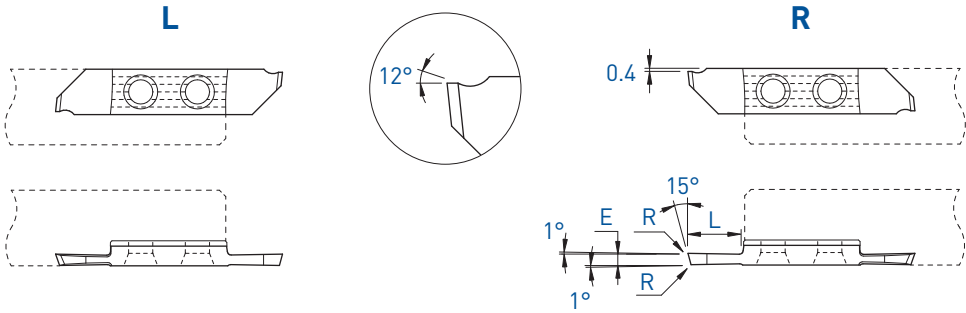

E	L	R	Art. N°	L			R			HTA	HTiN	HN (µk10)		
				TiAlN	TiN	N (µk20)	TiAlN	TiAlX	TiN				N (µk20)	
0.5	3	0.03	-									■	■	
1.0	5	0.03	731X12-1.0	■	■	■						■	□	■
1.5	7	0.03	731X12-1.5	■	■	■						■	■	■
2.0	7	0.03	731X12-2.0	■	■	■						■	□	■

7XX-XX-B

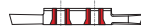

Sur demande pour serrage type B, voir page 1.03  
Wahlweise mit B-Spannsystem, siehe Seite 1.03  
On request for B clamping system, see page 1.03

■ = disponible / verfügbar / available

□ = selon disponibilité du stock / jenach Lagerverfügbarkeit / depending on stock availability

Tronçonnage  
Abstechen  
Parting off

## 731X25 / 741X25

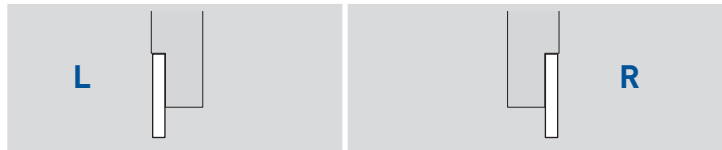
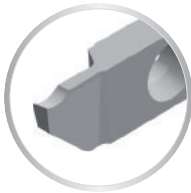
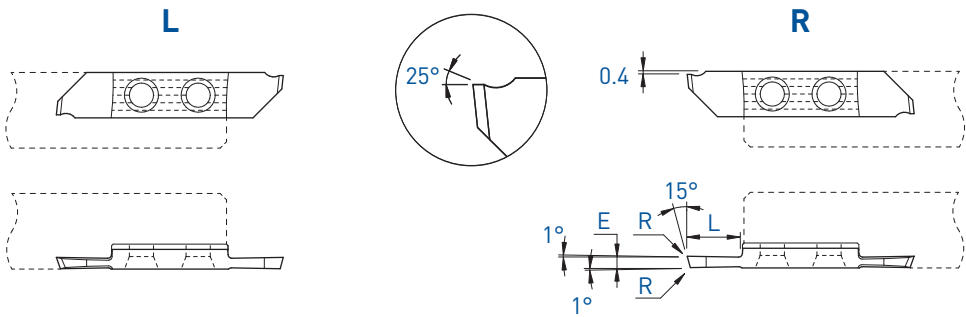

E	L	Art. N°	L			R			Art. N°	R					
			TiAlN	TiN	N (µk20)	HTA	HTiN	HN (µk10)		TiAlN	TiAlX	TiN	N (µk20)	HTA	HTiN
1.0	5	731X25-1.0	■	■	■				741X25-1.0	■	■	■	■	□	■
1.5	7	731X25-1.5	■	■	■				741X25-1.5	■	■	■	■	□	■
2.0	7	731X25-2.0	■	■	■				741X25-2.0	■	■	■	■	□	■

7XX-XX-B

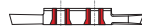

Sur demande pour serrage type B, voir page 1.03  
Wahlweise mit B-Spannsystem, siehe Seite 1.03  
On request for B clamping system, see page 1.03



Tronçonnage

Abstechen

Parting off

731U / 741U

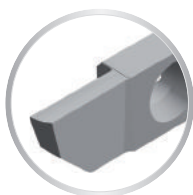
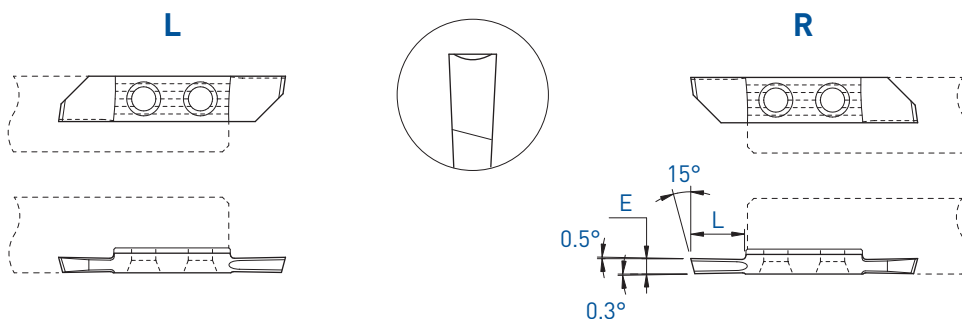

E	L	Art. N°	L			R									
			TiAlN	TiN	N (µk20)	HTA	HTiN	HN (µk10)	Art. N°	TiAlN	TiN	N (µk20)	HTA	HTiN	HN (µk10)
1.5	7	731U-1.5	■	■	■	■	□	■	741U-1.5	■	■	■	■	■	■
2.0	7	731U-2.0	■	■	■	■	□	■	741U-2.0	■	■	■	■	□	■

7XX-XX-B



Sur demande pour serrage type B, voir page 1.03  
Wahlweise mit B-Spannsystem, siehe Seite 1.03  
On request for B clamping system, see page 1.03

■ = disponible / verfügbar / available

□ = selon disponibilité du stock / jenach Lagerverfügbarkeit / depending on stock availability

Tronçonnage

Abstechen

Parting off

## 731N / 741N

L

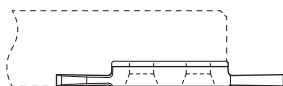
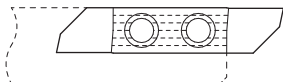

R

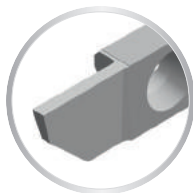
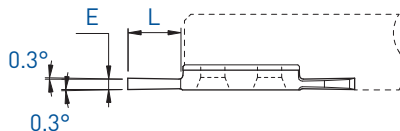
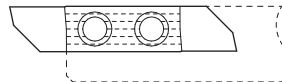

L



R



E	L	Art. N°	TiAlN	TiN	N (µk20)	HTA	HTiN	HN (µk10)	Art. N°	TiAlN	TiN	N (µk20)	HTA	HTiN	HN (µk10)
1.0	5	731N-1.0	■	■	■	■	□	■	741N-1.0	■	■	■	■	□	■
1.5	7	731N-1.5	■	■	■	■	□	■	741N-1.5	■	■	■	■	□	■

7XX-XX-B



Sur demande pour serrage type B, voir page 1.03  
Wahlweise mit B-Spannsystem, siehe Seite 1.03  
On request for B clamping system, see page 1.03

Tronçonnage  
Abstechen  
Parting off

Coupe déportée  
Versetztes Schneiden  
Cut off line

741L / 731R

Cut L

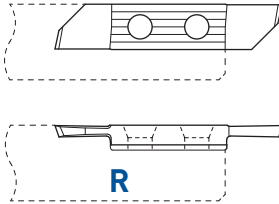

Cut R

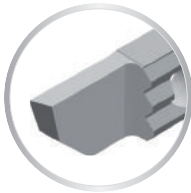
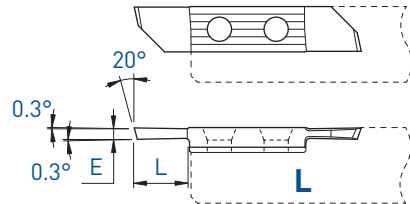

R (L)

Coupe à gauche déportée  
Versetztes Linksschneiden  
Left cut off line

L (R)

Coupe à droite déportée  
Versetztes Rechtsschneiden  
Right cut off line

E	L	Art. N°	TiAlN	TiN	N (µk20)	HTA	HTiN	HN (µk10)	Art. N°	TiAlN	TiN	N (µk20)	HTA	HTiN	HN (µk10)
1.0	5	741L-1.0	■	■	■	■	□	■	731R-1.0	■	■	■	■	■	■
1.2	5	741L-1.2	■	■	■	■	□	■	731R-1.2	■	■	■	■	□	■
1.5	7	741L-1.5	■	■	■	■	■	■	731R-1.5	■	■	■	■	■	■
2.0	7	741L-2.0	■	■	■	■	□	■	731R-2.0	■	■	■	■	□	■
2.5	7	741L-2.5	■	■	■				731R-2.5	■	■	■			

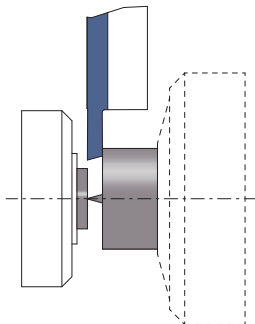

Tronçonnage  
Abstechen  
Parting off

Coupe déportée  
Versetztes Schneiden  
Cut off line

741LX4 / 731RX4

Cut L

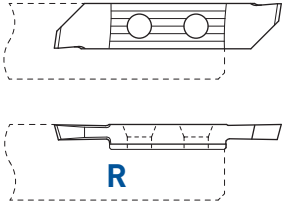

Cut R

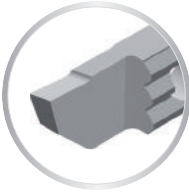
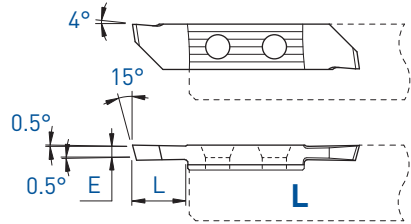

R (L)

Coupe à gauche déportée  
Versetztes Linksschneiden  
Left cut off line

L (R)

Coupe à droite déportée  
Versetztes Rechtsschneiden  
Right cut off line

E	L	Art. N°	TiAlN	TiN	N (µk20)	HTA	HTiN	HN (µk10)	Art. N°	TiAlN	TiN	N (µk20)	HTA	HTiN	HN (µk10)
1.5	5	741LX4-1.5	■	■	■				731RX4-1.5	■	■	■	■	■	■

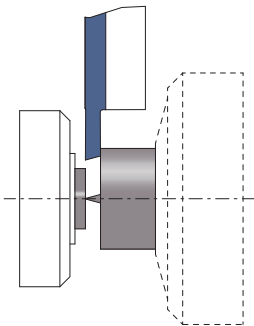

Tronçonnage  
Abstechen  
Parting off

Coupe déportée  
Versetztes Schneiden  
Cut off line

741LXF / 731RXF

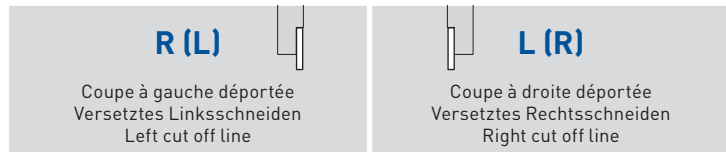
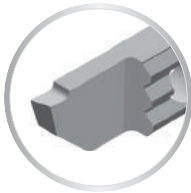
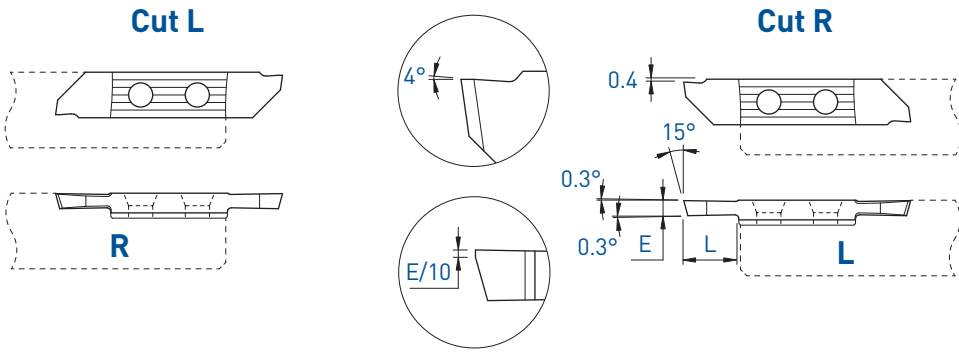

E	L	Art. N°	R (L)			L (R)		
			TiAlN	TiN	N (µk20)	HTA	HTiN	HN (µk10)
1.5	7	741LXF-1.5	■	■	■			
2.0	7	741LXF-2.0	■	■	■			
2.5	7	741LXF-2.5	■	■	■			

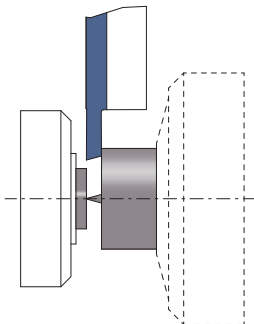

■ = disponible / verfügbar / available  
□ = selon disponibilité du stock / jenach Lagerverfügbarkeit / depending on stock availability

Tronçonnage  
Abstechen  
Parting off

Coupe déportée  
Versetztes Schneiden  
Cut off line

## 741LX12 / 731RX12

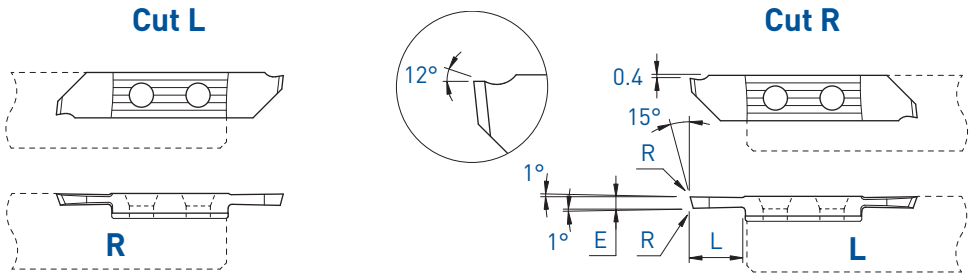

### R (L)

Coupe à gauche déportée  
Versetztes Linksschneiden  
Left cut off line

### L (R)

Coupe à droite déportée  
Versetztes Rechtsschneiden  
Right cut off line

E	L	R	Art. N°	TiAlN	TiN	N (µk20)	HTA	HTiN	HN (µk10)	Art. N°	TiAlN	TiN	N (µk20)	HTA	HTiN	HN (µk10)
1.0	5	0.03	-							731RX12-1.0	■	□	■			
1.5	7	0.03	741LX12-1.5	■	■	■				731RX12-1.5	■	■	■	■	■	■

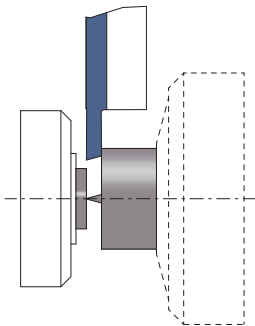

Tronçonnage  
Abstechen  
Parting off

Coupe déportée  
Versetztes Schneiden  
Cut off line

741LX25 / 731RX25

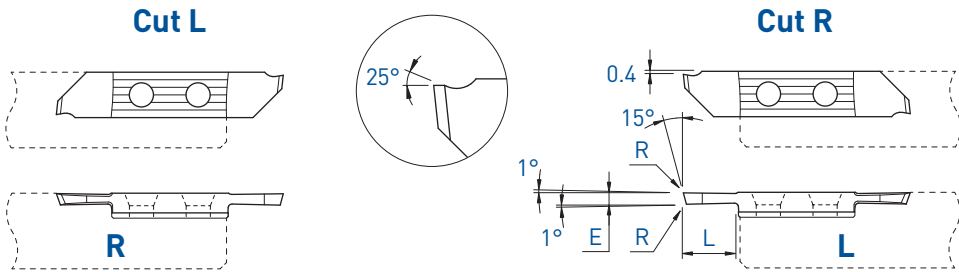

R (L)	L (R)
Coupe à gauche déportée Versetztes Linksschneiden Left cut off line	Coupe à droite déportée Versetztes Rechtsschneiden Right cut off line

E	L	R	Art. N°	TiAlN	TiN	N (µk20)	Art. N°	TiAlN	TiN	N (µk20)
1.5	7	0.03	741LX25-1.5	■	■	■	731RX25-1.5	■	■	■

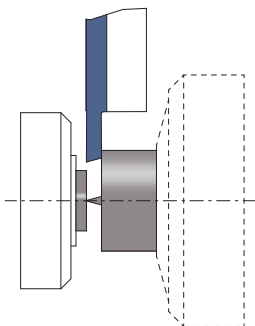

Tronçonnage

Abstechen

Parting off

Coupe déportée

Versetztes Schneiden

Cut off line

## 731RU

### Cut R

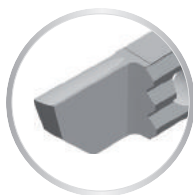
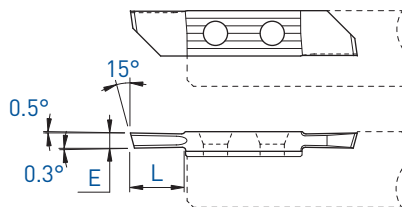
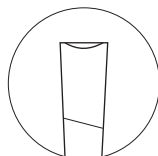

### L (R)

Coupe à droite déportée  
Versetztes Rechtsschneiden  
Right cut off line

E	L	Art. N°	TiAlN	TiN	N (µk20)	HTA	HTiN	HN (µk10)
1.0	5	731RU-1.0	■	□	■			
1.2	5	731RU-1.2	■	□	■			
1.5	7	731RU-1.5	■	□	■	■	□	■
2.0	7	731RU-2.0	■	□	■			

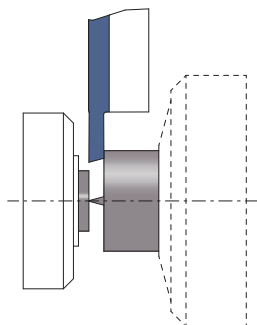



Tronçonnage  
Abstechen  
Parting off

Coupe déportée  
Versetztes Schneiden  
Cut off line

741N / 731N

Cut L

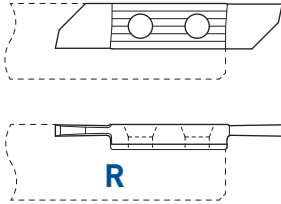

Cut R

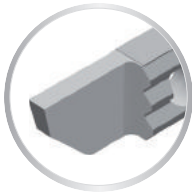
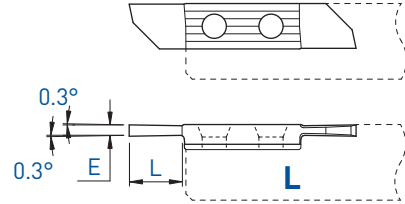

R (L)

Coupe à gauche déportée  
Versetztes Linksschneiden  
Left cut off line

L (R)

Coupe à droite déportée  
Versetztes Rechtsschneiden  
Right cut off line

E	L	Art. N°	TiAlN	TiN	N (µk20)	HTA	HTiN	HN (µk10)	Art. N°	TiAlN	TiN	N (µk20)	HTA	HTiN	HN (µk10)
1.0	5	741N-1.0	■	■	■	■	□	■	731N-1.0	■	■	■	■	□	■
1.5	7	741N-1.5	■	■	■	■	□	■	731N-1.5	■	■	■	■	□	■

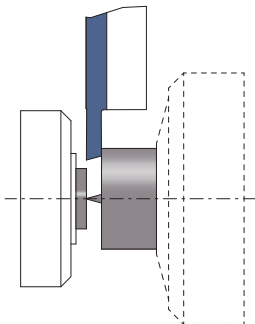

# TOP-LINE

Tournage avant  
Vorwärts drehen  
Front turning

732 / 742

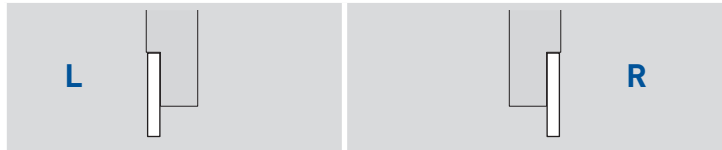
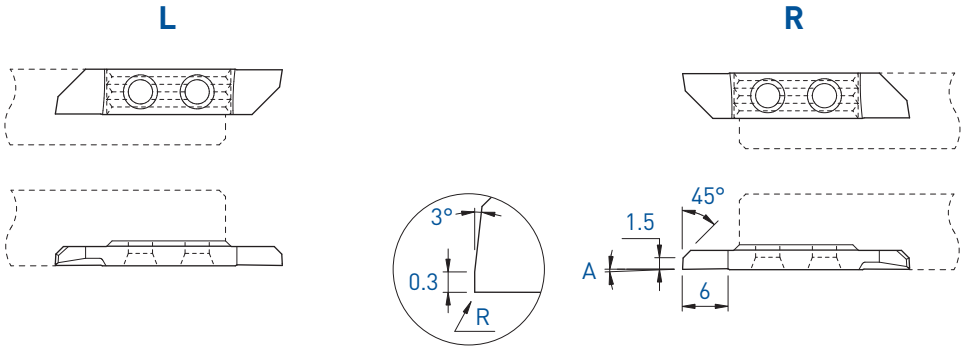

A	R	Art. N°	TiAlN	TiN	N (µk20)	HTA	HTiN	HN (µk10)	Art. N°	TiAlN	TiAlX	TiN	N (µk20)	HTA	HTiN	HN (µk10)
0°	0	732	■	■	■	■	■	■	742	■	■	■	■	■	■	■
2°	0	732-2°	■	■	■	■	□	■	742-2°	■	■	■	■	■	■	■

7XX-XX-B

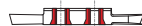

Sur demande pour serrage type B, voir page 1.03  
Wahlweise mit B-Spannsystem, siehe Seite 1.03  
On request for B clamping system, see page 1.03

Tournage avant  
Vorwärts drehen  
Front turning

732PX / 742PX

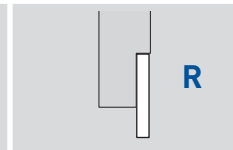
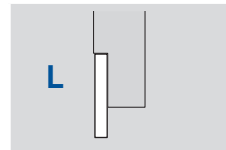
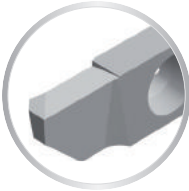
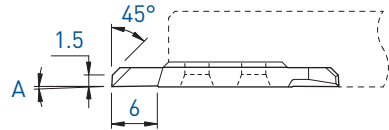
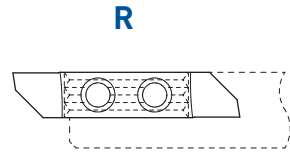
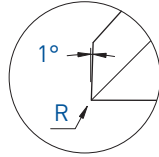
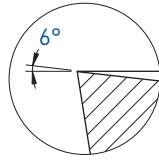
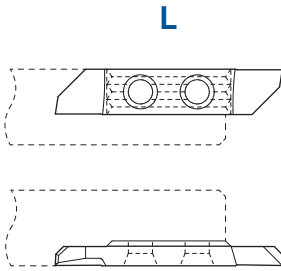

A	R	Art. N°	TiAlN	TiN	N [µk20]	Art. N°	TiAlN	TiN	N [µk20]
0°	0	732PX	■	■	■	742PX	■	■	■

7XX-XX-B

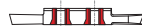

Sur demande pour serrage type B, voir page 1.03  
Wahlweise mit B-Spannsystem, siehe Seite 1.03  
On request for B clamping system, see page 1.03

■ = disponible / verfügbar / available  
□ = selon disponibilité du stock / jenach Lagerverfügbarkeit / depending on stock availability

# TOP-LINE

Tournage avant  
Vorwärts drehen  
Front turning

## 732X / 742X

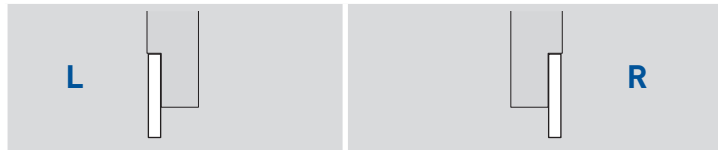
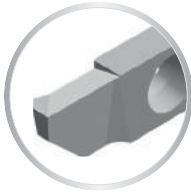
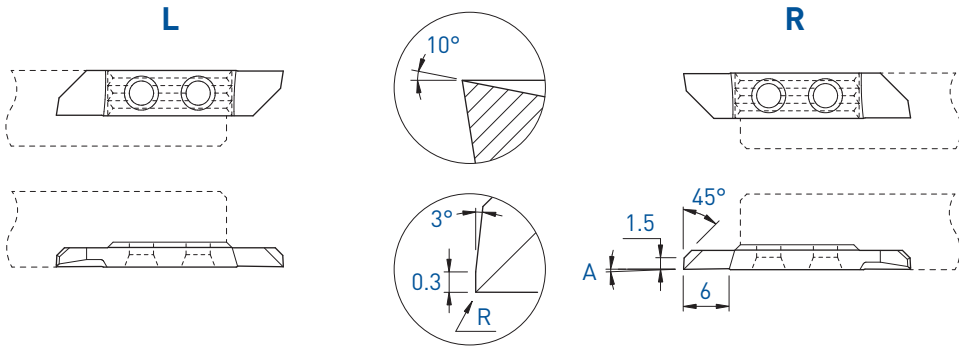

A	R	Art. N°	TiAlN	TiN	N (µk20)	HTA	HTiN	HN (µk10)	Art. N°	TiAlN	TiAlX	TiN	N (µk20)	HTA	HTiN	HN (µk10)
0°	0	732X	■	■	■	■	■	■	742X	■	■	■	■	■	■	■

7XX-XX-B



Sur demande pour serrage type B, voir page 1.03  
Wahlweise mit B-Spannsystem, siehe Seite 1.03  
On request for B clamping system, see page 1.03

Tournage arrière  
 Rückwärts drehen  
 Back turning

733 / 743

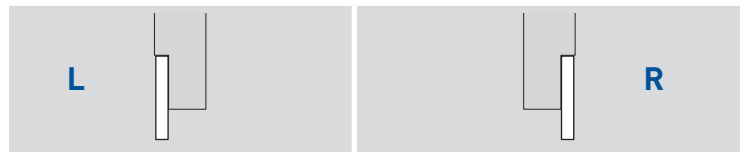
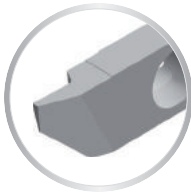
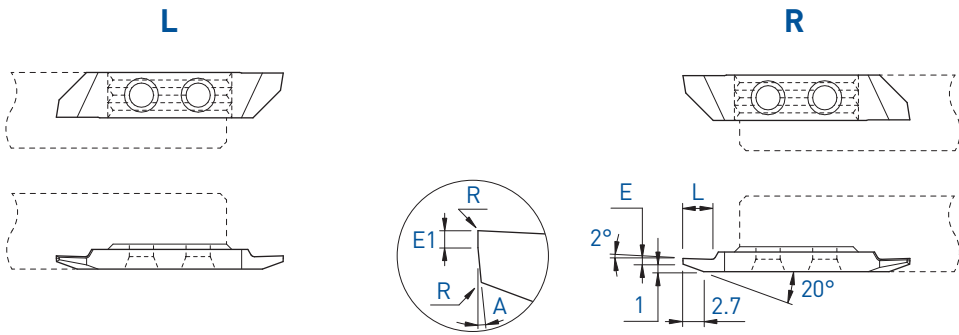

E	E1	A	L	R	Art. N°	TiAlN	TiN	N (µk20)	HTA	HTiN	HN (µk10)	Art. N°	TiAlN	TiAlX	TiN	N (µk20)	HTA	HTiN	HN (µk10)
0.5	0.25	3°	3	0	733-0.5	■	■	■	■	□	■	743-0.5	■	■	■	■	■	■	■
0.5	-	2°	3	0.08	733-0.5-R08	■	■	■	■	□	■	743-0.5-R08	■	■	■	■	■	□	■
0.8	0.30	3°	4	0	733-0.8	■	■	■	■	□	■	743-0.8	■	■	■	■	■	□	■
1.0	0.40	3°	4	0	733-1.0	■	■	■	■	□	■	743-1.0	■	■	■	■	■	□	■
1.2	0.50	3°	5	0	733-1.2	■	■	■	■	□	■	743-1.2	■	■	■	■	■	□	■
1.5	0.50	3°	6	0	733-1.5	■	■	■	■	□	■	743-1.5	■	■	■	■	■	□	■

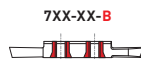

7XX-XX-B Sur demande pour serrage type B, voir page 1.03  
 Wahlweise mit B-Spannsystem, siehe Seite 1.03  
 On request for B clamping system, see page 1.03

■ = disponible / verfügbar / available  
 □ = selon disponibilité du stock / jenach Lagerverfügbarkeit / depending on stock availability

# TOP-LINE

Tournage arrière  
Rückwärts drehen  
Back turning

## 733X / 743X

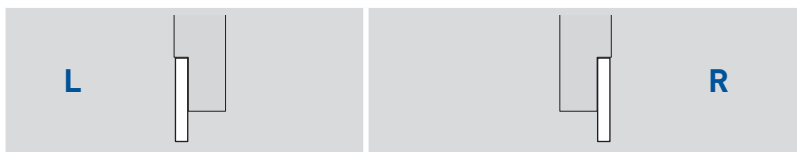
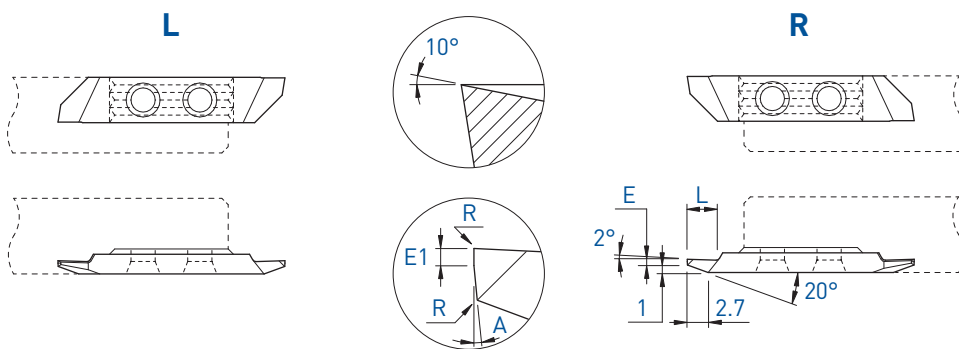

E	E1	A	L	R	Art. N°	TiAlN	TiN	N (µk20)	HTA	HTiN	HN (µk10)	Art. N°	TiAlN	TiAlX	TiN	N (µk20)	HTA	HTAX <small>new</small>	HTiN	HN (µk10)
0.5	0.25	3°	3	0	733X-0.5	■	■	■	■	□	■	743X-0.5	■	■	■	■	■	□	□	■
0.5	-	2°	3	0.08	733X-0.5-R08	■	■	■				743X-0.5-R08	■	■	■	■	■	□	□	■
0.8	0.30	3°	4	0	733X-0.8	■	■	■				743X-0.8	■		■	■			□	■
1.0	0.40	3°	4	0	733X-1.0	■	■	■				743X-1.0	■		■	■			□	■
1.2	0.50	3°	5	0	733X-1.2	■	■	■				743X-1.2	■		■	■			□	■
1.5	0.50	3°	6	0	733X-1.5	■	■	■				743X-1.5	■		■	■			□	■

7XX-XX-B



Sur demande pour serrage type B, voir page 1.03  
Wahlweise mit B-Spannsystem, siehe Seite 1.03  
On request for B clamping system, see page 1.03

Tournage arrière  
Rückwärts drehen  
Back turning

733VX-8° / 743VX-8°

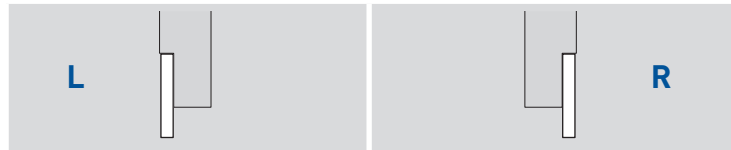
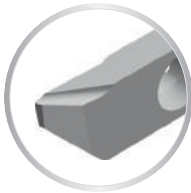
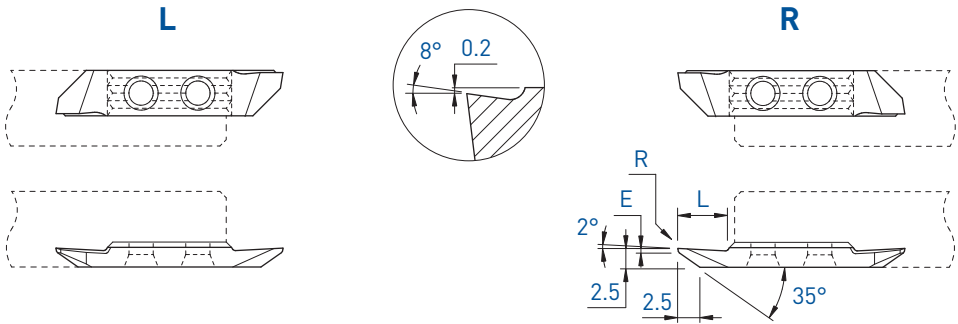

E	L	R	Art. N°	TiAlN	TiN	N (µk20)	HTA	HTiN	HN (µk10)	Art. N°	TiAlN	TiN	N (µk20)	HTA	HTiN	HN (µk10)
1.0	6.5	0	733VX-8°	■	■	■	■	■	■	743VX-8°	■	■	■	■	■	■
1.0	6.5	0.08	733VX-8°-R08	■	■	■	■	□	■	743VX-8°-R08	■	■	■	■	□	■

7XX-XX-B



Sur demande pour serrage type B, voir page 1.03  
Wahlweise mit B-Spannsystem, siehe Seite 1.03  
On request for B clamping system, see page 1.03

■ = disponible / verfügbar / available  
□ = selon disponibilité du stock / jenach Lagerverfügbarkeit / depending the stock availability

**Tournage arrière**  
**Rückwärts drehen**  
**Back turning**

**733VX-805 / 743VX-805**

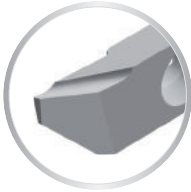
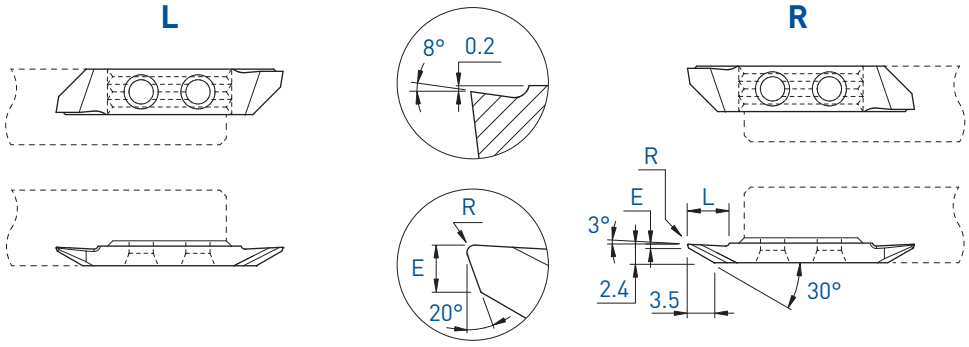

E	L	R	Art. N°	TiAlN	TiN	N (µk20)	HTA	HTiN	HN (µk10)	Art. N°	TiAlN	TiN	N (µk20)	HTA	HTiN	HN (µk10)
0.5	6	0.08	733VX-805-R08	■	□	■	■	□	■	743VX-805-R08	■	■	■	■	□	■

**7XX-XX-B**



Sur demande pour serrage type B, voir page 1.03  
 Wahlweise mit B-Spannsystem, siehe Seite 1.03  
 On request for B clamping system, see page 1.03



Tournage arrière  
 Rückwärts drehen  
 Back turning

733VX-15° / 743VX-15°

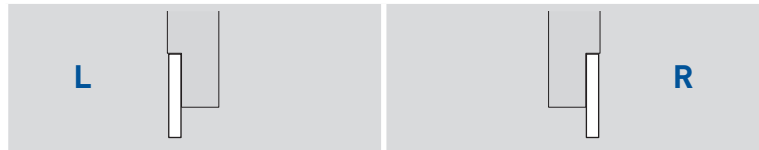
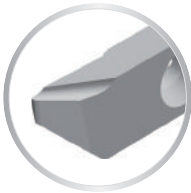
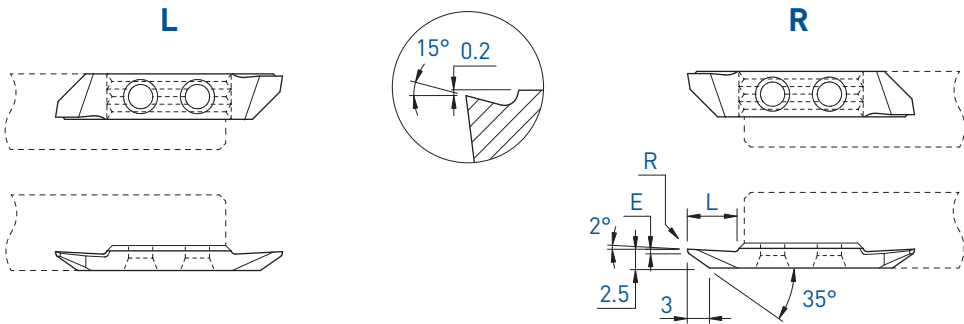

E	L	R	Art. N°	TiAlN	TiN	N (µk20)	HTA	HTiN	HN (µk10)	Art. N°	TiAlN	TiN	N (µk20)	HTA	HTiN	HN (µk10)
0.5	6.5	0	733VX-15°	■	■	■	■	□	■	743VX-15°	■	■	■	■	□	■
0.5	6.5	0.08	733VX-15°-R08	■	■	■				743VX-15°-R08	■	■	■	■	□	■

7XX-XX-B



Sur demande pour serrage type B, voir page 1.03  
 Wahlweise mit B-Spannsystem, siehe Seite 1.03  
 On request for B clamping system, see page 1.03

■ = disponible / verfügbar / available  
 □ = selon disponibilité du stock / jenach Lagerverfügbarkeit / depending on stock availability

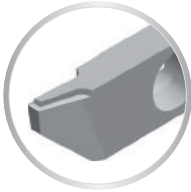
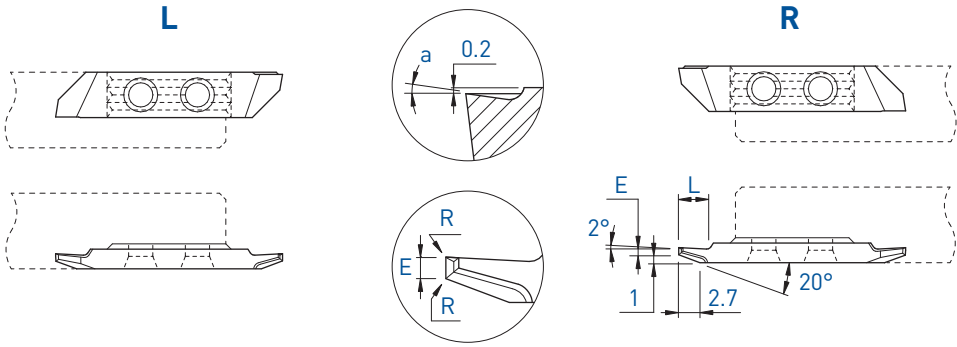

Pour un meilleur contrôle des copeaux  
Für eine bessere Spankontrolle  
For a better chip-control

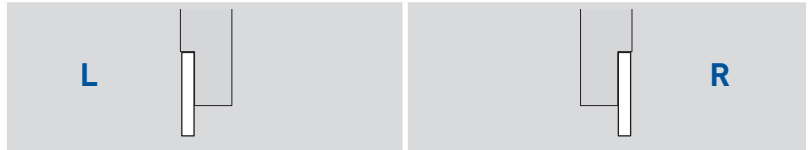

a	E	L	R	L						R						
				Art. N°	TiAlN	TiN	N (µk20)	HTA	HTiN	HN (µk10)	Art. N°	TiAlN	TiN	N (µk20)	HTA	HTiN
10°	1.0	4	0.01	733ZX10-1.0	■	□						743ZX10-1.0	■	□	■	□
	1.0	4	0.08	733ZX10-1.0-R08	■	□						743ZX10-1.0-R08	■	□	■	□

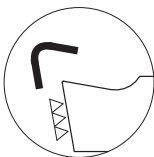

Arête de coupe honée  
Gehonte Schneidkante  
Honed edge

f min: 0.02 mm/U



7XX-XX-B

Sur demande pour serrage type B, voir page 1.03  
Wahlweise mit B-Spannsystem, siehe Seite 1.03  
On request for B clamping system, see page 1.03

Tournage arrière / pré-coupe  
 Rückwärts drehen / vorstechen  
 Back turning / pre-parting off

733P / 743P

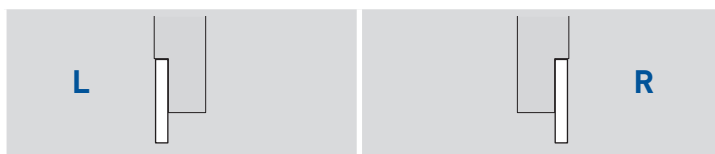
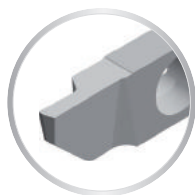
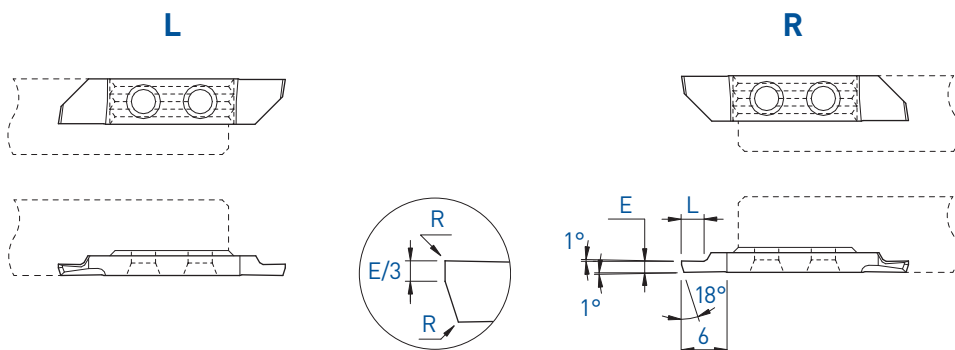

E	L	R	Art. N°	L			R											
				TiAlN	TiN	N (µk20)	HTA	HTiN	HN (µk10)	Art. N°	TiAlN	TiN	N (µk20)	HTA	HTiN	HN (µk10)		
0.8	2	0	733P-0.8	■	■	■						743P-0.8	■	■	■	■	□	■
1.0	2	0	733P-1.0	■	■	■						743P-1.0	■	■	■			
1.2	2.5	0	733P-1.2	■	■	■						743P-1.2	■	■	■			
1.5	3	0	733P-1.5	■	■	■						743P-1.5	■	■	■			

7XX-XX-B



Sur demande pour serrage type B, voir page 1.03  
 Wahlweise mit B-Spannsystem, siehe Seite 1.03  
 On request for B clamping system, see page 1.03

■ = disponible / verfügbar / available  
 □ = selon disponibilité du stock / jenach Lagerverfügbarkeit / depending on stock availability

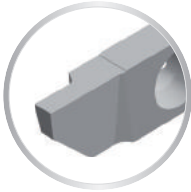
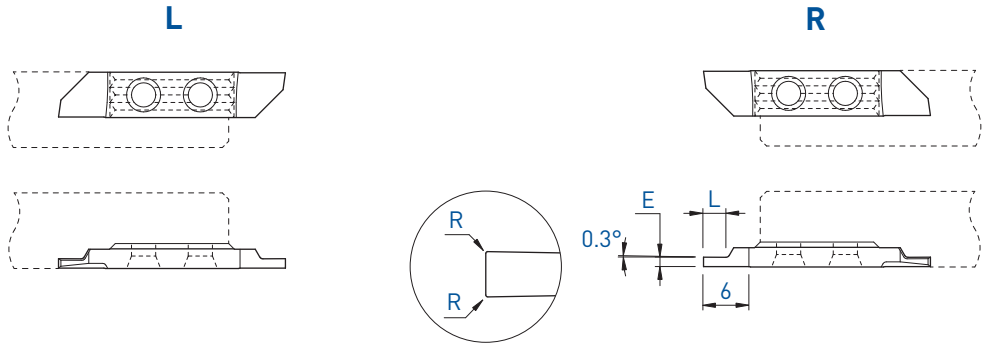

E	L	R	Art. N°	TiAlN	TiN	N (µk20)	HTA	HTiN	HN (µk10)	Art. N°	TiAlN	TiAlX	TiN	N (µk20)	HTA	HTAX	HTiN	HN (µk10)
0.5	1.5	0	734-0.5	■	■	■	■	□	■	744-0.5	■	■	■	■	■	■	■	■
0.6	1.8	0	734-0.6	■	■	■	■	□	■	744-0.6	■	■	■	■	■	■	□	■
0.75	2	0	734-0.75	■	■	■	■	■	■	744-0.75	■	■	■	■	■	■	■	■
0.8	2	0	734-0.8	■	■	■	■	□	■	744-0.8	■	■	■	■	■	■	□	■
0.8	2	0.08	-							744-0.8-R08	■	■	■	■	■	■	□	■
0.9	2.5	0	-							744-0.9	■	■	■	■	■	■	□	■
0.95	3	0	734-0.95	■	■	■	■	■	■	744-0.95	■	■	■	■	■	■	□	■
1.0	2.5	0	734-1.0	■	■	■	■	■	■	744-1.0	■	■	■	■	■	■	■	■
1.0	2.5	0.08	734-1.0-R08	■	■	■	■	■	■	744-1.0-R08	■	■	■	■	■	■	□	■
1.2	3	0	734-1.2	■	■	■	■	□	■	744-1.2	■	■	■	■	■	■	■	■
1.5	3	0	734-1.5	■	■	■	■	■	■	744-1.5	■	■	■	■	■	■	■	■
1.5	3	0.08	734-1.5-R08	■	■	■	■	□	■	744-1.5-R08	■	■	■	■	■	■	□	■
1.5	3	0.15	-							744-1.5-R15	■	■	□	■	■	■	□	■
1.5	3	0.20	-							744-1.5-R20	■	■	■	■	■	■	□	■
1.8	4	0	734-1.8	■	■	■	■	□	■	744-1.8	■	■	■	■	■	■	□	■
2.0	4	0	734-2.0	■	■	■	■	□	■	744-2.0	■	■	■	■	■	■	□	■
2.0	4	0.08	734-2.0-R08	■	■	■	■	□	■	744-2.0-R08	■	■	■	■	■	■	□	■
2.0	4	0.15	-							744-2.0-R15	■	■	□	■	■	■	□	■
2.0	4	0.20	-							744-2.0-R20	■	■	■	■	■	■	□	■
2.5	6	0	734-2.5	■	■	■	■	■	■	744-2.5	■	■	■	■	■	■	□	■

7XX-XX-B



Sur demande pour serrage type B, voir page 1.03  
Wahlweise mit B-Spannsystem, siehe Seite 1.03  
On request for B clamping system, see page 1.03

Fonçage-tournage

Einstecken und drehen

Grooving and turning

734VS / 744VS

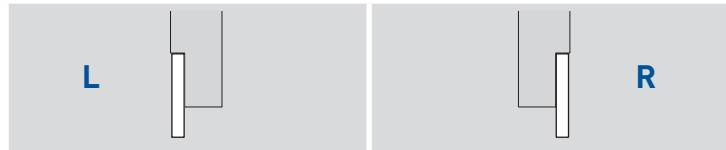
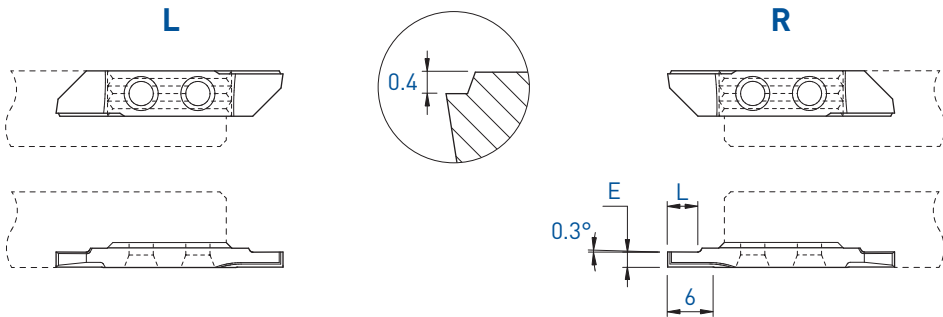

E	L	Art. N°	L			R			Art. N°	R					
			TiAlN	TiN	N (µk20)	HTA	HTiN	HN (µk10)		TiAlN	TiN	N (µk20)	HTA	HTiN	HN (µk10)
1.0	2	734VS-1.0	■	■	■	■	□	■	744VS-1.0	■	■	■	■	□	■
1.2	2.5	734VS-1.2	■	■	■	■	□	■	744VS-1.2	■	■	■	■	□	■
1.5	3	734VS-1.5	■	■	■	■	□	■	744VS-1.5	■	■	■	■	□	■
1.8	4	734VS-1.8	■	■	■				744VS-1.8	■	■	■			
2.0	4	734VS-2.0	■	■	■				744VS-2.0	■	■	■	■	□	■
2.5	6	734VS-2.5	■	■	■				744VS-2.5	■	■	■			

7XX-XX-B



Sur demande pour serrage type B, voir page 1.03  
Wahlweise mit B-Spannsystem, siehe Seite 1.03  
On request for B clamping system, see page 1.03

■ = disponible / verfügbar / available  
□ = selon disponibilité du stock / jenach Lagerverfügbarkeit / depending on stock availability

# TOP-LINE

Fonçage-tournage  
Einstecken und drehen  
Grooving and turning

## 734X / 744X

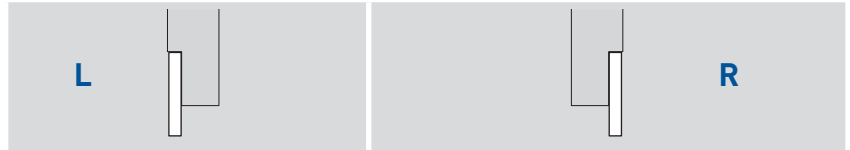
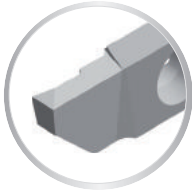
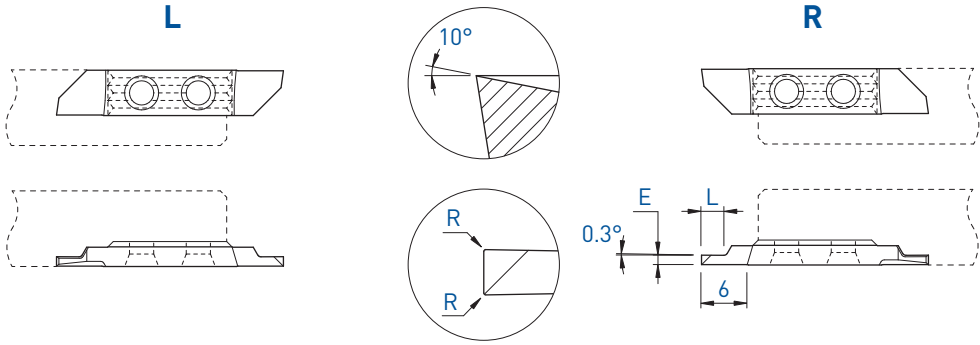

E	L	R	Art. N°	L			R			Art. N°	L			R				
				TiAlN	TiN	N (µk20)	HTA	HTIN	HN (µk10)		TiAlN	TiAlX	LoX	TiN	N (µk20)	HTA	HTAX	HTIN
0.8	2	0	734X-0.8	■	■	■	■	□	■	744X-0.8	■	■	■	■	■	■	■	■
1.0	2.5	0	734X-1.0	■	■	■	■	□	■	744X-1.0	■	■	■	■	■	■	■	■
1.0	2.5	0.08	734X-1.0-R08	■	■	■	■	□	■	744X-1.0-R08	■	■	■	■	■	■	□	■
1.2	3	0	734X-1.2	■	■	■	■	□	■	744X-1.2	■	■	■	■	■	■	□	■
1.5	3	0	734X-1.5	■	■	■	■	■	■	744X-1.5	■	■	■	■	■	■	■	■
1.5	3	0.08	734X-1.5-R08	■	■	■	■	□	■	744X-1.5-R08	■	■	■	■	■	■	□	■
1.5	3	0.15	-							744X-1.5-R15	■	■	□	■	■	■	□	■
1.5	3	0.20	-							744X-1.5-R20	■	■	■	■	■	■	□	■
1.8	4	0	734X-1.8	■	■	■				744X-1.8	■	■	■	■	■	■	□	■
2.0	4	0	734X-2.0	■	■	■	■	□	■	744X-2.0	■	■	■	■	■	■	■	■
2.0	4	0.08	734X-2.0-R08	■	■	■	■	□	■	744X-2.0-R08	■	■	■	■	■	■	■	■
2.0	4	0.15	-							744X-2.0-R15	■	■	□	■	■	■	□	■
2.0	4	0.20	734X-2.0-R20	■	■	■	■	□	■	744X-2.0-R20	■	■	■	■	■	■	□	■
2.5	6	0	734X-2.5	■	■	■	■	□	■	744X-2.5	■	■	■	■	■	■	□	■

7XX-XX-B



Sur demande pour serrage type B, voir page 1.03  
Wahlweise mit B-Spannsystem, siehe Seite 1.03  
On request for B clamping system, see page 1.03

Fonçage-tournage

Einstecken und drehen

Grooving and turning

734ZX / 744ZX

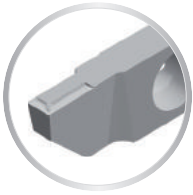
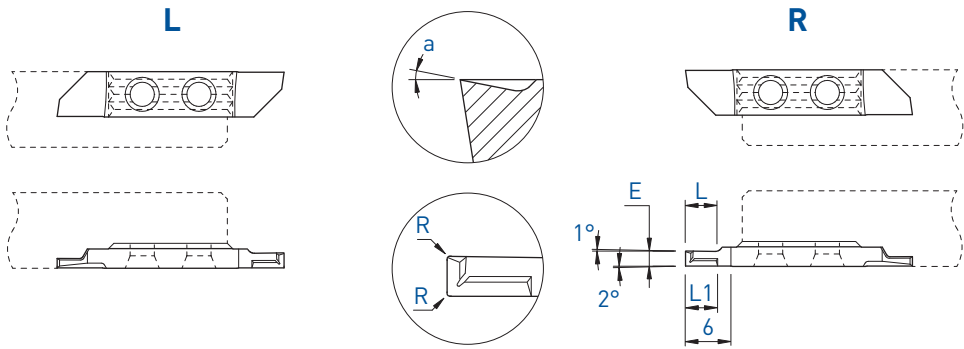

Pour un meilleur contrôle des copeaux  
Für eine bessere Spankontrolle  
For a better chip-control



a	E	L	L1	R	Art. N°	TiAlN				Art. N°	TiAlN					
						TiN	TiN	N (µk20)	HTA		HAS	HTiN	HN (µk10)	TiAlX	TiN	N (µk20)
10°	1.0	2.5	3	0.01	734ZX10-1.0	■	■			744ZX10-1.0	■	■	■	■		□
	1.5	4	4	0.01	734ZX10-1.5	■	■			744ZX10-1.5	■	■	□	■		■
	1.5	4	4	0.08	734ZX10-1.5-R08	■	■			744ZX10-1.5-R08	■	■	■	■		
	2.0	4	4	0.01	734ZX10-2.0	■	■			744ZX10-2.0	■	■	□	■		□
	2.0	4	4	0.08	734ZX10-2.0-R08	■	■			744ZX10-2.0-R08	■	■	□	■		
	2.5	6	4	0.01	734ZX10-2.5	■	■			744ZX10-2.5	■	■	□	■		□
	2.5	6	4	0.08	-					744ZX10-2.5-R08	■	■	□	■		
17°	1.0	2.5	3	0.01	-					744ZX17-1.0				■	■	



Arête de coupe honée  
Gehonte Schneidkante  
Honed edge

f min: 0.02 mm/U



7XX-XX-B

Sur demande pour serrage type B, voir page 1.03  
Wahlweise mit B-Spannsystem, siehe Seite 1.03  
On request for B clamping system, see page 1.03

■ = disponible / verfügbar / available  
□ = selon disponibilité du stock / jenach Lagerverfügbarkeit / depending on stock availability

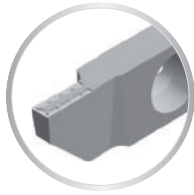
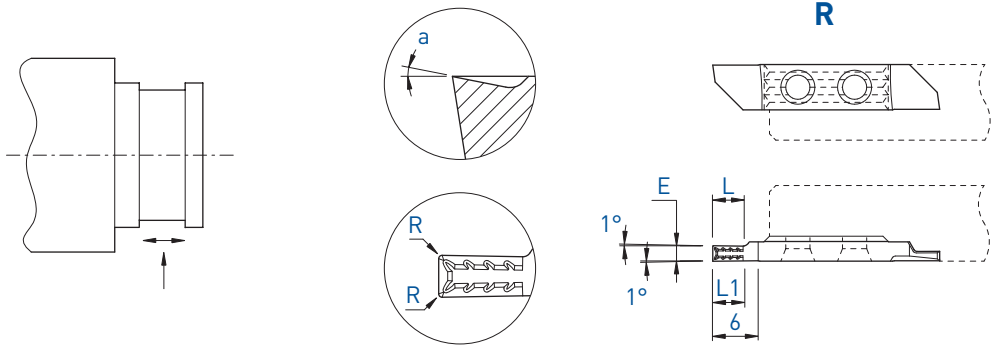

Pour un meilleur contrôle des copeaux  
Für eine bessere Spankontrolle  
For a better chip-control

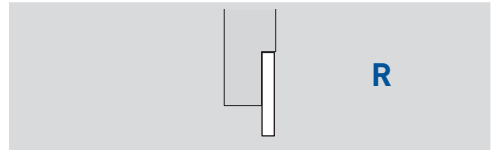

a	E	L	L1	R	Art. N°	TiAIN	TiAlN	LOX	TiN	N (µk20)	HTA	HTiN	HN (µk10)
10°	1.0	2.5	2.5	0.01	744ZXT10-1.0	■	■	■	■		■	□	
	1.5	4	4	0.01	744ZXT10-1.5	■	■	■	□		■	□	
	1.5	4	4	0.08	744ZXT10-1.5-R08	■	■	■	■		■	□	
	2.0	4	4	0.01	744ZXT10-2.0	■	■	■	□		■	□	
	2.0	4	4	0.08	744ZXT10-2.0-R08	■	■	■	□		■	□	
	2.5	5	5	0.01	744ZXT10-2.5	■	■	■	□		■	□	
	2.5	5	5	0.08	744ZXT10-2.5-R08	■	■	■	□		■	□	

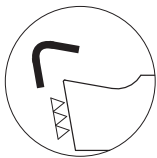

Arête de coupe honée  
Gehonte Schneidkante  
Honed edge

f min: 0.02 mm/U

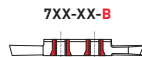

Sur demande pour serrage type B, voir page 1.03  
Wahlweise mit B-Spannsystem, siehe Seite 1.03  
On request for B clamping system, see page 1.03



Gorges  
Einstechen  
Grooving

735 / 745

L

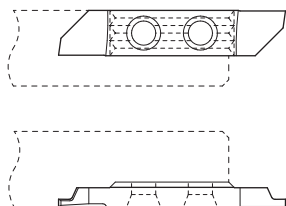

R

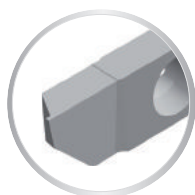
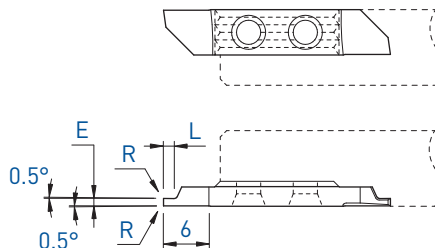

L



R



E ± 0.01			Art. N°	TiAlN	TiN	N (µk20)	HTA	HTiN	HN (µk10)	Art. N°	TiAlN	TiN	N (µk20)	HTA	HTiN	HN (µk10)
	L	R														
0.2	0.2	0	735-0202	■	■	■				745-0202	■	■	■	■	□	■
0.3	0.3	0	735-0303	■	■	■				745-0303	■	■	■	■	□	■
0.4	0.4	0	735-0404	■	■	■				745-0404	■	□	■	■	□	■

7XX-XX-B



Sur demande pour serrage type B, voir page 1.03  
Wahlweise mit B-Spannsystem, siehe Seite 1.03  
On request for B clamping system, see page 1.03

■ = disponible / verfügbar / available  
□ = selon disponibilité du stock / jenach Lagerverfügbarkeit / depending on stock availability

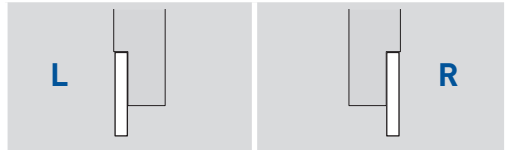
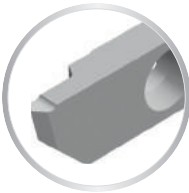
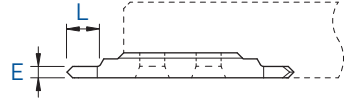
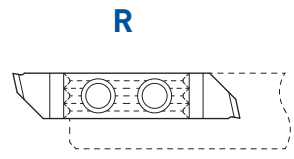
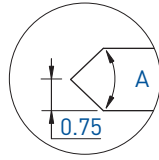
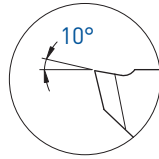
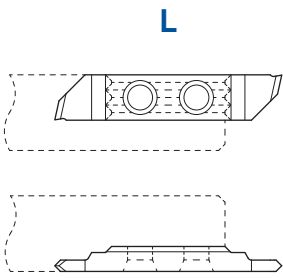

A	E	L	Art. N°	TiAlN	TiN	N (µk20)	Art. N°	TiAlN	TiN	N (µk20)
90°	1.5	4	735X-90-1.5	□	□	□	745X-90-1.5	■	□	■

7XX-XX-B



Sur demande pour serrage type B, voir page 1.03  
Wahlweise mit B-Spannsystem, siehe Seite 1.03  
On request for B clamping system, see page 1.03

Filetage

Gewinde drehen

Threading

736 / 746

L

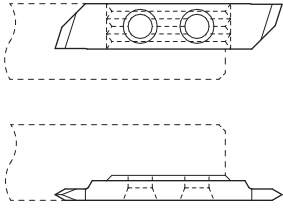

R

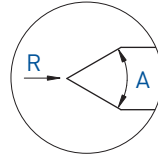
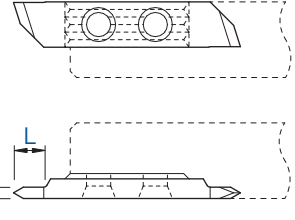

Profil partiel  
Teilprofil  
Partial profile

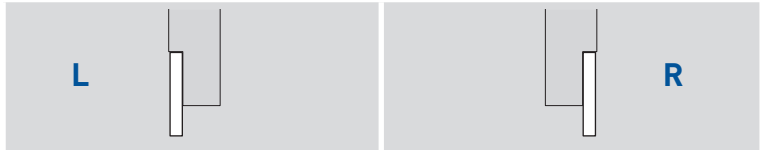

A	E	L	R	L						R								
				Art. N°	TiAlN	TiN	N (µk20)	HTA	HTiN	HN (µk10)	Art. N°	TiAlN	TiN	N (µk20)	HTA	HTiN	HN (µk10)	
60°	1.5	4	0	736-60-1.5	■	■	■					746-60-1.5	■	■	■			
60°	1.5	4	0.02	736-60-1.5-R02	■	■	■					746-60-1.5-R02	■	■	■	□		■
60°	2.0	6	0	736-60-2.0	■	■	■					746-60-2.0	■	■	■			
60°	2.0	6	0.02	736-60-2.0-R02	■	■	■					746-60-2.0-R02	■	■	■			■
55°	1.5	4	0	736-55-1.5	■	■	■					746-55-1.5	■	■	■			
55°	1.5	4	0.02	736-55-1.5-R02	■	■	■					746-55-1.5-R02	■	■	■			
55°	2.0	6	0	736-55-2.0	■	■	■					746-55-2.0	■	■	■			
55°	2.0	6	0.02	736-55-2.0-R02	■	■	■					746-55-2.0-R02	■	■	■			

7XX-XX-B



Sur demande pour serrage type B, voir page 1.03  
Wahlweise mit B-Spannsystem, siehe Seite 1.03  
On request for B clamping system, see page 1.03

■ = disponible / verfügbar / available  
□ = selon disponibilité du stock / jenach Lagerverfügbarkeit / depending on stock availability

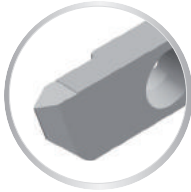
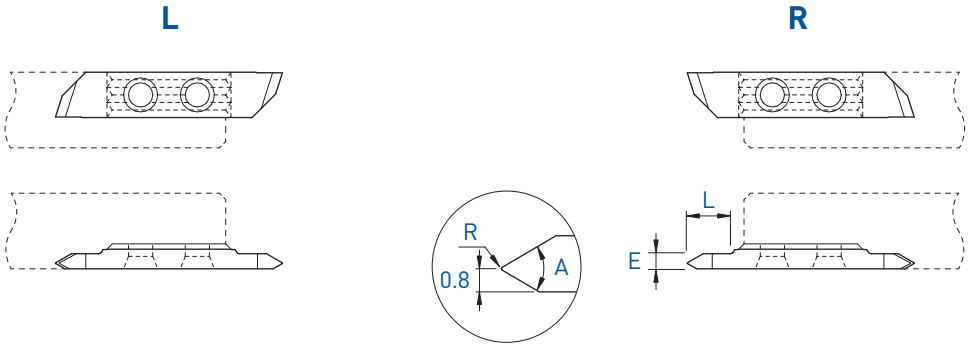

Profil partiel  
Teilprofil  
Partial profile



A	E	L	R	Pas Steigung Pitch P	Art. N°	TiAlN	TiN	N (µk20)	HTA	HTiN	HN (µk10)	Art. N°	TiAlN	TiN	N (µk20)	HTA	HTiN	HN (µk10)
60°	2.0	6	0.06	0.50-1.50	736-A60°	■	■	■				746-A60°	■	■	■	■	□	■

Plaquettes de filetage avec coupe positive 2°, voir page 1.126  
WSP Gewindedrehen mit positivem Schnitt 2°, siehe Seite 1.126  
Threading inserts with positive cut 2°, see page 1.126

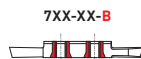

Sur demande pour serrage type B, voir page 1.03  
Wahlweise mit B-Spannsystem, siehe Seite 1.03  
On request for B clamping system, see page 1.03

Filetage

Gewinde drehen

Threading

736-M / 746-M

L

R

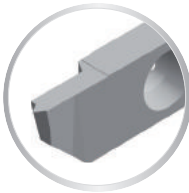
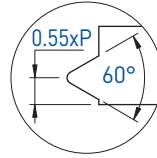
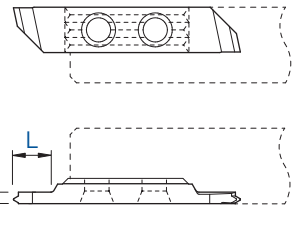
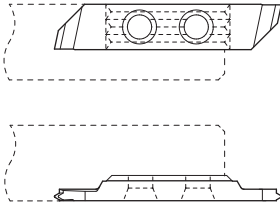

Profil complet métrique  
Metrisches Vollprofil  
Metric full profile

L

R

Pas Steigung Pitch P	E	L	L			R				
			Art. N°	TiAIN	TiN	N (µk20)	Art. N°	TiAIN	TiN	N (µk20)
0.25	1.0	3	736-M-0.25	■	■	■	746-M-0.25	■	■	■
0.30	1.0	3	736-M-0.30	■	■	■	746-M-0.30	■	■	■
0.35	1.0	3	736-M-0.35	■	■	■	746-M-0.35	■	■	■
0.40	1.0	3	736-M-0.40	■	■	■	746-M-0.40	■	■	■
0.45	1.0	3	736-M-0.45	■	■	■	746-M-0.45	■	■	■
0.50	1.0	3	736-M-0.50	■	■	■	746-M-0.50	■	■	■
0.60	1.0	3	736-M-0.60	■	■	■	746-M-0.60	■	■	■
0.70	1.0	3	736-M-0.70	■	■	■	746-M-0.70	■	■	■
0.75	1.0	3	736-M-0.75	■	■	■	746-M-0.75	■	■	■
0.80	1.5	4.5	736-M-0.80	■	■	■	746-M-0.80	■	■	■
1.00	1.5	4.5	736-M-1.00	■	■	■	746-M-1.00	■	■	■
1.25	1.5	4.5	736-M-1.25	■	■	■	746-M-1.25	■	■	■
1.50	2.0	6	736-M-1.50	■	■	■	746-M-1.50	■	■	■
1.75	2.0	6	736-M-1.75	■	■	■	746-M-1.75	■	■	■

Plaquettes de filetage avec coupe positive 2°, voir page 1.127  
WSP Gewindedrehen mit positivem Schnitt 2°, siehe Seite 1.127  
Threading inserts with positive cut 2°, see page 1.127

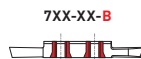

Sur demande pour serrage type B, voir page 1.03  
Wahlweise mit B-Spannsystem, siehe Seite 1.03  
On request for B clamping system, see page 1.03

■ = disponible / verfügbar / available  
□ = selon disponibilité du stock / jenach Lagerverfügbarkeit / depending on stock availability

L

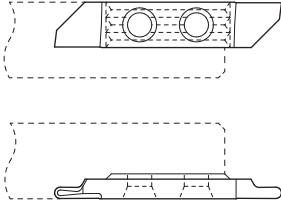

R

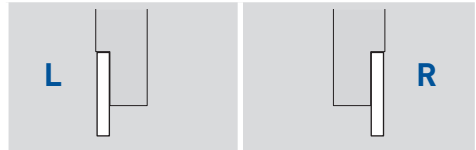
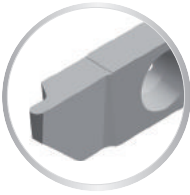
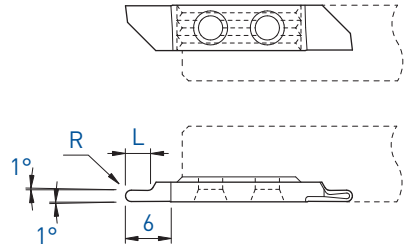

R	L	Art. N°	TiAlN			Art. N°	TiN		
			TiAlN	TiN	N (µm20)		TiAlN	TiN	N (µm20)
0.25	1.5	-				747-R0.25	■	■	■
0.40	2	-				747-R0.4	■	■	■
0.50	2.5	737-R0.5	■	■	■	747-R0.5	■	■	■
0.60	2.5	737-R0.6	■	■	■	747-R0.6	■	■	■
0.75	3	737-R0.75	■	■	■	747-R0.75	■	■	■
0.80	3	737-R0.8	■	■	■	747-R0.8	■	■	■
1.00	4	737-R1.0	■	■	■	747-R1.0	■	■	■

7XX-XX-B



Sur demande pour serrage type B, voir page 1.03  
 Wahlweise mit B-Spannsystem, siehe Seite 1.03  
 On request for B clamping system, see page 1.03

Plaquettes ébauches  
WSP-Rohlinge  
Blank inserts

731-E / 741-E  
731-EP / 741-EP

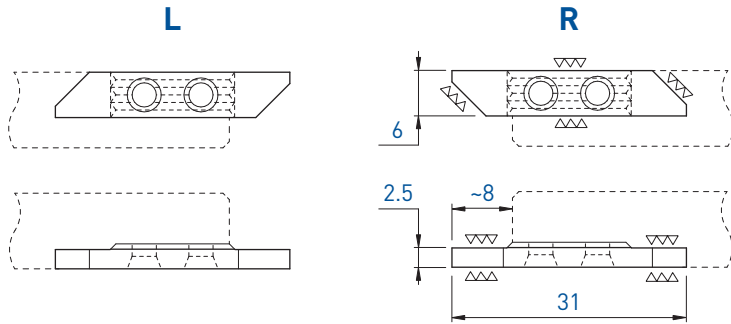
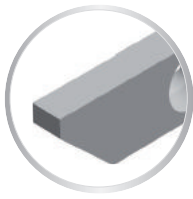

L			R		
Art. N°	N (µk20)	HN (µk10)	Art. N°	N (µk20)	HN (µk10)
731-E	■	■	741-E	■	■



Face de coupe polie  
Polierte Schneidfläche  
Polished cutting face

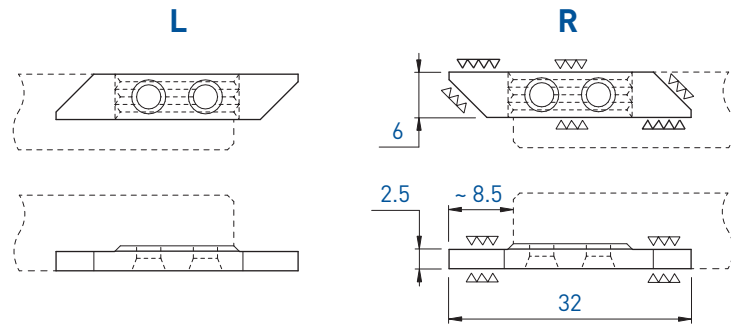

L						R							
Art. N°	TiAlN	TiN	N (µk20)	HTA	HTiN	HN (µk10)	Art. N°	TiAlN	TiN	N (µk20)	HTA	HTiN	HN (µk10)
731-EP	■	■	■	■	■	■	741-EP	■	■	■	■	□	■

7XX-XX-B



Sur demande pour serrage type B,  
voir page 1.03  
Wahlweise mit B-Spannsystem,  
siehe Seite 1.03  
On request for B clamping system,  
see page 1.03

■ = disponible / verfügbar / available  
□ = selon disponibilité du stock / jenach Lagerverfügbarkeit / depending on stock availability

L			R		
Type		Page	Type		Page
<b>750</b>	750	1.70	<b>760</b>	760	1.70
	750-JET	1.71		760/750-D	1.75/1.76
	750RC	1.72		760/750-AX	1.77
<b>751</b>	751	1.78	760-JET	1.71	
	751-E	1.131	760LC	1.73	
	751NXF	1.87/1.97	760-NOVIBRA	1.74	
	751R	1.88	<b>761</b>	761	1.78
	751-R05	1.80		761-E	1.131
	751RAS	1.99		761L	1.88
	751RD	1.98		761LD	1.98
	751R-R05	1.90		761L-R05	1.90
	751RS	1.89		761LS	1.89
	751RU	1.95		761LX12	1.93
	751RZU	1.96		761LX25	1.94
	751RX12	1.93		761LX4	1.91
	751RX25	1.94		761LXF	1.92
	751RX4	1.91		761NXF	1.87/1.97
	751RXF	1.92		761-R05	1.80
	751S	1.79		761S	1.79
	751U	1.85		761U	1.85
	751X12	1.83		761ZU	1.86
	751X25	1.84		761X12	1.83
751X4	1.81	761X25		1.84	
751XF	1.82	761X4		1.81	
<b>752</b>	752	1.100		761XF	1.82
	752PX	1.101	<b>762</b>	762	1.100
	752S	1.106		762PX	1.101
	752X	1.102		762S	1.105
<b>753</b>	753	1.107		762X	1.102
	753P	1.116	762VX-800	1.103	
	753S	1.106	762ZX	1.104	
	753VX-15°	1.113	<b>763</b>	763	1.107
	753VX-8°	1.110		763P	1.116
	753VX-805	1.111		763S	1.106
	753X	1.108		763VUX	1.114
	753XS	1.109		763VX-15°	1.113
	753ZX10	1.115		763VX-8°	1.110
	<b>754</b>	754		1.117	763VX-800
754VS		1.118		763VX-805	1.111
754X		1.119		763X	1.108
754ZX		1.122		763XS	1.109
<b>756</b>	754ZXT	1.124	763ZX10	1.115	
	756-55	1.125	<b>764</b>	764	1.117
	756-60	1.125		764VS	1.118
	756-AG60°	1.126		764X	1.119
	756-G60°	1.126		764X5	1.120
756-M	1.127	764X10		1.121	
<b>757</b>	757	1.129	764ZX	1.122	
	757ZX	1.130	764ZXB	1.123	
			764ZXT	1.124	
			<b>766</b>	766	1.125
				766-AG60°	1.126
				766-G60°	1.126
				766-M	1.127
				766ZX	1.128
			<b>767</b>	767	1.129
				767ZX	1.130

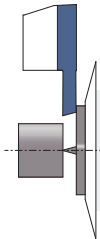
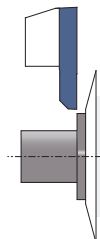
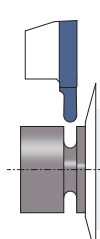

		<b>750 / 760</b> Porte-outils Halter Holders	> 1.70
	<b>751 / 761</b> Tronçonnage Abstechen Parting off		> 1.78
		<b>761L / 751R</b> Tronçonnage - coupe déportée Abstechen - versetztes Schneiden Parting off - cut off line	> 1.88
	<b>752 / 762</b> Tournage avant Vorwärts drehen Front turning		> 1.100
		<b>753 / 763</b> Tournage arrière Rückwärts drehen Back turning	> 1.106
	<b>754 / 764</b> Fonçage-tournage Einstecken und drehen Grooving and turning		> 1.117
		<b>756 / 766</b> Filetage Gewinde drehen Threading	> 1.125
	<b>757 / 767</b> Plaquettes à rayon Radius Wendeplatten Radius inserts		> 1.129
		Plaquettes ébauches WSP-Rohlinge Blank inserts	> 1.131

L

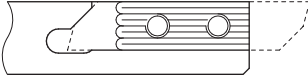

R

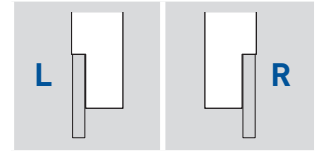
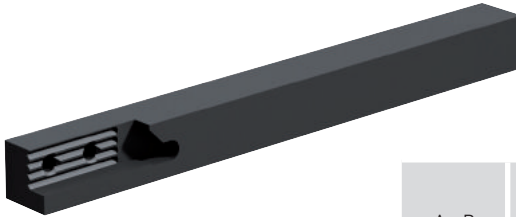
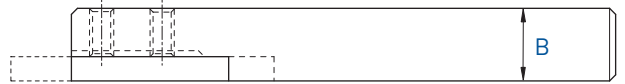
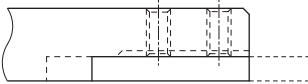
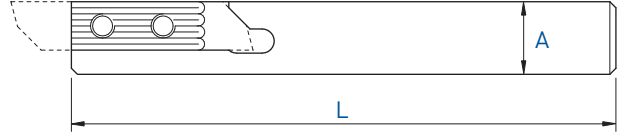

Serrage standard A  
Standard Spannsystem A  
Standard clamping system A

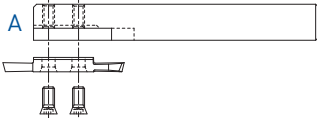

A x B	L	Serrage Spannsystem Clamping	Art. N°	Art. N°
10 x 10	115	A	750-10	760-10
10 x 10	115	A + B	750-10-AB	760-10-AB
10 x 10	50	A	750-10-50	760-10-50
12 x 12	130	A	750-12	760-12
12 x 12	130	A + B	750-12-AB	760-12-AB
12 x 12	90	A	750-12-90	760-12-90
12 x 12	90	A + B	750-12-90-AB	760-12-90-AB
12.7 x 12.7	130	A + B	750-12.7	760-12.7
14 x 14	130	A + B	750-14	760-14
16 x 16	130	A + B	750-16	760-16
16 x 16	75	A + B	750-16-75	760-16-75
20 x 20	120	A + B	750-20	760-20
25 x 25	140	A	760/750-25	

Serrage A + B  
Spannsystem A + B  
Clamping system A + B

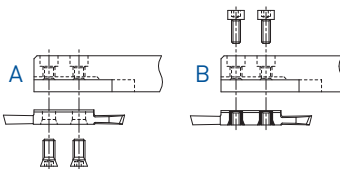

760/750-25  
R + L



Chaque support est livré avec vis et clé.  
Jeder Halter wird mit Spannschraube(n) und Schlüssel geliefert.  
Screw(s) and key are included with each tool holder.

Porte-outils avec arrosage intégré  
 Halter mit integrierter Kühlmittelzufuhr  
 Holders with integrated coolant supply

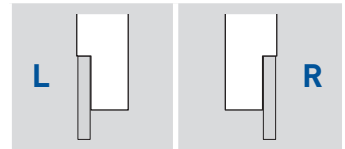
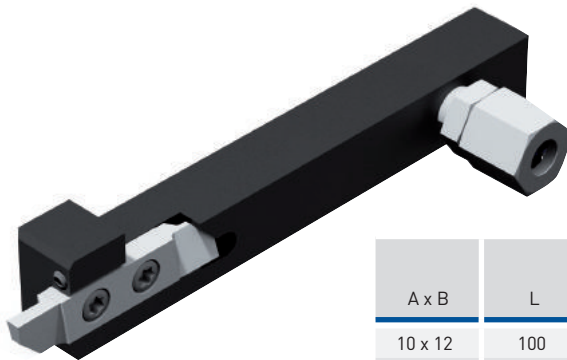
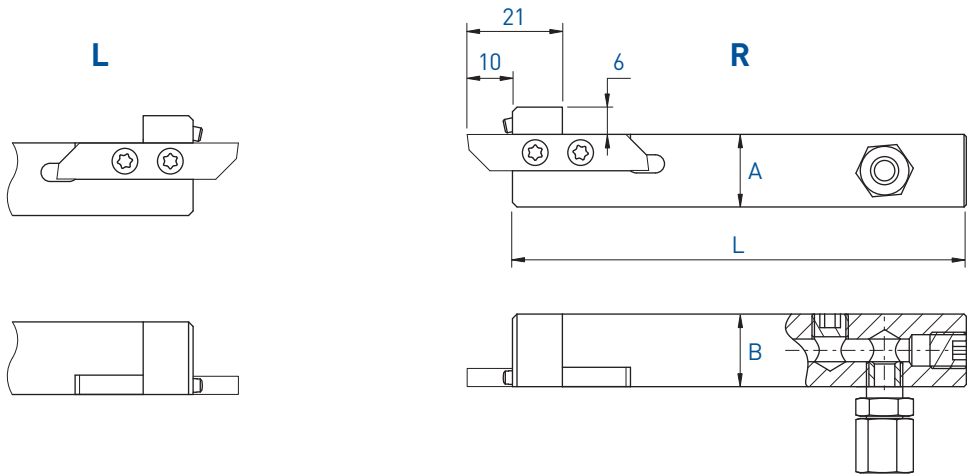

750-JET / 760-JET

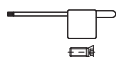

A x B	L	Serrage Spannsystem Clamping	Art. N°	Art. N°
10 x 12	100	A + B	750-1012-JET	760-1012-JET
10 x 12	80	A + B	-	760-1012-80-JET <b>new</b>
12 x 12	100	A + B	750-12-JET	760-12-JET
12.7 x 12.7	100	A + B	750-12.7-JET	760-12.7-JET
16 x 16	100	A + B	750-16-JET	760-16-JET
20 x 20	100	A + B	750-20-JET	760-20-JET

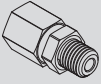

Chaque support est livré avec vis et clé.  
 Jeder Halter wird mit Spannschraube(n)  
 und Schlüssel geliefert.  
 Screw(s) and key are included with each  
 tool holder.

Pièces de rechange Ersatzteile Spare parts			Buse Düse Nozzle 
	Art. N°	Art. N°	Art. N°
750-JET / 760-JET	J-M8X1-D6	JB-M8X1	JJ-M3X6-D1.5

**Porte-outils**  
**Halter**  
**Holder**

**Coupe à droite déportée**  
**Versetztes Rechtsschneiden**  
**Right cut off line**

**750RC**

Utiliser des plaquettes type 751R  
 WSP Typ 751R verwenden  
 Use inserts type 751R

Voir pages 1.88 - 1.99  
 Siehe Seiten 1.88 - 1.99  
 See pages 1.88 - 1.99

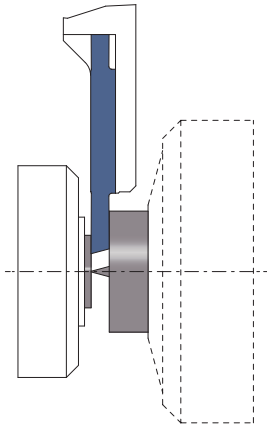
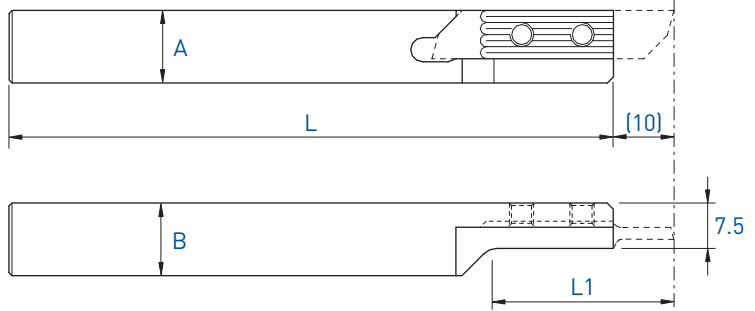

<b>L (R)</b>			
Coupe à droite déportée Versetztes Rechtsschneiden Right cut off line			
A x B	L	L1	Art. N°
12 x 12	130	30	<b>750RC-12</b>
16 x 16	130	40	<b>750RC-16</b>

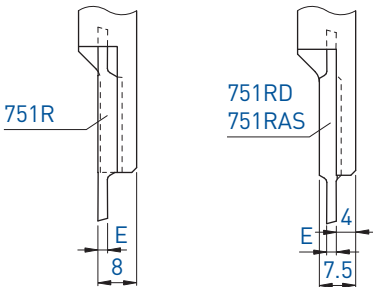

(p. 1.98 - 1.99)



Chaque support est livré avec vis et clé.  
 Jeder Halter wird mit Spanschraube(n) und Schlüssel geliefert.  
 Screw(s) and key are included with each tool holder.

Porte-outils

Halter

Holder

Coupe à gauche déportée

Versetztes Linksschneiden

Left cut off line

760LC

Utiliser des plaquettes type 761L  
WSP Typ 761L verwenden  
Use insets type 761L

Voir pages 1.88 - 1.94 + 1.98  
Siehe Seiten 1.88 - 1.94 + 1.98  
See pages 1.88 - 1.94 + 1.98

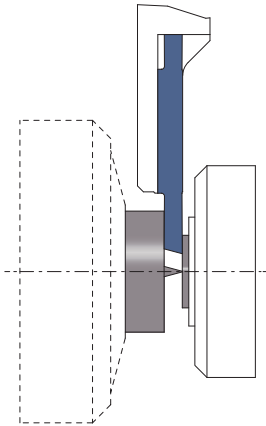
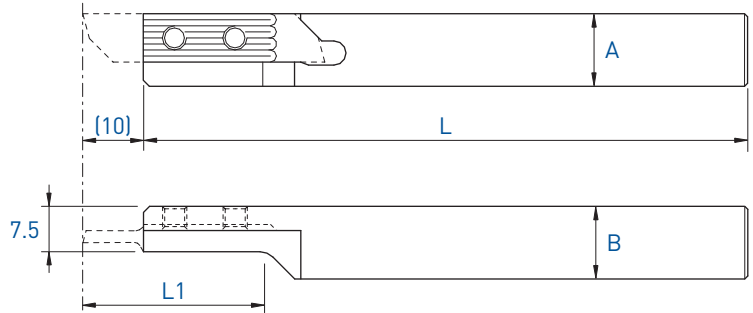

R (L)

Coupe à gauche déportée  
Versetztes Linksschneiden  
Left cut off line

A x B	L	L1	Art. N°
16 x 16	130	40	760LC-16

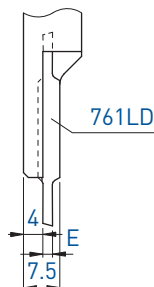
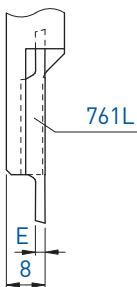

(p. 1.98)



Chaque support est livré avec vis et clé.  
Jeder Halter wird mit Spannschraube(n) und Schlüssel geliefert.  
Screw(s) and key are included with each tool holder.

R

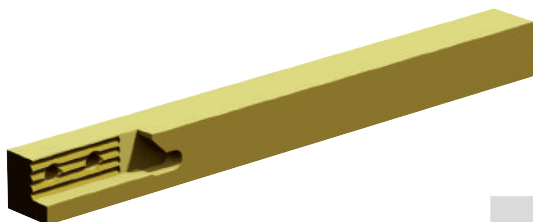
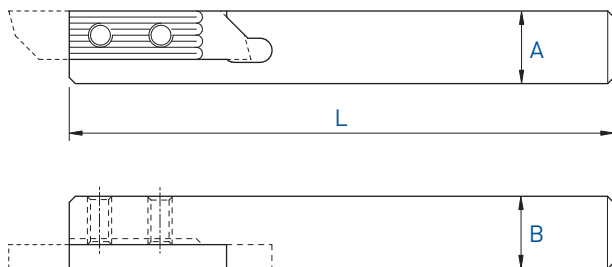

A x B	L	Serrage Spannsystem Clamping	Art. N°
10 x 10	115	A	<b>760-10-NOVIBRA</b>
12 x 12	130	A	<b>760-12-NOVIBRA</b>

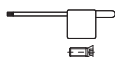

Chaque support est livré avec vis et clé.  
 Jeder Halter wird mit Spannschraube(n) und Schlüssel geliefert.  
 Screw(s) and key are included with each tool holder.

Porte-outils

Halter

Holders

760 / 750-D10

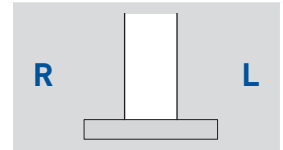
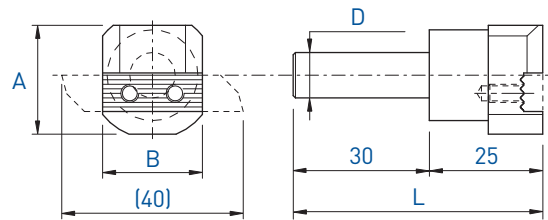

A x B	L	D	Art. N°
24 x 22	55	10	760/750-D10

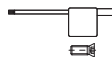

Chaque support est livré avec vis et clé.  
 Jeder Halter wird mit Spannschraube(n) und Schlüssel geliefert.  
 Screw(s) and key are included with each tool holder.

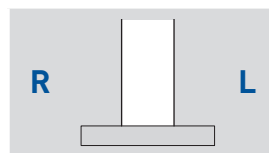
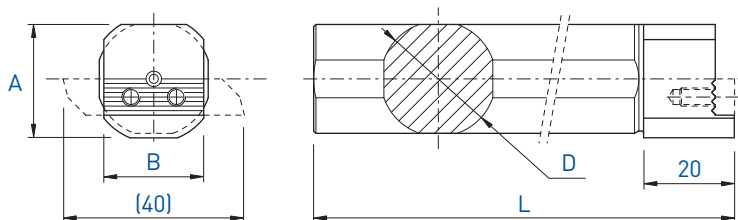

A x B	L	D	Art. N°
25 x 22	160	16	<b>760/750-D16</b>
25 x 22	160	19.05	<b>760/750-D19.05</b>
25 x 22	110	19.05	<b>760/750-D19.05-S</b>
25 x 22	160	20	<b>760/750-D20</b>
25 x 22	110	22	<b>760/750-D22</b>
25 x 22	200	25	<b>760/750-D25</b>
25 x 22	200	25.4	<b>760/750-D25.4</b>
25 x 22	125	25.4	<b>760/750-D25.4-S</b>

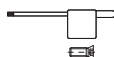

Chaque support est livré avec vis et clé.  
 Jeder Halter wird mit Spannschraube(n) und Schlüssel geliefert.  
 Screw(s) and key are included with each tool holder.



Porte-outils  
 Halter  
 Holders

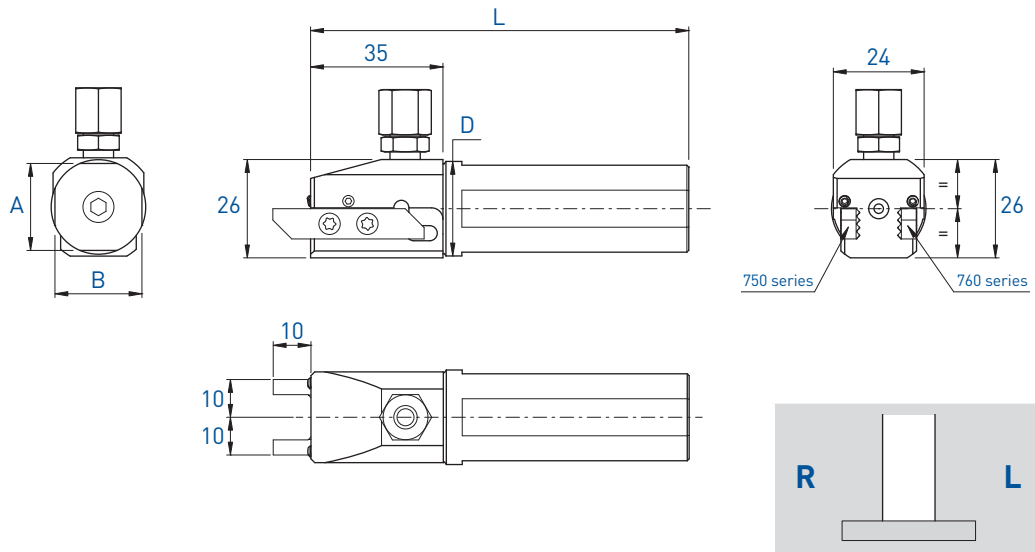

760 / 750-AX

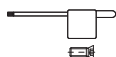

A x B	L	D	Art. N°
23 x 23	100	25	760/750-AX-D25-JET
23 x 23	100	25.4	760/750-AX-D25.4-JET

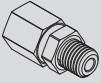

Chaque support est livré avec vis et clé.  
 Jeder Halter wird mit Spannschraube(n)  
 und Schlüssel geliefert.  
 Screw(s) and key are included with each  
 tool holder.

Pièces de rechange Ersatzteile Spare parts			Buse Düse Nozzle 
	Art. N°	Art. N°	Art. N°
760/750-AX	J-M8X1-D6	JB-M8X1	JJ-M3X6-D1.5

L

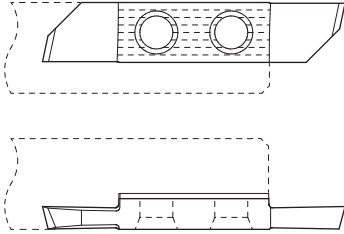

R

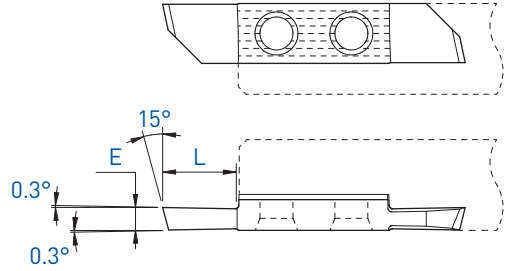

L



R



E	L	Art. N°	TiAlN	TiN	N (µk20)	HTA	HTiN	HN (µk10)	Art. N°	TiAlN	TiAlX	TiN	N (µk20)	HTA	HTiN	HN (µk10)
1.0	5	751-1.0	■	■	■	■	□	■	761-1.0	■	■	■	■	■	■	■
1.2	5	751-1.2	■	■	■				761-1.2	■	■	■	■	■	□	■
1.5	7.5	751-1.5	■	■	■	■	□	■	761-1.5	■	■	■	■	■	■	■
1.8	7.5	751-1.8	■	■	■				761-1.8	■	■	■	■	■	□	■
2.0	10	751-2.0	■	■	■	■	□	■	761-2.0	■	■	■	■	■	■	■
2.2	10	751-2.2	■	■	■				761-2.2	■	■	■	■	■	□	■
2.5	10	751-2.5	■	■	■	■	□	■	761-2.5	■	■	■	■	■	■	■
3.0	10	751-3.0	■	■	■				761-3.0	■	■	■	■	■	□	■

7XX-XX-B



Sur demande pour serrage type B, voir page 1.03  
Wahlweise mit B-Spannsystem, siehe Seite 1.03  
On request for B clamping system, see page 1.03

Tronçonnage  
Abstechen  
Parting off

751S / 761S

L

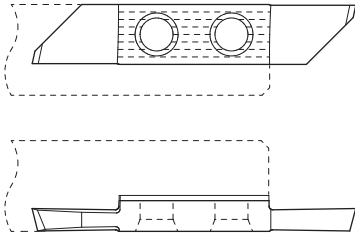

R

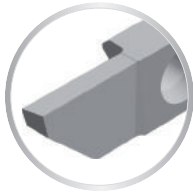
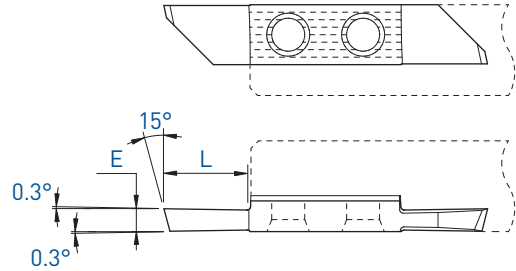

L



R



E	L	Art. N°	TiAlN	TiN	N (µk20)	HTA	HTiN	HN (µk10)	Art. N°	TiAlN	TiAlX	TiN	N (µk20)	HTA	HTiN	HN (µk10)
2.0	11.5	751S-2.0	■	■	■	■	□	■	761S-2.0	■	■	■	■	■	□	■
2.2	11.5	751S-2.2	■	■	■				761S-2.2	■	■	■	■	■	□	■
2.5	11.5	751S-2.5	■	■	■	■	□	■	761S-2.5	■	■	■	■	■	□	■
3.0	11.5	751S-3.0	■	■	■				761S-3.0	■	■	■	■	■	□	■

7XX-XX-B



Sur demande pour serrage type B, voir page 1.03  
Wahlweise mit B-Spannsystem, siehe Seite 1.03  
On request for B clamping system, see page 1.03

■ = disponible / verfügbar / available  
□ = selon disponibilité du stock / jenach Lagerverfügbarkeit / depending on stock availability

Tronçonnage  
Abstechen  
Parting off

## 751-R05 / 761-R05

L

R

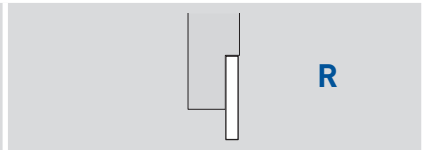
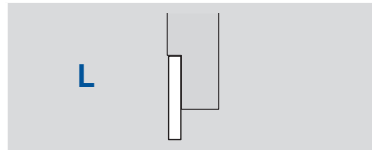
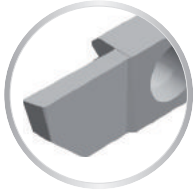
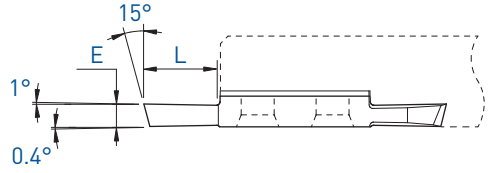
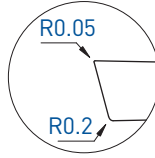
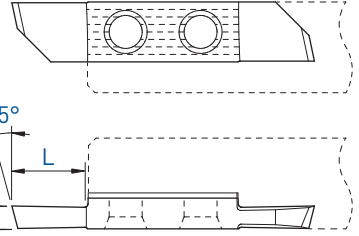
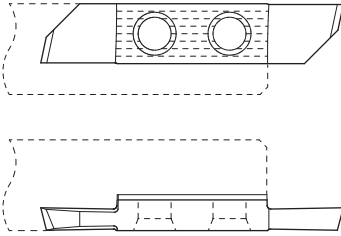

E	L	Art. N°	L			R			HTA	HTiN	HN [µk10]	
			TiAlN	TiN	N [µk20]	TiAlN	TiAlX	TiN				N [µk20]
1.5	7.5	751-1.5-R05	■	■	■					■	□	■
2.0	10	751-2.0-R05	■	■	■					■	□	■
2.5	10	751-2.5-R05	■	■	■					■	□	■

7XX-XX-B

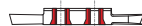

Sur demande pour serrage type B, voir page 1.03  
Wahlweise mit B-Spannsystem, siehe Seite 1.03  
On request for B clamping system, see page 1.03

Tronçonnage  
Abstechen  
Parting off

751X4 / 761X4

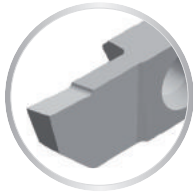
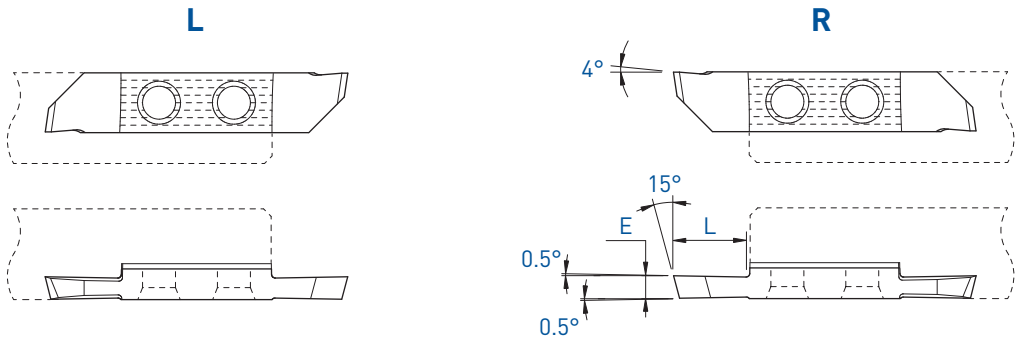

		L						R							
E	L	Art. N°	TiAlN	TiN	N (µk20)	HTA	HTiN	HN (µk10)	Art. N°	TiAlN	TiN	N (µk20)	HTA	HTiN	HN (µk10)
1.5	7.5	-							761X4-1.5	■	■	■			
2.0	10	751X4-2.0	■	■	■	■	□	■	761X4-2.0	■	■	■	■	□	■
2.5	10	-							761X4-2.5	■	■	■			

7XX-XX-B



Sur demande pour serrage type B, voir page 1.03  
Wahlweise mit B-Spannsystem, siehe Seite 1.03  
On request for B clamping system, see page 1.03

■ = disponible / verfügbar / available  
□ = selon disponibilité du stock / jenach Lagerverfügbarkeit / depending on stock availability

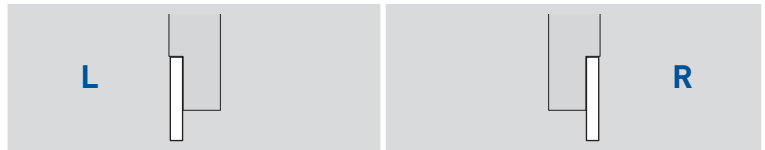
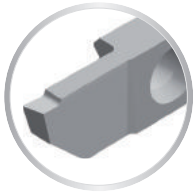
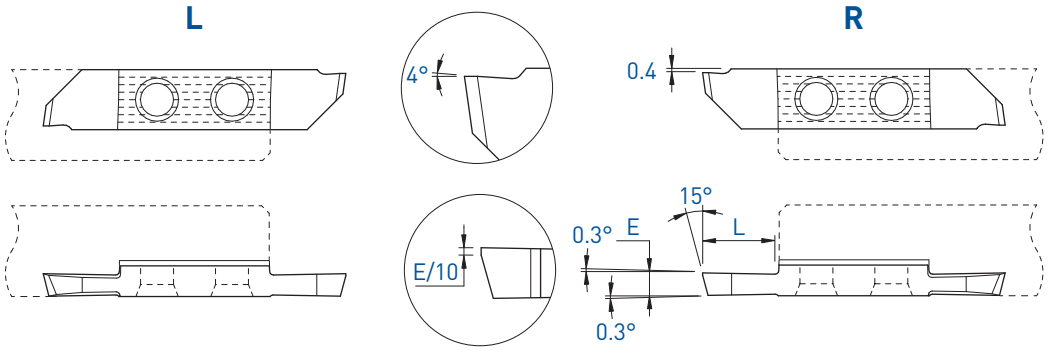

E	L	Art. N°	L			R			Art. N°	R					
			TiAlN	TiN	N (µk20)	HTA	HTiN	HN (µk10)		TiAlN	TiN	N (µk20)	HTA	HTiN	HN (µk10)
1.5	7.5	751XF-1.5	■	■	■	■	□	■	761XF-1.5	■	■	■	■	□	■
2.0	10	751XF-2.0	■	■	■	■	■	■	761XF-2.0	■	■	■	■	■	■
2.2	10	751XF-2.2	■	■	■				761XF-2.2	■	■	■			
2.5	10	751XF-2.5	■	■	■	■	□	■	761XF-2.5	■	■	■			
3.0	10	751XF-3.0	■	■	■				761XF-3.0	■	■	■	■	□	■

7XX-XX-B



Sur demande pour serrage type B, voir page 1.03  
Wahlweise mit B-Spannsystem, siehe Seite 1.03  
On request for B clamping system, see page 1.03

Tronçonnage  
Abstechen  
Parting off

751X12 / 761X12

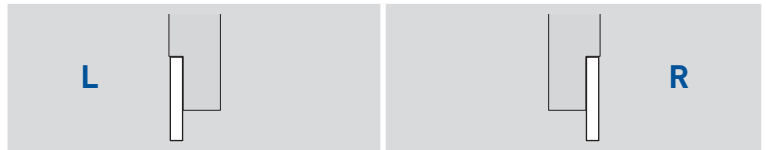
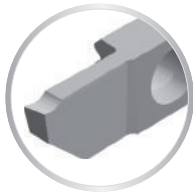
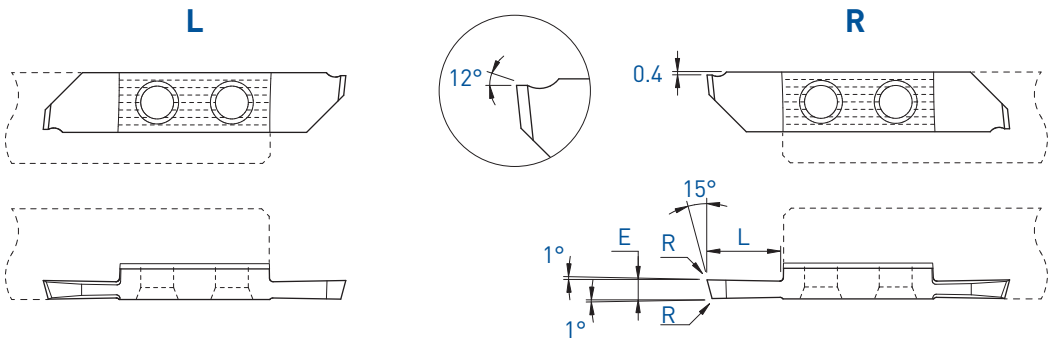

E	L	R	Art. N°	TiAlN	TiN	N (µk20)	HTA	HTiN	HN (µk10)	Art. N°	TiAlN	TiN	N (µk20)	HTA	HTiN	HN (µk10)
1.5	7.5	0.03	751X12-1.5	■	■	■	■	□	■	761X12-1.5	■	■	■	■	□	■
2.0	10	0.03	751X12-2.0	■	■	■	■	□	■	761X12-2.0	■	■	■	■	□	■
2.5	10	0.03	751X12-2.5	■	■	■	■			761X12-2.5	■	■	■	■	□	■

7XX-XX-B

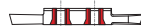

Sur demande pour serrage type B, voir page 1.03  
Wahlweise mit B-Spannsystem, siehe Seite 1.03  
On request for B clamping system, see page 1.03

■ = disponible / verfügbar / available  
□ = selon disponibilité du stock / jenach Lagerverfügbarkeit / depending on stock availability

# TOP-LINE

- Tronçonnage
- Abstechen
- Parting off

## 751X25 / 761X25

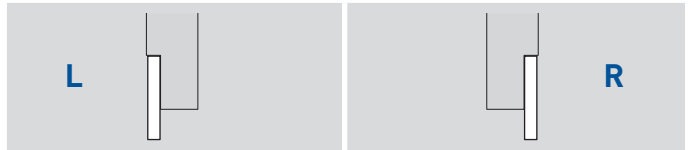
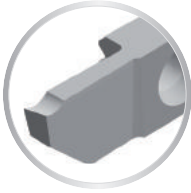
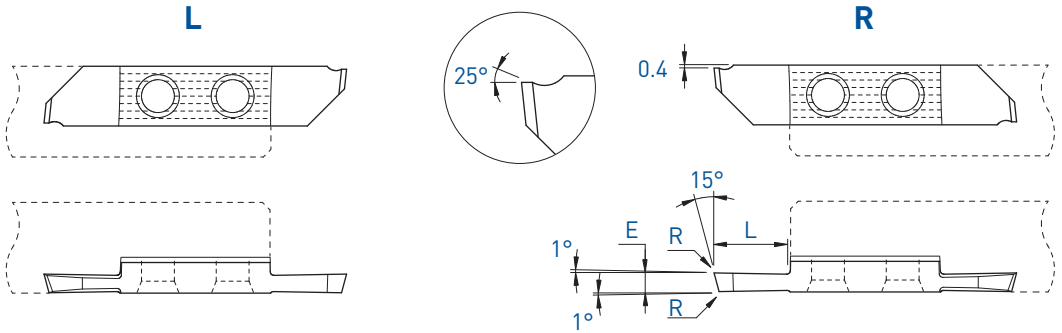

			L						R							
E	L	R	Art. N°	TiAlN	TiN	N (µk20)	HTA	HTiN	HN (µk10)	Art. N°	TiAlN	TiN	N (µk20)	HTA	HTiN	HN (µk10)
1.5	7.5	0.03	751X25-1.5	■	■	■	■	□	■	761X25-1.5	■	■	■			
2.0	10	0.03	751X25-2.0	■	■	■				761X25-2.0	■	■	■	■	□	■
2.5	10	0.03	751X25-2.5	■	■	■				761X25-2.5	■	■	■	■	□	■

7XX-XX-B

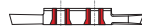

Sur demande pour serrage type B, voir page 1.03  
 Wahlweise mit B-Spannsystem, siehe Seite 1.03  
 On request for B clamping system, see page 1.03



Tronçonnage

Abstechen

Parting off

751U / 761U

L

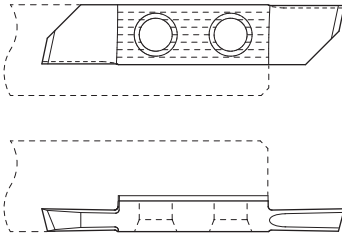

R

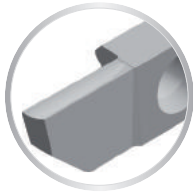
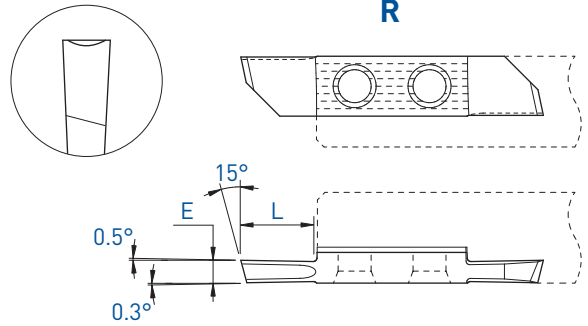

L



R



E	L	Art. N°	TiAlN	TiN	N (µk20)	HTA	HTiN	HN (µk10)	Art. N°	TiAlN	TiN	N (µk20)	HTA	HTiN	HN (µk10)
1.5	7.5	-							761U-1.5	■	□	■	■	□	■
2.0	10	751U-2.0	■	■	■				761U-2.0	■	■	■	□	□	■

7XX-XX-B



Sur demande pour serrage type B, voir page 1.03  
Wahlweise mit B-Spannsystem, siehe Seite 1.03  
On request for B clamping system, see page 1.03

■ = disponible / verfügbar / available

□ = selon disponibilité du stock / jenach Lagerverfügbarkeit / depending on stock availability

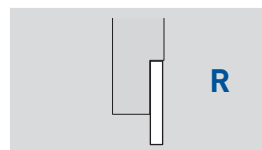
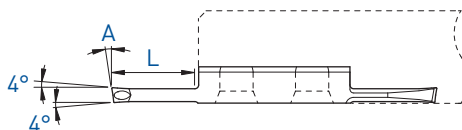
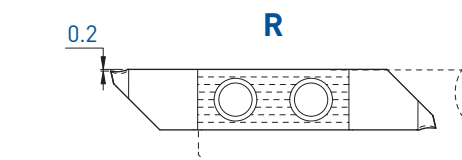
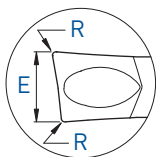
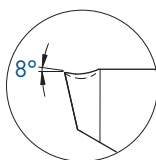

E	A	L	R	Art. N°	TiAlN N (µk20)
2.0	0°	11	0.10	761ZU8-2.0-R10	■
2.0	8°	11	0.10	761ZU8-2.0-8°-R10	■

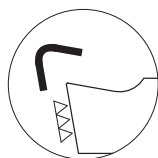

Arête de coupe honée  
Gehonte Schneidkante  
Honed edge

f min: 0.02 mm/U

7XX-XX-B



Sur demande pour serrage type B, voir page 1.03  
Wahlweise mit B-Spannsystem, siehe Seite 1.03  
On request for B clamping system, see page 1.03

Tronçonnage  
Abstechen  
Parting off

751NXF / 761NXF

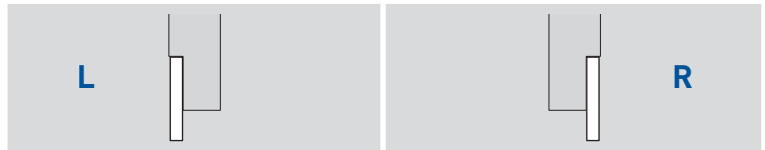
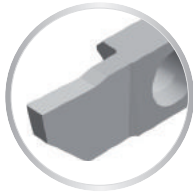
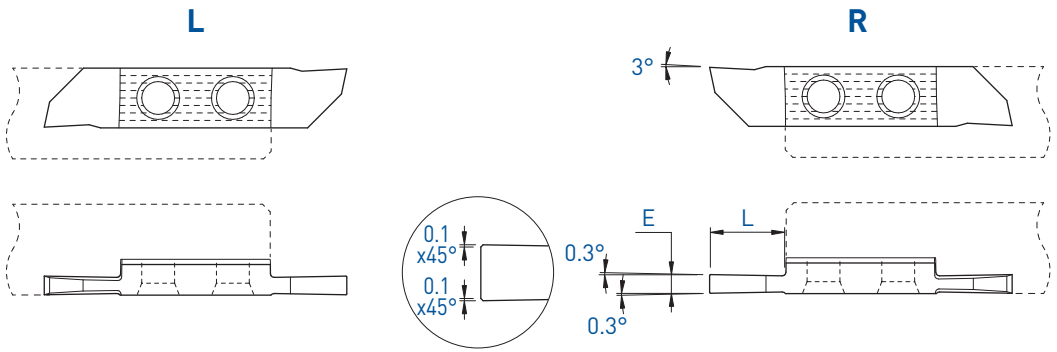

E	L	Art. N°	L			R		
			TiAlN	TiN	N (µk20)	HTA	HTiN	HN (µk10)
2.0	10	751NXF-2.0	■	■	■	■	□	■
2.5	10	751NXF-2.5	■	■	■			
3.0	10	751NXF-3.0	■	■	■			

7XX-XX-B



Sur demande pour serrage type B, voir page 1.03  
Wahlweise mit B-Spannsystem, siehe Seite 1.03  
On request for B clamping system, see page 1.03

■ = disponible / verfügbar / available  
□ = selon disponibilité du stock / jenach Lagerverfügbarkeit / depending on stock availability

Tronçonnage

Abstechen

Parting off

Coupe déportée

Versetztes Schneiden

Cut off line

## 761L / 751R

### Cut L

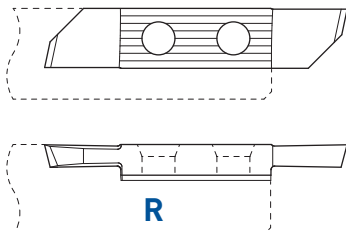

### Cut R

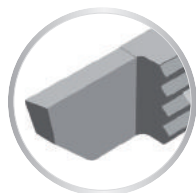
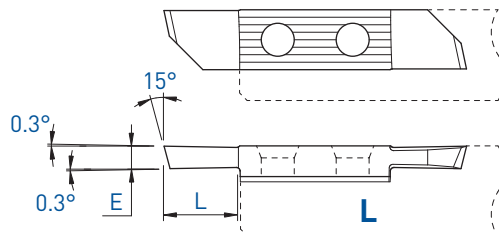

#### R (L)

Coupe à gauche déportée  
Versetztes Linksschneiden  
Left cut off line

#### L (R)

Coupe à droite déportée  
Versetztes Rechtsschneiden  
Right cut off line

E	L	Art. N°	TiAlN	TiN	N (µk20)	HTA	HTiN	HN (µk10)	Art. N°	TiAlN	TiAlX	TiN	N (µk20)	HTA	HTiN	HN (µk10)
1.0	5	761L-1.0	■	■	■	■	□	■	751R-1.0	■	■	■	■	■	□	■
1.5	7.5	761L-1.5	■	■	■	■	□	■	751R-1.5	■	■	■	■	■	□	■
1.8	7.5	761L-1.8	■	■	■	■	□	■	751R-1.8	■	■	■	■	■	□	■
2.0	10	761L-2.0	■	■	■	■	□	■	751R-2.0	■	■	■	■	■	■	■
2.2	10	761L-2.2	■	■	■	■	□	■	751R-2.2	■	■	■	■	■	■	■
2.5	10	761L-2.5	■	■	■	■	□	■	751R-2.5	■	■	■	■	■	■	■
3.0	10	761L-3.0	■	■	■	■	□	■	751R-3.0	■	■	■	■	■	□	■

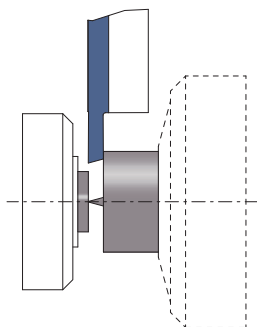

Tronçonnage  
Abstechen  
Parting off

Coupe déportée  
Versetztes Schneiden  
Cut off line

761LS / 751RS

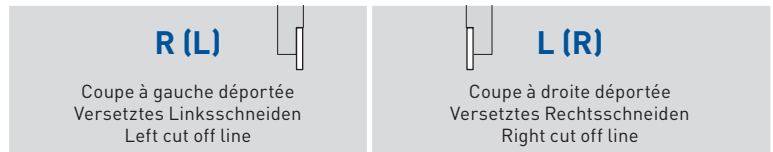
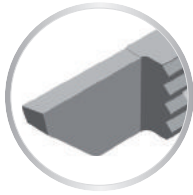
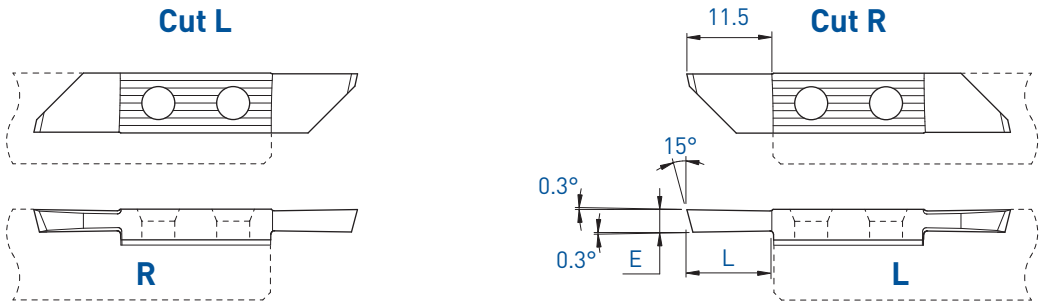

		R (L) Coupe à gauche déportée Versetztes Linksschneiden Left cut off line							L (R) Coupe à droite déportée Versetztes Rechtsschneiden Right cut off line							
E	L	Art. N°	TiAlN	TiN	N (µk20)	HTA	HTiN	HN (µk10)	Art. N°	TiAlN	TiAlX	TiN	N (µk20)	HTA	HTiN	HN (µk10)
1.0	5.5	761LS-1.0	■	■	■	■	□	■	751RS-1.0	■	■	■	■	■	□	■
1.5	8	761LS-1.5	■	■	■	■	□	■	751RS-1.5	■	■	■	■	■	□	■
2.0	11.5	761LS-2.0	■	■	■				751RS-2.0	■	■	■	■	■	■	■
2.2	11.5	761LS-2.2	■	■	■				751RS-2.2	■	■	■	■	■	□	■
2.5	11.5	761LS-2.5	■	■	■				751RS-2.5	■	■	■	■	■	□	■
3.0	11.5	761LS-3.0	■	■	■				751RS-3.0	■	■	■	■	■	□	■

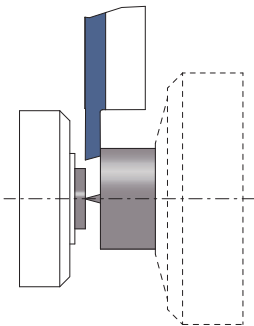

# TOP-LINE

Tronçonnage  
Abstechen  
Parting off

Coupe déportée  
Versetztes Schneiden  
Cut off line

## 761L-R05 / 751R-R05

Cut L

Cut R

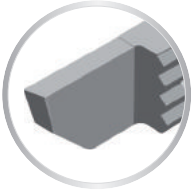
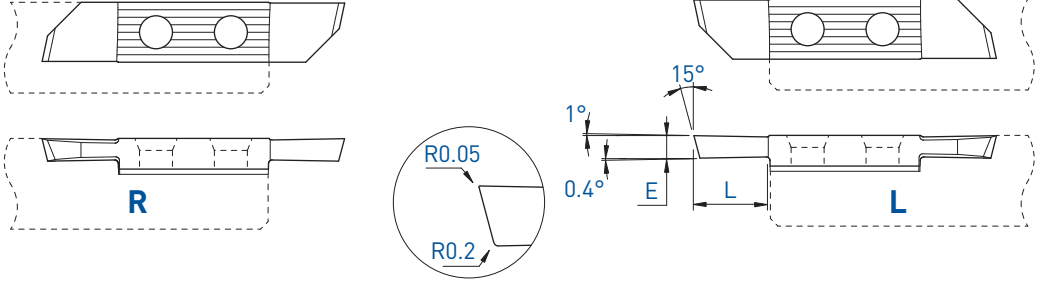

R (L)

Coupe à gauche déportée  
Versetztes Linksschneiden  
Left cut off line

L (R)

Coupe à droite déportée  
Versetztes Rechtsschneiden  
Right cut off line

E	L	Art. N°	TiAlN	TiN	N (µk20)	HTA	HTiN	HN (µk10)	Art. N°	TiAlN	TiAlX	TiN	N (µk20)	HTA	HTiN	HN (µk10)
1.5	7.5	761L-1.5-R05	■	■	■				751R-1.5-R05	■	■	■	■	■	□	■
2.0	10	761L-2.0-R05	■	■	■				751R-2.0-R05	■	■	■	■			

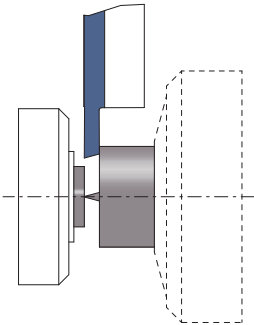

Tronçonnage  
Abstechen  
Parting off

Coupe déportée  
Versetztes Schneiden  
Cut off line

761LX4 / 751RX4

Cut L

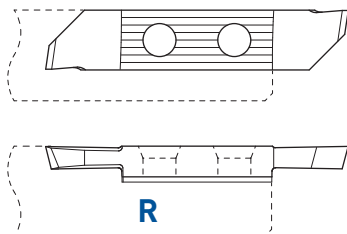

Cut R

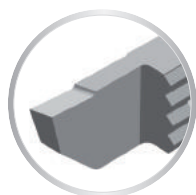
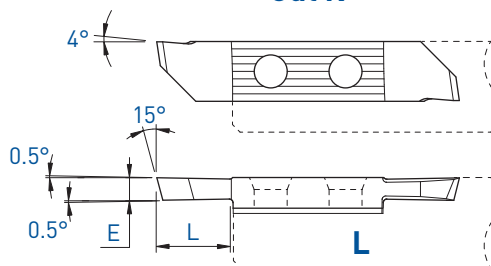

R (L)

Coupe à gauche déportée  
Versetztes Linksschneiden  
Left cut off line

L (R)

Coupe à droite déportée  
Versetztes Rechtsschneiden  
Right cut off line

E	L	Art. N°	TiAlN	TiN	N [µk20]	HTA	HTiN	HN [µk10]	Art. N°	TiAlN	TiN	N [µk20]	HTA	HTiN	HN [µk10]
1.5	7.5	-							751RX4-1.5	■	■	■	■	■	■
2.0	10	761LX4-2.0	■	■	■				751RX4-2.0	■	■	■	■	■	■
2.5	10	-							751RX4-2.5	■	■	■			

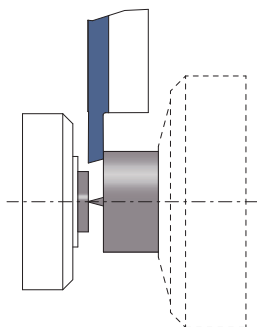

Tronçonnage  
Abstechen  
Parting off

Coupe déportée  
Versetztes Schneiden  
Cut off line

761LXF / 751RXF

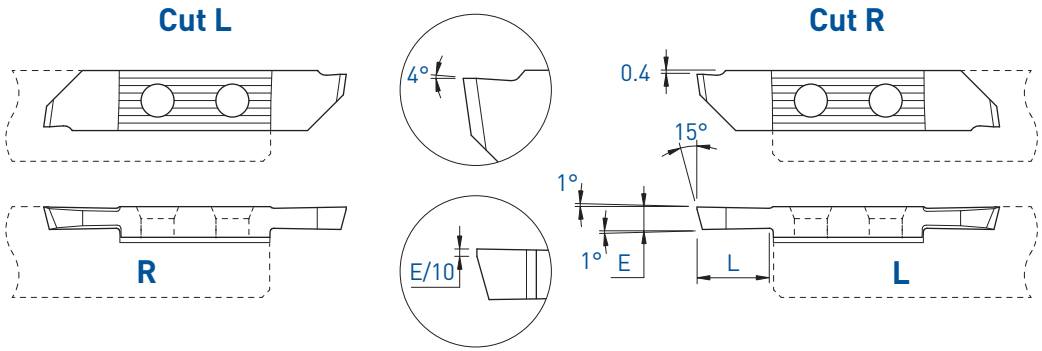

R (L)	L (R)
Coupe à gauche déportée Versetztes Linksschneiden Left cut off line	Coupe à droite déportée Versetztes Rechtsschneiden Right cut off line

E	L	Art. N°	TiAlN	TiN	N (µk20)	HTA	HTiN	HN (µk10)	Art. N°	TiAlN	TiN	N (µk20)	HTA	HTiN	HN (µk10)
1.5	7.5	-	■	■	■				751RXF-1.5	■	■	■	■	□	■
2.0	10	761LXF-2.0	■	■	■				751RXF-2.0	■	■	■	■	■	■
2.5	10	761LXF-2.5	■	■	■				751RXF-2.5	■	■	■	■	□	■
3.0	10	761LXF-3.0	■	■	■				751RXF-3.0	■	■	■	■	□	■

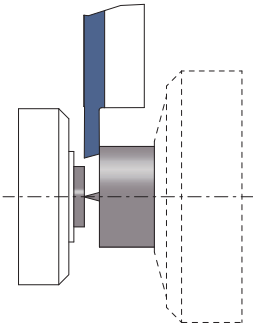



Tronçonnage  
Abstechen  
Parting off

Coupe déportée  
Versetztes Schneiden  
Cut off line

761LX12 / 751RX12

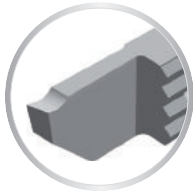
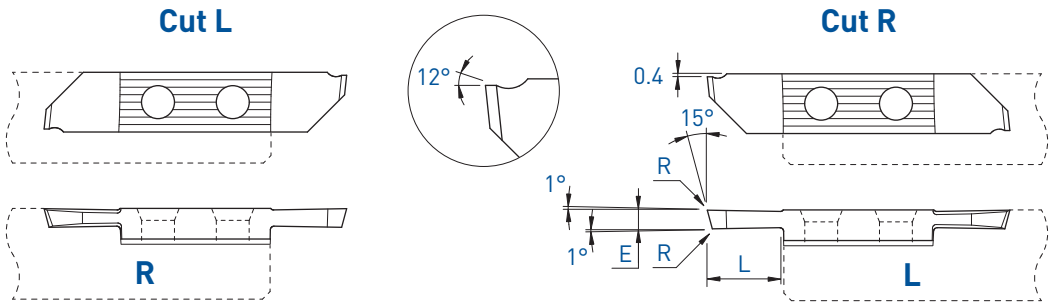

			R (L) Coupe à gauche déportée Versetztes Linksschneiden Left cut off line					L (R) Coupe à droite déportée Versetztes Rechtsschneiden Right cut off line								
E	L	R	Art. N°	TiAlN	TiN	N [µk20]	HTA	HTiN	HN [µk10]	Art. N°	TiAlN	TiN	N [µk20]	HTA	HTiN	HN [µk10]
1.5	7.5	0.03	-							751RX12-1.5	■	■	■			
2.0	10	0.03	761LX12-2.0	■	■	■				751RX12-2.0	■	■	■	■	■	■

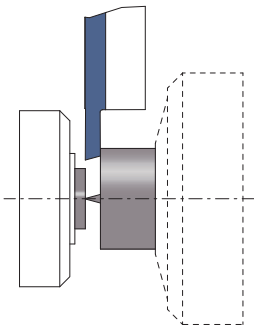

# TOP-LINE

Tronçonnage  
Abstechen  
Parting off

Coupe déportée  
Versetztes Schneiden  
Cut off line

761LX25 / 751RX25

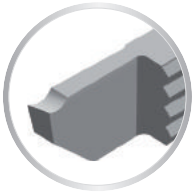
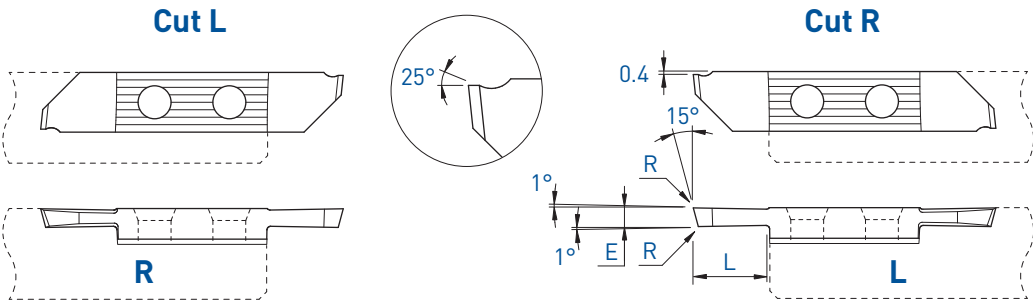

R (L)	L (R)
Coupe à gauche déportée Versetztes Linksschneiden Left cut off line	Coupe à droite déportée Versetztes Rechtsschneiden Right cut off line

E	L	R	Art. N°	TiAIN	TiN	N (µk20)	Art. N°	TiAIN	TiN	N (µk20)
2.0	10	0.03	761LX25-2.0	■	■	■	751RX25-2.0	■	■	■

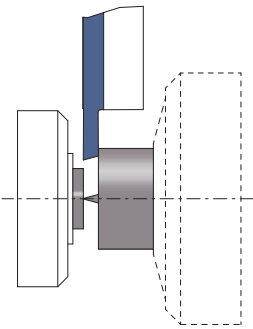

Tronçonnage  
Abstechen  
Parting off

Coupe déportée  
Versetztes Schneiden  
Cut off line

751RU

Cut R

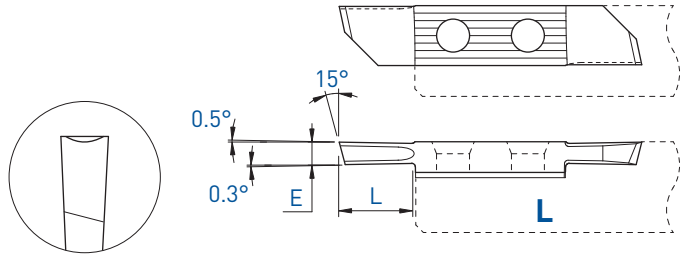

L (R)

Coupe à droite déportée  
Versetztes Rechtsschneiden  
Right cut off line

E	L	Art. N°	TiAIN	TiN	N (µk20)
1.5	7.5	751RU-1.5	■	■	■
2.0	10	751RU-2.0	■	■	■

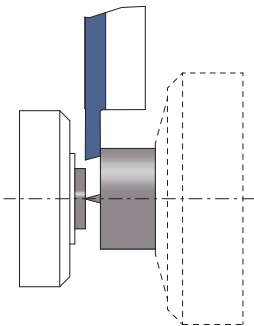

Tronçonnage  
 Abstechen  
 Parting off

Coupe déportée  
 Versetztes Schneiden  
 Cut off line

751RZU

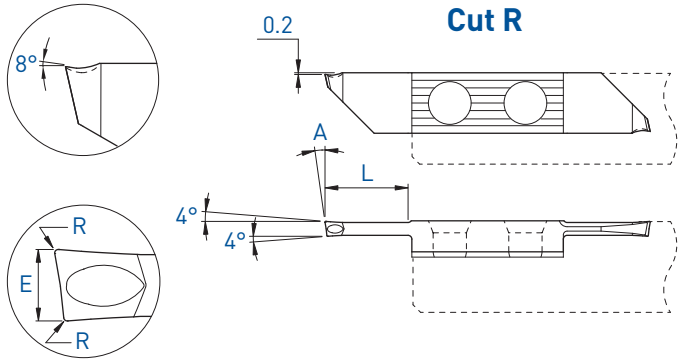

**R (L)**

Coupe à gauche déportée  
 Versetztes Linksschneiden  
 Left cut off line

E	A	L	R	Art. N°	TiAlN	TiN	N (µk20)
2.0	8°	11.0	0.10	751RZU8-2.0-8°-R10	■		

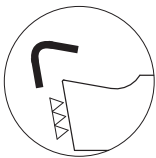

Arête de coupe honée  
 Gehonte Schneidkante  
 Honed edge

f min: 0.02 mm/U

Tronçonnage  
Abstechen  
Parting off

Coupe déportée  
Versetztes Schneiden  
Cut off line

761NXF / 751NXF

Cut L

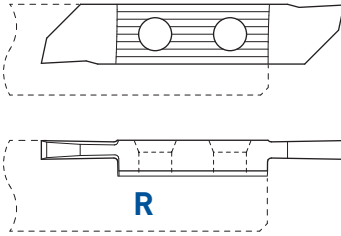

Cut R

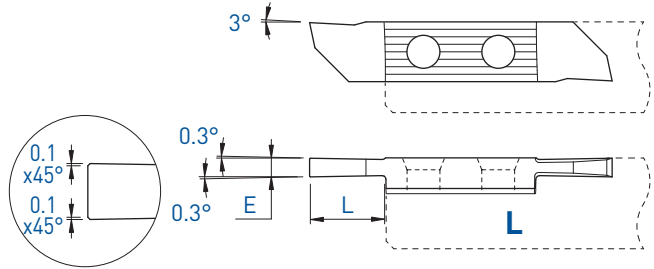

R (L)

Coupe à gauche déportée  
Versetztes Linksschneiden  
Left cut off line

L (R)

Coupe à droite déportée  
Versetztes Rechtsschneiden  
Right cut off line

E	L	Art. N°	TiAlN	TiN	N (µk20)	HTA	HTiN	HN (µk10)	Art. N°	TiAlN	TiN	N (µk20)	HTA	HTiN	HN (µk10)
2.0	10	761NXF-2.0	■	■	■	■	□	■	751NXF-2.0	■	■	■	■	□	■
2.5	10	761NXF-2.5	■	■	■				751NXF-2.5	■	■	■			
3.0	10	761NXF-3.0	■	■	■				751NXF-3.0	■	■	■			

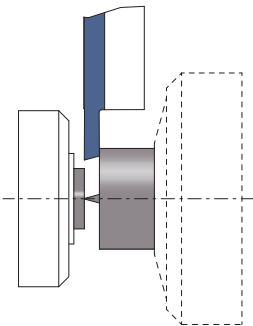

**Tronçonnage**  
**Abstechen**  
**Parting off**

**Coupe déportée**  
**Versetztes Schneiden**  
**Cut off line**

**761LD / 751RD**

**Cut L**

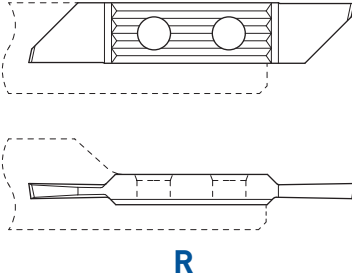

**Cut R**

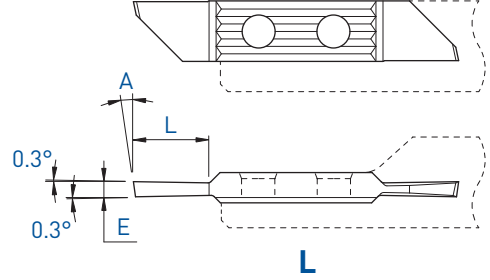

**R (L)**

Coupe à gauche déportée  
 Versetztes Linksschneiden  
 Left cut off line

**L (R)**

Coupe à droite déportée  
 Versetztes Rechtsschneiden  
 Right cut off line

E	A	L	Art. N°	TiAlN	TiN	N (µk20)	HTA	HTiN	HN (µk10)	Art. N°	TiAlN	TiN	N (µk20)	HTA	HTiN	HN (µk10)
1.0	8°	5	761LD-1.0-8°	■	■	■	■	□	■	751RD-1.0-8°	■	■	■	■	□	■
1.0	15°	5	761LD-1.0-15°	■	■	■	■	□	■	751RD-1.0-15°	■	■	■	■	□	■
1.2	8°	5	761LD-1.2-8°	■	■	■				751RD-1.2-8°	■	■	■	■	□	■
1.5	8°	8	761LD-1.5-8°	■	■	■				751RD-1.5-8°	■	■	■	■	■	■
1.5	15°	8	761LD-1.5-15°	■	■	■				751RD-1.5-15°	■	■	■	■	□	■
1.6	8°	8	761LD-1.6-8°	■	■	■				751RD-1.6-8°	■	■	■			
1.8	8°	10	761LD-1.8-8°	■	■	■				751RD-1.8-8°	■	■	■	■	□	■
2.0	8°	10	761LD-2.0-8°	■	■	■				751RD-2.0-8°	■	■	■	■	□	■
2.0	15°	10	761LD-2.0-15°	■	■	■	■	□	■	751RD-2.0-15°	■	■	■	■	□	■
2.5	8°	10	-							751RD-2.5-8°	■	■	■	■	□	■

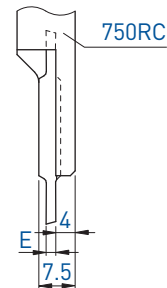
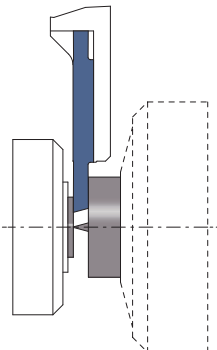

Tronçonnage  
Abstechen  
Parting off

Coupe déportée  
Versetztes Schneiden  
Cut off line

751RAS

Cut R

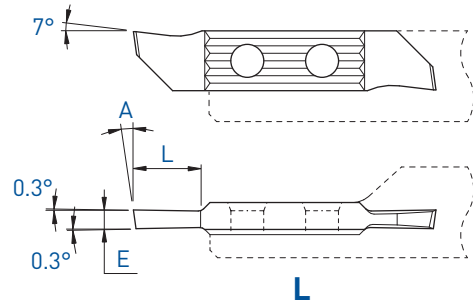

L (R)

Coupe à droite déportée  
Versetztes Rechtsschneiden  
Right cut off line

E	A	L	Art. N°	TiAlN	TiN	N (µk20)	HTA	HTiN	HN (µk10)
1.6	8°	7.5	751RAS-1.6-8°	■	■	■			
1.6	15°	7.5	751RAS-1.6-15°	■	■	■	■	□	■
2.0	8°	9	751RAS-2.0-8°	■	■	■	■	□	■
2.0	15°	9	751RAS-2.0-15°	■	■	■			
2.5	8°	9	751RAS-2.5-8°	■	■	■			
2.5	15°	9	751RAS-2.5-15°	■	■	■			

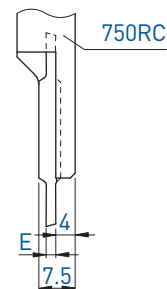
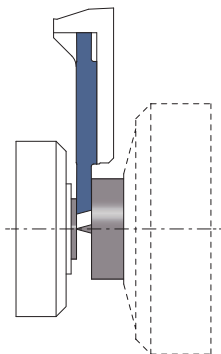

# TOP-LINE

Tournage avant  
Vorwärts drehen  
Front turning

752 / 762

L

R

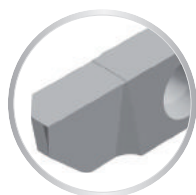
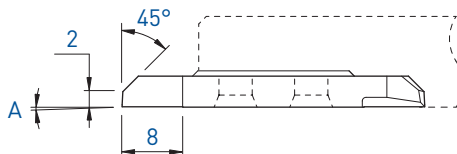
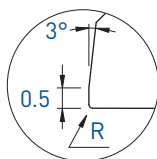
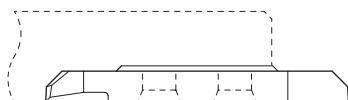
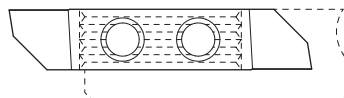
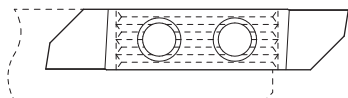

L

R

A	R	Art. N°	TiAlN	TiN	N (µk20)	HTA	HTiN	HN (µk10)	Art. N°	TiAlN	TiN	N (µk20)	HTA	HTiN	HN (µk10)
0°	0	752	■	■	■	■	□	■	762	■	■	■	■	□	■
0°	0.20	-							762-R20	■	■	■	■	□	■
3°	0	752-3°	■	■	■	■	□	■	762-3°	■	■	■	■	□	■

7XX-XX-B



Sur demande pour serrage type B, voir page 1.03  
Wahlweise mit B-Spannsystem, siehe Seite 1.03  
On request for B clamping system, see page 1.03



Tournage avant  
Vorwärts drehen  
Front turning

752PX / 762PX

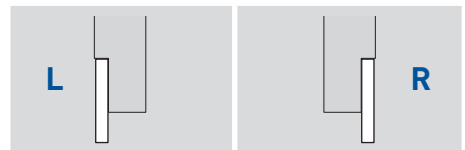
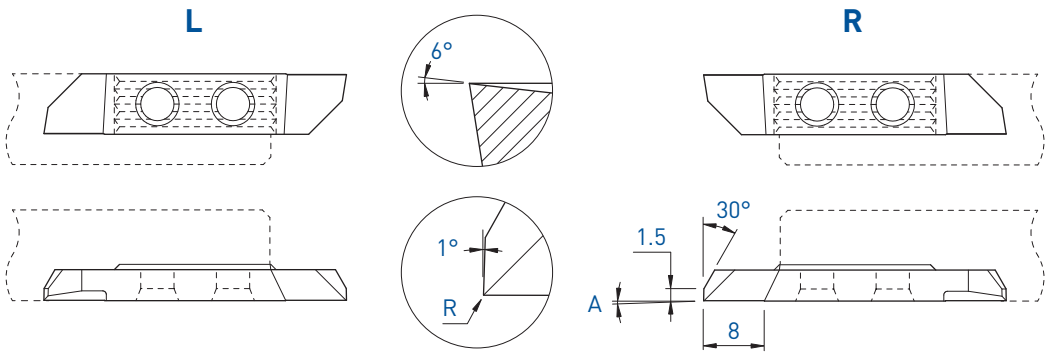

A	R	Art. N°	TiAlN	TiN	N (µk20)	Art. N°	TiAlN	TiN	N (µk20)
0°	0	752PX	■	■	■	762PX	■	■	■

7XX-XX-B



Sur demande pour serrage type B, voir page 1.03  
Wahlweise mit B-Spannsystem, siehe Seite 1.03  
On request for B clamping system, see page 1.03

■ = disponible / verfügbar / available  
□ = selon disponibilité du stock / jenach Lagerverfügbarkeit / depending on stock availability

# TOP-LINE

Tournage avant  
Vorwärts drehen  
Front turning

## 752X / 762X

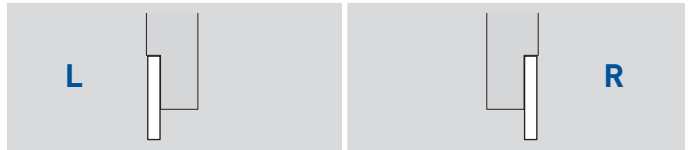
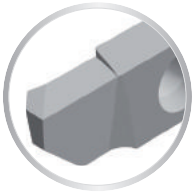
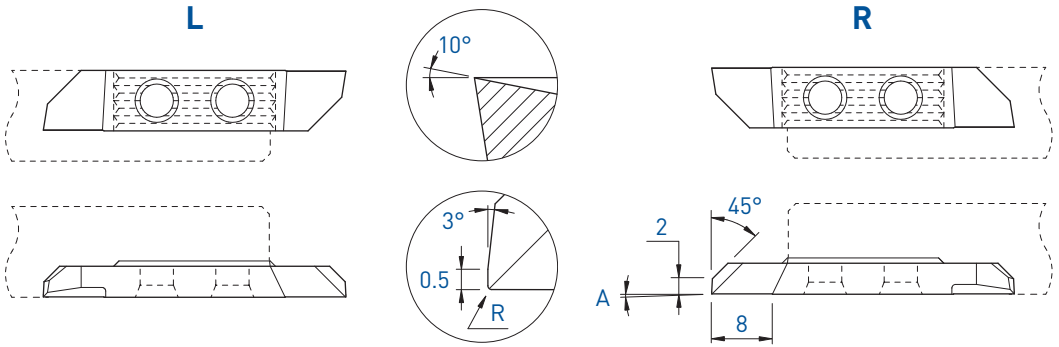

A	R	Art. N°	TiAlN	TiN	N (µk20)	HTA	HTiN	HN (µk10)	Art. N°	TiAlN	TiN	N (µk20)	HTA	HTiN	HN (µk10)
0°	0	752X	■	■	■	■	■	■	762X	■	■	■	■	■	■
0°	0.20	752X-R20	■	■	■				762X-R20	■	■	■	■	■	■

7XX-XX-B

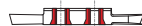

Sur demande pour serrage type B, voir page 1.03  
Wahlweise mit B-Spannsystem, siehe Seite 1.03  
On request for B clamping system, see page 1.03

Tournage avant  
Vorwärts drehen  
Front turning

762VX-800

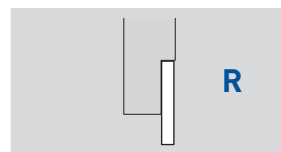
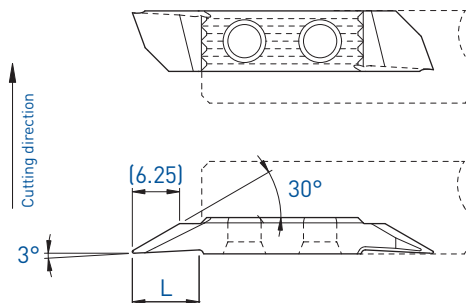
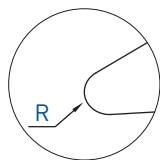
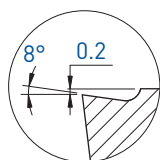

L	R	Art. N°	HTA	HTiN	HN [µk10]
9	0.15	762VX-800-R15	■	■	■

Tournage avant  
Vorwärts drehen  
Front turning

## 762VUX

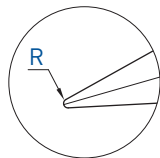
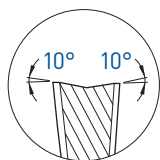

R

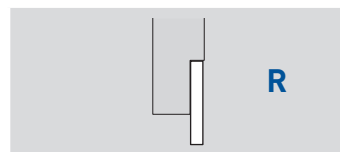
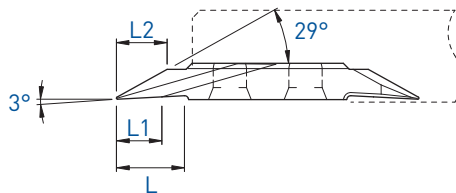
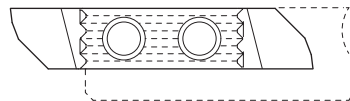

L	L1	L2	R	Art. N°	Ti/AlN N [µk20]	HTA	HN [µk10]
9	6	6.9	0.08	762VUX10-29°-R08	■ ■	■ ■	
9	6	6.7	0.15	762VUX10-29°-R15	■ ■	■ ■	
9	6	6.1	0.35	762VUX10-29°-R35	■ ■	■ ■	
9	6	4.9	0.75	762VUX10-29°-R75	■ ■	■ ■	

Tournage avant  
Vorwärts drehen  
Front turning

762ZX

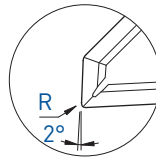
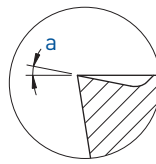

R

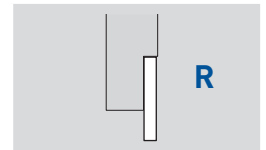
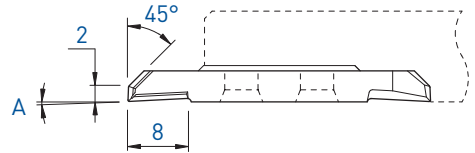
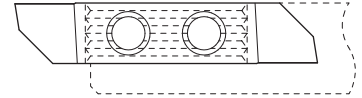

a	A	R	Art. N°	TiAIN	TiN	N (µk20)
10°	3°	0.08	762ZX10-R08	■	□	
	3°	0.20	762ZX10-R20	■	□	

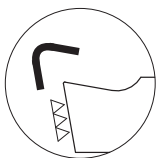

Arête de coupe honée  
Gehonte Schneidkante  
Honed edge

f min: 0.02 mm/U

7XX-XX-B



Sur demande pour serrage type B, voir page 1.03  
Wahlweise mit B-Spannsystem, siehe Seite 1.03  
On request for B clamping system, see page 1.03

# TOP-LINE

Tournage multifonction  
 Mehrzweck Drehen  
 Multifunction turning

752S / 762S  
 753S / 763S

L

R

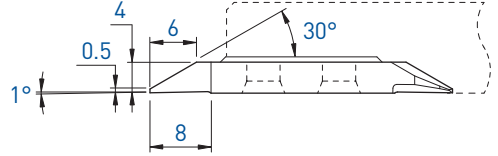
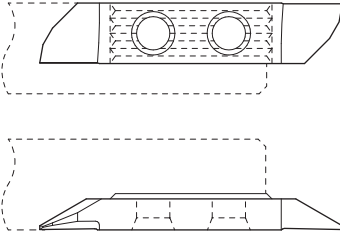

Tournage avant  
 Vorwärts drehen  
 Front turning

L						R								
Art. N°	TiAlN	TiN	N (µk20)	HTA	HTiN	HN (µk10)	Art. N°	TiAlN	TiAlX	TiN	N (µk20)	HTA	HTiN	HN (µk10)
752S05	■	■	■	■	□	■	762S05	■	■	■	■	■	■	■

L

R

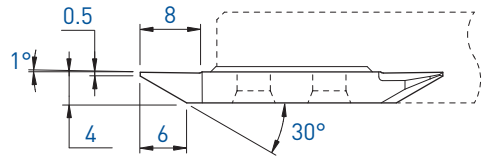
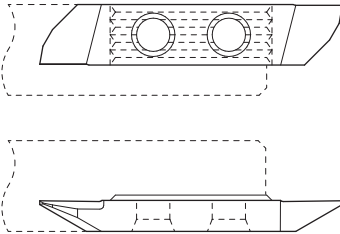

Tournage arrière  
 Rückwärts drehen  
 Back turning

L						R								
Art. N°	TiAlN	TiN	N (µk20)	HTA	HTiN	HN (µk10)	Art. N°	TiAlN	TiAlX	TiN	N (µk20)	HTA	HTiN	HN (µk10)
753S05	■	■	■	■	■	■	763S05	■	■	■	■	■	■	■

Tournage arrière  
 Rückwärts drehen  
 Back turning

753 / 763

L

R

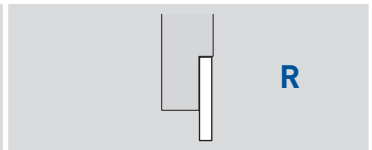
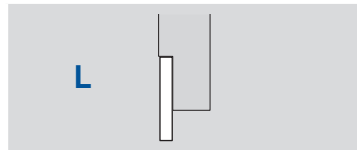
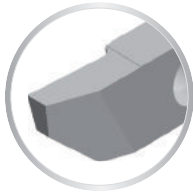
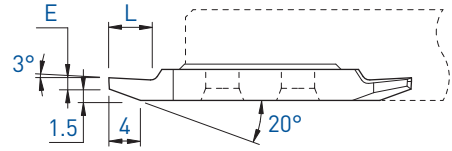
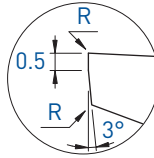
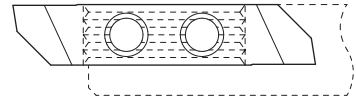
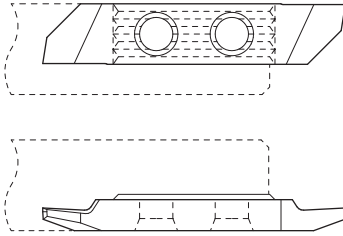

E	L	R	Art. N°	TiAlN			HTA		HN [µk(10)]	Art. N°	TiAlN			HTA		HN [µk(10)]
				TiN	N [µk(20)]	HTA	HTiN	TiN			N [µk(20)]	HTA	HTiN			
1.0	5	0	753-1.0	■	■	■	■	□	■	763-1.0	■	■	■	■	■	■
1.0	5	0.08	753-1.0-R08	■	■	■				763-1.0-R08	■	■	■	■	□	■
1.5	6	0	753-1.5	■	■	■				763-1.5	■	■	■	■	□	■
2.0	7.5	0	753-2.0	■	■	■				763-2.0	■	■	■	■	□	■
2.5	9	0	753-2.5	■	■	■				763-2.5	■	■	■	■	□	■

7XX-XX-B



Sur demande pour serrage type B, voir page 1.03  
 Wahlweise mit B-Spannsystem, siehe Seite 1.03  
 On request for B clamping system, see page 1.03

■ = disponible / verfügbar / available  
 □ = selon disponibilité du stock / jenach Lagerverfügbarkeit / depending on stock availability

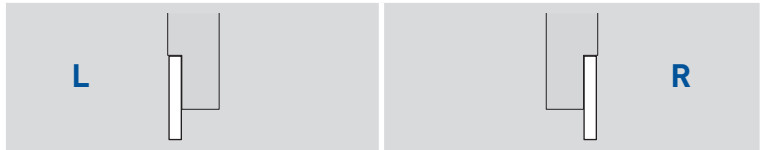
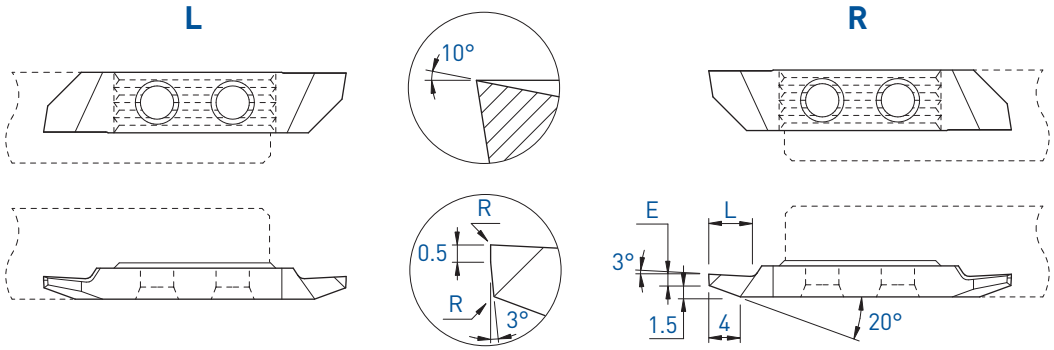

E	L	R	L				R								
			Art. N°	TiAlN	TiN	N (µk20)	HTA	HTiN	HN (µk10)	Art. N°	TiAlN	TiN	N (µk20)	HTA	HTiN
1.0	5	0	753X-1.0	■	■	■			763X-1.0	■	■	■	■	□	■
1.0	5	0.08	753X-1.0-R08	■	■	■	■	□	763X-1.0-R08	■	■	■	■	□	■
1.0	5	0.20	753X-1.0-R20	■	■	■			763X-1.0-R20	■	■	■			
1.5	6	0	753X-1.5	■	■	■			763X-1.5	■	■	■	■	□	■
1.5	6	0.20	753X-1.5-R20	■	■	■			763X-1.5-R20	■	■	■			
2.0	7.5	0	753X-2.0	■	■	■			763X-2.0	■	■	■			
2.0	7.5	0.20	753X-2.0-R20	■	■	■			763X-2.0-R20	■	■	■			
2.5	9	0	753X-2.5	■	■	■			763X-2.5	■	■	■			
2.5	9	0.20	753X-2.5-R20	■	■	■			763X-2.5-R20	■	■	■			

**7XX-XX-B**



Sur demande pour serrage type B, voir page 1.03  
Wahlweise mit B-Spannsystem, siehe Seite 1.03  
On request for B clamping system, see page 1.03



Tournage arrière  
Rückwärts drehen  
Back turning

753XS / 763XS

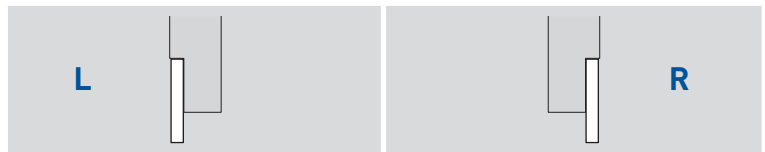
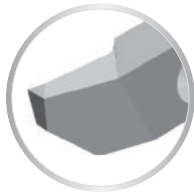
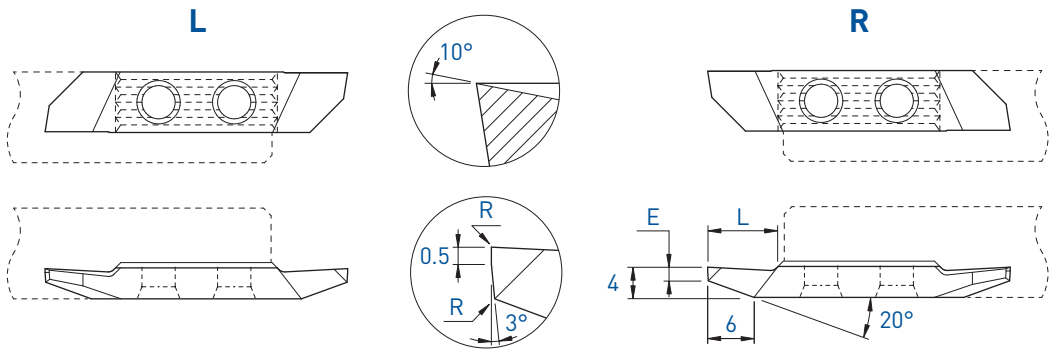

			L				R									
E	L	R	Art. N°	TiAlN	TiN	N (µk20)	HTA	HTiN	HN (µk10)	Art. N°	TiAlN	TiN	N (µk20)	HTA	HTiN	HN (µk10)
1.8	9	0	753XS-1.8	■	■	■				763XS-1.8	■	■	■	■	□	■
1.8	9	0.20	753XS-1.8-R20	■	■	■				763XS-1.8-R20	■	■	■			

7XX-XX-B

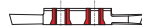

Sur demande pour serrage type B, voir page 1.03  
Wahlweise mit B-Spannsystem, siehe Seite 1.03  
On request for B clamping system, see page 1.03

■ = disponible / verfügbar / available  
□ = selon disponibilité du stock / jenach Lagerverfügbarkeit / depending on stock availability

# TOP-LINE

Tournage arrière  
Rückwärts drehen  
Back turning

## 753VX-8° / 763VX-8°

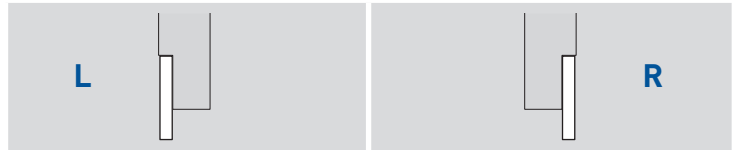
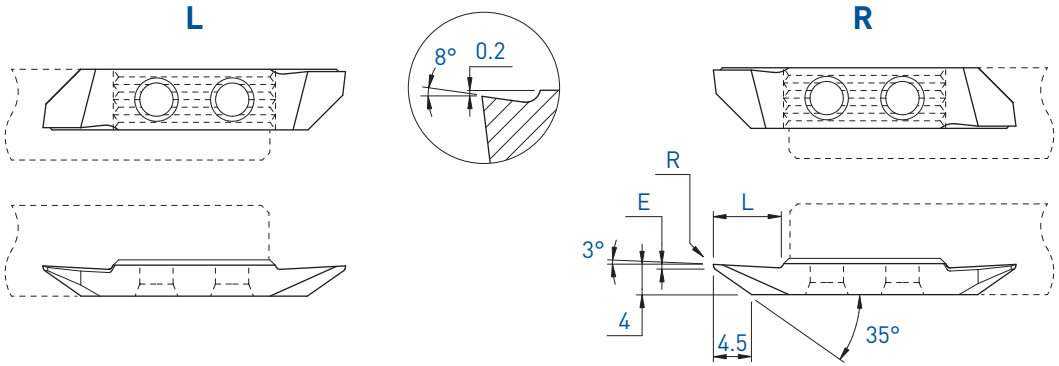

			L					R								
E	L	R	Art. N°	TiAlN	TiN	N (µk20)	HTA	HTiN	HN (µk10)	Art. N°	TiAlN	TiN	N (µk20)	HTA	HTiN	HN (µk10)
1.0	9	0	753VX-8°	■	■	■				763VX-8°	■	■	■	■	■	■
1.0	9	0.08	753VX-8°-R08	■	■	■				763VX-8°-R08	■	■	■	■	□	■
1.0	9	0.20	-							763VX-8°-R20	■	■	■			

7XX-XX-B

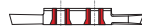

Sur demande pour serrage type B, voir page 1.03  
Wahlweise mit B-Spannsystem, siehe Seite 1.03  
On request for B clamping system, see page 1.03

Tournage arrière  
Rückwärts drehen  
Back turning

753VX-805 / 763VX-805

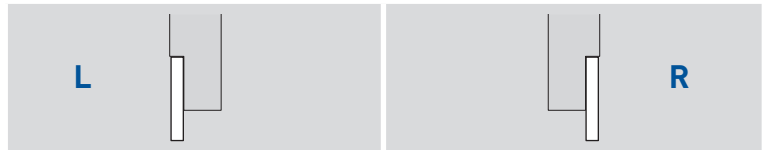
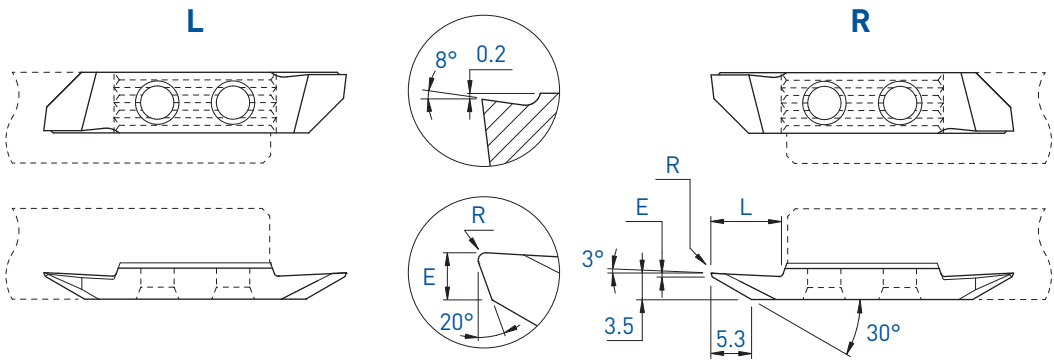

E	L	R	Art. N°	TiAlN	TiN	N (µk20)	HTA	HTiN	HN (µk10)	Art. N°	TiAlN	TiN	N (µk20)	HTA	HTiN	HN (µk10)
0.5	9	0.08	753VX-805-R08	■	■	■	■	□	■	763VX-805-R08	■	■	■	■	□	■

7XX-XX-B

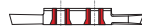

Sur demande pour serrage type B, voir page 1.03  
Wahlweise mit B-Spannsystem, siehe Seite 1.03  
On request for B clamping system, see page 1.03

■ = disponible / verfügbar / available  
□ = selon disponibilité du stock / jenach Lagerverfügbarkeit / depending on stock availability

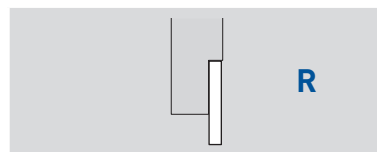
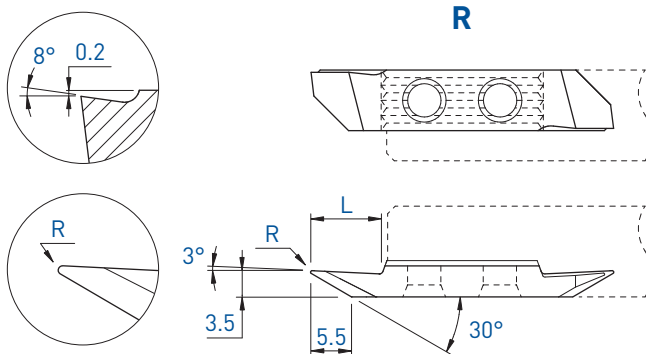

L	R	Art. N°	TiAlN	TiN	N (μk20)	HTA	HTiN	HN (μk10)
9	0.08	763VX-800-R08	■	■	■	■	□	■
9	0.20	763VX-800-R20	■	■	■	■	□	■

7XX-XX-B



Sur demande pour serrage type B, voir page 1.03  
Wahlweise mit B-Spannsystem, siehe Seite 1.03  
On request for B clamping system, see page 1.03

Tournage arrière  
 Rückwärts drehen  
 Back turning

753VX-15° / 763VX-15°

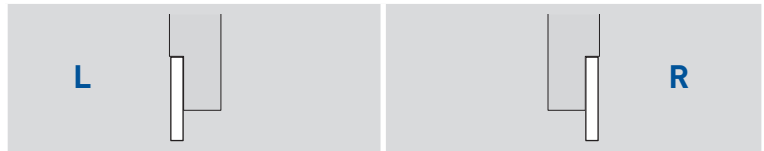
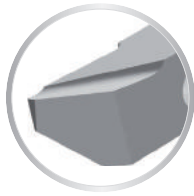
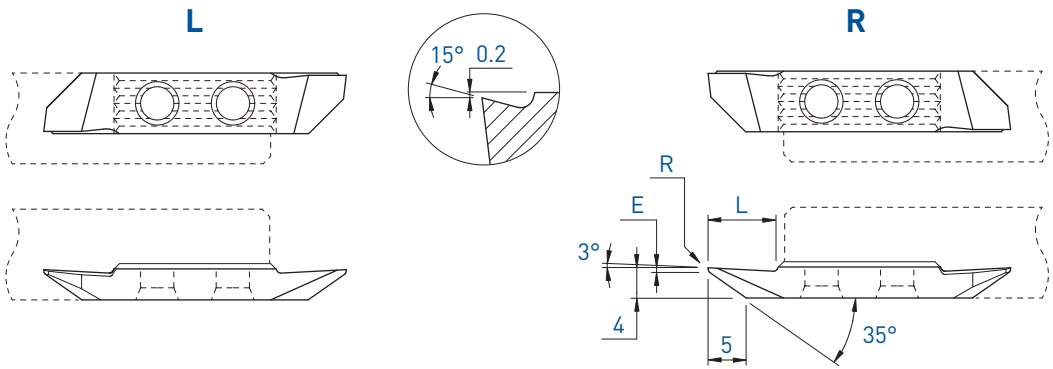

			L				R									
E	L	R	Art. N°	TiAlN	TiN	N (µk20)	HTA	HTiN	HN (µk10)	Art. N°	TiAlN	TiN	N (µk20)	HTA	HTiN	HN (µk10)
0.6	9	0	753VX-15°	■	■	■				763VX-15°	■	■	■	■	□	■
0.6	9	0.08	753VX-15°-R08	■	■	■				763VX-15°-R08	■	■	■	■	□	■

7XX-XX-B



Sur demande pour serrage type B, voir page 1.03  
 Wahlweise mit B-Spannsystem, siehe Seite 1.03  
 On request for B clamping system, see page 1.03

■ = disponible / verfügbar / available  
 □ = selon disponibilité du stock / jenach Lagerverfügbarkeit / depending on stock availability

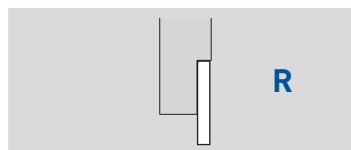
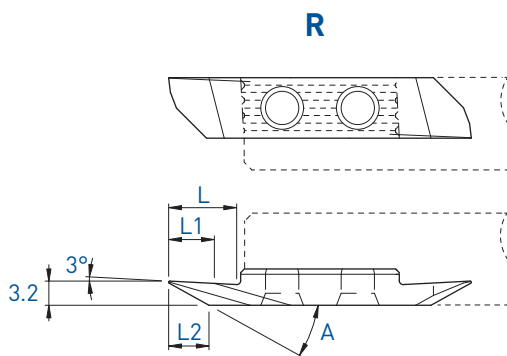
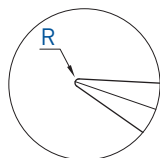
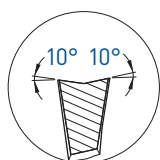

L	L1	L2	A	R	Art. N°	TiAlN N [µk20]	HTA	HN [µk10]
9	6	5.5	29	0.08	763VUX10-29°-R08	■	■	■
9	6	5.3	29	0.15	763VUX10-29°-R15	■	■	■
9	6	4.7	29	0.35	763VUX10-29°-R35	■	■	■
9	6	3.6	29	0.75	763VUX10-29°-R75	■	■	■
9	6	4.2	35	0.15	763VUX10-35°-R15	■	■	■
9	6	3.8	35	0.35	763VUX10-35°-R35	■	■	■

7XX-XX-B



Sur demande pour serrage type B, voir page 1.03  
Wahlweise mit B-Spannsystem, siehe Seite 1.03  
On request for B clamping system, see page 1.03

Tournage arrière  
Rückwärts drehen  
Back turning

753ZX / 763ZX

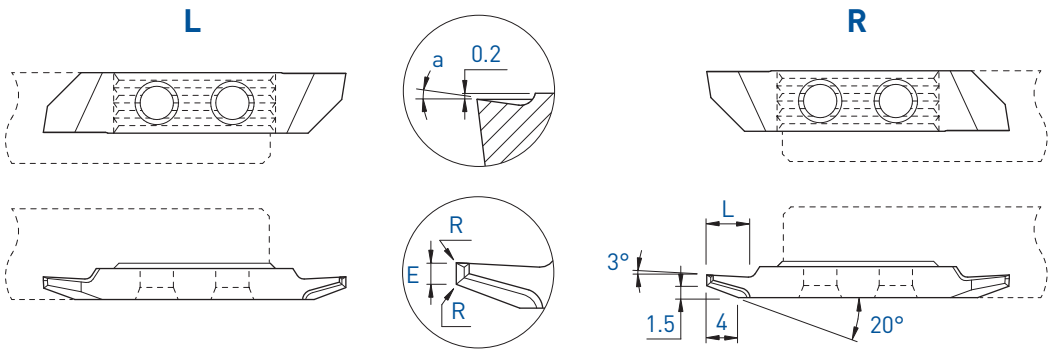

Pour un meilleur contrôle des copeaux  
Für eine bessere Spankontrolle  
For a better chip-control

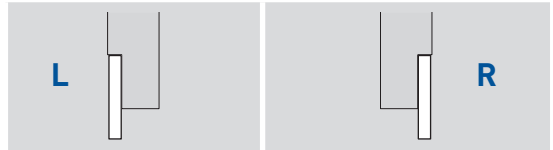

a	E	L	R	Art. N°	TiAIN	TiN	N (µk20)	Art. N°	TiAIN	TiN	N (µk20)
10°	1.0	5	0.01	753ZX10-1.0	■	□		763ZX10-1.0	■	■	
	1.0	5	0.08	-				763ZX10-1.0-R08	■	■	
	1.0	5	0.20	-				763ZX10-1.0-R20	■	■	



Arête de coupe honée  
Gehonte Schneidkante  
Honed edge

f min: 0.02 mm/U



7XX-XX-B

Sur demande pour serrage type B, voir page 1.03  
Wahlweise mit B-Spannsystem, siehe Seite 1.03  
On request for B clamping system, see page 1.03

# TOP-LINE

Tournage arrière / pré-coupe  
 Rückwärts drehen / vorstechen  
 Back turning / pre-parting off

## 753P / 763P

L

R

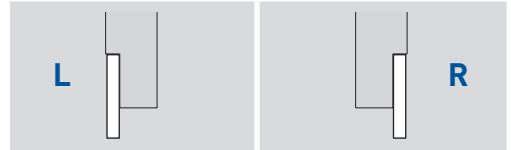
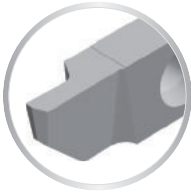
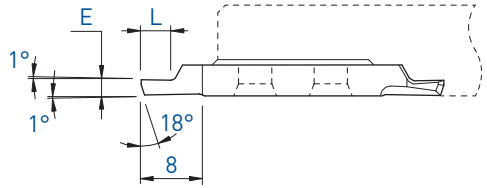
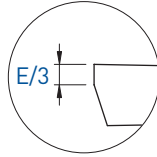
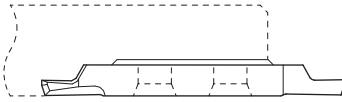
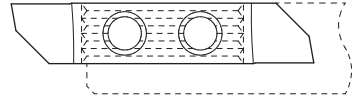
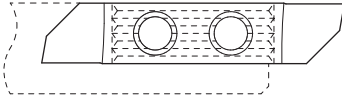

E	L	Art. N°	TiAlN	TiN	N (µk20)	Art. N°	TiAlN	TiN	N (µk20)
1.5	3	753P-1.5	■	■	■	763P-1.5	■	■	■
1.8	3.5	753P-1.8	■	■	■	763P-1.8	■	■	■
2.0	4	753P-2.0	■	■	■	763P-2.0	■	■	■
2.2	5	753P-2.2	■	■	■	763P-2.2	■	■	■
2.5	6	753P-2.5	■	■	■	763P-2.5	■	■	■
3.0	6	753P-3.0	■	■	■	763P-3.0	■	■	■

7XX-XX-B



Sur demande pour serrage type B, voir page 1.03  
 Wahlweise mit B-Spannsystem, siehe Seite 1.03  
 On request for B clamping system, see page 1.03



Fonçage-tournage

Einstecken und drehen

Grooving and turning

754 / 764

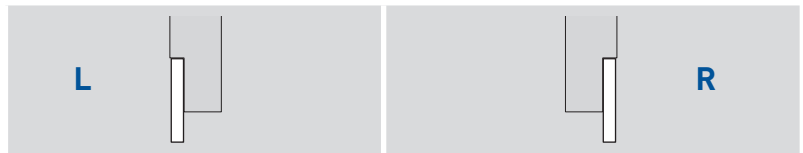
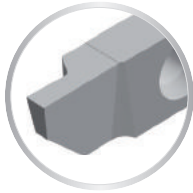
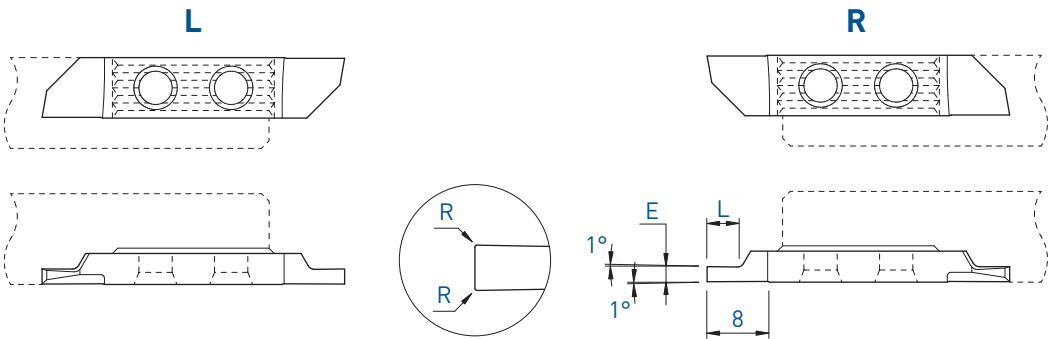

E	L	R	Art. N°	TiAlN	TiN	N (µk20)	HTA	HTiN	HN (µk10)	Art. N°	TiAlN	TiAlX	TiN	N (µk20)	HTA	HTiN	HN (µk10)
0.5	1.5	0	754-0.5	■	■	■				764-0.5	■	■	■	■	■	■	■
0.75	2	0	754-0.75	■	■	■				764-0.75	■	■	■	■	■	■	■
0.8	2	0	-							764-0.8	■	■	■	■	■	□	■
0.95	3	0	754-0.95	■	■	■	■	□	■	764-0.95	■	■	■	■	■	■	■
1.0	2.5	0	754-1.0	■	■	■	■	□	■	764-1.0	■	■	■	■	■	■	■
1.0	2.5	0.08	754-1.0-R08	■	■	■	■	□	■	764-1.0-R08	■	■	■	■	■	□	■
1.2	3	0	754-1.2	■	■	■	■			764-1.2	■	■	■	■	■	□	■
1.5	3	0	754-1.5	■	■	■	■	□	■	764-1.5	■	■	■	■	■	■	■
1.5	3	0.08	754-1.5-R08	■	■	■	■	□	■	764-1.5-R08	■	■	■	■	■	□	■
1.5	3	0.15	-							764-1.5-R15	■	■	□	■	■	■	■
1.5	3	0.20	-							764-1.5-R20	■	■	■	■	■	□	■
1.8	4	0	754-1.8	■	■	■	■			764-1.8	■	■	■	■	■	■	■
2.0	4	0	754-2.0	■	■	■	■	□	■	764-2.0	■	■	■	■	■	■	■
2.0	4	0.08	754-2.0-R08	■	■	■	■	□	■	764-2.0-R08	■	■	■	■	■	□	■
2.0	4	0.15	-							764-2.0-R15	■	■	□	■	■	■	■
2.0	4	0.20	754-2.0-R20	■	■	■	■			764-2.0-R20	■	■	■	■	■	■	■
2.5	6	0	754-2.5	■	■	■	■			764-2.5	■	■	■	■	■	□	■
2.5	6	0.15	-							764-2.5-R15	■	■	□	■	■	■	■
2.5	6	0.20	-							764-2.5-R20	■	■	■	■	■	□	■
3.0	6	0	754-3.0	■	■	■	■	□	■	764-3.0	■	■	■	■	■	□	■
3.0	6	0.08	754-3.0-R08	■	■	■	■			764-3.0-R08	■	■	■	■	■	□	■
3.0	6	0.15	-							764-3.0-R15	■	■	□	■	■	■	■
3.0	6	0.20	754-3.0-R20	■	■	■	■	□	■	764-3.0-R20	■	■	■	■	■	■	■
4.0	8	0	754-4.0	■	■	■	■	■	■	764-4.0	■	■	■	■	■	□	■

7XX-XX-B



Sur demande pour serrage type B, voir page 1.03  
Wahlweise mit B-Spannsystem, siehe Seite 1.03  
On request for B clamping system, see page 1.03

■ = disponible / verfügbar / available  
□ = selon disponibilité du stock / jenach Lagerverfügbarkeit / depending on stock availability

# TOP-LINE

Fonçage-tournage  
 Einstechen und drehen  
 Grooving and turning

## 754VS / 764VS

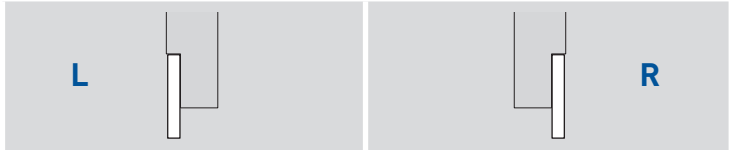
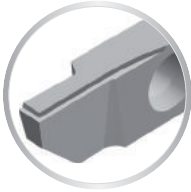
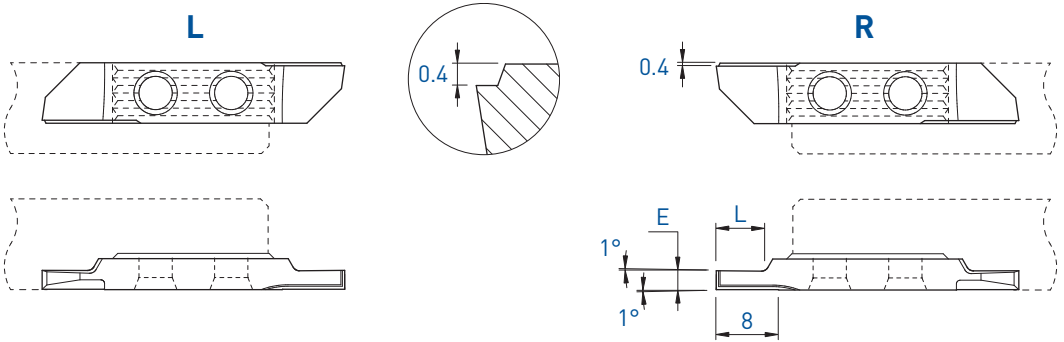

E	L	Art. N°	TiAlN			HTA	HTiN	HN (µk10)	Art. N°	TiAlN			HTA	HTiN	HN (µk10)
			TiN	N (µk20)						TiN	N (µk20)				
1.0	2	754VS-1.0	■	■	■				764VS-1.0	■	■	■			
1.2	2.5	754VS-1.2	■	■	■	■	□	■	764VS-1.2	■	■	■			
1.5	3	754VS-1.5	■	■	■				764VS-1.5	■	■	■			
2.0	4	754VS-2.0	■	■	■				764VS-2.0	■	■	■			
2.5	6	754VS-2.5	■	■	■				764VS-2.5	■	■	■	■	□	■
3.0	6	754VS-3.0	■	■	■				764VS-3.0	■	■	■			

7XX-XX-B



Sur demande pour serrage type B, voir page 1.03  
 Wahlweise mit B-Spannsystem, siehe Seite 1.03  
 On request for B clamping system, see page 1.03

Fonçage-tournage

Einstecken und drehen

Grooving and turning

754X / 764X

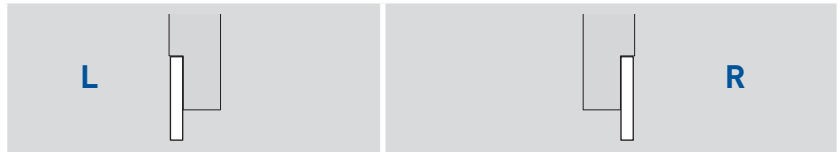
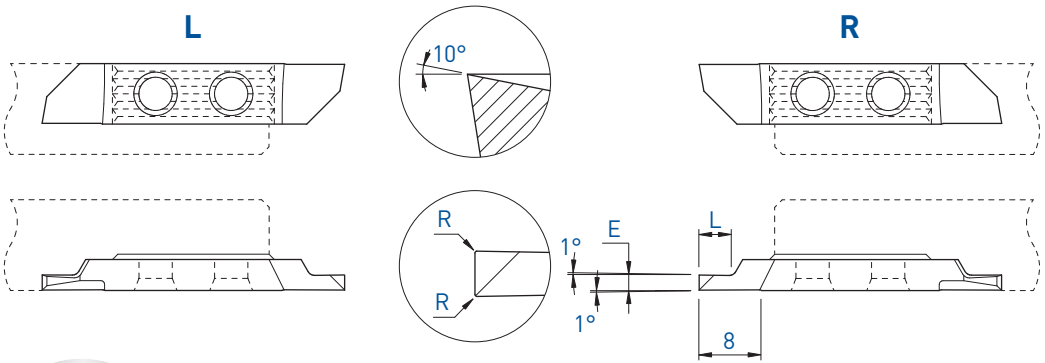

E	L	R	Art. N°	TiAlN	TiN	N (µk20)	HTA	HTiN	HN (µk10)	Art. N°	TiAlN	TiAlX	LoX	TiN	N (µk20)	HTA	HTiN	HN (µk10)
1.0	2.5	0	754X-1.0	■	■	■	■	■	■	764X-1.0	■	■	■	■	■	■	■	■
1.0	2.5	0.08	754X-1.0-R08	■	■	■	■	□	■	764X-1.0-R08	■	■	■	■	■	■	□	■
1.0	2.5	0.20	-							764X-1.0-R20	■	■	■	■	■			
1.2	3	0	754X-1.2	■	■	■				764X-1.2	■	■	■	■	■		□	■
1.2	3	0.08	-							764X-1.2-R08	■	■	■	■	■			
1.5	3	0	754X-1.5	■	■	■		□	■	764X-1.5	■	■	■	■	■		■	■
1.5	3	0.08	754X-1.5-R08	■	■	■		□	■	764X-1.5-R08	■	■	■	■	■		□	■
1.5	3	0.15	-							764X-1.5-R15	■	■	■	□	■		■	■
1.5	3	0.20	754X-1.5-R20	■	■	■				764X-1.5-R20	■	■	■	■	■		■	■
1.8	4	0	754X-1.8	■	■	■				764X-1.8	■	■	■	■	■		□	■
1.8	4	0.20	-							764X-1.8-R20	■	■	■	■	■			
2.0	4	0	754X-2.0	■	■	■		□	■	764X-2.0	■	■	■	■	■		■	■
2.0	4	0.08	754X-2.0-R08	■	■	■		□	■	764X-2.0-R08	■	■	■	■	■		□	■
2.0	4	0.15	-							764X-2.0-R15	■	■	■	□	■		■	■
2.0	4	0.20	754X-2.0-R20	■	■	■		□	■	764X-2.0-R20	■	■	■	■	■		□	■
2.0	4	0.35	-							764X-2.0-R35	■	■	■	□	■		■	■
2.5	6	0	754X-2.5	■	■	■		■	■	764X-2.5	■	■	■	■	■		■	■
2.5	6	0.15	-							764X-2.5-R15	■	■	■	□	■		■	■
2.5	6	0.20	754X-2.5-R20	■	■	■		□	■	764X-2.5-R20	■	■	■	■	■		□	■
2.5	6	0.35	-							764X-2.5-R35	■	■	■	□	■		■	■
3.0	6	0	754X-3.0	■	■	■				764X-3.0	■	■	■	■	■		□	■
3.0	6	0.08	754X-3.0-R08	■	■	■				764X-3.0-R08	■	■	■	■	■		□	■
3.0	6	0.15	-							764X-3.0-R15	■	■	■	□	■		■	■
3.0	6	0.20	754X-3.0-R20	■	■	■				764X-3.0-R20	■	■	■	■	■		□	■
3.0	6	0.35	-							764X-3.0-R35	■	■	■	□	■		■	■
4.0	8	0	754X-4.0	■	■	■				764X-4.0	■	■	■	■	■		□	■
4.0	8	0.20	754X-4.0-R20	■	■	■				764X-4.0-R20	■	■	■	■	■		□	■
4.0	8	0.35	-							764X-4.0-R35	■	■	■	□	■		■	■

■ = disponible / verfügbar / available  
 □ = selon disponibilité du stock / jenach Lagerverfügbarkeit / depending on stock availability



7XX-XX-B Sur demande pour serrage type B, voir page 1.03  
 Wahlweise mit B-Spannsystem, siehe Seite 1.03  
 On request for B clamping system, see page 1.03

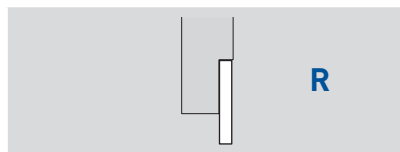
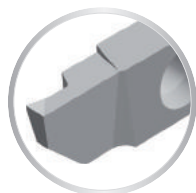
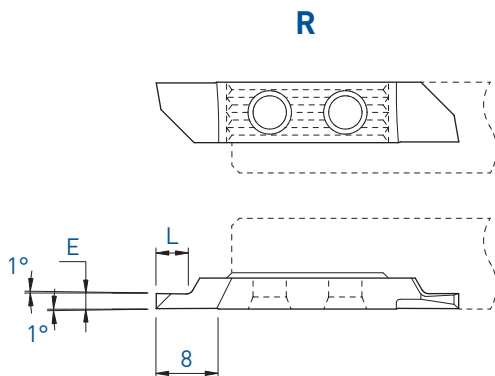
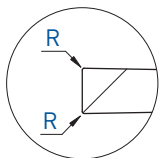
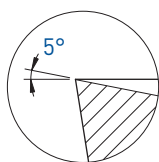

E	L	R	Art. N°	TiAIN	TiAlX	LOX	TiN	N (µm20)
1.5	3	0.08	764X5-1.5-R08-EP	■	■	■	■	■
2.0	4	0.08	764X5-2.0-R08-EP	■	■	■	■	■
2.5	6	0.08	764X5-2.5-R08-EP	■	■	■	■	■
2.5	6	0.15	764X5-2.5-R15-EP	■	■	■	■	■
3.0	6	0.08	764X5-3.0-R08-EP	■	■	■	■	■
3.0	6	0.15	764X5-3.0-R15-EP	■	■	■	■	■
4.0	8	0.15	764X5-4.0-R15-EP	■	■	■	■	■
4.0	8	0.35	764X5-4.0-R35-EP	■	■	■	■	■

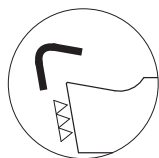

Arête de coupe honée  
Gehonte Schneidkante  
Honed edge

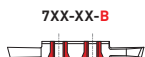

Sur demande pour serrage type B, voir page 1.03  
Wahlweise mit B-Spannsystem, siehe Seite 1.03  
On request for B clamping system, see page 1.03

Fonçage-tournage

Einstecken und drehen

Grooving and turning

764X10-EP

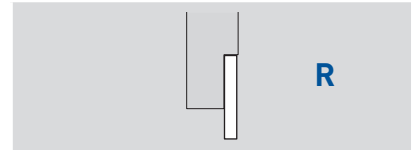
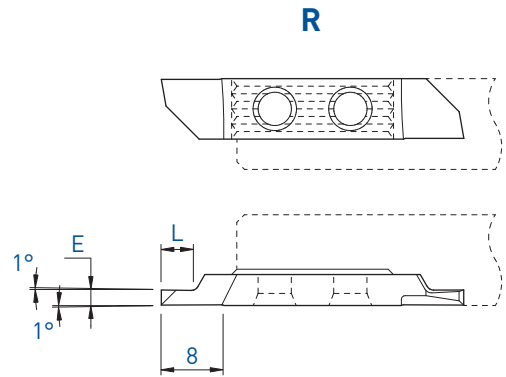
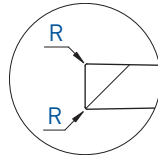
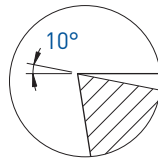

E	L	R	Art. N°	TiAIN	TiAlX	LoX	TiN	N (µm20)
1.5	3	0.08	764X10-1.5-R08-EP	■	■	■	■	■
2.0	4	0.08	764X10-2.0-R08-EP	■	■	■	■	■
2.5	6	0.08	764X10-2.5-R08-EP	■	■	■	■	■
2.5	6	0.15	764X10-2.5-R15-EP	■	■	■	■	■
3.0	6	0.08	764X10-3.0-R08-EP	■	■	■	■	■
3.0	6	0.15	764X10-3.0-R15-EP	■	■	■	■	■
4.0	8	0.15	764X10-4.0-R15-EP	■	■	■	■	■
4.0	8	0.35	764X10-4.0-R35-EP	■	■	■	■	■

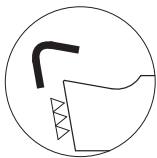

Arête de coupe honée  
Gehonte Schneidkante  
Honed edge



7XX-XX-B  
Sur demande pour serrage type B, voir page 1.03  
Wahlweise mit B-Spannsystem, siehe Seite 1.03  
On request for B clamping system, see page 1.03

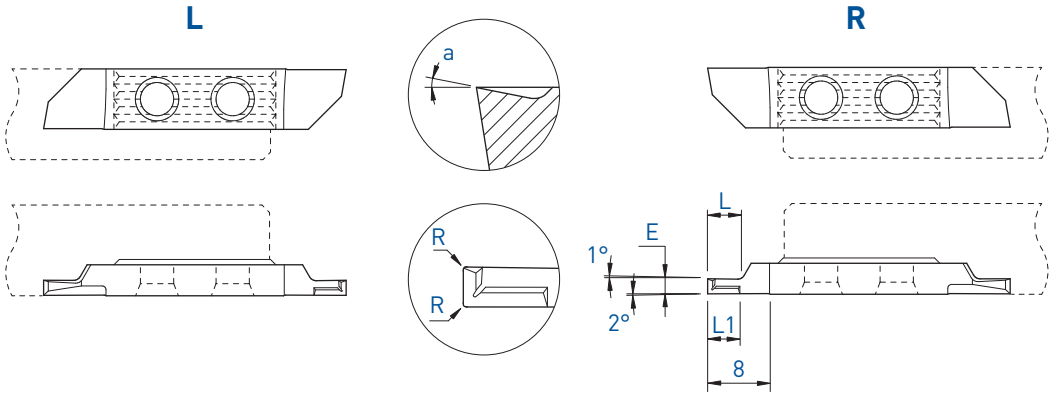

Pour un meilleur contrôle des copeaux  
Für eine bessere Spankontrolle  
For a better chip-control



a	E	L	L1	R	Art. N°	TiAlN				Art. N°	TiAlN					
						Ti	Al	N	HN (µk10)		Ti	Al	N	HN (µk10)		
10°	1.5	4	4	0.03	754ZX10-1.5-R03	■	□			764ZX10-1.5-R03	■	■	■			
	1.5	4	4	0.08	754ZX10-1.5-R08	■	□			764ZX10-1.5-R08	■	■	■			
	2.0	4	4	0.08	754ZX10-2.0-R08	■	□			764ZX10-2.0-R08	■	■	■			
	2.0	4	4	0.20	-					764ZX10-2.0-R20	■	■	□			
	2.5	5	5	0.08	754ZX10-2.5-R08	■	■			764ZX10-2.5-R08	■	■	■			
	2.5	5	5	0.20	-					764ZX10-2.5-R20	■	■	■			
	3.0	6	6	0.08	754ZX10-3.0-R08	■	□			764ZX10-3.0-R08	■	■	■			
	3.0	6	6	0.20	-					764ZX10-3.0-R20	■	■	■			
25°	4.0	6	6	0.20	-					764ZX10-4.0-R20	■	■	□			
	2.0	4	4	0.08	-					764ZX25-2.0-R08				■	■	□
	2.0	4	4	0.20	-					764ZX25-2.0-R20				■	■	□
	2.5	5	5	0.08	-					764ZX25-2.5-R08				■	■	□
2.5	5	5	0.20	-					764ZX25-2.5-R20				■	■	□	

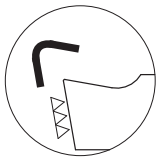

Arête de coupe honée  
Gehonte Schneidkante  
Honed edge

f min: 0.02 mm/U



7XX-XX-B

Sur demande pour serrage type B, voir page 1.03  
Wahlweise mit B-Spannsystem, siehe Seite 1.03  
On request for B clamping system, see page 1.03

Fonçage-tournage

Einstechen und drehen

Grooving and turning

764ZXB

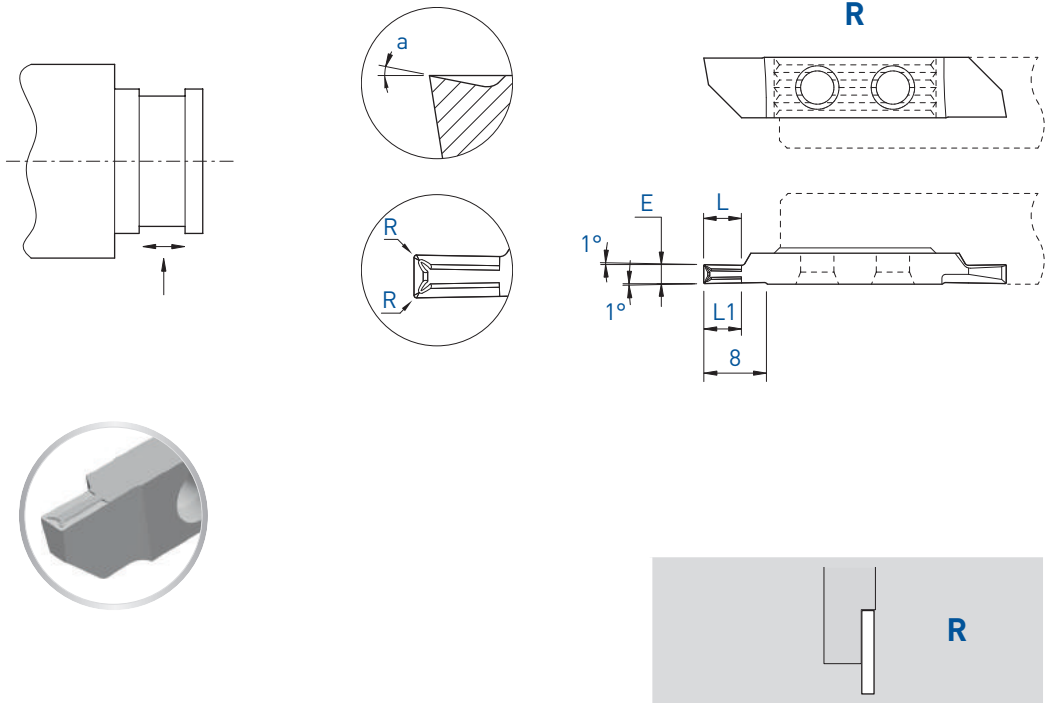

a	E	L	L1	R	Art. N°	TiAIN	TiAlX	LoX	TiN	N (µm20)
10°	1.5	4	4	0.08	764ZXB10-1.5-R08	■	■	■	□	
	2.0	4	4	0.08	764ZXB10-2.0-R08	■	■	■	□	
	2.0	4	4	0.15	764ZXB10-2.0-R15	■	■	■	□	
	2.0	4	4	0.35	764ZXB10-2.0-R35	■	■	■	□	
	2.5	5	5	0.08	764ZXB10-2.5-R08	■	■	■	□	
	2.5	5	5	0.15	764ZXB10-2.5-R15	■	■	■	□	
	2.5	5	5	0.35	764ZXB10-2.5-R35	■	■	■	□	
	3.0	6	6	0.08	764ZXB10-3.0-R08	■	■	■	□	
	3.0	6	6	0.15	764ZXB10-3.0-R15	■	■	■	□	
3.0	6	6	0.35	764ZXB10-3.0-R35	■	■	■	□		

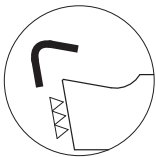

Arête de coupe honée  
Gehonte Schneidkante  
Honed edge

f min: 0.02 mm/U



Sur demande pour serrage type B, voir page 1.03  
Wahlweise mit B-Spannsystem, siehe Seite 1.03  
On request for B clamping system, see page 1.03

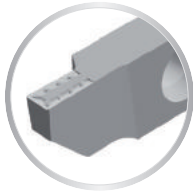
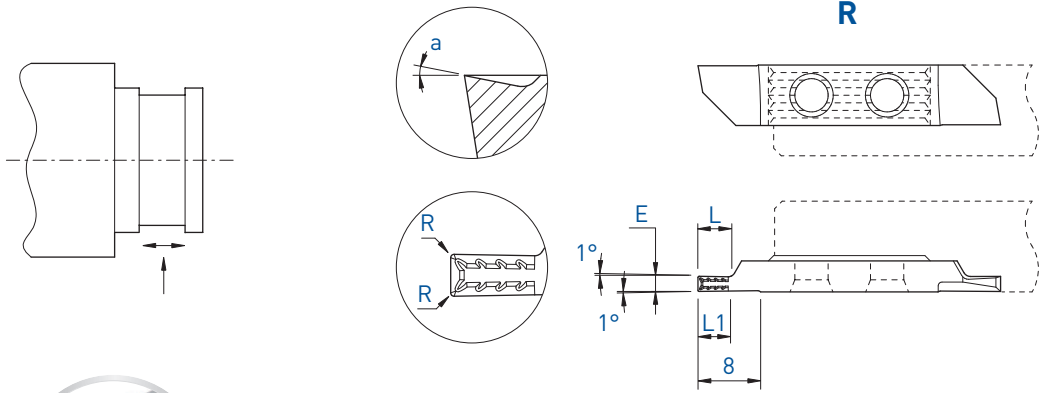

Pour un meilleur contrôle des copeaux  
Für eine bessere Spankontrolle  
For a better chip-control

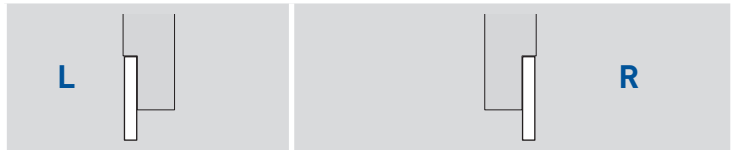

a	E	L	L1	R	Art. N°	L			R				HTA	HN (µk10)	
						TiAlN	TiN	N (µk20)	TiAlN	TiAlX	LOX	TiN			N (µk20)
10°	1.5	4	4	0.03	-				764ZXT10-1.5-R03	■	■	■	□		
	1.5	4	4	0.08	754ZXT10-1.5-R08	■	□		764ZXT10-1.5-R08	■	■	■	□		
	1.5	4	4	0.20	754ZXT10-1.5-R20	■			-						
	2.0	4	4	0.08	754ZXT10-2.0-R08	■	□		764ZXT10-2.0-R08	■	■	■	□		
	2.0	4	4	0.20	754ZXT10-2.0-R20	■			764ZXT10-2.0-R20	■	■	■	□		
	2.0	4	4	0.40	-				764ZXT10-2.0-R40	■	■	■			
	2.5	5	5	0.08	754ZXT10-2.5-R08	■	□		764ZXT10-2.5-R08	■	■	■	□		
	2.5	5	5	0.20	754ZXT10-2.5-R20	■			764ZXT10-2.5-R20	■	■	■	□		
	2.5	5	5	0.40	-				764ZXT10-2.5-R40	■	■	■			
	3.0	6	6	0.08	754ZXT10-3.0-R08	■	□		764ZXT10-3.0-R08	■	■	■	□		
	3.0	6	6	0.20	-				764ZXT10-3.0-R20	■	■	■	□	■	
	3.0	6	6	0.40	-				764ZXT10-3.0-R40	■	■	■	□		
	4.0	8	8	0.20	-				764ZXT10-4.0-R20	■	■	■	□		
	4.0	8	8	0.40	-				764ZXT10-4.0-R40	■	■	■	□		
4.0	8	8	0.80	-				764ZXT10-4.0-R80	■	■	■				

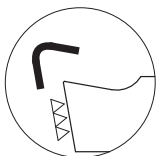

Arête de coupe honée  
Gehonte Schneidkante  
Honed edge

f min: 0.02 mm/U



7XX-XX-B

Sur demande pour serrage type B, voir page 1.03  
Wahlweise mit B-Spannsystem, siehe Seite 1.03  
On request for B clamping system, see page 1.03



Filetage

Gewinde drehen

Threading

756 / 766

L

R

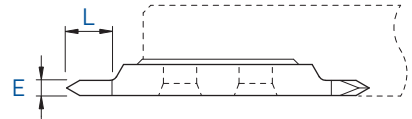
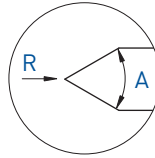
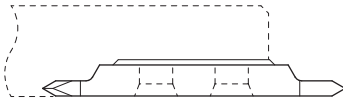
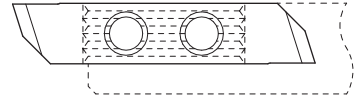
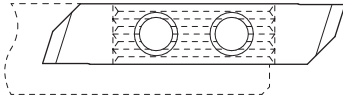

L



R



A	E	L	R	Art. N°	TiAlN	TiN	N (µk20)	HTA	HTiN	HN (µk10)	Art. N°	TiAlN	TiN	N (µk20)	HTA	HTiN	HN (µk10)
60°	2.0	6	-	756-60-2.0	■	■	■				766-60-2.0	■	■	■			
60°	2.0	6	0.02	756-60-2.0-R02	■	■	■	■	□	■	766-60-2.0-R02	■	■	■	■	□	■
60°	3.0	8	-	756-60-3.0	■	■	■				766-60-3.0	■	■	■			
60°	3.0	8	0.02	756-60-3.0-R02	■	■	■	■	□	■	766-60-3.0-R02	■	■	■	■	□	■
55°	2.0	6	-	756-55-2.0	■	■	■				766-55-2.0	■	■	■			
55°	2.0	6	0.02	756-55-2.0-R02	■	■	■				766-55-2.0-R02	■	■	■			
55°	3.0	8	-	756-55-3.0	■	■	■				766-55-3.0	■	■	■			
55°	3.0	8	0.02	756-55-3.0-R02	■	■	■				766-55-3.0-R02	■	■	■			

7XX-XX-B



Sur demande pour serrage type B, voir page 1.03  
Wahlweise mit B-Spannsystem, siehe Seite 1.03  
On request for B clamping system, see page 1.03

■ = disponible / verfügbar / available  
□ = selon disponibilité du stock / jenach Lagerverfügbarkeit / depending on stock availability

- Filetage
- Gewinde drehen
- Threading

756-AG60° / 766-AG60°  
756-G60° / 766-G60°

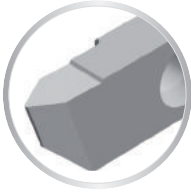
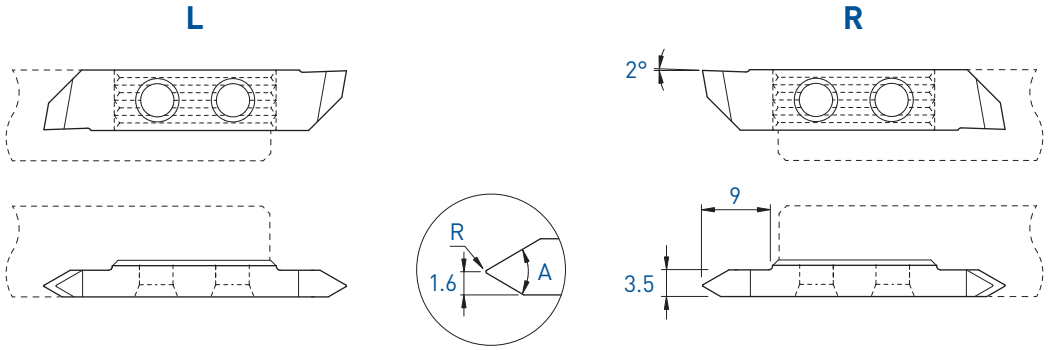

Profil partiel  
Teilprofil  
Partial profile



			L			R				
A	R	Pas Steigung Pitch P	Art. N°	TiAIN	TiN	N (µk20)	Art. N°	TiAIN	TiN	N (µk20)
60°	0.06	0.50-1.50	756-AG60°	■	■	■	766-AG60°	■	■	■
60°	0.20	1.75-3.00	756-G60°	■	■	■	766-G60°	■	■	■

7XX-XX-B



Sur demande pour serrage type B, voir page 1.03  
Wahlweise mit B-Spannsystem, siehe Seite 1.03  
On request for B clamping system, see page 1.03

Filetage

Gewinde drehen

Threading

756-M / 766-M

L

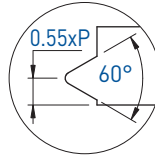
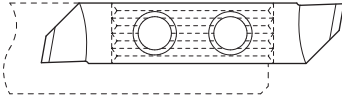

R

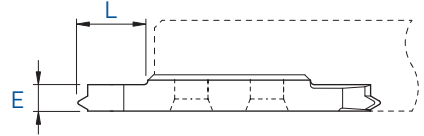
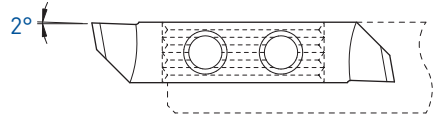

Profil complet métrique  
Metrisches Vollprofil  
Metric full profile

L

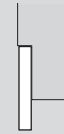

R



E	L	Pas Steigung Pitch P	L			R				
			Art. N°	TiAIN	TiN	N (µk20)	Art. N°	TiAIN	TiN	N (µk20)
2.5	8	0.80	756-M-0.80	■	■	■	766-M-0.80	■	■	■
2.5	8	1.00	756-M-1.00	■	■	■	766-M-1.00	■	■	■
2.5	8	1.25	756-M-1.25	■	■	■	766-M-1.25	■	■	■
3.5	9	1.50	756-M-1.50	■	■	■	766-M-1.50	■	■	■
3.5	9	1.75	756-M-1.75	■	■	■	766-M-1.75	■	■	■
3.5	9	2.00	756-M-2.00	■	■	■	766-M-2.00	■	■	■

Pour de plus petits pas, voir page 1.65  
Für kleinere Steigungen, siehe Seite 1.65  
For smaller pitches, see page 1.65

7XX-XX-B

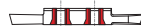

Sur demande pour serrage type B, voir page 1.03  
Wahlweise mit B-Spannsystem, siehe Seite 1.03  
On request for B clamping system, see page 1.03

■ = disponible / verfügbar / available  
□ = selon disponibilité du stock / jenach Lagerverfügbarkeit / depending on stock availability

new

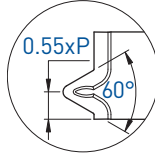
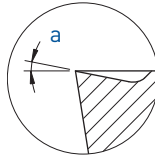

R

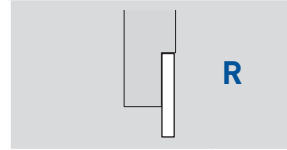
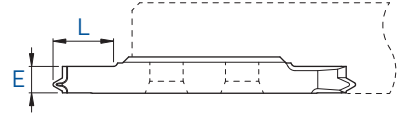
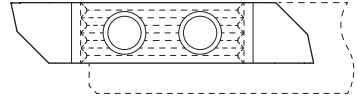

a	E	L	P	Art. N°	TiAIN	LOX
10°	2.5	8	0.80	766ZX10-M-0.80	■	□
	2.5	8	1.00	766ZX10-M-1.00	■	□
	2.5	8	1.25	766ZX10-M-1.25	■	□
	3.5	9	1.50	766ZX10-M-1.50	■	□
	3.5	9	1.75	766ZX10-M-1.75	■	□
	3.5	9	2.00	766ZX10-M-2.00	■	□

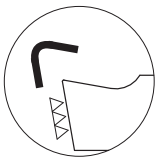

Arête de coupe honée  
Gehonte Schneidkante  
Honed edge

7XX-XX-B

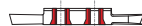

Sur demande pour serrage type B, voir page 1.03  
Wahlweise mit B-Spannsystem, siehe Seite 1.03  
On request for B clamping system, see page 1.03

Plaquettes à rayon  
 Radius Wendeplatten  
 Radius inserts

757 / 767

L

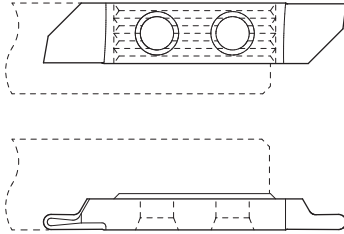

R

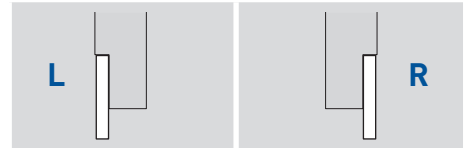
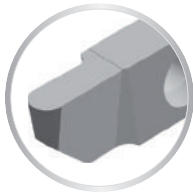
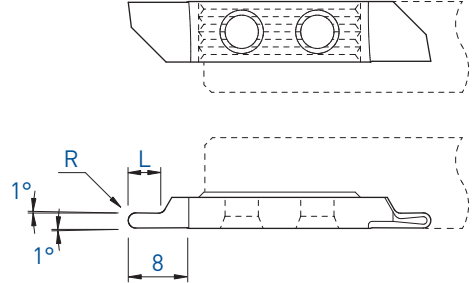

R	L	Art. N°	TiAlN			Art. N°	TiN		
			TiAlN	TiN	N (μk20)		TiAlN	TiN	N (μk20)
0.5	2.5	757-R0.5	■	■	■	767-R0.5	■	■	■
1.0	4	757-R1.0	■	■	■	767-R1.0	■	■	■
1.5	6	757-R1.5	■	■	■	767-R1.5	■	■	■
2.0	8	757-R2.0	■	■	■	767-R2.0	■	■	■

7XX-XX-B



Sur demande pour serrage type B, voir page 1.03  
 Wahlweise mit B-Spannsystem, siehe Seite 1.03  
 On request for B clamping system, see page 1.03

■ = disponible / verfügbar / available  
 □ = selon disponibilité du stock / jenach Lagerverfügbarkeit / depending on stock availability

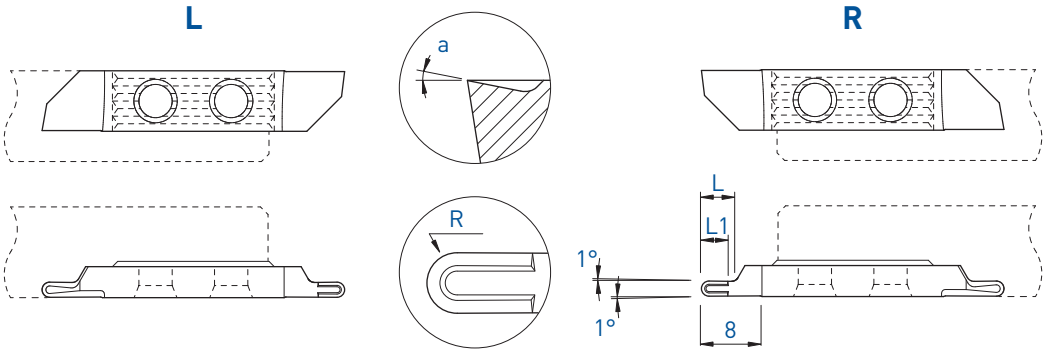

Pour un meilleur contrôle des copeaux  
 Für eine bessere Spankontrolle  
 For a better chip-control

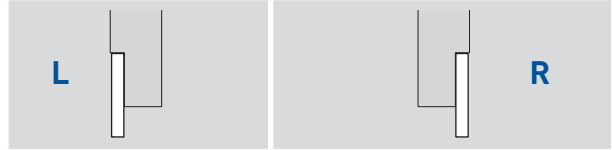

a	R	L	L1	Art. N°	L			Art. N°	R			HTA	HN (µk10)
					TiAlN	TiN	N (µk20)		TiAlN	TiN	N (µk20)		
10°	1.0	4	3.5	757ZX10-R1.0	■	□		767ZX10-R1.0	■	□			
	1.5	6	4.0	757ZX10-R1.5	■	□		767ZX10-R1.5	■	□			
	2.0	8	4.5	757ZX10-R2.0	■	□		767ZX10-R2.0	■	□	■		



Arête de coupe honée  
 Gehonte Schneidkante  
 Honed edge

f min: 0.02 mm/U

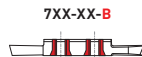

7XX-XX-B Sur demande pour serrage type B, voir page 1.03  
 Wahlweise mit B-Spannsystem, siehe Seite 1.03  
 On request for B clamping system, see page 1.03

Plaquettes ébauches  
WSP-Rohlinge  
Blank inserts

751-E / 761-E  
751-EP / 761-EP

L

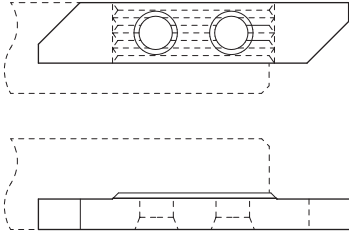

7XX-XX-B



Sur demande pour serrage type B, voir page 1.03  
Wahlweise mit B-Spannsystem, siehe Seite 1.03  
On request for B clamping system, see page 1.03

R

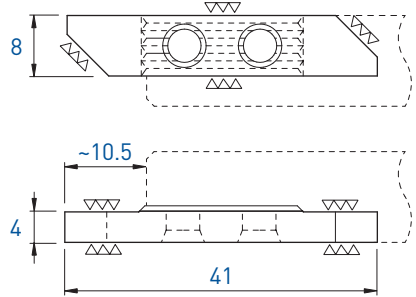

L		R	
Art. N°	N (µk20) HN (µk10)	Art. N°	N (µk20) HN (µk10)
751-E	■ ■	761-E	■ ■

L

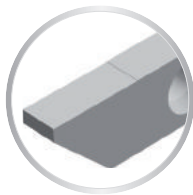
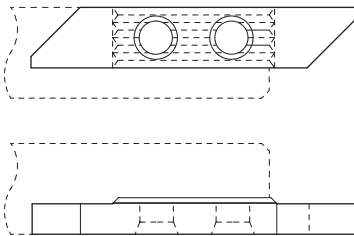

Face de coupe polie  
Polierte Schneidfläche  
Polished cutting face

R

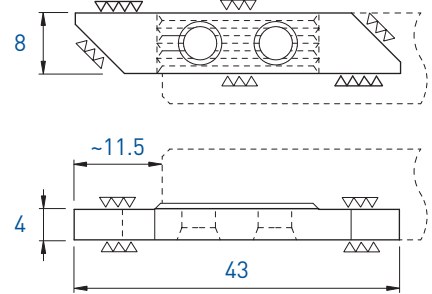

L					R				
Art. N°	TiAlN	TiN	N (µk20)	HTA HTiN HN (µk10)	Art. N°	TiAlN	TiN	N (µk20)	HTA HTiN HN (µk10)
751-EP	■	■	■	□ □ ■	761-EP	■	■	■	■ □ ■

770 / 780  
7050 / 7060  
W750 / W760

Porte-outils spécifiques  
Spezifische Werkzeughalter  
Specific tool holders

**770 / 780**

Tronçonnage de grande capacité  
Abstechen für grössere Durchmesser  
High capacity parting

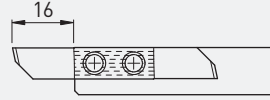

> **1.133**

**7050 / 7060**

Tronçonnage de grande capacité  
Abstechen für grössere Durchmesser  
High capacity parting

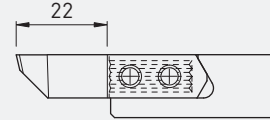

> **1.143**

**W750 / W760**

Outils avec plaquettes ébauches larges pour profilage  
Werkzeuge mit breiten WSP-Rohlingen für Profilschleifen  
Tools with wide blank inserts for profiling

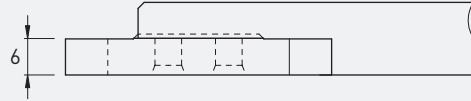

> **1.149**

*Porte-outils spécifiques / Spezifische Werkzeughalter / Specific tool holders*

**POLYGONAL INTERFACE C3 / C4 / HSK**

> **1.153**

**740Z / 760Z**

Porte-outils pour usinage déporté  
Halter für versetzte Bearbeitung  
Holders for shifted machining

> **1.156**

**DECO 7/10 - EvoDECO 10**

**R**

> **1.157**

**DECO 7/10 - EvoDECO 10**

**L**

> **1.159**

**Tornos**

**DECO 13 - EvoDECO 16  
DECO 20/26 - EvoDECO 20/32**

> **1.161**

**MultiSwiss 6x16**

> **1.163**

**AS14 / SAS16**

> **1.164**

**Schütte**

> **1.165**



Porte-outils

Halter

Holders

770 / 780

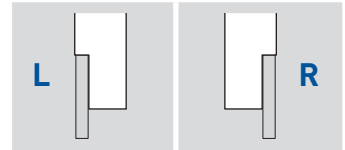
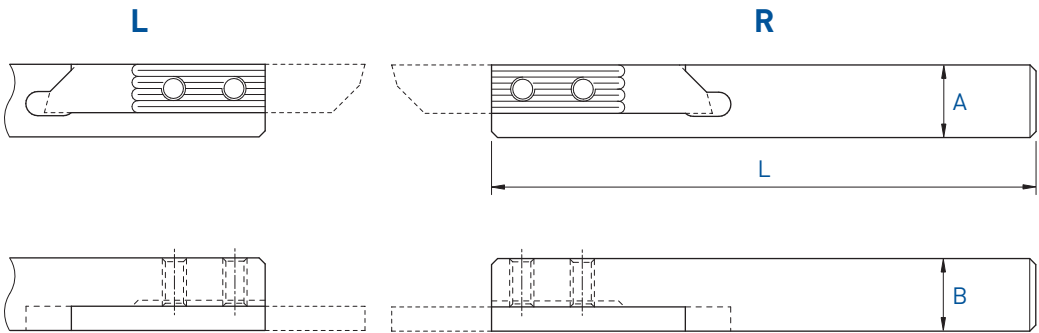

A x B	L	Serrage Spannsystem Clamping	Art. N°	Art. N°
10 x 10	115	A	<b>770-10</b>	<b>780-10</b>
12 x 12	130	A	<b>770-12</b>	<b>780-12</b>
12 x 12	90	A	<b>770-12-90</b>	<b>780-12-90</b>
12.7 x 12.7	130	A	<b>770-12.7</b>	<b>780-12.7</b>
14 x 14	130	A	<b>770-14</b>	<b>780-14</b>
16 x 16	130	A	<b>770-16</b>	<b>780-16</b>
16 x 16	75	A	<b>770-16-75</b>	<b>780-16-75</b>
20 x 20	120	A	<b>770-20</b>	<b>780-20</b>
25 x 25	140	A	<b>770-25</b>	<b>780-25</b>



Chaque support est livré avec vis et clé.  
 Jeder Halter wird mit Spannschraube(n) und Schlüssel geliefert.  
 Screw(s) and key are included with each tool holder.

# TOP-LINE

Porte-outils avec arrosage intégré  
 Halter mit integrierter Kühlmittelzufuhr  
 Holders with integrated coolant supply

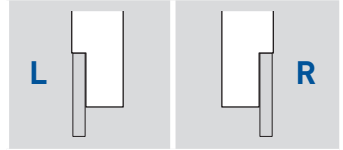
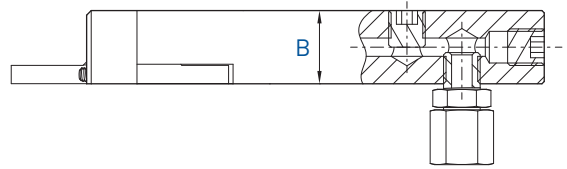
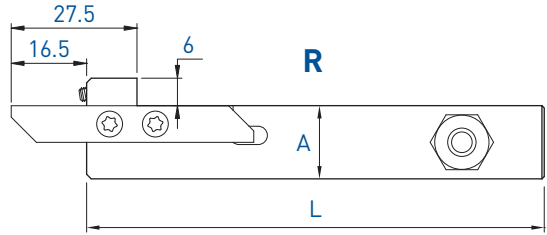
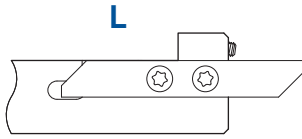

## 770-JET / 780-JET

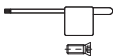

A x B	L	Serrage Spannsystem Clamping	Art. N°	Art. N°
16 x 16	100	A	770-16-JET	780-16-JET

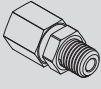

Chaque support est livré avec vis et clé.  
 Jeder Halter wird mit Spannschraube(n)  
 und Schlüssel geliefert.  
 Screw(s) and key are included with each  
 tool holder.

Pièces de rechange Ersatzteile Spare parts			Buse Düse Nozzle 
	Art. N°	Art. N°	Art. N°
770-JET / 780-JET	J-M8X1-D6	JB-M8X1	JJ-M3X6-D1.5

Porte-outils

Halter

Holders

Coupe déportée

Versetzttes Schneiden

Cut off line

770RC

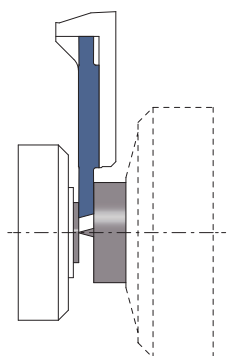
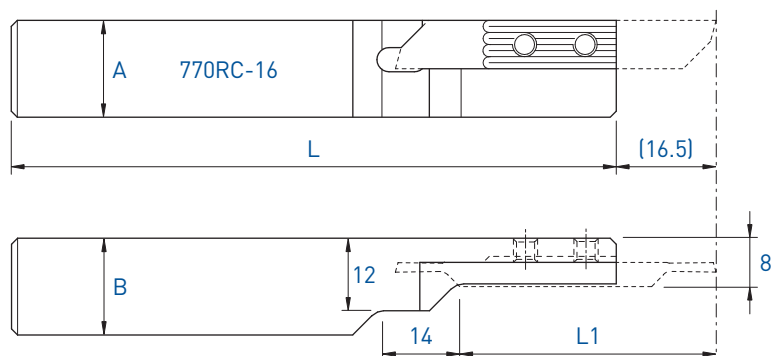
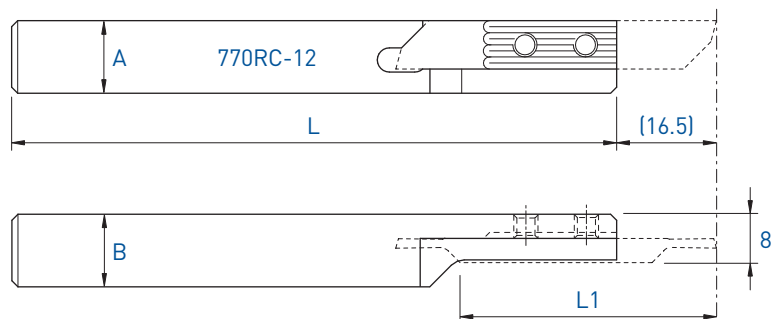

Utiliser des plaquettes type 771R  
WSP Typ 771R verwenden  
Use inserts type 771R

Voir pages 1.138 - 1.141  
Siehe Seiten 1.138 - 1.141  
See pages 1.138 - 1.141

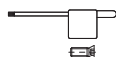

Chaque support est livré avec vis et clé.  
Jeder Halter wird mit Spannschraube(n) und Schlüssel geliefert.  
Screw(s) and key are included with each tool holder.

L (R)

Coupe à droite déportée  
Versetzttes Rechtsschneiden  
Right cut off line

A x B	L	L1	Serrage Spannsystem Clamping	Art. N°
12 x 12	130	42	A	<b>770RC-12</b>
16 x 16	130	42	A	<b>770RC-16</b>

L

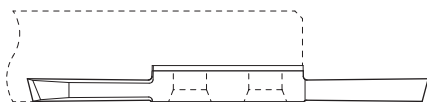
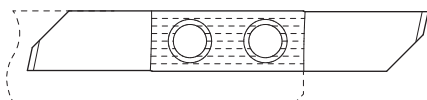

R

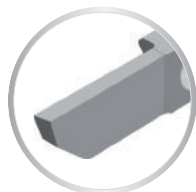
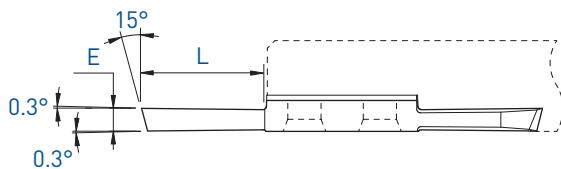
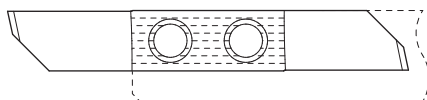

L



R



E	L	Art. N°	L			Art. N°	R		
			TiAlN	TiN	N (µk20)		TiAlN	TiN	N (µk20)
1.5	16	-				781-1.5	■	■	■
2.0	16	771-2.0	■	■	■	781-2.0	■	■	■
2.5	16	771-2.5	■	■	■	781-2.5	■	■	■
3.0	16	771-3.0	■	■	■	781-3.0	■	■	■
3.5	16	771-3.5	■	■	■	781-3.5	■	■	■

Tronçonnage

Abstechen

Parting off

771XF / 781XF

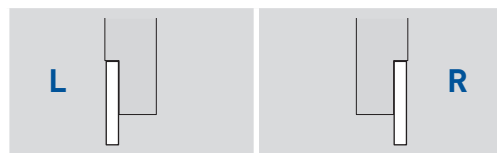
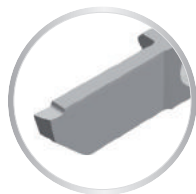
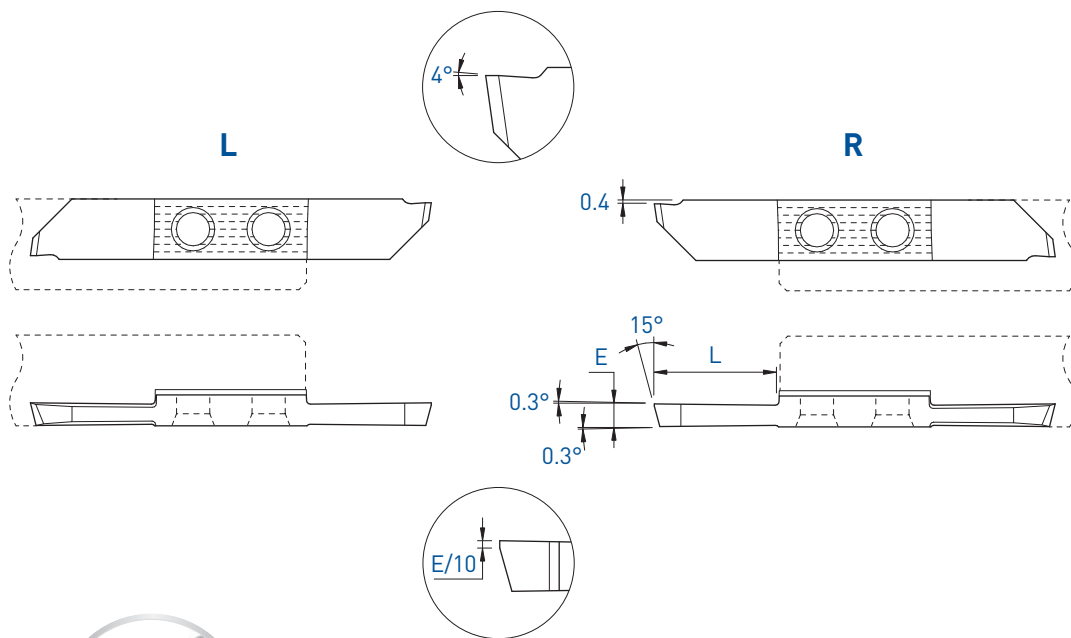

E	L	L			R				
		Art. N°	TiAlN	TiN	N (µk20)	Art. N°	TiAlN	TiN	N (µk20)
2.0	16	-				781XF-2.0	■	■	■
2.5	16	771XF-2.5	■	■	■	781XF-2.5	■	■	■
3.0	16	771XF-3.0	■	■	■	781XF-3.0	■	■	■
3.5	16	771XF-3.5	■	■	■	781XF-3.5	■	■	■

Tronçonnage

Abstechen

Parting off

Coupe déportée

Versetztes Schneiden

Cut off line

## 781L / 771R

### Cut R

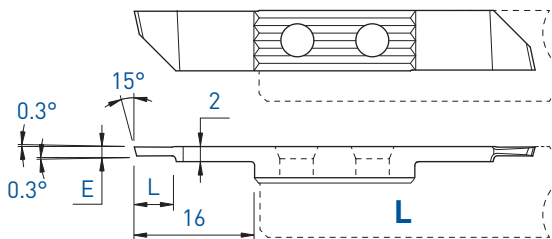

**L (R)**

Coupe à droite déportée  
Versetztes Rechtsschneiden  
Right cut off line

E	L	Art. N°	TiAlN	TiN	N (µk20)
1.0	5	771R-1.0	■	■	■
1.2	5	771R-1.2	■	■	■
1.5	8.5	771R-1.5	■	■	■

### Cut L

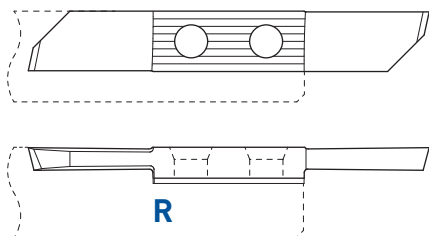

### Cut R

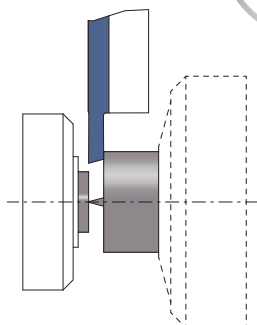
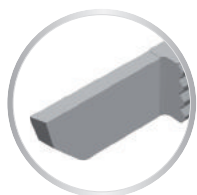
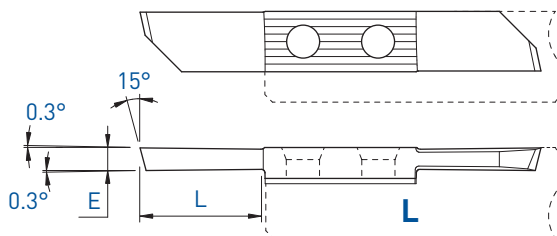

**R (L)**

Coupe à gauche déportée  
Versetztes Linksschneiden  
Left cut off line

**L (R)**

Coupe à droite déportée  
Versetztes Rechtsschneiden  
Right cut off line

E	L	Art. N°	TiAlN	TiN	N (µk20)	Art. N°	TiAlN	TiN	N (µk20)
2.0	16	781L-2.0	■	■	■	771R-2.0	■	■	■
2.5	16	781L-2.5	■	■	■	771R-2.5	■	■	■
3.0	16	781L-3.0	■	■	■	771R-3.0	■	■	■
3.5	16	781L-3.5	■	■	■	771R-3.5	■	■	■

Tronçonnage

Coupe déportée

Abstechen

Versetztsschneiden

Parting off

Cut off line

771RU

## Cut R

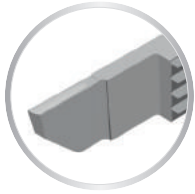
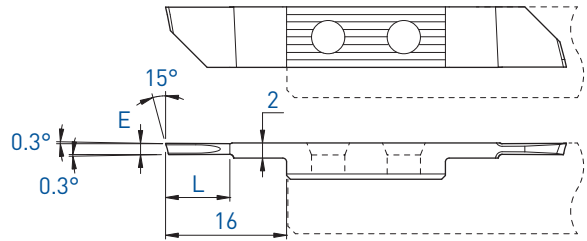

## L (R)

Coupe à droite déportée  
Versetztsschneiden  
Right cut off line

E	L	Art. N°	TiAlN	TiN	N (µk20)
1.0	5	771RU-1.0	■	□	■
1.5	8.5	771RU-1.5	■	□	■

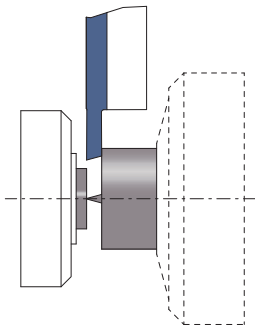

■ = disponible / verfügbar / available

□ = selon disponibilité du stock / jenach Lagerverfügbarkeit / depending on stock availability

# TOP-LINE

Tronçonnage  
Abstechen  
Parting off

Coupe déportée  
Versetztes Schneiden  
Cut off line

## 781LXF / 771RXF

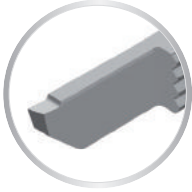
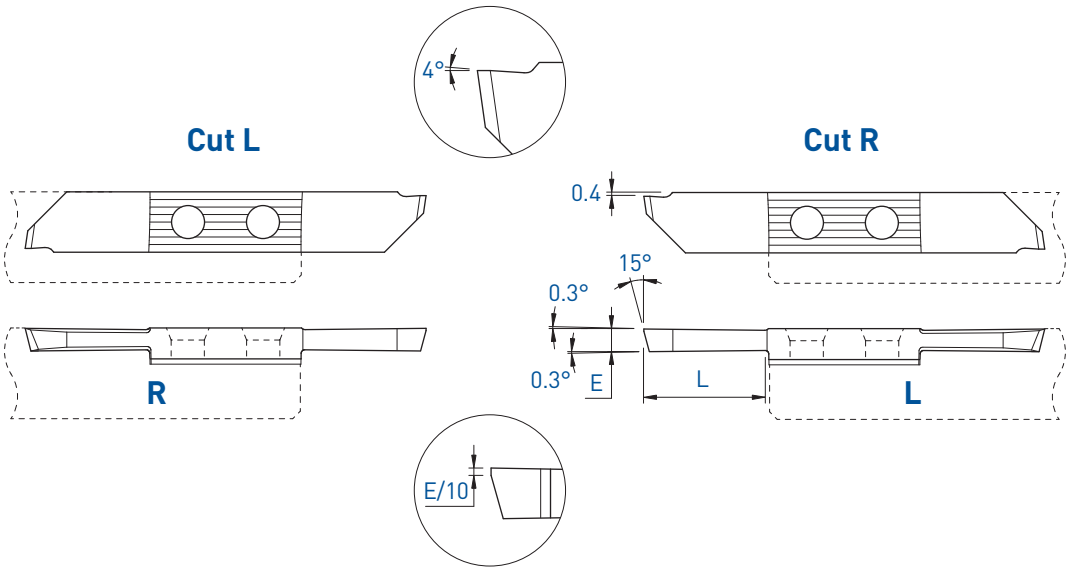

R (L)				L (R)			
Coupe à gauche déportée Versetztes Linksschneiden Left cut off line				Coupe à droite déportée Versetztes Rechtsschneiden Right cut off line			

E	L	Art. N°	TiAlN			Art. N°	TiAlN		
			TiN	N (µk20)	TiN		N (µk20)		
2.0	16	-				771RXF-2.0	■	■	■
2.5	16	781LXF-2.5	■	■	■	771RXF-2.5	■	■	■
3.0	16	781LXF-3.0	■	■	■	771RXF-3.0	■	■	■
3.5	16	781LXF-3.5	■	■	■	771RXF-3.5	■	■	■

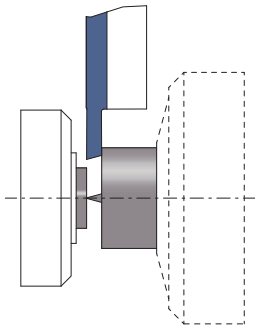



Tronçonnage

Abstechen

Parting off

Coupe déportée

Versetztes Schneiden

Cut off line

771RD

Cut R

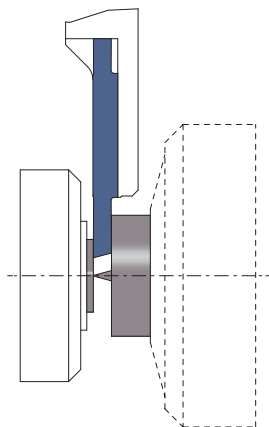
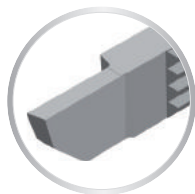
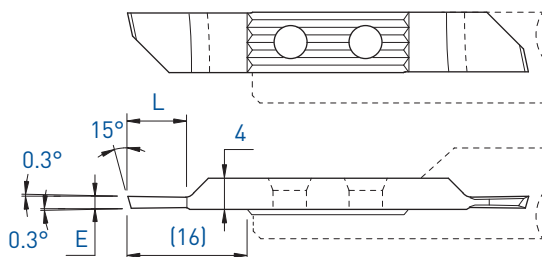

L (R)

Coupe à droite déportée  
Versetztes Rechtsschneiden  
Right cut off line

E	L	Art. N°	TiAlN	TiN	N (µk20)
1.2	5	771RD-1.2	■	■	■
1.5	7.5	771RD-1.5	■	■	■
2.0	10	771RD-2.0	■	■	■

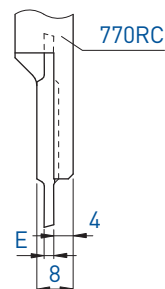

■ = disponible / verfügbar / available

□ = selon disponibilité du stock / jenach Lagerverfügbarkeit / depending on stock availability

# TOP-LINE

Plaquettes ébauches

WSP-Rohlinge

Blank inserts

771-E / 781-E

L

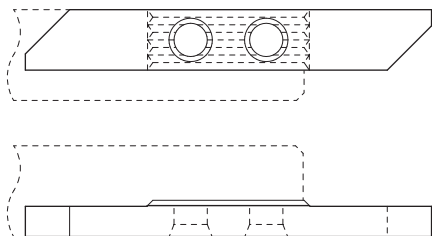

R

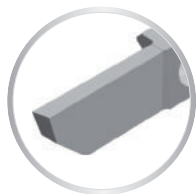
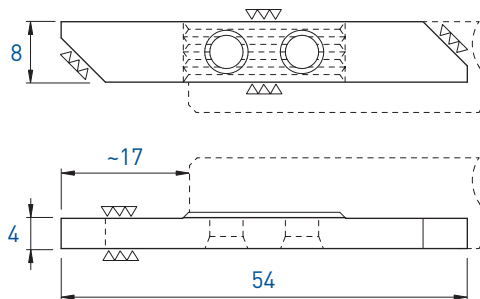

L		R	
Art. N°	N (µk20)	Art. N°	N (µk20)
771-E	■	781-E	■

Porte-outils

Halter

Holders

7050 / 7060

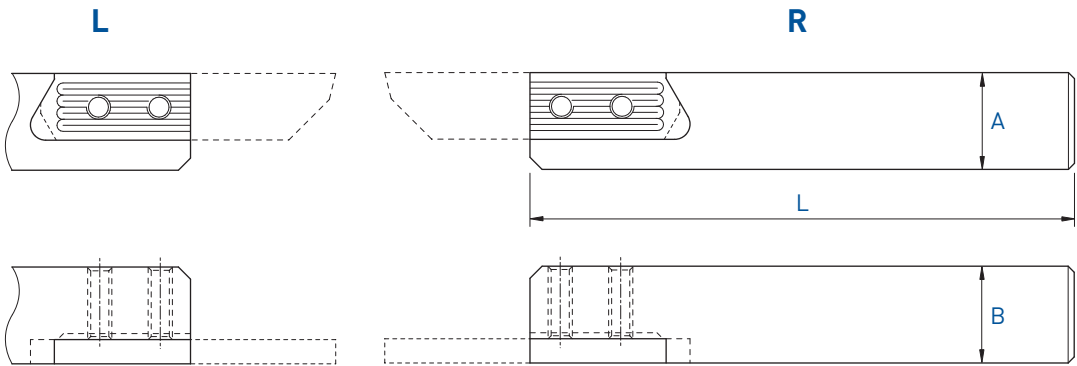

A x B	L	Serrage Spannsystem Clamping		
			Art. N°	Art. N°
16 x 16	130	A	<b>7050-16</b>	<b>7060-16</b>
16 x 16	75	A	<b>7050-16-75</b>	<b>7060-16-75</b>
20 x 20	120	A	<b>7050-20</b>	<b>7060-20</b>
25 x 25	140	A	<b>7050-25</b>	<b>7060-25</b>



Chaque support est livré avec vis et clé.  
 Jeder Halter wird mit Spannschraube(n) und Schlüssel geliefert.  
 Screw(s) and key are included with each tool holder.

■ = disponible / verfügbar / available

□ = selon disponibilité du stock / jenach Lagerverfügbarkeit / depending on stock availability

L

R

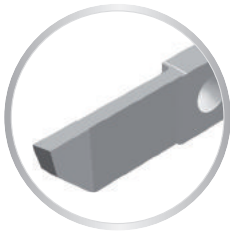
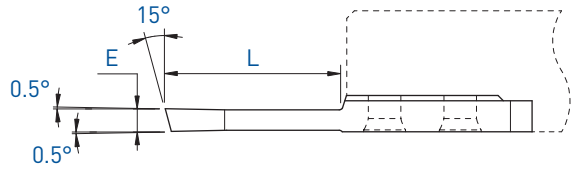
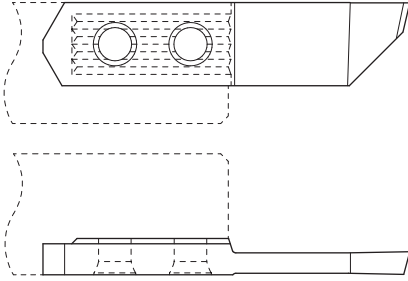

L

R

E	L	L			R				
		Art. N°	TiAlN	TiN	N [µk20]	Art. N°	TiAlN	TiN	N [µk20]
2.5	22	-				7061-2.5	■	■	■
3.0	22	7051-3.0	■	■	■	7061-3.0	■	■	■
3.5	22	-				7061-3.5	■	■	■

Tronçonnage

Abstechen

Parting off

7051XF / 7061XF

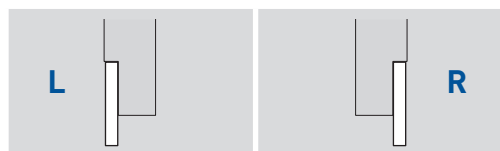
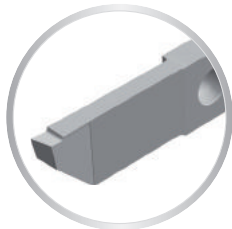
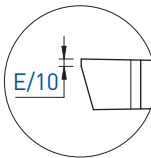
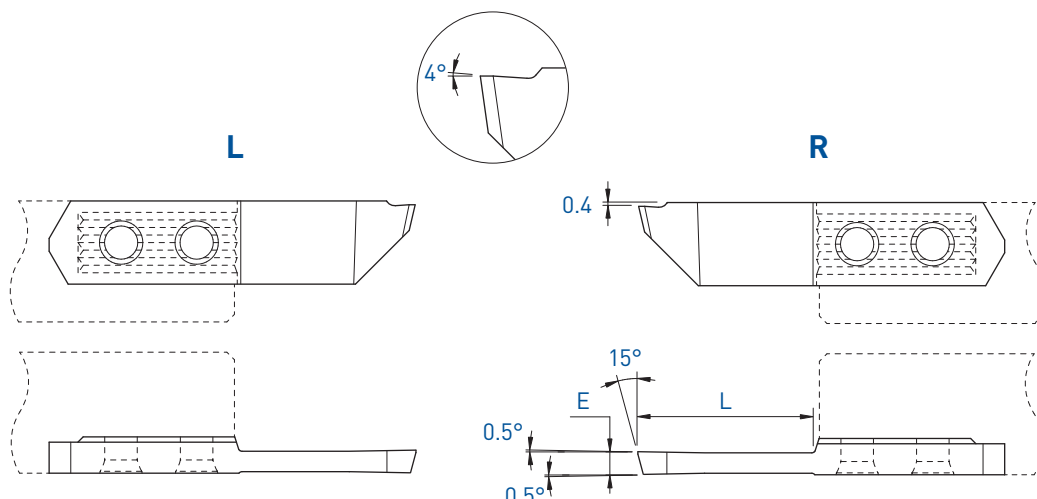

E	L	Art. N°	TiAlN	TiN	N [µk20]	Art. N°	TiAlN	TiN	N [µk20]
3.0	22	7051XF-3.0	■	■	■	7061XF-3.0	■	■	■

Tronçonnage

Abstechen

Parting off

Coupe déportée

Versetztes Schneiden

Cut off line

## 7061L / 7051R

### Cut L

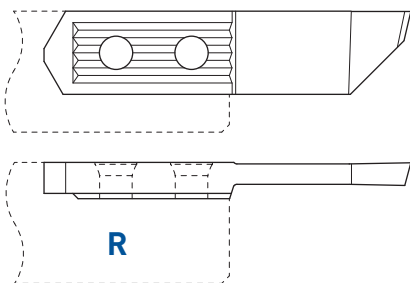

### Cut R

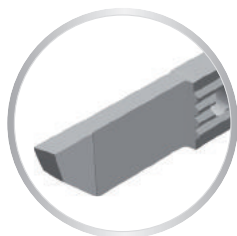
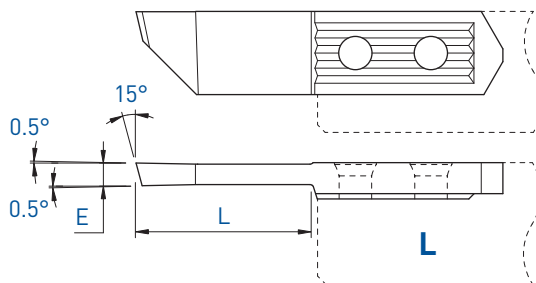

**R (L)**

Coupe à gauche déportée  
Versetztes Linksschneiden  
Left cut off line

**L (R)**

Coupe à droite déportée  
Versetztes Rechtsschneiden  
Right cut off line

E	L	Art. N°	TiAIN	TiN	N (µk20)	Art. N°	TiAIN	TiN	N (µk20)
2.5	22	-				7051R-2.5	■	■	■
3.0	22	7061L-3.0	■	■	■	7051R-3.0	■	■	■
3.5	22	-				7051R-3.5	■	■	■

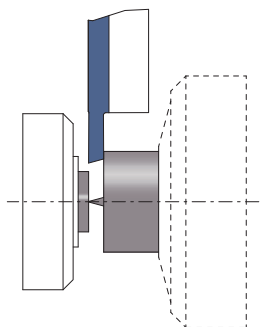

Tronçonnage  
Abstechen  
Parting off

Coupe déportée  
Versetztes Schneiden  
Cut off line

7061LXF / 7051RXF

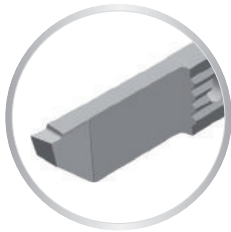
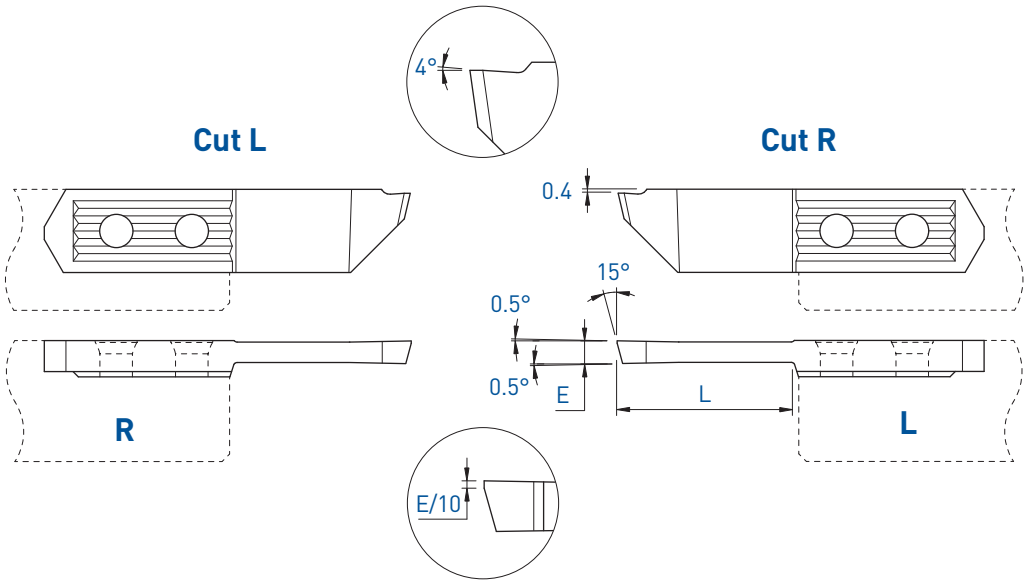

R (L)	L (R)
Coupe à gauche déportée Versetztes Linksschneiden Left cut off line	Coupe à droite déportée Versetztes Rechtsschneiden Right cut off line

E	L	Art. N°	TiAIN	TiN	N (µk20)	Art. N°	TiAIN	TiN	N (µk20)
3.0	22	7061LXF-3.0	■	■	■	7051RXF-3.0	■	■	■

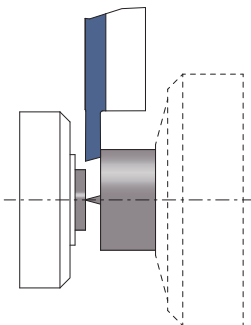

# TOP-LINE

Plaquettes ébauches

WSP-Rohlinge

Blank inserts

7051-E / 7061-E

L

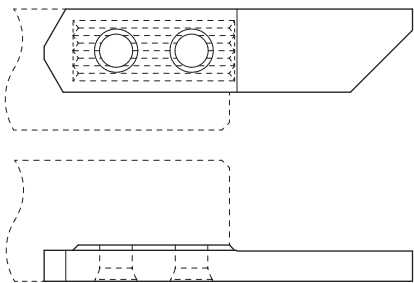

R

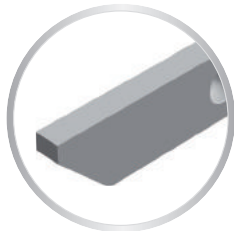
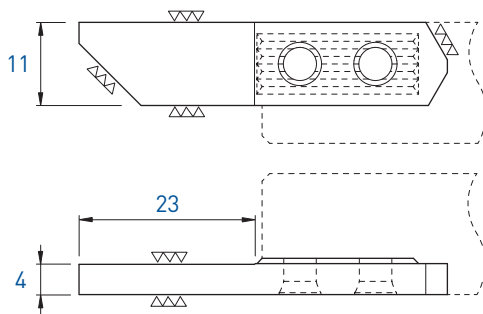

L		R	
Art. N°	N (µk20)	Art. N°	N (µk20)
7051-E	■	7061-E	■



Porte-outils

Halter

Holders

W750 / W760

L

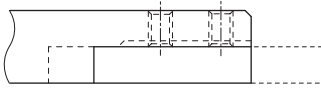
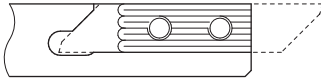

R

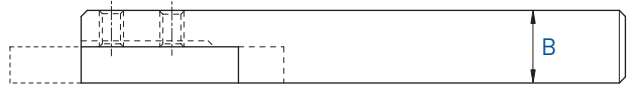
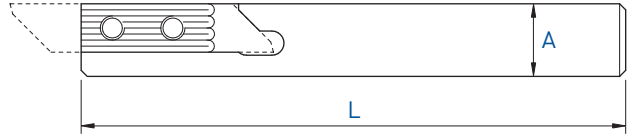

L

R

A x B	L	Serrage Spannsystem Clamping	Art. N°	Art. N°
12 x 12	130	A	<b>W750-12</b>	<b>W760-12</b>
16 x 16	130	A	<b>W750-16</b>	<b>W760-16</b>
20 x 20	120	A	<b>W750-20</b>	<b>W760-20</b>



Chaque support est livré avec vis et clé.  
Jeder Halter wird mit Spannschraube(n) und Schlüssel geliefert.  
Screw(s) and key are included with each tool holder.

■ = disponible / verfügbar / available

□ = selon disponibilité du stock / jenach Lagerverfügbarkeit / depending on stock availability

# TOP-LINE

Porte-outils avec arrosage intégré  
 Halter mit integrierter Kühlmittelzufuhr  
 Holders with integrated coolant supply

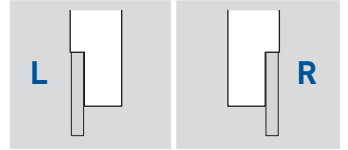
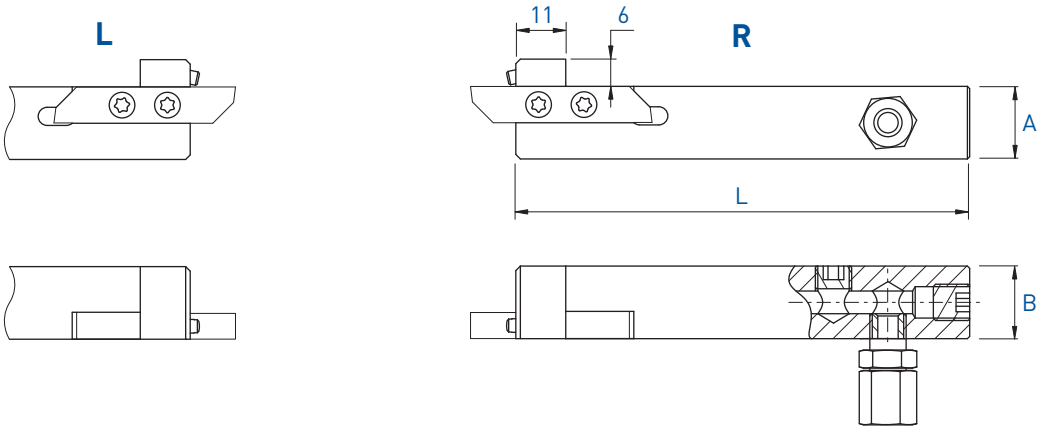

## W750-JET / W760-JET

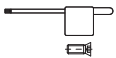

A x B	L	Serrage Spannsystem Clamping	Art. N°	Art. N°
16 x 16	100	A	W750-16-JET	W760-16-JET
20 x 20	100	A	W750-20-JET	W760-20-JET

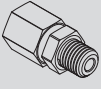

Chaque support est livré avec vis et clé.  
 Jeder Halter wird mit Spannschraube(n)  
 und Schlüssel geliefert.  
 Screw(s) and key are included with each  
 tool holder.

Pièces de rechange Ersatzteile Spare parts			Buse Düse Nozzle 
	Art. N°	Art. N°	Art. N°
W750-JET / W760-JET	J-M8X1-D6	JB-M8X1	JJ-M3X6-D1.5

Plaquettes ébauches  
WSP-Rohlinge  
Blank inserts

W751-E5 / W761-E5  
W751-EP5 / W761-EP5

L

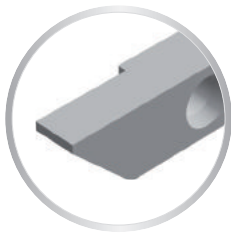
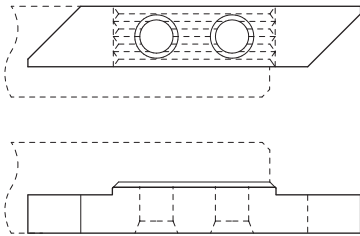

R

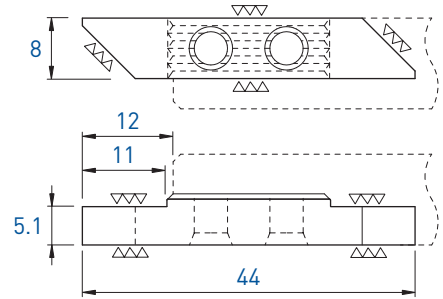

L		R	
Art. N°	N (µk20)	Art. N°	N (µk20)
W751-E5	■	W761-E5	■

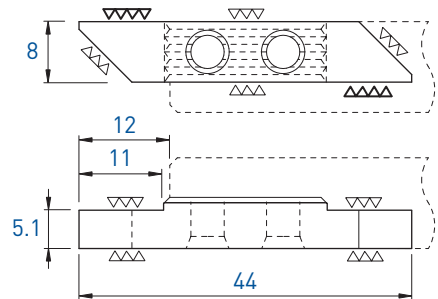
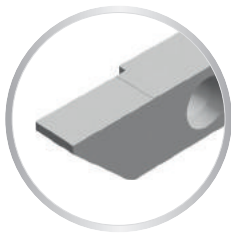
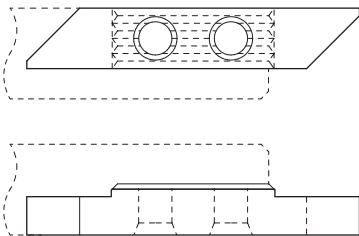

L		R	
Art. N°	N (µk20)	Art. N°	N (µk20)
W751-EP5	■	W761-EP5	■

# TOP-LINE

Plaquettes ébauches  
WSP-Rohlinge  
Blank inserts

W751-E6 / W761-E6  
W751-EP6 / W761-EP6

L

R

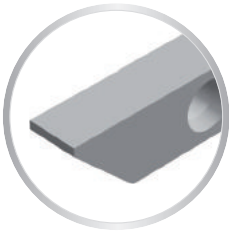
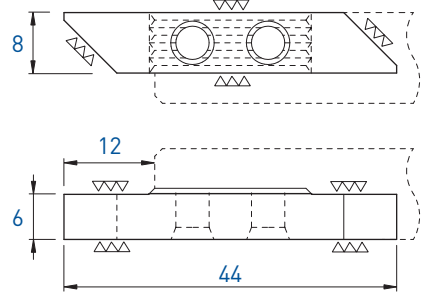
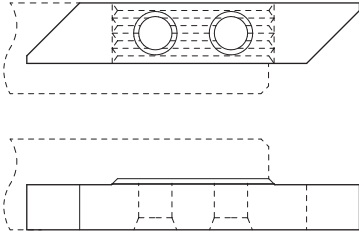

L		R	
Art. N°	N (µk20)	Art. N°	N (µk20)
W751-E6	■	W761-E6	■

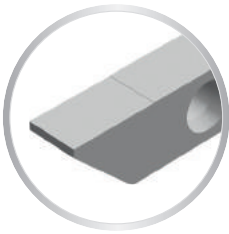
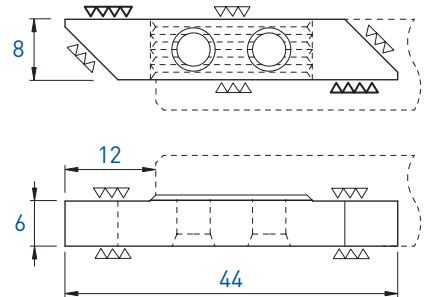
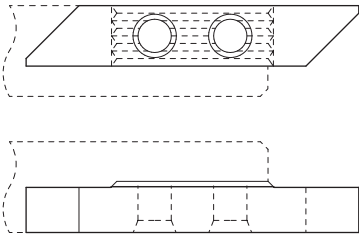

L		R	
Art. N°	N (µk20)	Art. N°	N (µk20)
W751-EP6	■	W761-EP6	■

Interface polygonale PSC  
 Polygonal Schnittstelle PSC  
 Polygonal interface PSC

R

C3 / C4

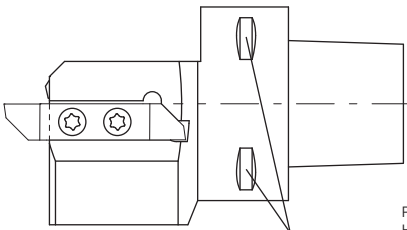
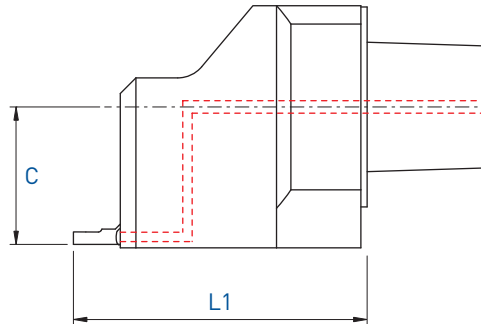
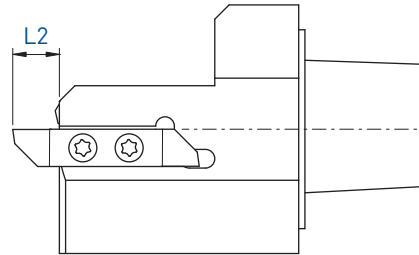
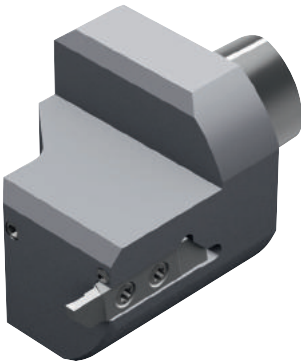

Porte-outils pour changeur automatique sur demande.  
 Halter für Werkzeugwechsler auf Anfrage.  
 Holders for tool changer on request.

Type	Plaquettes type WSP Typ Insert type	Pages Seiten Pages	L1	C	L2	Art. N°	Buse Düse Nozzle
							Art. N°
C3	740	> 1.32	47	22	7.5	<b>C3-740-22047</b>	<b>JJ-M3X6-D1.5</b>
C3	760	> 1.78	47	22	10	<b>C3-760-22047</b>	<b>JJ-M3X6-D1.5</b>
C4	760	> 1.78	62	27	10	<b>C4-760-27062</b>	<b>JJ-M3X6-D1.5</b>



Chaque support est livré avec vis et clé.  
 Jeder Halter wird mit Spannschraube(n) und Schlüssel geliefert.  
 Screw(s) and key are included with each tool holder.

■ = disponible / verfügbar / available  
 □ = selon disponibilité du stock / jenach Lagerverfügbarkeit / depending on stock availability

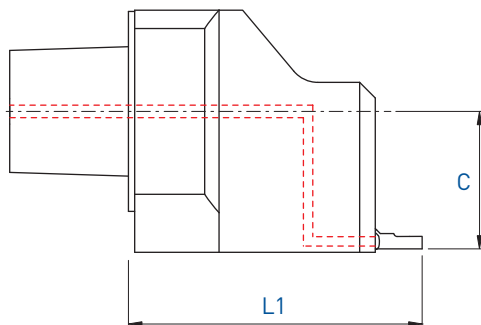
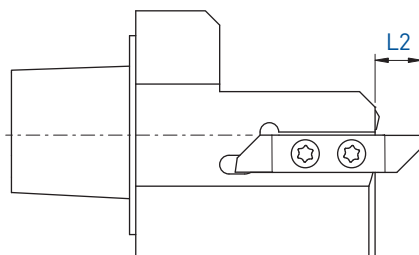

Type	Plaquettes type WSP Typ Insert type	Pages Seiten Pages	L1	C	L2	Art. N°	Buse Düse Nozzle Art. N°
C4	750	> 1.78	62	27	10	C4-750-27062	JJ-M3X6-D1.5

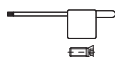

Chaque support est livré avec vis et clé.  
 Jeder Halter wird mit Spannschraube(n) und Schlüssel geliefert.  
 Screw(s) and key are included with each tool holder.

Porte-outils

Halter

Holders

HSK

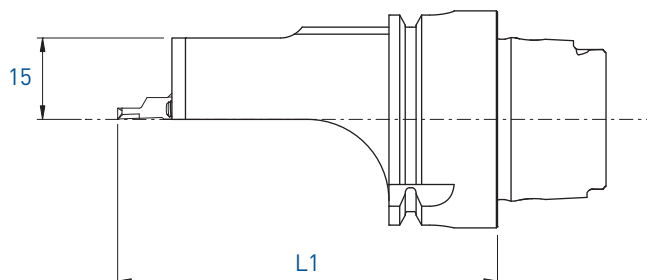
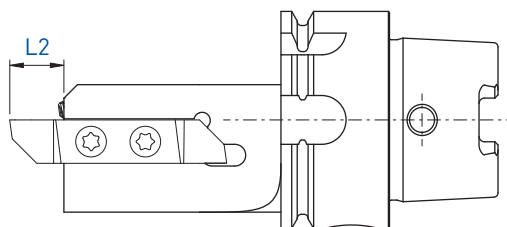

Utilisable sur toutes les machines avec broches HSK-T ou HSK-A

Auf allen Maschinen mit HSK-T oder HSK-A verwendbar

Applicable on all machines with HSK-T or HSK-A spindle

Plaquettes type WSP Typ Insert type	Pages Seiten Pages	L1	L2	Art. N°	Buse Düse Nozzle
					Art. N°
740	> 1.32	65	7.5	HSK-T40-740-0065-JET HSK-A40-S191-740-0065-JET*	JJ-M3X6-D1.5
760	> 1.78	70	10	HSK-T40-760-0070-JET HSK-A40-S191-760-0070-JET*	JJ-M3X6-D1.5

\* pour machines Bumotec  
für Bumotec Maschinen  
for Bumotec machines

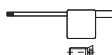

Chaque support est livré avec vis et clé.  
Jeder Halter wird mit Spannschraube(n) und Schlüssel geliefert.  
Screw(s) and key are included with each tool holder.

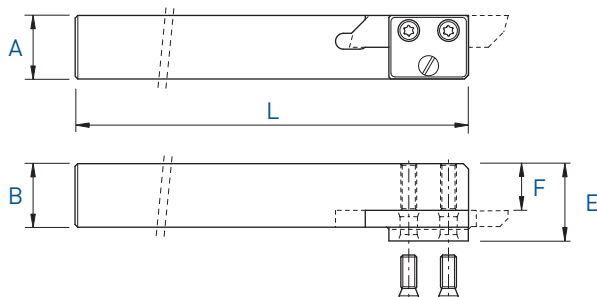
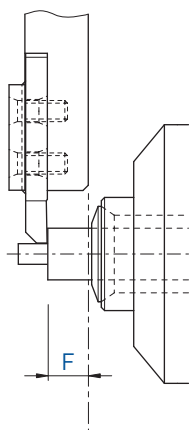

### 740 Series

A x B	L	F	E	Art. N°	Plaquettes type WSP Typ Inserts type	Pages Seiten Pages
12 x 12	130	9.5	14.5	<b>740Z-12</b>	741 - 747	> 1.32
16 x 16	130	13.5	18.5	<b>740Z-16</b>	741 - 747	> 1.32

### 760 Series

A x B	L	F	E	Art. N°	Plaquettes type WSP Typ Inserts type	Pages Seiten Pages
12 x 12	130	8	15	<b>760Z-12</b>	761 - 767	> 1.78
16 x 16	130	12	19	<b>760Z-16</b>	761 - 767	> 1.78

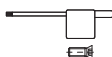

Chaque support est livré avec vis et clé.  
Jeder Halter wird mit Spannschraube(n) und Schlüssel geliefert.  
Screw(s) and key are included with each tool holder.



Porte-outils pour machine Tornos

Halter für Tornos Maschine

Holders for Tornos machine

R

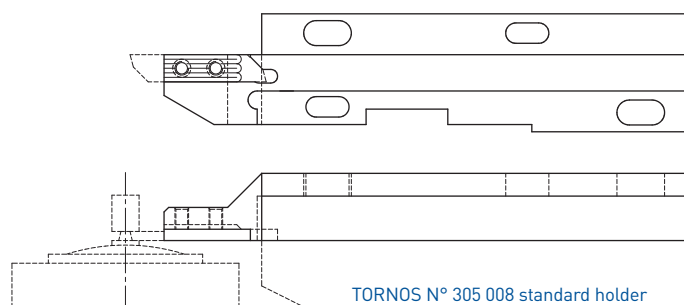
DECO 7/10  
EvoDECO 10Coupe à droite  
Rechtsschneiden  
Right hand cut

Art. N°	Plaquettes type WSP Typ Inserts type	Pages Seiten Pages
740-DECO10	741 - 747	> 1.32

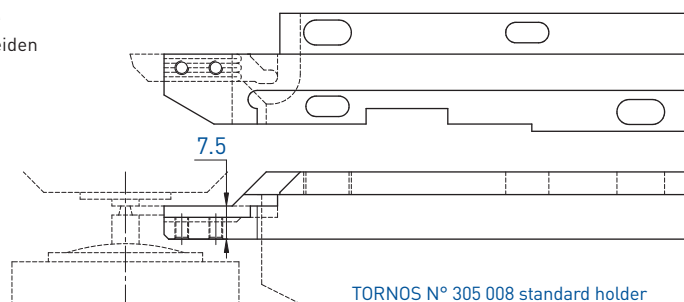
Coupe à droite déportée  
Versetztes Rechtsschneiden  
Right cut off line

Art. N°	Plaquettes type WSP Typ Inserts type	Pages Seiten Pages
730R-DECO10	731R / 731N	1.39 - 1.45

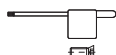

Chaque support est livré avec vis et clé.  
Jeder Halter wird mit Spannschraube(n) und Schlüssel geliefert.  
Screw(s) and key are included with each tool holder.

Pour le tronçonnage de petites pièces  
 Zum Abstechen von kleinen Werkstücken  
 For small parts parting off



Réglable en longueur  
 Längseinstellbar  
 Adjustable length

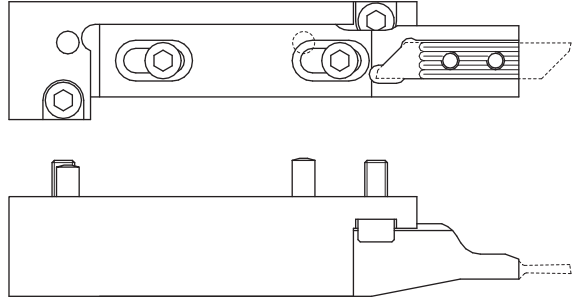

Art. N°	Plaquettes type WSP Typ Inserts type	Pages Seiten Pages
<b>750R-DECO10</b>	751R / 751N	1.88 - 1.99

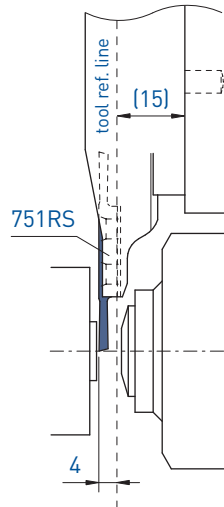
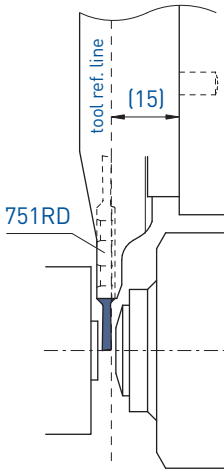

Chaque support est livré avec vis et clé.  
 Jeder Halter wird mit Spannschraubel(n) und Schlüssel geliefert.  
 Screw(s) and key are included with each tool holder.

Porte-outils pour machine Tornos

Halter für Tornos Maschine

Holders for Tornos machine

L

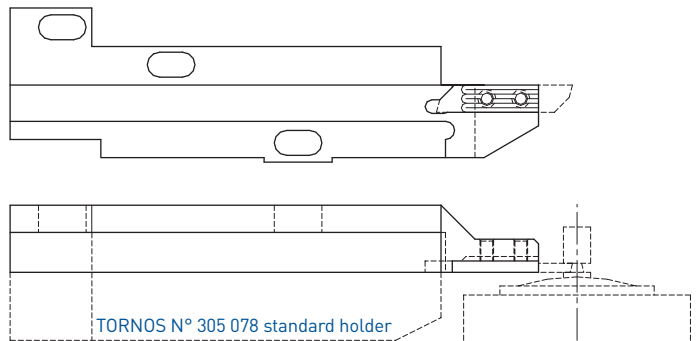
DECO 7/10  
EvoDECO 10Coupe à gauche  
Linksschneiden  
Left hand cut

Art. N°	Plaquettes type WSP Typ Inserts type	Pages Seiten Pages
730-DECO10	731 - 737	> 1.32

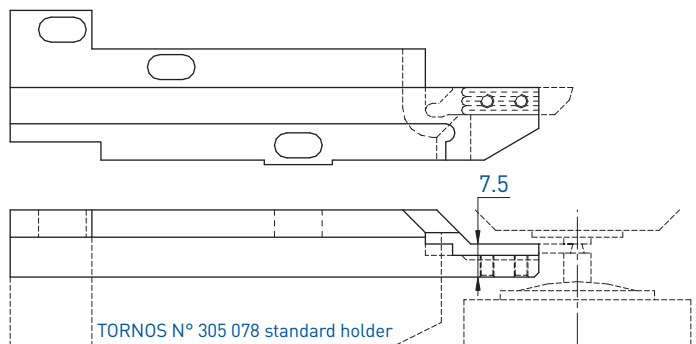
Coupe à gauche déportée  
Versetztes Linksschneiden  
Left cut off line

Art. N°	Plaquettes type WSP Typ Inserts type	Pages Seiten Pages
740L-DECO10	741L / 741N	1.39 - 1.45



Chaque support est livré avec vis et clé.  
Jeder Halter wird mit Spannschraub(en) und Schlüssel geliefert.  
Screw(s) and key are included with each tool holder.

Porte-outils pour machine Tornos

Halter für Tornos Maschine

Holders for Tornos machine

L

DECO 7/10  
EvoDECO 10

Pour le tronçonnage de petites pièces  
Zum Abstechen von kleinen Werkstücken  
For small parts parting off



Réglable en longueur  
Längseinstellbar  
Adjustable length

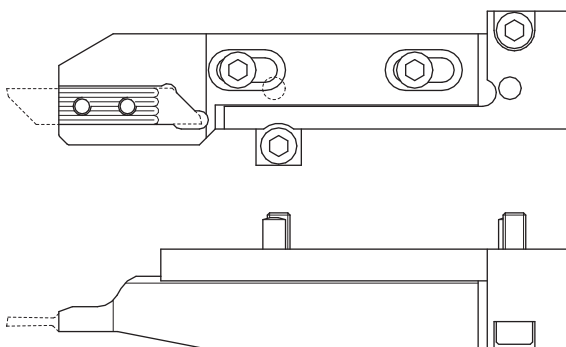

Art. N°	Plaquettes type WSP Typ Inserts type	Pages Seiten Pages
760L-DECO10	761L / 761N	1.88 - 1.98

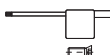
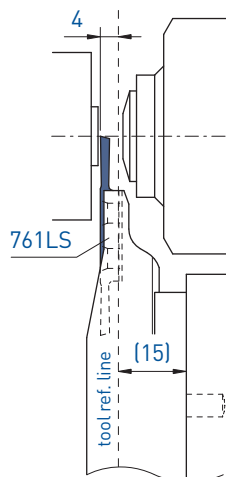
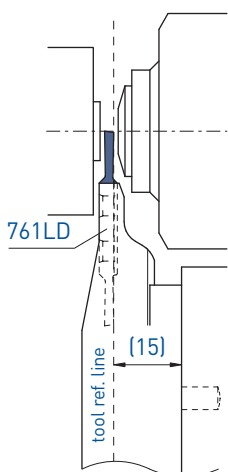

Chaque support est livré avec vis et clé.  
Jeder Halter wird mit Spannschraube(n) und Schlüssel geliefert.  
Screw(s) and key are included with each tool holder.

Porte-outils pour machine Tornos

Halter für Tornos Maschine

Holders for Tornos machine

DECO 13  
EvoDECO 16

Pour le tronçonnage de petites pièces  
Zum Abstechen von kleinen Werkstücken  
For small parts parting off

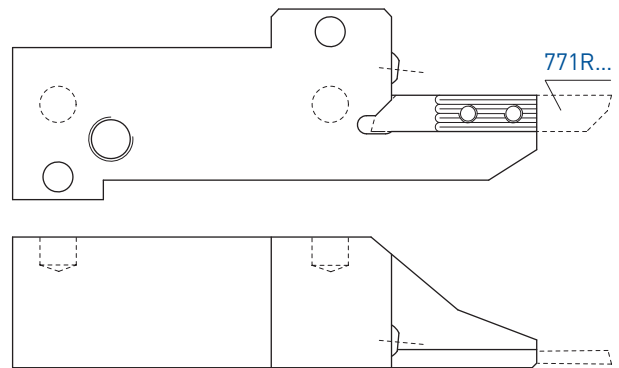

Art. N°	Plaquettes type WSP Typ Inserts type	Pages Seiten Pages
770R-DECO13	771R	1.138 - 1.141

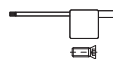
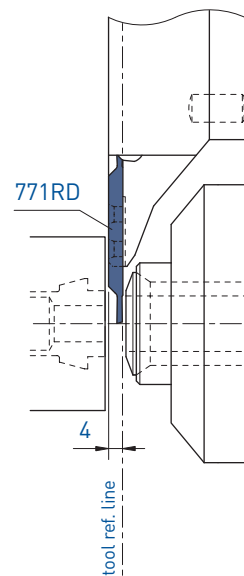
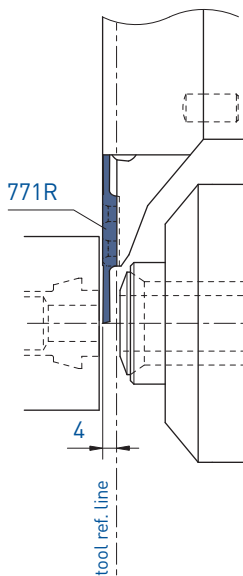

Chaque support est livré avec vis et clé.  
Jeder Halter wird mit Spannschraube(n) und Schlüssel geliefert.  
Screw(s) and key are included with each tool holder.

Porte-outils pour machine Tornos

Halter für Tornos Maschine

Holders for Tornos machine

**DECO 20**  
**EvoDECO 20/32**

Pour le tronçonnage de petites pièces  
Zum Abstechen von kleinen Werkstücken  
For small parts parting off

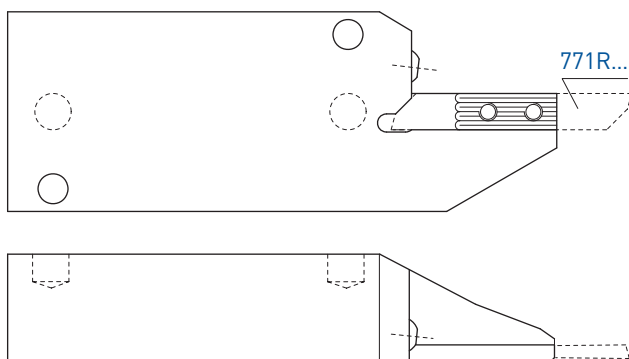

Art. N°	Plaquettes type WSP Typ Inserts type	Pages Seiten Pages
770R-DECO20	771R	1.138 - 1.141

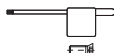
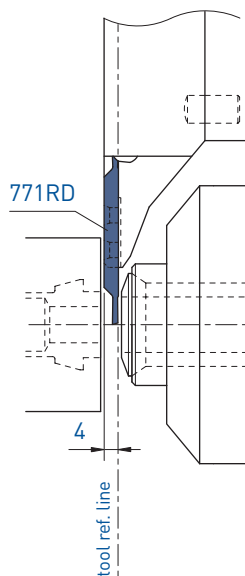
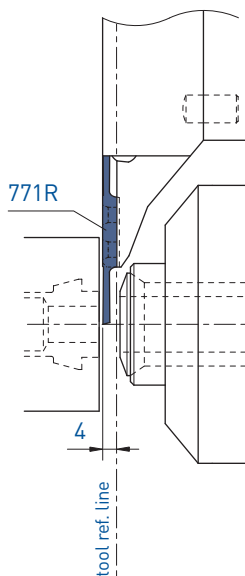

Chaque support est livré avec vis et clé.  
Jeder Halter wird mit Spanschraube(n) und Schlüssel geliefert.  
Screw(s) and key are included with each tool holder.

Porte-outils pour machine Tornos

Halter für Tornos Maschine

Holders for Tornos machine

MultiSwiss 6x16

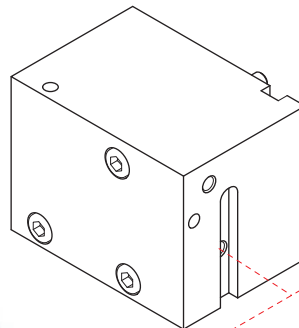
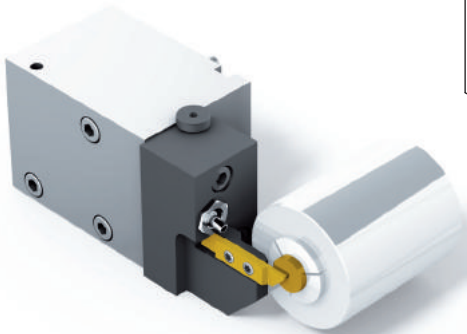
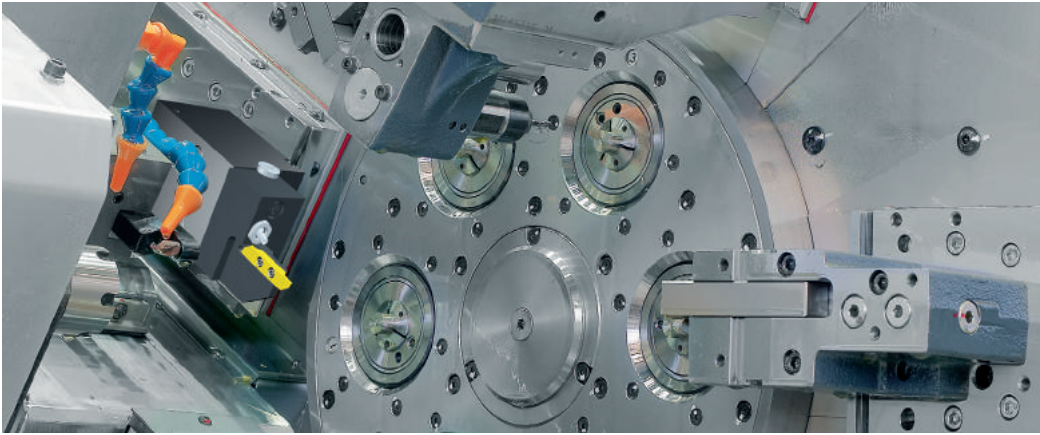

750R-MULTISWISS

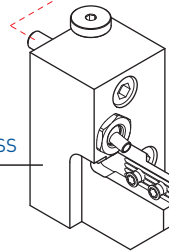

730R-MULTISWISS

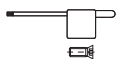
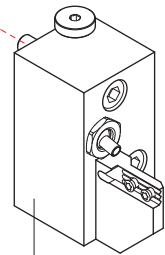

Chaque support est livré avec vis et clé.  
Jeder Halter wird mit Spannschraube(n) und Schlüssel geliefert.  
Screw(s) and key are included with each tool holder.

Art. N°	Plaquettes type WSP Typ Inserts type	Pages Seiten Pages
<b>730R-MULTISWISS</b>	731R / 731N	1.39 - 1.45
<b>750R-MULTISWISS</b>	751R / 751N	1.88 - 1.99

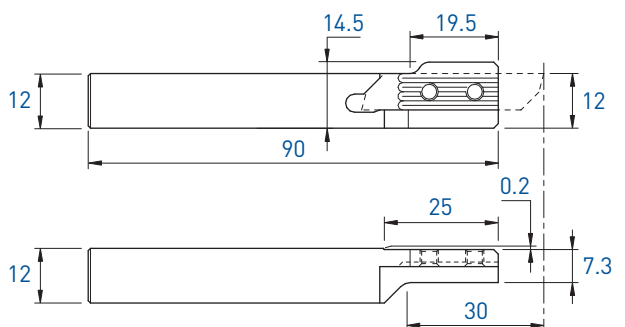

Art. N°	Plaquettes type WSP Typ Inserts type	Pages Seiten Pages
750RAS-12	751R	1.88 - 1.96

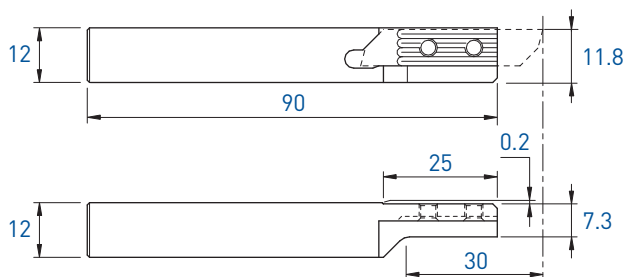

Art. N°	Plaquettes type WSP Typ Inserts type	Pages Seiten Pages
750RAS-12-H11.8	751R	1.88 - 1.96

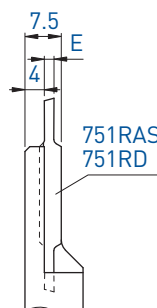
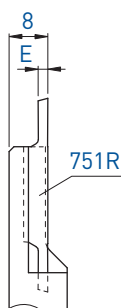
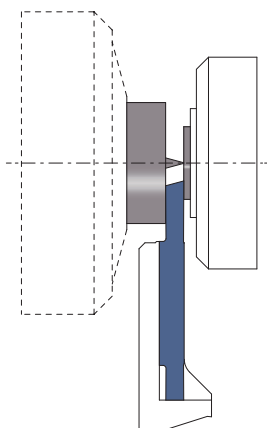

(p. 1.98 - 1.99)



Chaque support est livré avec vis et clé.  
Jeder Halter wird mit Spannschraube(n) und Schlüssel geliefert.  
Screw(s) and key are included with each tool holder.



Porte-outils

Halter

Holder

Schütze

DT20

DT30

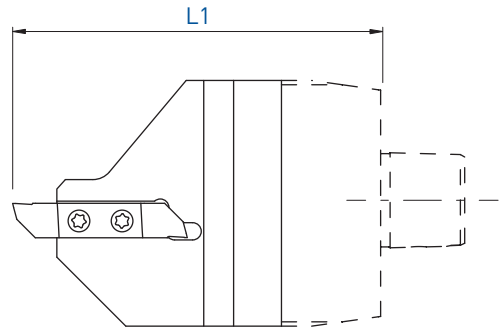

Compatibility Schütze

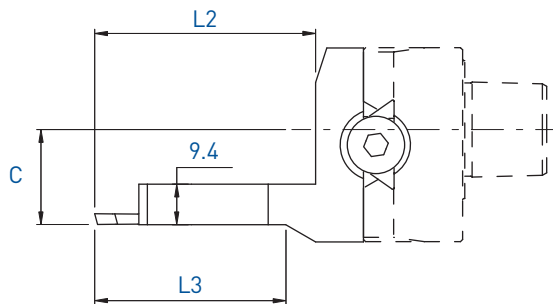
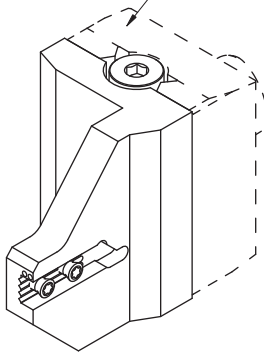

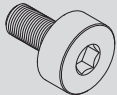

Plaquettes type WSP Typ Inserts type	Pages Seiten Pages	L1	C	L2	L3	Art. N°	Compatibility Schütze	
								Art. N°
761-767	> 1.78	86	22	51	44	DT20-760-JET	C3-75870949	V-M6X0.5-14-L18
		83	27.5	48	-	DT30-760-JET	C4-75836783	

## Vis et clés de rechange

## Ersatzschrauben und Schlüssel



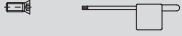
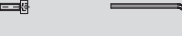

## Spare screws and keys

	Porte-outils Halter Holders	Serrage standard (A) Standard Spannsystem (A) Standard clamping system (A) 	Serrage type B Spannsystem Typ B Clamping system type B 
<b>710</b>	710-6 / - NOVIBRA	<b>V-M2.5X5.8-T8</b>	-
	710-7 / - NOVIBRA	<b>V-M2.5X6.5-T8</b>	
	710-8 / - NOVIBRA	<b>C-T8</b>	
	710-10 - 710-12		
<b>720</b>	720-7	<b>V-M2.5X6.5-T8</b>	-
	720-8 - 720-12	<b>V-M2.5X7.8-T8</b>	
<b>730</b>	730-7 / - JET / -NOVIBRA	<b>V-M3X7-T8</b>	-
	730-8 / -NOVIBRA		<b>V-M2.5X7.8-T8</b>
	730-10 - 730-20		<b>C-T8</b>
	730-DECO10		-
	730R-DECO10		-
<b>730RC</b>	<b>V-M3X5.5-T8</b>		
<b>740</b>	740-7 / -JET / -NOVIBRA	<b>V-M3X7-T8</b>	-
	740-8 / -NOVIBRA -		<b>V-M2.5X7.8-T8</b>
	740-12 / -JET / -NOVIBRA		<b>C-T8</b>
	740-16 - 740-20		
	740/730-D		
	740-C		<b>V-M3X5.5-T8</b>
	740-DECO10		<b>V-M3X7-T8</b>
740L-DECO10	<b>V-M3X9-T8</b>		
740-Z			
	Porte-outils Halter Holders	Serrage standard (A) Standard Spannsystem (A) Standard clamping system (A) 	Serrage type B Spannsystem Typ B Clamping system type B 
<b>750</b>	750-10 - 750-12 / -JET	<b>V-M4X9-T15</b>	-
	750-10-AB		<b>V-M3X10-BN11</b>
	750-12-AB		<b>V-M3X8-BN11</b>
	750-12.7 - 750-14		<b>V-M3X10-BN11</b>
	750-16		<b>V-M3X12-BN11</b>
	750-20		<b>V-M3X16-BN11</b>
	750RAS - 750-RC		<b>V-M4X7.3-T15</b>
750R-DECO10	<b>V-M4X5.6-T15</b>		
<b>760</b>	760-10 - 760-12 / -JET / -NOVIBRA /	<b>V-M4X9-T15</b>	-
	760/750		<b>V-M3X10-BN21</b>
	760-10-AB		<b>V-M3X8-BN11</b>
	760-12-AB		<b>V-M3X10-BN11</b>
	760-12.7 - 760-14		<b>V-M3X12-BN11</b>
	760-16		<b>V-M3X16-BN11</b>
	760-20		
	760LC		<b>V-M4X7.3-T15</b>
	760L-DECO10		<b>V-M4X5.6-T15</b>
760-Z	<b>V-M4X12-T15</b>		

## Vis et clés de rechange

## Ersatzschrauben und Schlüssel

## Spare screws and keys

	Porte-outils Halter Holders	Serrage standard (A) Standard Spannsystem (A) Standard clamping system (A)		Serrage type B Spannsystem Typ B Clamping system type B	
					
<b>770</b>	770 / -JET	V-M4X9-T15	C-T15	-	-
	770RC	V-M4X7.3-T15			
<b>780</b>	780 / -JET	V-M4X9-T15	C-T15	-	-
<b>7050</b>	7050	V-M4X9-T15	C-T15	-	-
<b>7060</b>	7060	V-M4X9-T15	C-T15	-	-
<b>W</b>	W750 / W760 / -JET	V-M4X11.5-T15	C-T15	-	-
<b>C3</b>	C3-740	V-M3X7-T8	C-T8	-	-
	C3-760	V-M4X9-T15	C-T15		
<b>C4</b>	C4-750	V-M4X9-T15	C-T15	-	-
	C4-760				
<b>HSK</b>	HSK-T40-740	V-M3X7-T8	C-T8	-	-
	HSK-T40-760	V-M4X9-T15	C-T15		
<b>MultiSwiss</b>	730R-MULTISWISS	V-M3X5.5-T8	C-T8	-	-
	750R-MULTISWISS	V-M4X7.3-T15	C-T15		
<b>Schütte</b>	DT20-760-JET	V-M4X9-T15	C-T15	-	-
	DT30-760-JET				

Nuances micro-grain à dureté élevée  
 Verschleissfeste Feinkornsorten  
 Wear resistant micro-grain grades > **2.02**

Pièces de rechange  
 Ersatzteile  
 Spare parts > **2.05**

	pour machines à cames für kurvengesteuerte Maschinen for cam driven machines		pour machines CNC für CNC-Maschinen for CNC driven machines		
	L		L	R	
	710 710SF 710-NOVIBRA	> <b>2.06</b>	730 730-NOVIBRA	740 740SF 740-NOVIBRA	> <b>2.10</b>
	711SF	> <b>2.08</b>		741SF	> <b>2.13</b>
	712SF	> <b>2.08</b>		742SF	> <b>2.13</b>
	713SF	> <b>2.09</b>		743SF	> <b>2.15</b>
			736SF	746SF	> <b>2.17</b>
				748SF	> <b>2.18</b>
				749SF	> <b>2.18</b>
	711-ESF	> <b>2.09</b>	731-ESF	741-ESF	> <b>2.19</b>

*Coupe à droite déportée / Versetztes Rechtsschneiden / Right cut off line*

**730RC**  
**750RC**

> **2.20**

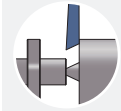

**731R**  
**751R**

> **2.21**

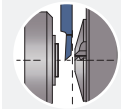

**770-SN-SF**

> **2.22** **new**

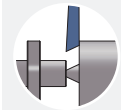

**771RVSF**

> **2.24** **new**

Halter für SwissNano  
Porte-outils pour Swissnano - MODU-Line  
Holder for SwissNano

**ML12**

> **2.24**

## Nuances micro-grain à dureté élevée

### Verschleissfeste Feinkornsorten

### Wear resistant micro-grain grades

**new**

#### N ( $\mu$ K20)

non revêtu  
unbeschichtet  
uncoated

- nuance micro-grain tenace, résistante aux conditions défavorables, recommandée pour des opérations de coupe dans des matières ne nécessitant aucun revêtement
- zähe Feinkornsorte, in ungünstige Bearbeitungs-konditionen widerstandsfähig, für Schnittbearbeitung empfohlen, die keine Beschichtung erfordern
- tough micro-grain grade, suitable for unfavorable machining conditions, suitable for cutting in material that do not necessitate any tool coating

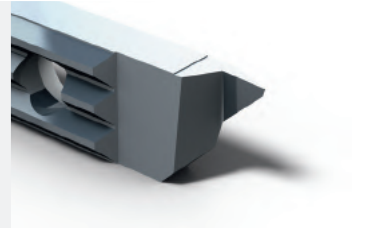

**new**

#### TAF

$\mu$ K20 + revêtement PVD  
 $\mu$ K20 + PVD Beschichtung  
 $\mu$ K20 + PVD coating

- nuance tenace résistante aux conditions défavorables, recommandée pour des opérations de coupes dans les aciers et aciers inoxydables.
- zähe widerstandsfähige Sorte in ungünstigen Bearbeitungskonditionen, für Schnittbearbeitung in Stahl und rostfreiem Stahl empfohlen
- tough grade, resistant to unfavorable machining conditions, suitable for cutting of steel and stainless steel

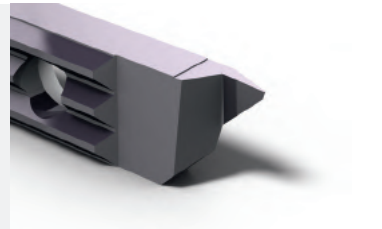

#### HN ( $\mu$ K10)

non revêtu  
unbeschichtet  
uncoated

- nuance micro-grain, bonne résistance à l'usure, recommandée pour des opérations d'ébauche et de finition pour des matières ou usinages ne nécessitant aucun revêtement
- verschleissfeste Feinkornsorte, für Schruppen und Schlichtbearbeitung empfohlen oder für Werkstoffe oder Bearbeitungen, die keine Beschichtung erfordern
- wear resistant micro-grain carbide, recommended for roughing and finishing and for materials or operations that do not necessitate any tool coating

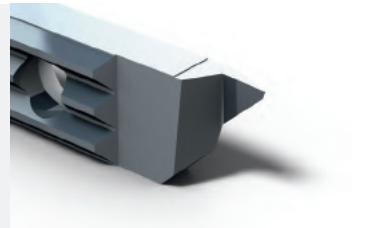

#### HTC

$\mu$ K10 + revêtement PVD  
 $\mu$ K10 + PVD Beschichtung  
 $\mu$ K10 + PVD coating

- nuance résistante à l'usure, faible coefficient de frottement, recommandée pour des opérations d'ébauche et de finition
- verschleissfeste Sorte, geringer Reibwert, für Schruppen und Schlichtbearbeitung empfohlen
- wear resistant grade, low friction ratio, recommended for roughing and finishing

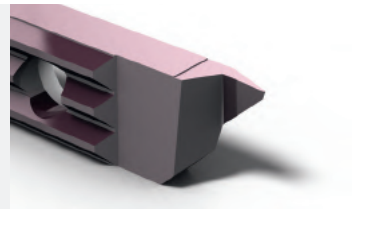

conseillée pour l'usinage de la matière 20AP  
für Bearbeitung von 20AP geeignet  
suitable for machining of 20AP material

#### HTC-RE

$\mu$ K10 + revêtement PVD  
 $\mu$ K10 + PVD Beschichtung  
 $\mu$ K10 + PVD coating

- nuance identique à HTC avec dépouilles rectifiées après revêtement pour des opérations de finition
- gleiche Sorte wie HTC nach der Beschichtung geschliffener Freiwinkel, für Schlichtbearbeitung empfohlen
- same grade as HTC, after coating grounded clearance, recommended for finishing

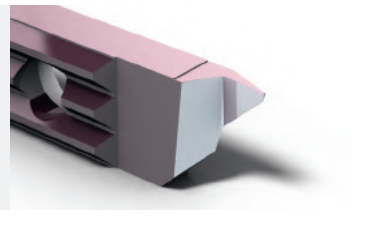

conseillée pour l'usinage de la matière 20AP  
für Bearbeitung von 20AP geeignet  
suitable for machining of 20AP material

## Nuances micro-grain à dureté élevée

### Verschleissfeste Feinkornsorten

### Wear resistant micro-grain grades

#### HTAF

μK10 + revêtement PVD  
μK10 + PVD Beschichtung  
μK10 + PVD coating

- nuance résistante à l'usure, recommandée pour des opérations d'ébauche et de finition
- verschleissfeste Sorte, für Schruppen und Schlichtbearbeitung empfohlen
- wear resistant grade, recommended for roughing and finishing

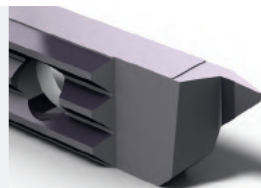

*conseillée pour l'usinage des matières Finemac et inox 4c27a  
für Bearbeitung von Finemac und 4c27a-Rostfreier Stahl geeignet  
suitable for machining of Finemac and 4c27a stainless steel*

#### HTAF-RE

μK10 + revêtement PVD  
μK10 + PVD Beschichtung  
μK10 + PVD coating

- nuance identique à HTAF avec dépouilles rectifiées après revêtement pour des opérations de finition
- gleiche Sorte wie HTAF nach der Beschichtung geschliffener Freiwinkel, für Schlichtbearbeitung empfohlen
- same grade as HTAF, after coating grounded clearance, recommended for finishing

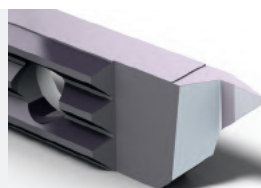

*recommandée pour les matières Finemac et inox 4c27a  
für Bearbeitung von Finemac und 4c27a-Rostfreier Stahl geeignet  
suitable for machining of Finemac and 4c27a stainless steel*

#### HTAXF

μK10 + revêtement PVD  
μK10 + PVD Beschichtung  
μK10 + PVD coating

- nuance complémentaire, résistante à l'usure et à la température pour l'usinage ébauche et finition des matières inox 304, 316L, 317L, 904, Phynox Aciers alliés contenant: Chrome Nickel, Vanadium, molybdène...
- komplementäre Sorte, verschleissfest und temperaturbeständig. Für Schruppen und Schlichtbearbeitung von Materialien Innox 304, 316L, 317L, 904, Phynox Legierter Stahl enthaltend Chrom-Nickel, Vanadium, Molybdän...
- complementary grade, wear and temperature resistant for roughing and finishing of following materials: Innox 304, 316L, 317L, 904, Phynox Alloy steel containing Chrome-nickel, Vanadium, Molybdenum...

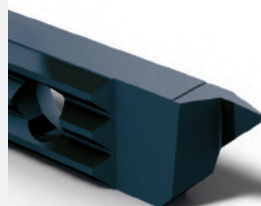

#### HTAXF-RE

μK10 + revêtement PVD  
μK10 + PVD Beschichtung  
μK10 + PVD coating

- nuance identique à HTAXF avec dépouilles rectifiées après revêtement pour des opérations de finition
- gleiche Sorte wie HTAXF nach der Beschichtung geschliffener Freiwinkel, für Schlichtbearbeitung empfohlen
- same grade as HTAXF, after coating grounded clearance, recommended for finishing

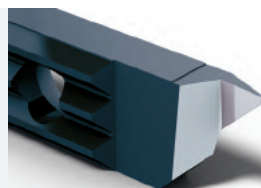

#### HTiN

μK10 + revêtement PVD  
μK10 + PVD Beschichtung  
μK10 + PVD coating

- nuance résistante à l'usure, faible coefficient de frottement, recommandée pour des opérations d'ébauche et de finition
- verschleissfeste Sorte, geringer Reibwert, für Schruppen und Schlichtbearbeitung empfohlen
- wear resistant grade, low friction ratio, recommended for roughing and finishing



Nuances micro-grain à dureté élevée

Verschleissfeste Feinkornsorten

Wear resistant micro-grain grades

## XN ( $\mu$ K01)

non revêtu  
unbeschichtet  
uncoated

- nuance micro-grain très résistante à l'usure, recommandée pour des opérations d'ébauche et de finition pour des matières ou usinages nécessitant aucun revêtement
- sehr verschleissfeste Sorte, für Schruppen und Schlichtbearbeitung empfohlen oder für Werkstoffe oder Bearbeitungen, die keine Beschichtung erfordern
- wear resistant micro-grain carbide, recommended for roughing and finishing and for materials or operations that do not necessitate any tool coating

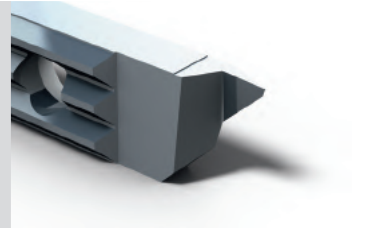

## XTC

$\mu$ K01 + revêtement PVD  
 $\mu$ K01 + PVD Beschichtung  
 $\mu$ K01 + PVD coating

- nuance très résistante à l'usure, faible coefficient de frottement, recommandée pour des opérations de finition
- sehr verschleissfeste Sorte, geringer Reibwert, für Schlichtbearbeitung empfohlen
- very wear resistant grade, low friction ratio, recommended for finishing

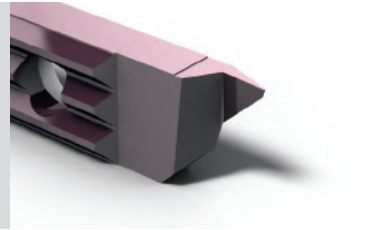

## XTAF

$\mu$ K01 + revêtement PVD  
 $\mu$ K01 + PVD Beschichtung  
 $\mu$ K01 + PVD coating

- nuance très résistante à l'usure, recommandée pour des opérations de finition, conseillée pour l'usinage des matières très abrasives
- sehr verschleissfeste Sorte, für Schlichtbearbeitung empfohlen, für die Bearbeitung von sehr abrasive Rohstoffe geeignet
- very wear resistant grade, recommended for finishing, suitable for machining of very abrasive materials

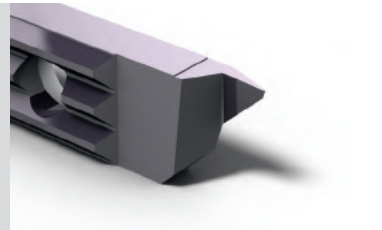

## XTAF-RE

$\mu$ K01 + revêtement PVD  
 $\mu$ K01 + PVD Beschichtung  
 $\mu$ K01 + PVD coating

- nuance identique à XTAF avec dépouilles rectifiées après revêtement pour des opérations de finition
- gleiche Sorte wie XTAF nach der Beschichtung geschliffener Freiwinkel, für Schlichtbearbeitung empfohlen
- same grade as XTAF, after coating grounded clearance, recommended for finishing

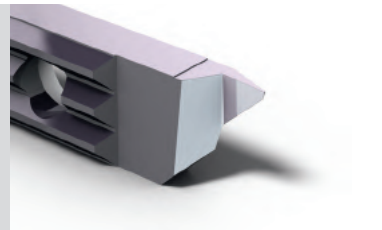



**Nuances micro-grain à dureté élevée**

**Verschleissfeste Feinkornsorten**

**Wear resistant micro-grain grades**

## XTAXF

μK01 + revêtement PVD  
μK01 + PVD Beschichtung  
μK01 + PVD coating

- nuance complémentaire très résistante à l'usure et à la température pour la finition des matières inox 304, 316L, 317L, 904, Phynox  
Aciers alliés contenant: Chrome Nickel, Vanadium, Molybdène...
- komplémentere Sorte, sehr verschleissfest und temperaturbeständig. Für Schlichtbearbeitung von Materialien Inox 304, 316L, 317L, 904, Phynox  
Legierter Stahl enthaltend Chrom-Nickel, Vanadium, Molybdän...
- complementary grade, very wear and temperature resistant for finishing of following materials: Inox 304, 316L, 317L, 904, Phynox  
Alloy steel containing Chrome-nickel, Vanadium, Molybdenum...

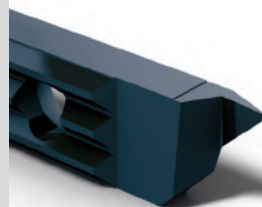

## XTAXF-RE

μK01 + revêtement PVD  
μK01 + PVD Beschichtung  
μK01 + PVD coating

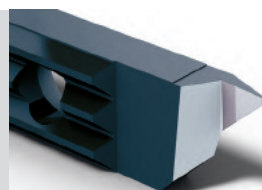

- nuance identique à XTAXF avec dépouilles rectifiées après revêtement pour des opérations de finition
- gleiche Sorte wie XTAXF nach der Beschichtung geschliffener Freiwinkel, für Schlichtbearbeitung empfohlen
- same grade as XTAXF, after coating grounded clearance, recommended for finishing



**Pièces de rechange**

**Ersatzteile**

**Spare parts**

Porte-outils Halter Holders		Serrage standard (A) Standard Spannsystem (A) Standard clamping system (A)		Serrage type B Spannsystem Typ B Clamping system type B	
					
710	710-6 / - NOVIBRA	V-M2.5X5.8-T8	C-T8	-	-
	710-7 / - NOVIBRA / - SF	V-M2.5X6.5-T8			
	710-8 / - NOVIBRA / -SF	V-M2.5X7.8-T8			
	710-10 - 710-12				
730	730-7 / - NOVIBRA	V-M3X7-T8	C-T8	-	-
	730-8 / - NOVIBRA			V-M2.5X7.8-T8	C-T8
	730-10 - 730-12			-	-
	730RC			V-M3X5.5-T8	-
740	740-7 / -NOVIBRA / -SF	V-M3X7-T8	C-T8	-	-
	740-8 -12 / -SF / -NOVIBRA			V-M2.5X7.8-T8	C-T8
750	750RC	V-M4X7.3-T15	C-T15	-	-
770	770-SN-SF	V-M4X7.3-T15	C-T15	-	-

Porte-outils

Halter

Holder

L

710

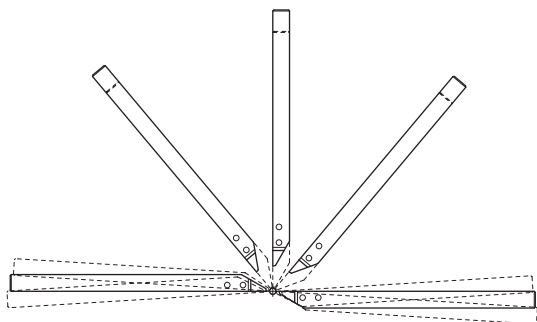

Porte-outils pour machines à cames à gauche  
 Halter für linksdrehende kurvgesteuerte Maschinen  
 Tool holders for left hand turning cam driven machines

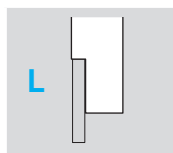
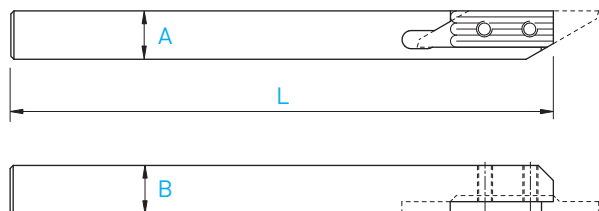

A x B	L	Serrage Spannsystem Clamping	Art. N°
6 x 6	115	A	<b>710-6</b>
7 x 7	115	A	<b>710-7</b>
8 x 8	115	A	<b>710-8</b>
8 x 8	140	A	<b>710-8-140</b>
10 x 10	115	A	<b>710-10</b>
12 x 12	130	A	<b>710-12</b>

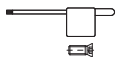

Chaque support est livré avec vis et clé.  
 Jeder Halter wird mit Spanschraube(n) und Schlüssel geliefert.  
 Screw(s) and key are included with each tool holder.

Porte-outils

Halter

Holders

L

710-SF

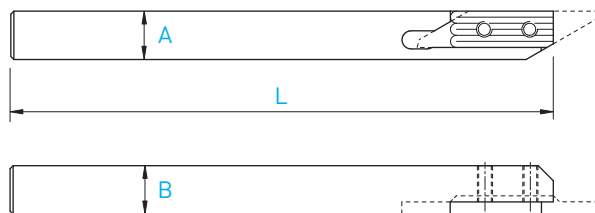

Super finition des 4 faces  
4 seitig feinstgeschliffen  
4 sides superfinish

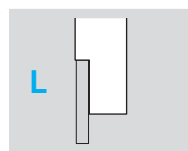

A x B	L	Serrage Spannsystem Clamping	Art. N°
7 x 7	140	A	710-7-140-SF
8 x 8	140	A	710-8-140-SF

Porte-outils en métal lourd anti-vibratoire

Schwingungdämpfender Schwermetallhalter

Low vibration heavy metal holders

L

710-NOVIBRA

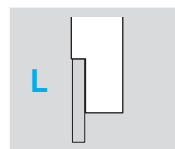
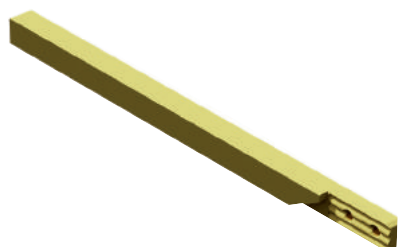

A x B	L	Serrage Spannsystem Clamping	Art. N°
6 x 6	115	A	710-6-NOVIBRA
7 x 7	115	A	710-7-NOVIBRA
8 x 8	115	A	710-8-NOVIBRA

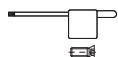

Chaque support est livré avec vis et clé.  
Jeder Halter wird mit Spannschraube(n) und Schlüssel geliefert.  
Screw(s) and key are included with each tool holder.

# TOP-WATCH

Plaquettes d'horlogerie pour machines à cames

Uhrenindustrie-WSP für kurvengesteuerte Maschinen

Watch industry inserts for cam driven machines

L

711SF / 712SF

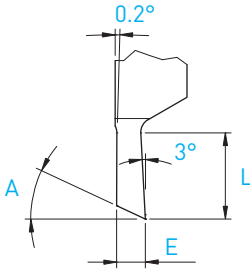
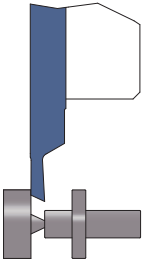

Tronçonnage  
Abstechen  
Parting off

E	L	A	Art. N°	HTC	HTC-RE	HTAF	HTiN	HN (µK10)
0.8	3.0	25°	711SF-0.8-25°	■	■	■	■	■
1.0	3.0	25°	711SF-1.0-25°	■	□	■	□	■

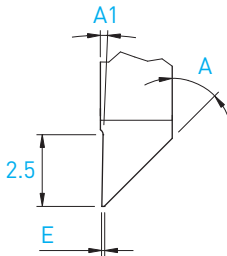
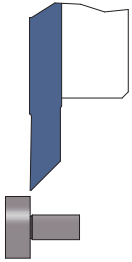

Tournage avant ébauche / finition  
Vorwärts drehen schruppen / schlichten  
Front turning for roughing / finishing

E	A	A1	Art. N°	HTC	HTC-RE	HTAF	HTiN	HN (µK10)
0.03	45°	3°	712SF-3/3-45°	■	□	■	□	■
0.08	45°	1°	712SF-8/8-45°	■	■	■	□	■

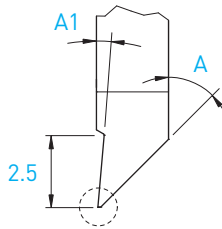
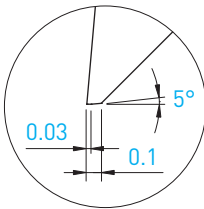
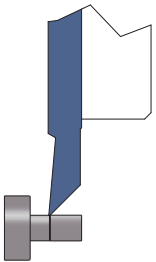

Tournage avant finition (pivotage)  
Vorwärts drehen schlichten  
Front turning for finishing

A	A1	Art. N°	HTC	HTC-RE	HTAF	HTiN	HN (µK10)
45°	3°	712SF-10/3	■	□	■	■	■

Plaquettes d'horlogerie pour machines à cames

Uhrenindustrie-WSP für kurvengesteuerte Maschinen

Watch industry inserts for cam driven machines

L

713SF

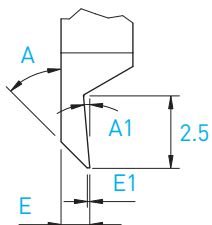
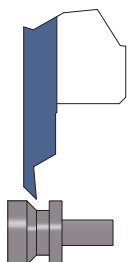

Tournage arrière ébauche / finition  
Rückwärts drehen schrappen / schlichten  
Back turning for roughing / finishing

E1	E	A	A1	Art. N°	HTC	HTC-RE	HTAF	HTiN	HN (μK10)
0.03	1.0	45°	5°	713SF-3/3-45°-1.0	■	□	□	□	■
0.10	1.0	45°	5°	713SF-10/10-45°-1.0	■	□	■	□	■

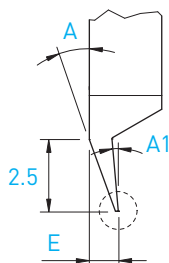
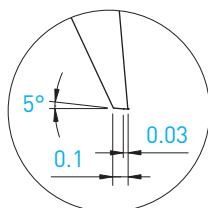
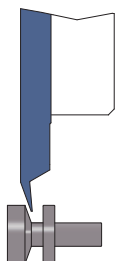

Tournage arrière finition  
Rückwärts drehen schlichten  
Back turning for finishing

E	A	A1	Art. N°	HTC	HTC-RE	HTAF	HTiN	HN (μK10)
1.0	20°	5°	713SF-10/3	■	□	■	■	■

Plaquettes ébauches

WSP-Rohlinge

Blank inserts

L

711-ESF

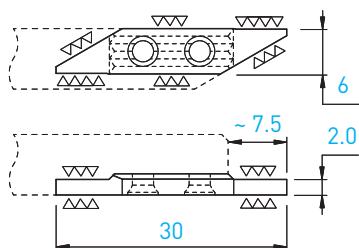

Art. N°	HTC	HTAF	HTiN	HN (μK10)	XN (μK01)	XTC	XTAF
711-ESF	■	■	□	■	■	■	■

Porte-outils

Halter

Holder

L/R

730 / 740

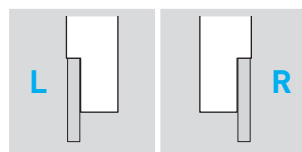
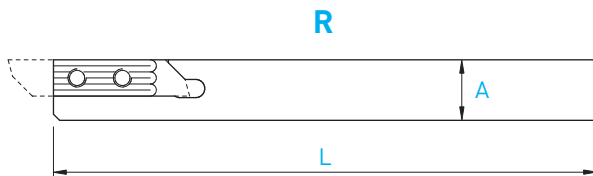
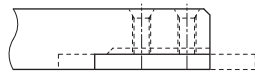
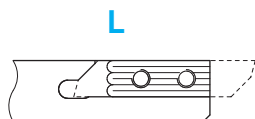

A x B	L	Serrage Spannsystem Clamping	Art. N°	Art. N°
7 x 7	115	A	<b>730-7</b>	<b>740-7</b>
8 x 8	115	A + B	<b>730-8</b>	<b>740-8</b>
8 x 8	140	A + B	<b>730-8-140</b>	-
10 x 10	115	A + B	<b>730-10</b>	<b>740-10</b>
12 x 12	130	A + B	<b>730-12</b>	<b>740-12</b>
12 x 12	90	A + B	<b>730-12-90</b>	<b>740-12-90</b>

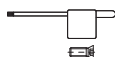

Chaque support est livré avec vis et clé.  
Jeder Halter wird mit Spannschraube(n) und Schlüssel geliefert.  
Screw(s) and key are included with each tool holder.

Porte-outils

Halter

Holder

R

740-SF

R

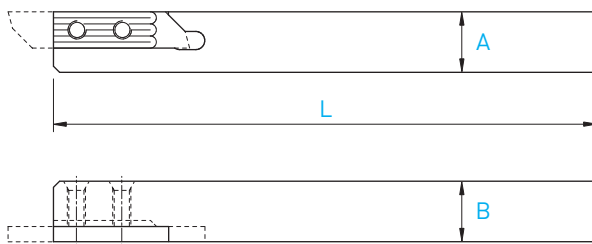

Super finition des 4 faces  
4 seitig feinstgeschliffen  
4 sides superfinish

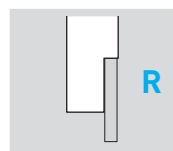

A x B	L	Serrage Spannsystem Clamping	Art. N°
7 x 7	90	A	740-7-90-SF
8 x 8	115	A + B	740-8-SF
8 x 8	90	A + B	740-8-90-SF
10 x 10	115	A + B	740-10-SF
10 x 10	90	A + B	740-10-90-SF
12 x 12	130	A + B	740-12-SF
12 x 12	90	A + B	740-12-90-SF

Porte-outils en métal lourd anti-vibratoire

Schwingungdämpfender Schwermetallhalter

Low vibration heavy metal holders

L/R

730 / 740-NOVIBRA

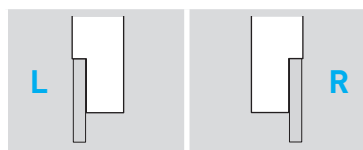

A x B	L	Serrage Spannsystem Clamping	Art. N°	Art. N°
7 x 7	115	A	730-7-NOVIBRA	740-7-NOVIBRA
8 x 8	115	A + B	730-8-NOVIBRA	740-8-NOVIBRA
8 x 8	80	A + B	-	740-8-80-NOVIBRA
10 x 10	115	A + B	-	740-10-NOVIBRA
12 x 12	130	A + B	-	740-12-NOVIBRA

Chaque support est livré avec vis et clé.  
Jeder Halter wird mit Spannschraube(n) und Schlüssel geliefert.  
Screw(s) and key are included with each tool holder.

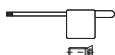

**new**

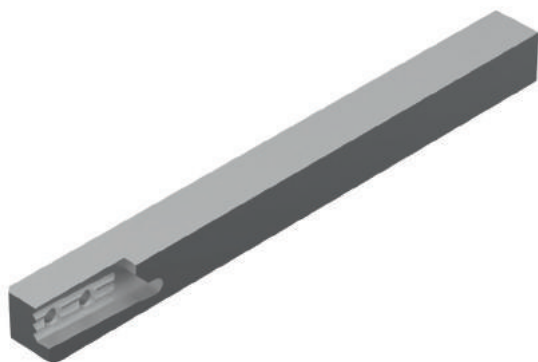
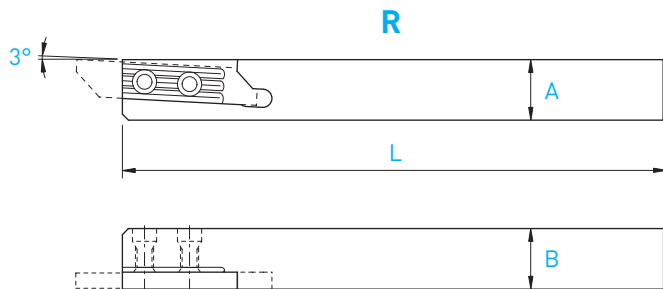

A x B	L	Serrage Spannsystem Clamping	Art. N°
8 x 8	115	A + B	<b>740X3-8-SF</b>
10 x 10	115	A + B	<b>740X3-10-SF</b>
12 x 12	130	A + B	<b>740X3-12-SF</b>



Plaquettes d'horlogerie pour machines CNC

Uhrenindustrie-WSP für CNC-Maschinen

Watch industry inserts for CNC machines

R

741SF / 742SF

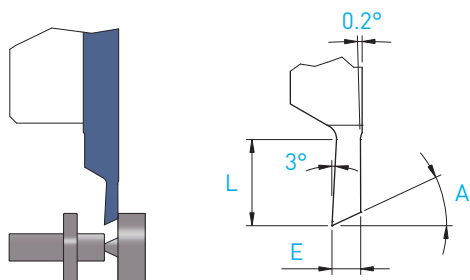

Tronçonnage  
Abstechen  
Parting off

E	L	A	Art. N°	HTC	HTC-RE	HTAF	HTAF-RE	HTAXF	HTAXF-RE	HTIN	HN (µK10)	XTAF	XTAXF	XTAXF-RE	XN (µK01)
0.5	2.0	25°	741SF-0.5-25°	■	□	■	□	■	□	□	■	■	■	□	□
0.8	3.0	25°	741SF-0.8-25°	■	□	■	□	■	□	□	■	■	■	□	□
1.0	3.0	25°	741SF-1.0-25°	■	□	■	□	■	□	□	■	■	■	□	□
1.2	6.0	22°	741SF-1.2-22°	■	□	■	□	■	□	□	■	■	■	□	□

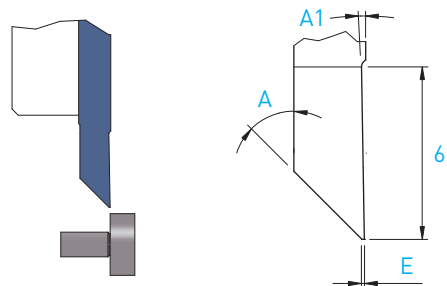

Tournage avant ébauche / finition  
Vorwärts drehen schrumpfen / schlichten  
Front turning for roughing / finishing

E	A	A1	Art. N°	HTC	HTC-RE	HTAF	HTAF-RE	HTAXF	HTAXF-RE	HTIN	HN (µK10)	XTAF	XTAXF	XTAXF-RE	XN (µK01)
0.03	45°	3°	742SF-3/3-45°	■	■	■	■	■	■	□	■	■	■	□	■
0.08	45°	1°	742SF-8/8-45°	■	■	■	■	■	■	□	■	■	■	□	■

■ = disponible / verfügbar / available  
□ = selon disponibilité du stock / jenach Lagerverfügbarkeit / depending on stock availability

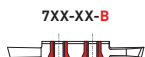

Sur demande pour serrage type B, voir page 2.25  
Wahlweise für B-Spannsystem, siehe Seite 2.25  
On request for B clamping system, see page 2.25

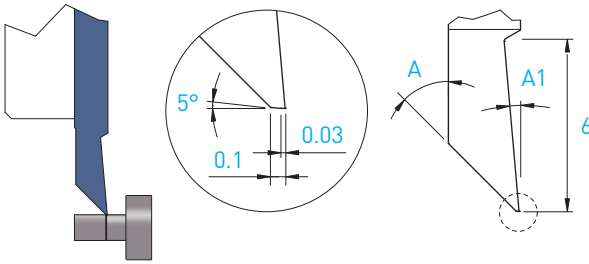

Tournage avant finition  
 Vorwärts drehen schlichten  
 Front turning for finishing

A	A1	Art. N°	HTC	HTC-RE	HTAF	HTAF-RE	HTAXF	HTAXF-RE	HTIN	HN (μK10)	XTAF	XTAXF	XTAXF-RE	XN (μK01)
45°	5°	742SF-10/3	■	■	■	□	□	□	■	■	■	■	□	□

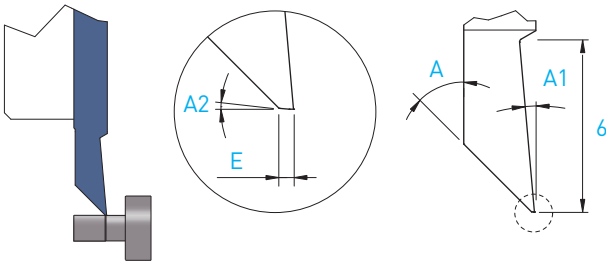

Tournage avant finition  
 Vorwärts drehen schlichten  
 Front turning for finishing

E	A	A1	A2	Art. N°	HTAF-RE	XTAF-RE
0.10	45°	5°	5°	742SF-10/0-5°-45°	■	■
0.15	30°	3°	2°	742SF-15/0-2°-30°	■	■

7XX-XX-B

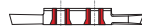

Sur demande pour serrage type B, voir page 2.25  
 Wahlweise für B-Spannsystem, siehe Seite 2.25  
 On request for B clamping system, see page 2.25

Plaquettes d'horlogerie pour machines CNC

Uhrenindustrie-WSP für CNC-Maschinen

Watch industry inserts for CNC machines

R

743SF

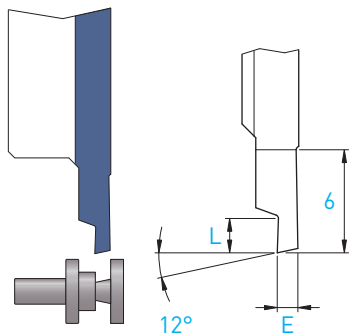

Tournage arrière ébauche  
Rückwärts drehen schrappen  
Back turning for roughing

E	L	Art. N°	HTC	HTAF	HN (µK10)
1.2	2.5	743SF-120/0-12°	■	■	■
1.4	3.0	743SF-140/0-12°	■	■	■
1.6	3.0	743SF-160/0-12°	■	■	■
1.8	4.0	743SF-180/0-12°	■	■	■

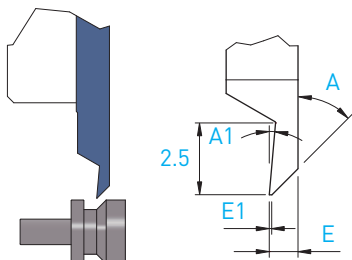

Tournage arrière ébauche/finition  
Rückwärts drehen schrappen/schlichten  
Back turning for roughing/finishing

E1	E	A	A1	Art. N°	HTC	HTC-RE	HTAF	HTAF-RE	HTAXF	HTAXF-RE	HTiN	HN (µK10)	XTAF	XTAXF	XTAXF-RE	XN (µK01)
0.03	1.0	45°	5°	743SF-3/3-45°-1.0	■	■	■	■	■	■	□	■	■	■	■	■
0.03	1.2	45°	5°	743SF-3/3-45°-1.2	■	■	■	■	■	■	□	■	■	■	■	■
0.10	1.0	45°	5°	743SF-10/10-45°-1.0	■	■	■	■	■	■	□	■	■	■	■	■
0.05	0.8	30°	3°	743SF-5/5-30°-0.8			■									
0.05	1.0	30°	3°	743SF-5/5-30°-1.0			■									

7XX-XX-B



Sur demande pour serrage type B, voir page 2.25  
Wahlweise für B-Spannsystem, siehe Seite 2.25  
On request for B clamping system, see page 2.25

■ = disponible / verfügbar / available  
□ = selon disponibilité du stock / jenach Lagerverfügbarkeit / depending on stock availability

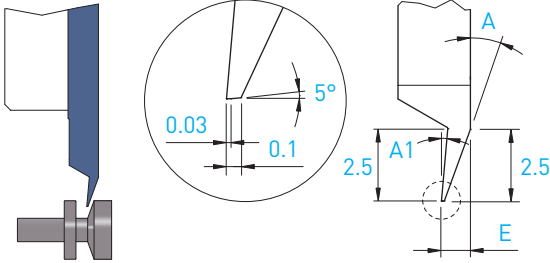

Tournage arrière finition  
 Rückwärts drehen schlichten  
 Back turning for finishing

E	A	A1	Art. N°	HTC	HTC-RE	HTAF	HTAF-RE	HTAXF	HTAXF-RE	HTIN	HN (µK10)	XTAF	XTAXF	XTAXF-RE	XN (µK01)
1.0	20°	5°	743SF-10/3	■	■	■	■	■	■	□	■	■	■	□	□

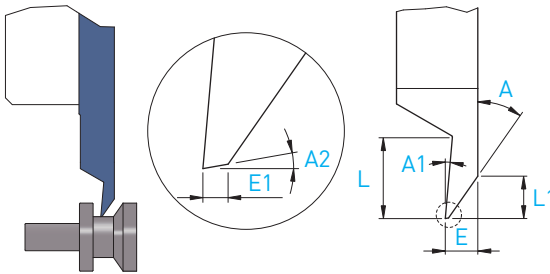

Tournage arrière finition  
 Rückwärts drehen schlichten  
 Back turning for finishing

E1	E	L1	L	A	A1	A2	Art. N°	HTAF-RE	XTAF-RE
0.08	1.0	1.6	2.5	30°	5°	2°	743SF-8/0-2°-30°-1.0	■	■
0.15	1.2	1.8	4.0	30°	3°	2°	743SF-15/0-2°-30°-1.2	■	■
0.10	1.0	1.3	2.5	35°	5°	10°	743SF-10/0-10°-35°-1.0	■	■

7XX-XX-B

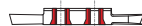

Sur demande pour serrage type B, voir page 2.25  
 Wahlweise für B-Spannsystem, siehe Seite 2.25  
 On request for B clamping system, see page 2.25

**Filetage à profil partiel – norme NIHS**

**Gewinde drehen mit Teilprofil – Norm NIHS**

**Threading with partial profile – norm NIHS**

R/L

746SF / 736SF

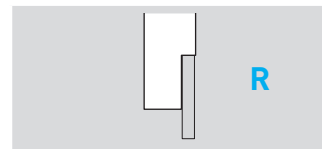
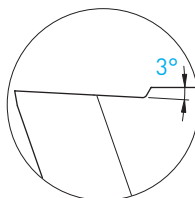
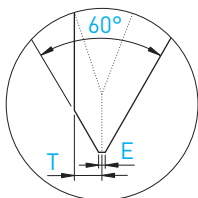
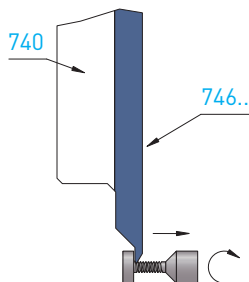

Filetage à droite  
sens rotation machine M3

Rechtgewinde Drehrichtung  
der Maschine M3

Right-hand thread rotating  
machinery M3

Filetage Gewinde drehen Threading	Pas Steigung Pitch P	T	E 0/-0.01	Art. N°	HTAF HN (µK10)
S0.50	0.125	0.07	0.015	746SFX3-A60-S0.50-AR	■ ■
S0.60	0.150	0.09	0.020	746SFX3-A60-S0.60-AR	■ ■
S0.70	0.175	0.10	0.020	746SFX3-A60-S0.70-AR	■ ■
S0.80	0.200	0.12	0.025	746SFX3-A60-S0.80-AR	■ ■
S0.90	0.225	0.13	0.030	746SFX3-A60-S0.90-AR	■ ■
S1.00	0.250	0.15	0.035	746SFX3-A60-S1.00-AR	■ ■

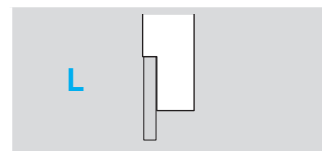
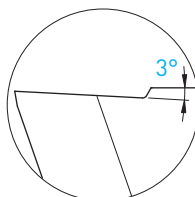
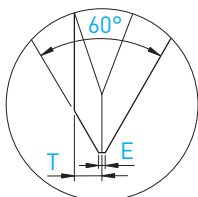
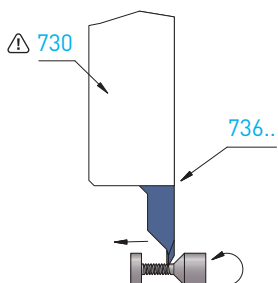

Filetage à droite  
sens rotation machine M4

Rechtgewinde Drehrichtung  
der Maschine M4

Right-hand thread rotating  
machinery M4

Filetage Gewinde drehen Threading	Pas Steigung Pitch P	T	E 0/-0.01	Art. N°	HTAF HN (µK10)
S0.50	0.125	0.07	0.015	736SFX3-A60-S0.50-AR	■ ■
S0.60	0.150	0.09	0.020	736SFX3-A60-S0.60-AR	■ ■
S0.70	0.175	0.10	0.020	736SFX3-A60-S0.70-AR	■ ■
S0.80	0.200	0.12	0.025	736SFX3-A60-S0.80-AR	■ ■
S0.90	0.225	0.13	0.030	736SFX3-A60-S0.90-AR	■ ■
S1.00	0.250	0.15	0.035	736SFX3-A60-S1.00-AR	■ ■

7XX-XX-B



Sur demande pour serrage type B, voir page 2.25  
Wahlweise für B-Spannsystem, siehe Seite 2.25  
On request for B clamping system, see page 2.25

■ = disponible / verfügbar / available  
□ = selon disponibilité du stock / jenach Lagerverfügbarkeit / depending on stock availability

# TOP-WATCH

Plaquettes piqure avant

Fronteinstich WSP

Front grooving inserts

R

748SF

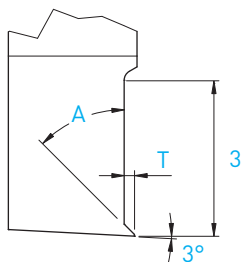
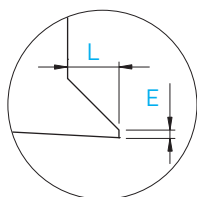
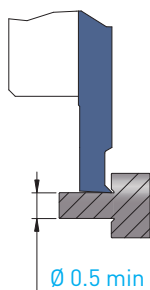

$E_{0/-0.01}$	A	T	Art. N°	HTC	HTC-RE	HTAF	HTAF-RE	HTIN	HN ( $\mu\text{K}10$ )
0.03	45°	0.2	748SF-E03-A45°-L20	■	■	■	■	□	■
0.05	45°	0.3	748SF-E05-A45°-L30	■	■	■	■	■	■
0.08	45°	0.5	748SF-E08-A45°-L50	■	■	■	■	□	■

Plaquettes piqure arrière

Rüceinstich WSP

Back grooving inserts

R

749SF

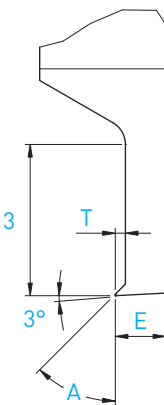
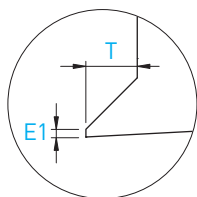
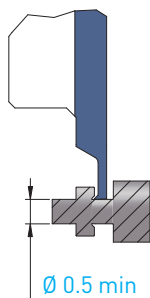

$E1_{0/-0.01}$	A	T	E	Art. N°	HTC	HTC-RE	HTAF	HTAF-RE	HTIN	HN ( $\mu\text{K}10$ )
0.03	45°	0.2	1.0	749SF-E03-A45°-L20-B100	■	■	■	■	□	■
0.05	45°	0.3	1.0	749SF-E05-A45°-L30-B100	■	□	■	■	□	■
0.08	45°	0.5	1.2	749SF-E08-A45°-L50-B120	■	■	■	■	□	■

7XX-XX-B



Sur demande pour serrage type B, voir page 2.25  
Wahlweise für B-Spannsystem, siehe Seite 2.25  
On request for B clamping system, see page 2.25

Plaquettes ébauches

WSP-Rohlinge

Blank inserts

L/R

731-ESF / 741-ESF

L

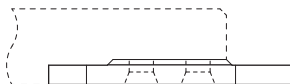
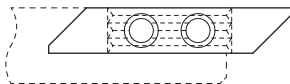

R

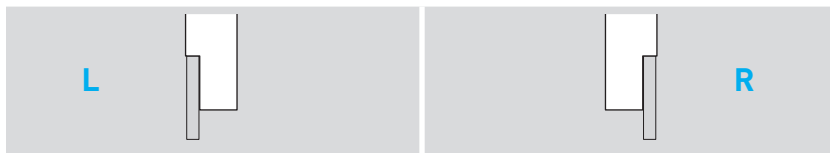
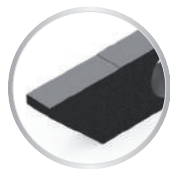
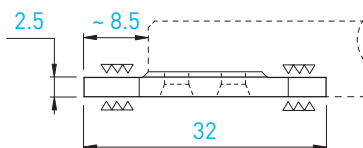
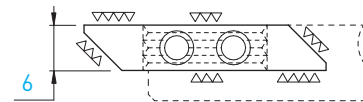

L				R													
Art. N°	HTC	HTAF	HTAXF	HTIN	HN (μK10)	XTC	XTAF	XN (μK01)	Art. N°	HTC	HTAF	HTAXF	HTIN	HN (μK10)	XTC	XTAF	XN (μK01)
731-ESF	■	■	■	■	■	■	■	■	741-ESF	■	■	■	■	■	■	■	■

7XX-XX-B



Sur demande pour serrage type B, voir page 2.25  
Wahlweise für B-Spannsystem, siehe Seite 2.25  
On request for B clamping system, see page 2.25

■ = disponible / verfügbar / available  
□ = selon disponibilité du stock / jenach Lagerverfügbarkeit / depending on stock availability

Porte-outils

Halter

Holder

Coupe à droite déportée

Versetztes Rechtsschneiden

Right cut off line

## 730RC / 750RC

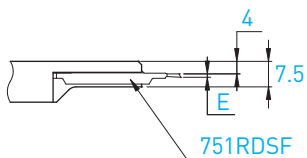
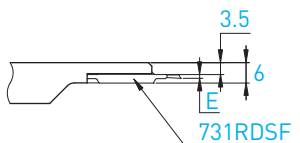
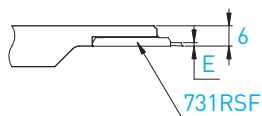
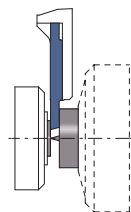

### L (R)

Coupe à droite déportée  
Versetztes Rechtsschneiden  
Right cut off line



A x B	L	L1	Art. N°
8 x 8	115	24	<b>730RC-8</b>
10 x 10	115	24	<b>730RC-10</b>
12 x 12	130	30	<b>730RC-12</b>
16 x 16	130	40	<b>730RC-16</b>

A x B	L	L1	Art. N°
12 x 12	130	30	<b>750RC-12</b>
16 x 16	130	40	<b>750RC-16</b>



Tronçonnage  
Abstechen  
Parting off

Coupe à droite déportée  
Versetztes Rechtsschneiden  
Right cut off line

731R / 751R

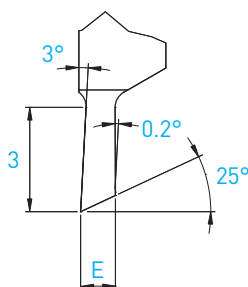
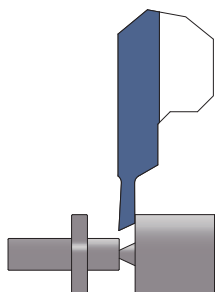

**L (R)**  
Coupe à droite déportée  
Versetztes Rechtsschneiden  
Right cut off line

E	Art. N°	HTAF	HTIN	HN (µK10)
1.0	731RSF-1.0-25°	■	■	■

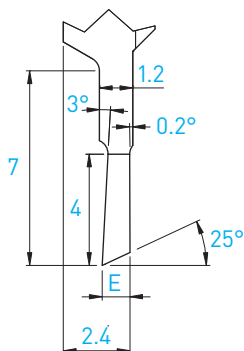
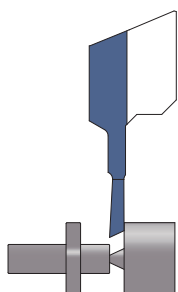

**L (R)**  
Coupe à droite déportée  
Versetztes Rechtsschneiden  
Right cut off line

E	Art. N°	HTAF	HTIN	HN (µK10)
0.8	731RDSF-0.8-25°	■	■	■
1.0	731RDSF-1.0-25°	■	□	■

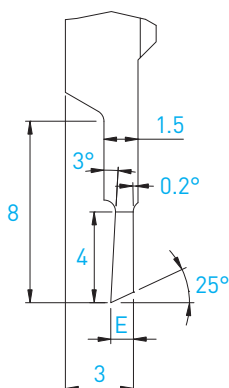
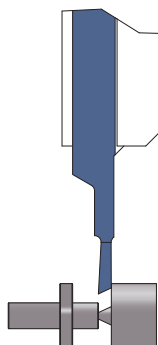

**L (R)**  
Coupe à droite déportée  
Versetztes Rechtsschneiden  
Right cut off line

E	Art. N°	HTAF	HTIN	HN (µK10)
0.8	751RDSF-0.8-25°	■	■	■
1.0	751RDSF-1.0-25°	■	□	■

■ = disponible / verfügbar / available  
□ = selon disponibilité du stock / jenach Lagerverfügbarkeit / depending on stock availability

**new**

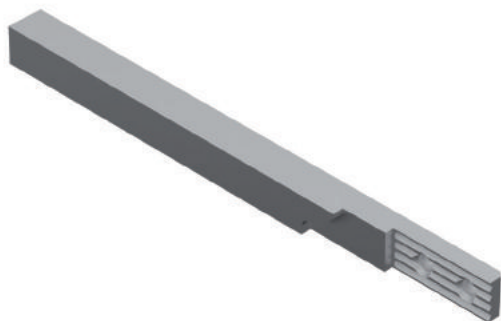
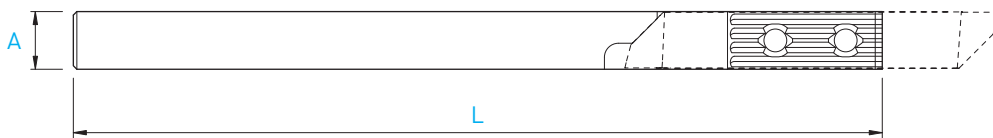

**L (R)**

Coupe à droite déportée  
Versetzttes Rechtsschneiden  
Right cut off line



A x B	L	Art. N°
8.2 x 8	115	770-8.2X8-SN4-SF

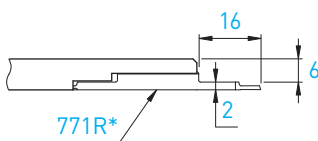
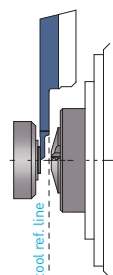
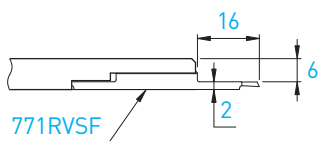
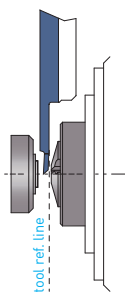

\* voir TOP-Line  
\* siehe TOP-Line  
\* see TOP-Line

Porte-outils

Halter

Holders

SwissNANO 7

770-SN7-SF

new

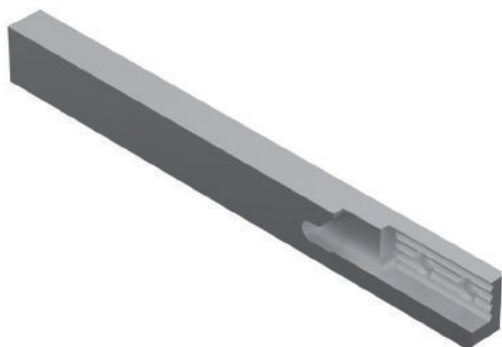
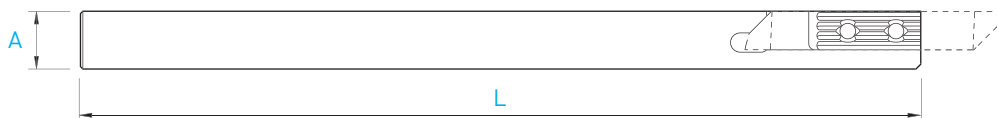

L (R)

Coupe à droite déportée  
Versetzttes Rechtsschneiden  
Right cut off line



A x B	L	Art. N°
12 x 8	115	770-12X8-SN7-SF

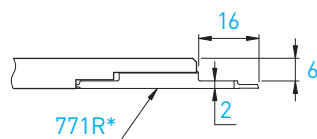
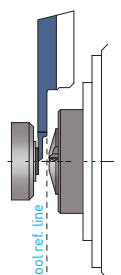
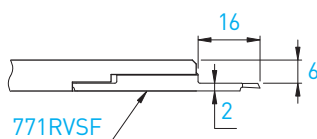
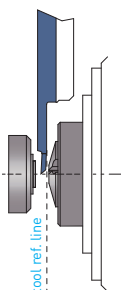

\* voir TOP-Line  
\* siehe TOP-Line  
\* see TOP-Line

Plaquette

Wendplatte

Insert

Coupe à gauche déportée

Versetztes Linksschneiden

Left cut off line

**new**

## 771RVSF

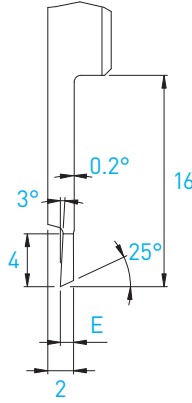
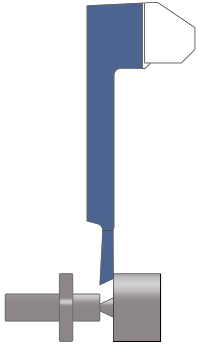

R (L)

Coupe à gauche déportée  
Versetztes Linksschneiden  
Left cut off line

E	Art. N°	TAF	N (µK20)
1.0	771RVSF-1.0-25°	■	■
1.2	771RVSF-1.2-25°	■	■
1.5	771RVSF-1.5-25°	■	■

Porte-outils spéciaux de tronçonnage

Sonder Abstechwerkzeughalter

Special parting off tool holders

## MODU-LINE

## ML12

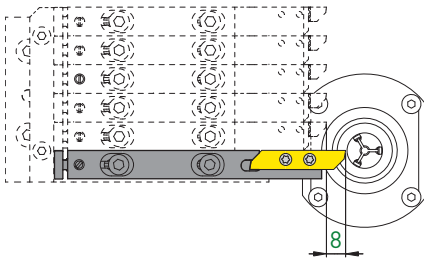

Type de machine Maschinen-Typ Type of machine	Porte-outils Halter Holders	Art. N°	Plaquettes type WSP Typ Inserts type
SwissNano	ML12	<b>ML12A-730RC-SWISS-NANO</b>	731RSF / 731RDSF
SwissNano	ML12	<b>ML12A-750RC-SWISS-NANO</b>	751RDSF

Voir documentation MODU-Line  
Siehe MODU-Line Dokumentation  
See MODU-Line documentation

L'outil de référence pour le décolletage

Hochwertiges Wendeplattensystem für Langdrehautomaten

Top class turning tool for automatic lathes

700 Series

## 100% rigid!

Système de serrage Applitec à denture décalée  
 Applitec-Spannsystem mit verschobener Verzahnung  
 Applitec clamping system with shifted teeth

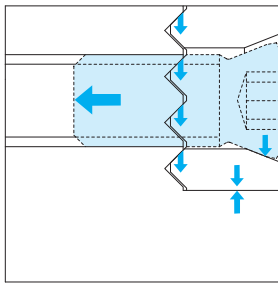
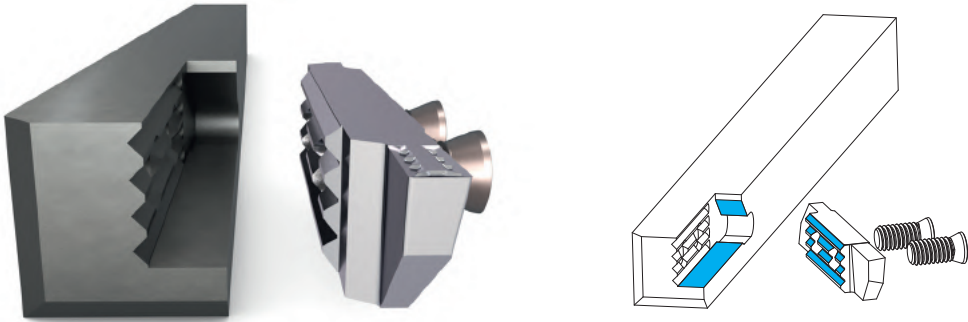

**Serrage standard (A)**  
**Standard Spannsystem (A)**  
**Standard clamping system (A)**

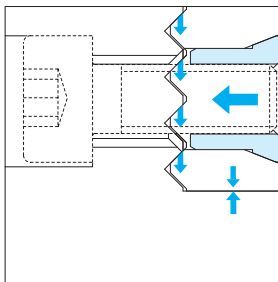
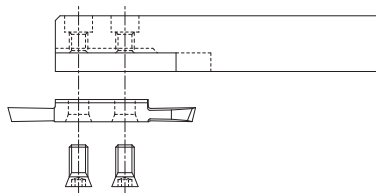

**Serrage type B\***  
**Spannsystem Typ B\***  
**Clamping system type B\***

ajouter -B après le numéro d'article  
 -B nach der Artikelreferenz hinzufügen  
 add -B after the article number

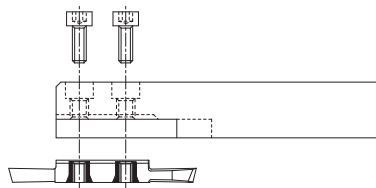

Changement de la plaquette possible dans la machine, sans démontage du porte-outil  
 WSP-Austauschmöglichkeit in der Maschine ohne Halterausbau  
 The insert can be changed in the machine without removing the tool holder

APPLITEC

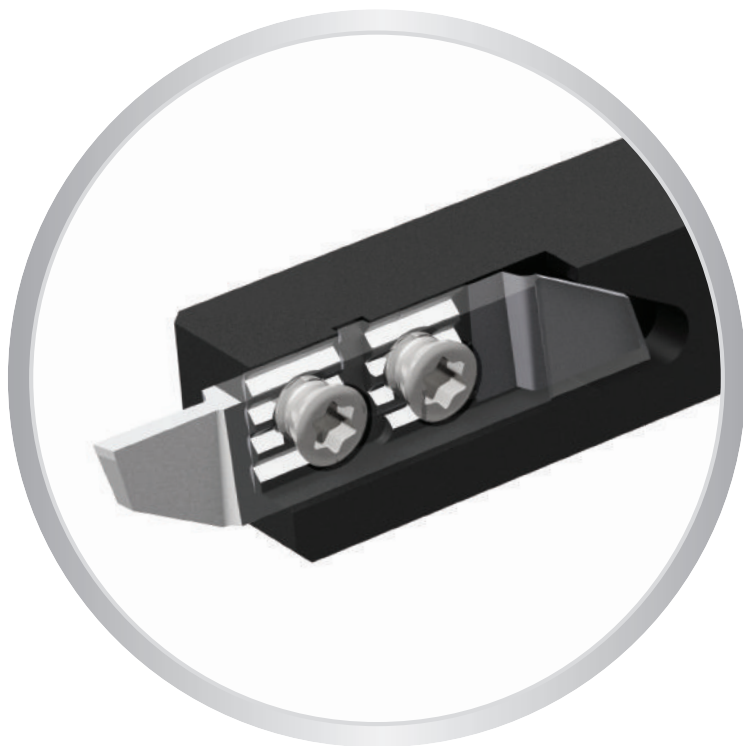









**INFO**

Codification Bezeichnungsschlüssel Designation key	Paramètres de coupe indicatifs Empfohlene Schnittwerte Standard machining data	Nuances Sorten Grades	> <b>3.02</b>
--	--	-----------------------------	---------------

**SERIES  
630 / 640**

Tournage  
et gorge  
  
Drehen und  
Einstechen  
  
Turning and  
grooving

Porte-outils Halter Holders		<b>630 / 640</b>	> <b>3.06</b>
Tournage avant Vorwärts drehen Front turning		<b>632 / 642</b>	> <b>3.08</b>
Tournage arrière Rückwärts drehen Back turning		<b>633 / 643</b>	> <b>3.11</b>
Fonçage-tournage Einstechen und drehen Grooving and turning		<b>634 / 644</b>	> <b>3.19</b>
Chanfreinage Anfasen Chamfering		<b>635 / 645</b>	> <b>3.24</b>
Filetage Gewinde drehen Threading		<b>636 / 646</b>	> <b>3.26</b>
Plaquettes à rayon Radius Wendepplatten Radius inserts		<b>637 / 647</b>	> <b>3.28</b>
Plaquettes ébauches WSP-Rohlinge Blank inserts		<b>631-EP / 641-EP</b>	> <b>3.30</b>

**SERIES  
650 / 660**

Tronçonnage  
  
Abstechen  
  
Parting off

Porte-outils Halter Holders		<b>650 / 660</b>	> <b>3.31</b>
Tronçonnage Abstechen Parting off		<b>651 / 661</b>	> <b>3.34</b>
Tronçonnage - coupe déportée Abstechen - versetztes Schneiden Parting off - cut off line		<b>651R</b>	> <b>3.39</b>
Plaquettes ébauches WSP-Rohlinge Blank inserts		<b>651-EP / 661-EP</b>	> <b>3.44</b>

Pièces de rechange et accessoires Ersatzteile und Zubehör Spare parts and accessories	> <b>3.45</b>
---	---------------

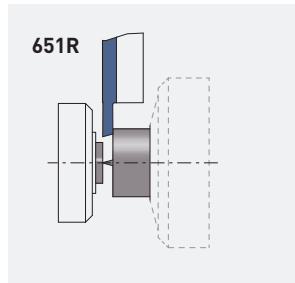
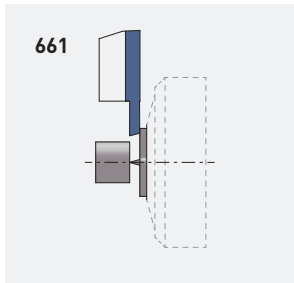
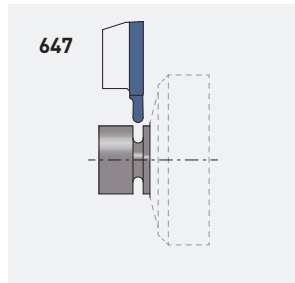
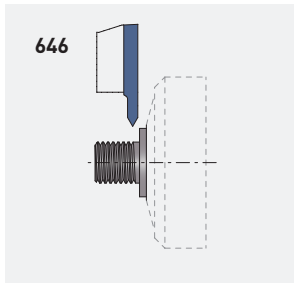
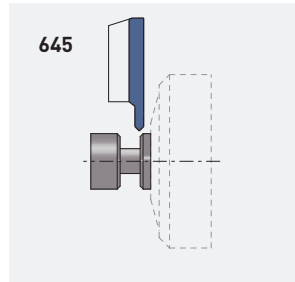
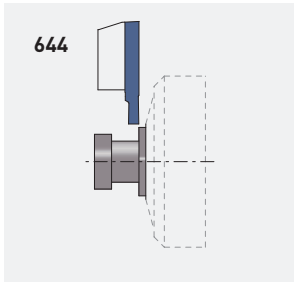
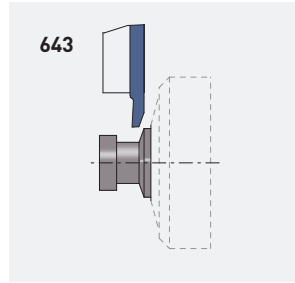
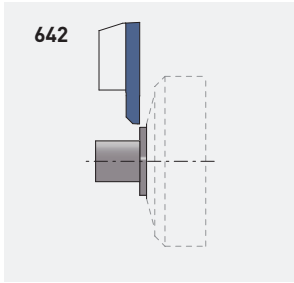



Codification des plaquettes PRO-Line série 600

WSP-Bezeichnungssystem für PRO-Line 600 Serie

Inserts designation key for PRO-Line 600 series

INFO



Dimension  
Abmessung  
Dimension

Rayon  
Radius  
Radius

Nuance  
Sorte  
Grade

Géométrie de coupe  
Schneidgeometrie  
Cutting geometry

brise-copeau  
Spanbrecher  
chip breaker

particularités  
Sondereigenschaften  
special features

Géométrie d'usinage  
Bearbeitungsgeometrie  
Machining geometry

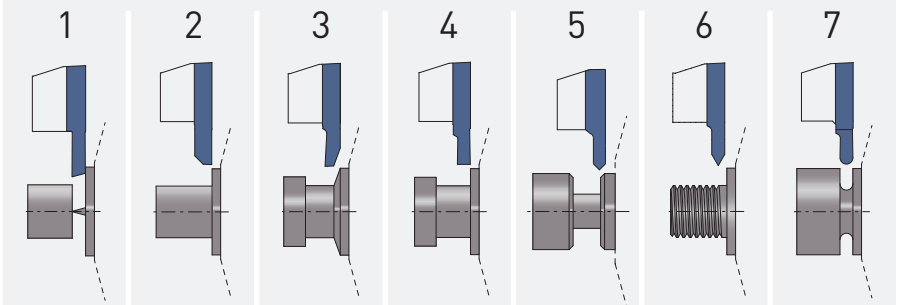

Gamme de produit  
Produktserie  
Product series

définit la compatibilité des plaquettes avec le porte-outil  
bestimmt die WSP und Halter Kompatibilität  
shows the inserts and holder compatibility

L = 3, 5

(chiffre impair / ungerade Zahl / uneven number)

R = 4, 6

(chiffre pair / gerade Zahl / even number)

SERIES

Tournage  
et gorge

L 630 | R 640

Drehen und  
Einstechen  
Turning and  
grooving



W max = 3 mm  
L max = 8 mm

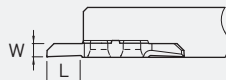

SERIES

Tronçonnage  
Abstechen  
Parting off

L 650 | R 660

W max = 2.5 mm  
L max = 11 mm

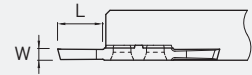

Applitec série 600  
Applitec 600 Serie  
Applitec 600 series

Système de serrage à denture avec 2 vis de fixation  
Spannsystem mit Verzahnung und 2 Schrauben  
Teeth clamping system with 2 screws

## Paramètres de coupe indicatifs

## Empfohlene Schnittwerte

## Standard machining data

Matière Werkstoff Material	Tournage Drehen Turning			Tronçonnage Abstechen Parting off		
	VC	630/640		VC	650/660	
		Prof. de passe Schnitttiefe Depth of cut	Avance Vorschub Feed		Largeur de coupe Abstechbreite Cutting width	Avance Vorschub Feed
(m/min)	(mm)	(mm/U)	(m/min)	(mm)	(mm/U)	
Acier de décolletage Automatenstahl Free-cutting steel	<b>P</b> 120 - 200	0.05 - 1.0 1.0 - 4.0	0.01 - 0.15 0.05 - 0.25	80 - 150	0.50 - 1.50 1.50 - 2.50	0.01 - 0.08 0.03 - 0.15
Acier Stahl < 600 N/mm <sup>2</sup> Steel	<b>P</b> 80 - 160	0.05 - 1.0 1.0 - 4.0	0.01 - 0.15 0.05 - 0.25	70 - 120	0.50 - 1.50 1.50 - 2.50	0.01 - 0.06 0.03 - 0.12
Acier Stahl < 800 N/mm <sup>2</sup> Steel	<b>P</b> 60 - 120	0.05 - 1.0 1.0 - 4.0	0.01 - 0.10 0.05 - 0.20	60 - 100	0.50 - 1.50 1.50 - 2.50	0.01 - 0.05 0.03 - 0.10
Acier Stahl > 800 N/mm <sup>2</sup> Steel	<b>P</b> 50 - 100	0.05 - 1.0 1.0 - 3.0	0.01 - 0.08 0.05 - 0.15	40 - 80	0.50 - 1.50 1.50 - 2.50	0.01 - 0.04 0.03 - 0.08
Acier inoxydable Rostfreistahl Stainless steel	<b>M</b> 60 - 120	0.05 - 1.0 1.0 - 3.0	0.01 - 0.08 0.05 - 0.15	60 - 100	0.50 - 1.50 1.50 - 2.50	0.01 - 0.04 0.03 - 0.08
Aluminium Si <12%	<b>N</b> 200 - 1000	0.05 - 1.0 1.0 - 4.0	0.01 - 0.20 0.05 - 0.40	180 - 400	0.50 - 1.50 1.50 - 2.50	0.01 - 0.10 0.03 - 0.20
Aluminium Si >12%	<b>N</b> 180 - 800	0.05 - 1.0 1.0 - 4.0	0.01 - 0.20 0.05 - 0.40	150 - 300	0.50 - 1.50 1.50 - 2.50	0.01 - 0.10 0.03 - 0.20
Cuivre, laiton, bronze Kupfer, Messing, Bronze Copper, brass, bronze	<b>N</b> 100 - 500	0.05 - 1.0 1.0 - 4.0	0.01 - 0.20 0.05 - 0.35	100 - 300	0.50 - 1.50 1.50 - 2.50	0.01 - 0.10 0.03 - 0.20
Titane Titan Titanium	<b>S</b> 30 - 70	0.05 - 1.0 1.0 - 4.0	0.01 - 0.08 0.05 - 0.15	30 - 50	0.50 - 1.50 1.50 - 2.50	0.01 - 0.03 0.03 - 0.06

Nuances

Sorten

Grades

### TiAlN

μK20 + revêtement PVD  
μK20 + PVD Beschichtung  
μK20 + PVD coating

- excellente nuance universelle
- 1<sup>er</sup> choix pour l'usinage des aciers, aciers inoxydables et alliages de titane
- très bonne résistance à la température

- beste Universalsorte
- für die Bearbeitung von Stahl, rostfreiem Stahl und Titanlegierungen bestens geeignet
- sehr gute Warmfestigkeit

- best universal grade
- first choice for steel, stainless steel and titanium alloys machining
- very good heat resistance

### N (μK20)

non revêtu  
unbeschichtet  
uncoated

- nuance micro-grain tenace
- supporte les coupes interrompues et autres conditions d'usinage défavorables

- zähe Feinkornsorte
- für unterbrochene Schnitte und andere ungünstige Bearbeitungsbedingungen geeignet

- tough micro-grain grade
- suitable for interrupted cut and other unfavorable machining conditions

### HTA

μK10 + revêtement PVD  
μK10 + PVD Beschichtung  
μK10 + PVD coating

- nuance très résistante à l'usure
- pour l'usinage en finition dans des conditions favorables des aciers, aciers inoxydables et alliages de titane

- sehr verschleissfeste Sorte
- für die Feinbearbeitung von Stahl, rostfreiem Stahl und Titanlegierungen bei guten Bearbeitungsbedingungen

- very wear resistant grade
- for light machining of steel, stainless steel and titanium alloys under favorable machining conditions

### HN (μK10)

non revêtu  
unbeschichtet  
uncoated

- nuance micro-grain très résistante à l'usure
- recommandé pour l'usinage du titane faiblement allié
- déconseillé en cas de coupe interrompue et autres conditions d'usinage défavorables

- verschleissfeste Feinkornsorte
- für die Bearbeitung von niedrig legiertem Titan empfehlenswert
- für unterbrochene Schnitte und andere ungünstige Bearbeitungsbedingungen nicht geeignet

- wear resistant micro-grain grade
- suitable for the machining of low alloyed titanium
- not suitable for interrupted cut and other unfavorable machining conditions

L

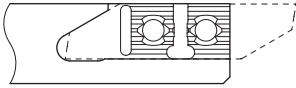

R

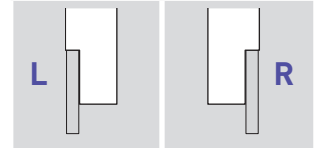
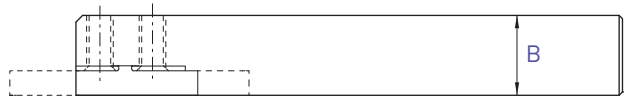
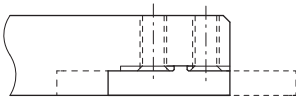
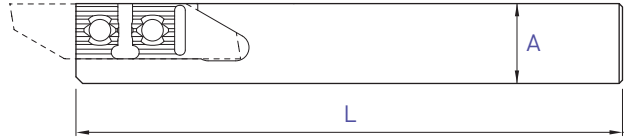

A x B	L	Art. N°	Art. N°
8 x 8	115	<b>630-8</b>	<b>640-8</b>
10 x 10	115	<b>630-10</b>	<b>640-10</b>
10 x 10	50	<b>630-10-50</b>	<b>640-10-50</b>
12 x 12	130	<b>630-12</b>	<b>640-12</b>
12 x 12	90	<b>630-12-90</b>	<b>640-12-90</b>
12.7 x 12.7	130	<b>630-12.7</b>	<b>640-12.7</b>
16 x 16	130	<b>630-16</b>	<b>640-16</b>
16 x 16	75	<b>630-16-75</b>	<b>640-16-75</b>
20 x 20	120	<b>630-20</b>	<b>640-20</b>

Chaque support est livré avec vis et clé.  
 Jeder Halter wird mit Spannschraube(n) und Schlüssel geliefert.  
 Screw(s) and key are included with each tool holder.

Porte-outils avec arrosage intégré  
 Halter mit integrierter Kühlmittelzufuhr  
 Holders with integrated coolant supply

630-JET / 640-JET

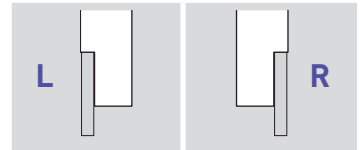
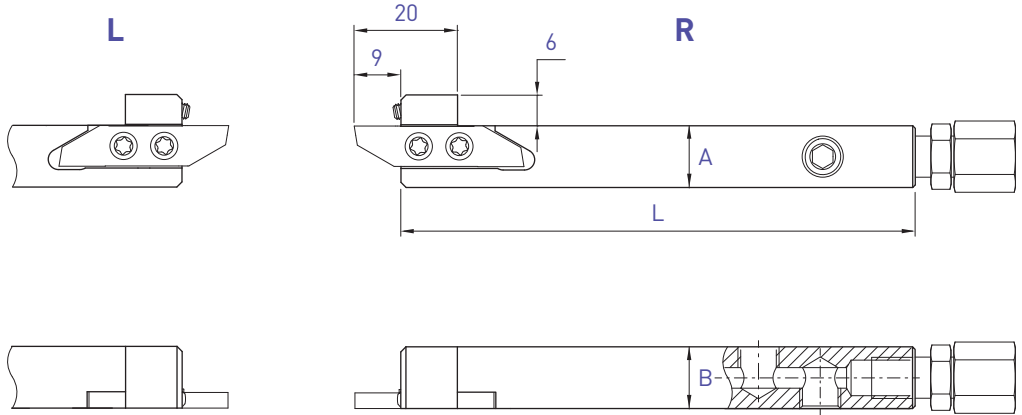

A x B	L	Art. N°	Art. N°
10 x 12	100	630-1012-JET	640-1012-JET
12 x 12	100	630-12-JET	640-12-JET
12.7 x 12.7	100	630-12.7-JET	640-12.7-JET
16 x 16	100	630-16-JET	640-16-JET
20 x 20	100	630-20-JET	640-20-JET

Chaque support est livré avec vis, clé, raccord droit et buse d'arrosage Ø 1.5 mm.  
 Jeder Halter wird mit Spannschraube(n), Schlüssel, gerader Kühlmittelanschluss und Kühlmitteldüse Ø 1.5 mm geliefert.  
 Screw(s), key, straight connector and coolant nozzle Ø 1.5 mm are included with each tool holder.

# PRO-LINE

Tournage avant  
Vorwärts drehen  
Front turning

632 / 642

L

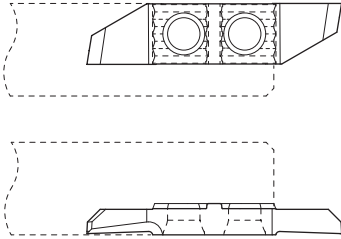

R

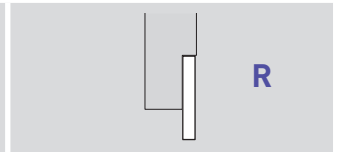
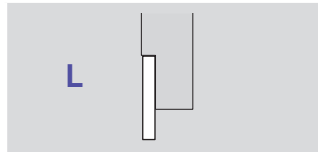
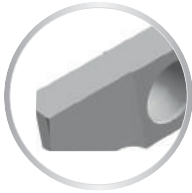
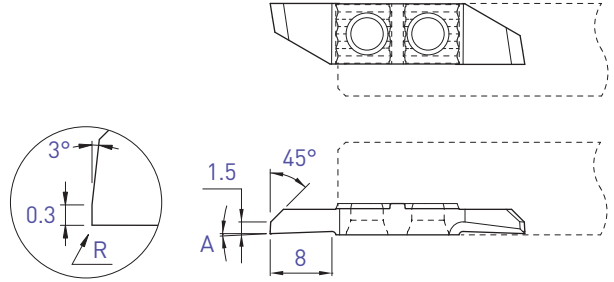

A	R	Art. N°	TiAlN N [µk20]	HTA HN [µk10]	Art. N°	TiAlN N [µk20]	HTA HN [µk10]
0°	0	632	■ ■		642	■ ■	□ □
0°	0.08	-			642-R08	■ ■	□ □
0°	0.15	-			642-R15	■ ■	□ □
2°	0	632-2°	■ ■		642-2°	■ ■	□ □
2°	0.08	-			642-2°-R08	■ ■	□ □
2°	0.15	-			642-2°-R15	■ ■	□ □

Tournage avant  
Vorwärts drehen  
Front turning

632X / 642X

L

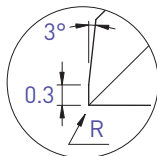
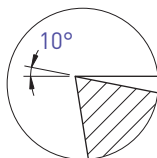
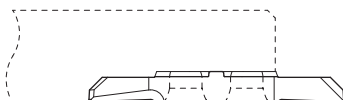
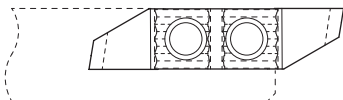

R

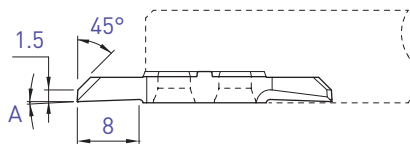
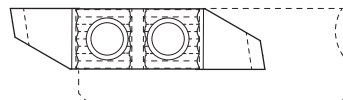

L

R

A	R	Art. N°	TiAlN N [µk20]	HTA HN [µk10]	Art. N°	TiAlN N [µk20]	HTA HN [µk10]
0°	0	632X10	■ ■		642X10	■ ■	□ □
0°	0.08	-			642X10-R08	■ ■	□ □
0°	0.15	-			642X10-R15	■ ■	□ □
2°	0	632X10-2°	■ ■		642X10-2°	■ ■	□ □
2°	0.08	-			642X10-2°-R08	■ ■	□ □
2°	0.15	-			642X10-2°-R15	■ ■	□ □

**Tournage multifonction**

**Mehrweck drehen**

**Multifunction turning**

**632S / 642S**

**L**

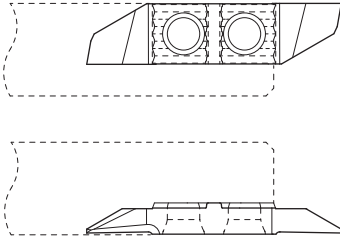

**R**

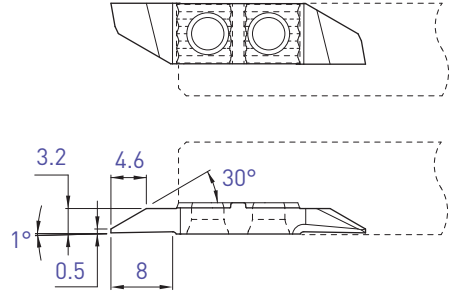

Tournage avant  
Vorwärts drehen  
Front turning

L				R			
Art. N°	TiAlN N (µk20)	HTA	HN (µk10)	Art. N°	TiAlN N (µk20)	HTA	HN (µk10)
632S05	■ ■			642S05	■ ■	□ □	



Tournage multifonction

Mehrweck drehen

Multifunction turning

633S / 643S

L

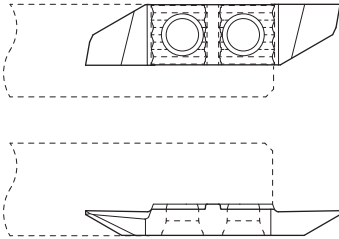

R

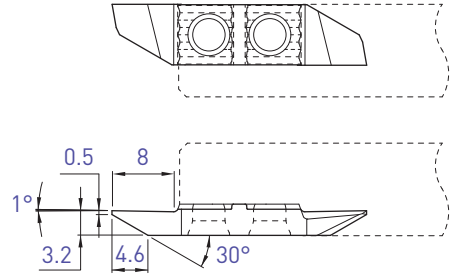

Tournage arrière  
Rückwärts drehen  
Back turning

L				R			
Art. N°	Ti/AlN N [µk20]	HTA	HN [µk10]	Art. N°	Ti/AlN N [µk20]	HTA	HN [µk10]
633S05	■ ■			643S05	■ ■	□ □	

L

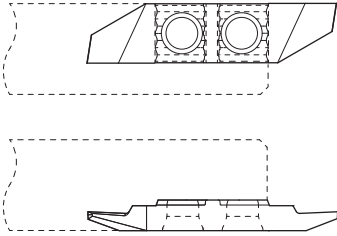

R

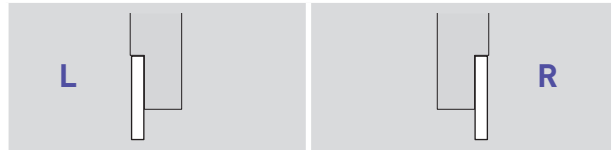
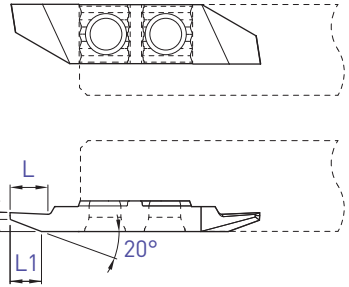

E1	E2	L	L1	E	R	Art. N°	TiAlN N (µk20)	HTA HN (µk10)	Art. N°	TiAlN N (µk20)	HTA HN (µk10)
0.5	0.25	3	2.8	1.5	0	633-0.5	■ ■		643-0.5	■ ■	□ □
0.5	0.25	3	2.8	1.5	0.08	-			643-0.5-R08	■ ■	□ □
0.8	0.40	4.5	3.3	2.0	0	-			643-0.8	■ ■	□ □
0.8	0.40	4.5	3.3	2.0	0.08	-			643-0.8-R08	■ ■	□ □
1.0	0.40	5	4.2	2.5	0	-			643-1.0	■ ■	□ □
1.0	0.40	5	4.2	2.5	0.08	-			643-1.0-R08	■ ■	□ □
1.5	0.50	6	4.2	3.0	0	-			643-1.5	■ ■	□ □
1.5	0.50	6	4.2	3.0	0.08	-			643-1.5-R08	■ ■	□ □

Tournage arrière  
 Rückwärts drehen  
 Back turning

633X / 643X

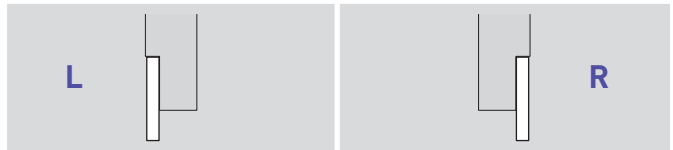
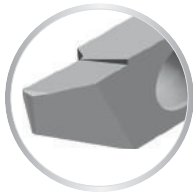
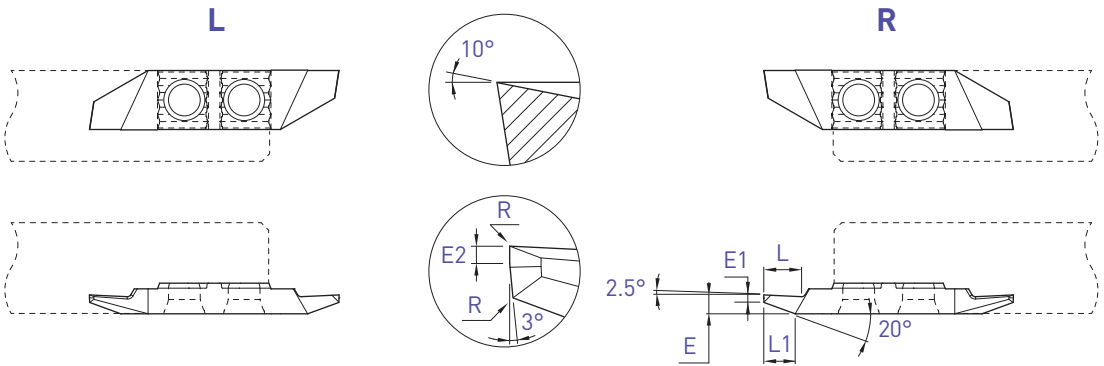

E1	E2	L	L1	E	R	Art. N°	TiAlN N (µk20)	HTA HN (µk10)	Art. N°	TiAlN N (µk20)	HTA HN (µk10)
0.5	0.25	3	2.8	1.5	0	633X10-0.5	■ ■		643X10-0.5	■ ■	□ □
0.5	0.25	3	2.8	1.5	0.08	-			643X10-0.5-R08	■ ■	□ □
0.8	0.40	4.5	3.3	2.0	0	-			643X10-0.8	■ ■	□ □
0.8	0.40	4.5	3.3	2.0	0.08	-			643X10-0.8-R08	■ ■	□ □
1.0	0.40	5	4.2	2.5	0	-			643X10-1.0	■ ■	□ □
1.0	0.40	5	4.2	2.5	0.08	-			643X10-1.0-R08	■ ■	□ □
1.5	0.50	6	4.2	3.0	0	-			643X10-1.5	■ ■	□ □
1.5	0.50	6	4.2	3.0	0.08	-			643X10-1.5-R08	■ ■	□ □

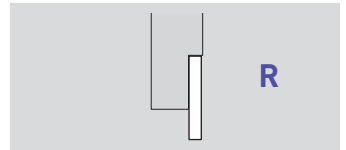
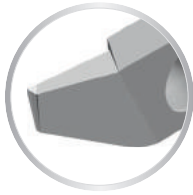
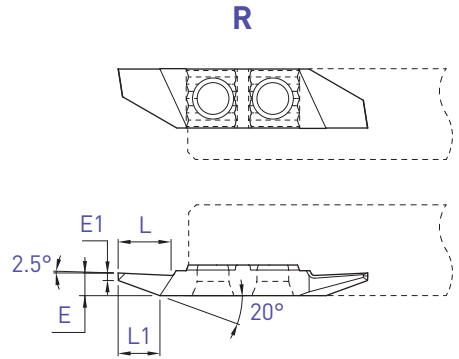
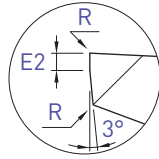
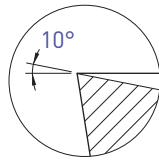

E1	E2	L	L1	E	R	Art. N°	TiAlN N [µk20]	HTA	HN [µk10]
1.0	0.4	7	5.5	3.0	0	643X10S-1.0	■ ■	□ □	
1.0	0.4	7	5.5	3.0	0.08	643X10S-1.0-R08	■ ■	□ □	

Tournage arrière  
 Rückwärts drehen  
 Back turning

643VX8

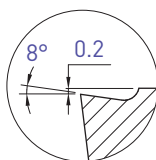

R

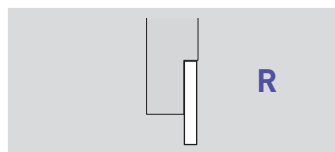
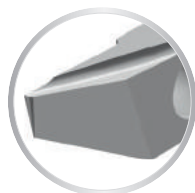
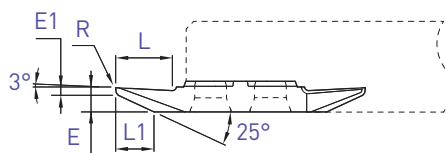
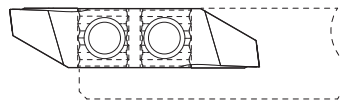

E1	L	L1	E	R	Art. N°	TiAlN N [µk20]	HTA	HN [µk10]
1.0	7.5	5.0	3.2	0	643VX8	■ ■	□ □	
1.0	7.5	5.0	3.2	0.08	643VX8-R08	■ ■	□ □	

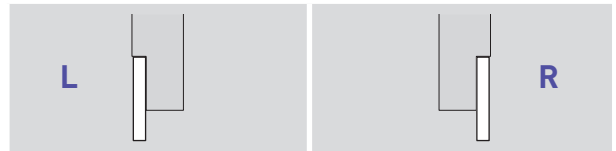
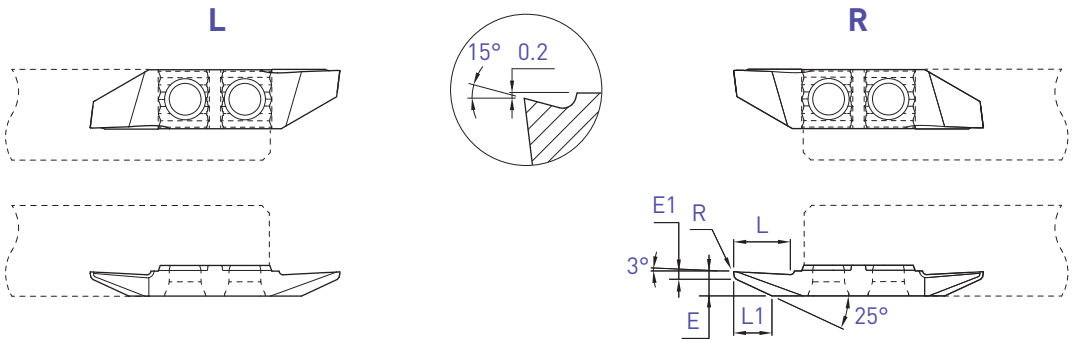

E1	L	L1	E	R	Art. N°	TiAlN N [µk20]	HTA HN [µk10]	Art. N°	TiAlN N [µk20]	HTA HN [µk10]
0.6	7.5	5.2	3.2	0	633VX15	■ ■		643VX15	■ ■	□ □
0.6	7.5	5.2	3.2	0.08	-			643VX15-R08	■ ■	□ □

Tournage arrière  
 Rückwärts drehen  
 Back turning

643VUX

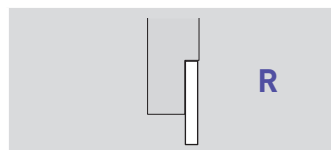
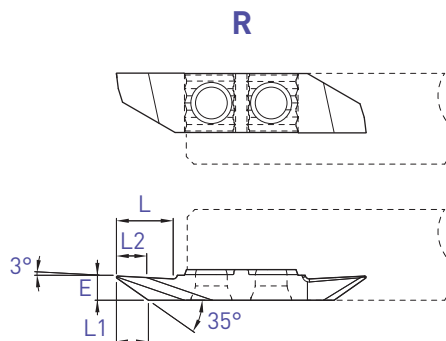
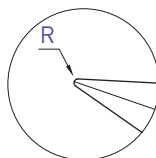
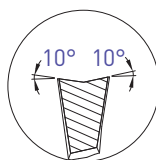

L	L1	L2	E	R	Art. N°	TiAlN N [µk20]	HTA	HN [µk10]
7.5	4.2	4.0	3.2	0.15	643VUX10-R15	■ ■	□ □	
7.5	3.8	3.8	3.2	0.35	643VUX10-R35	■ ■	□ □	

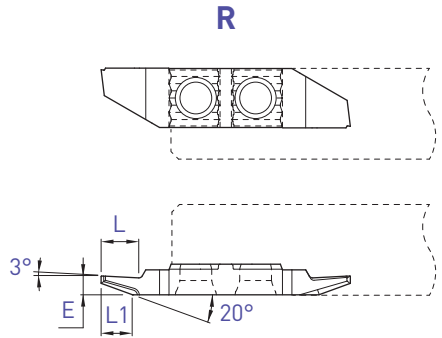
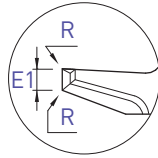
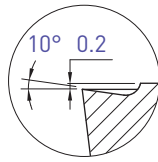

Pour un meilleur contrôle des copeaux  
Für eine bessere Spankontrolle  
For a better chip control

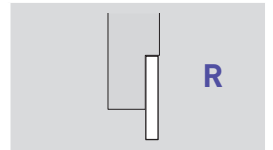

E1	L	L1	E	R	Art. N°	TiAlN N (µk20)
1.0	5	4	2.5	0.01	643ZX10-1.0	■
1.0	5	4	2.5	0.08	643ZX10-1.0-R08	■

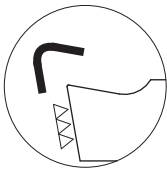

Arête de coupe honée  
Gehonte Schneidkante  
Honed edge

f min: 0.02 mm/U



Fonçage-tournage

Einstecken und drehen

Grooving and turning

634 / 644

L

R

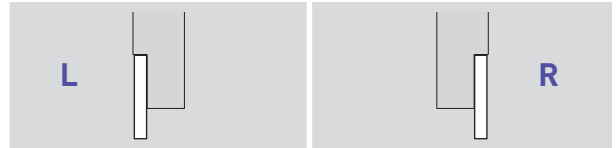
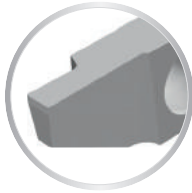
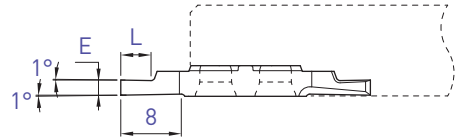
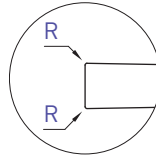
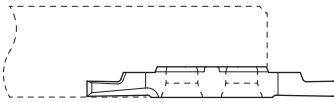
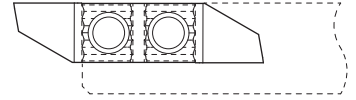
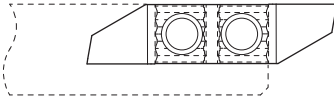

E	L	R	Art. N°	TiAlN N (µk20)	HTA HN (µk10)	Art. N°	TiAlN N (µk20)	HTA HN (µk10)
0.5	1.5	0	634-0.5	■ ■		644-0.5	■ ■	□ □
0.6	1.8	0	-			644-0.6	■ ■	□ □
0.75	2	0	-			644-0.75	■ ■	□ □
0.8	2	0	634-0.8	■ ■		644-0.8	■ ■	□ □
0.9	2.5	0	-			644-0.9	■ ■	□ □
0.95	3	0	-			644-0.95	■ ■	□ □
1.0	2.5	0	634-1.0	■ ■		644-1.0	■ ■	□ □
1.0	2.5	0.08	-			644-1.0-R08	■ ■	□ □
1.2	3	0	634-1.2	■ ■		644-1.2	■ ■	□ □
1.2	3	0.08	-			644-1.2-R08	■ ■	□ □
1.5	3	0	634-1.5	■ ■		644-1.5	■ ■	□ □
1.5	3	0.08	-			644-1.5-R08	■ ■	□ □
1.5	3	0.15	-			644-1.5-R15	■ ■	□ □
1.8	4	0	-			644-1.8	■ ■	□ □
2.0	4	0	634-2.0	■ ■		644-2.0	■ ■	□ □
2.0	4	0.08	-			644-2.0-R08	■ ■	□ □
2.0	4	0.15	-			644-2.0-R15	■ ■	□ □
2.5	6	0	634-2.5	■ ■		644-2.5	■ ■	□ □
2.5	6	0.08	-			644-2.5-R08	■ ■	□ □
2.5	6	0.15	-			644-2.5-R15	■ ■	□ □
3	6	0	634-3.0	■ ■		644-3.0	■ ■	□ □
3	6	0.08	-			644-3.0-R08	■ ■	□ □
3	6	0.15	-			644-3.0-R15	■ ■	□ □

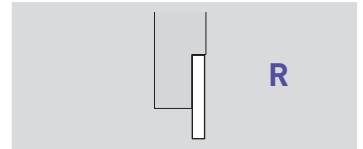
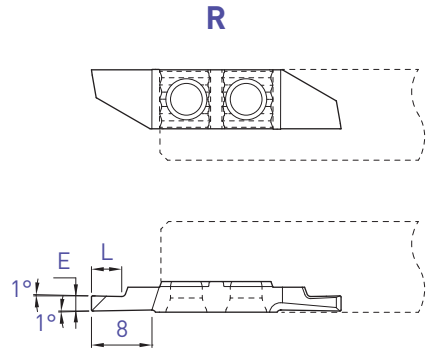
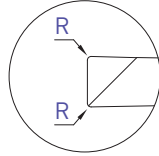
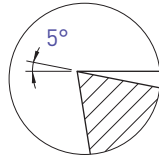

E	L	R	Art. N°	TiAlN	N (µk20)	HTA	HN (µk10)
1.5	3	0.08	644X5-1.5-R08	■	■	□	□
2	4	0.08	644X5-2.0-R08	■	■	□	□
2	4	0.15	644X5-2.0-R15	■	■	□	□
2.5	6	0.08	644X5-2.5-R08	■	■	□	□
2.5	6	0.15	644X5-2.5-R15	■	■	□	□
3	6	0.08	644X5-3.0-R08	■	■	□	□
3	6	0.15	644X5-3.0-R15	■	■	□	□

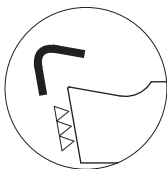
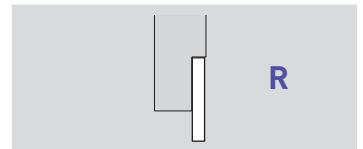

Arête de coupe honée  
 Gehonte Schneidkante  
 Honed edge

f min: 0.02 mm/U

E	L	R	Art. N°	TiAlN	N (µk20)	HTA	HN (µk10)
1.5	3	0.08	644X5-1.5-R08-EP	■	■		
2	4	0.08	644X5-2.0-R08-EP	■	■		
2	4	0.15	644X5-2.0-R15-EP	■	■		
2.5	6	0.08	644X5-2.5-R08-EP	■	■		
2.5	6	0.15	644X5-2.5-R15-EP	■	■		
3	6	0.08	644X5-3.0-R08-EP	■	■		
3	6	0.15	644X5-3.0-R15-EP	■	■		

Fonçage-tournage

Einstecken und drehen

Grooving and turning

634X10 / 644X10

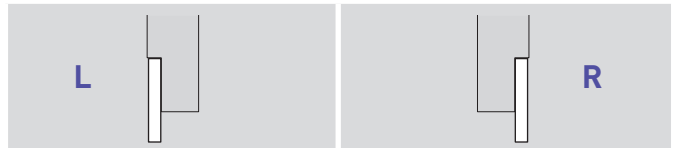
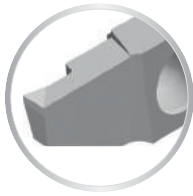
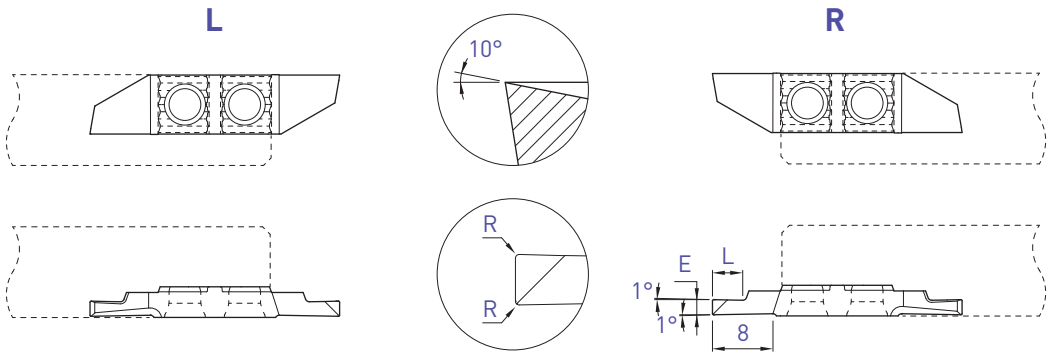

E	L	R	Art. N°	TiAlN		HTA		Art. N°	TiAlN		HTA	
				N (µk20)	HN (µk10)	N (µk20)	HN (µk10)		N (µk20)	HN (µk10)		
0.8	2	0	634X10-0.8	■	■			644X10-0.8	■	■	□	□
1.0	2.5	0	634X10-1.0	■	■			644X10-1.0	■	■	□	□
1.0	2.5	0.08	634X10-1.0-R08	■	■			644X10-1.0-R08	■	■	□	□
1.2	3	0	-					644X10-1.2	■	■	□	□
1.2	3	0.08	-					644X10-1.2-R08	■	■	□	□
1.5	3	0	634X10-1.5	■	■			644X10-1.5	■	■	□	□
1.5	3	0.08	634X10-1.5-R08	■	■			644X10-1.5-R08	■	■	□	□
1.5	3	0.15	634X10-1.5-R15	■	■			644X10-1.5-R15	■	■	□	□
1.8	4	0	-					644X10-1.8	■	■	□	□
2	4	0	634X10-2.0	■	■			644X10-2.0	■	■	□	□
2	4	0.08	634X10-2.0-R08	■	■			644X10-2.0-R08	■	■	□	□
2	4	0.15	634X10-2.0-R15	■	■			644X10-2.0-R15	■	■	□	□
2.5	6	0	634X10-2.5	■	■			644X10-2.5	■	■	□	□
2.5	6	0.08	634X10-2.5-R08	■	■			644X10-2.5-R08	■	■	□	□
2.5	6	0.15	634X10-2.5-R15	■	■			644X10-2.5-R15	■	■	□	□
3	6	0	634X10-3.0	■	■			644X10-3.0	■	■	□	□
3	6	0.08	634X10-3.0-R08	■	■			644X10-3.0-R08	■	■	□	□
3	6	0.15	634X10-3.0-R15	■	■			644X10-3.0-R15	■	■	□	□

■ = disponible / verfügbar / available  
 □ = selon disponibilité du stock / jenach Lagerverfügbarkeit / depending on stock availability

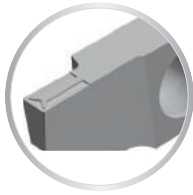
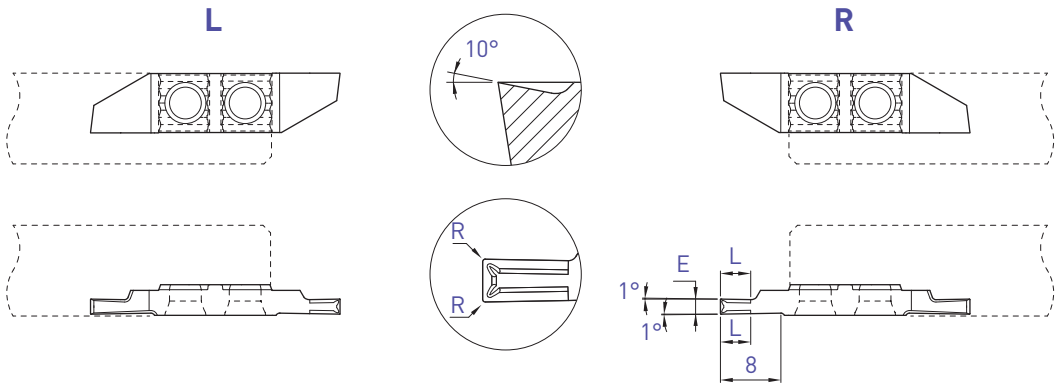

Pour un meilleur contrôle des copeaux  
Für eine bessere Spankontrolle  
For a better chip-control

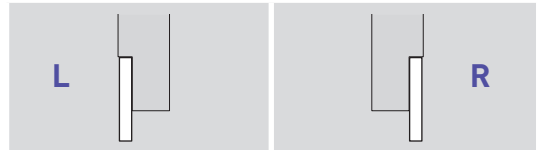

E	L	R	Art. N°	TiAlN N (µk20)	Art. N°	TiAlN N (µk20)
1.0	2.5	0.01	634ZXB10-1.0	■	644ZXB10-1.0	■
1.5	4	0.01	634ZXB10-1.5	■	644ZXB10-1.5	■
1.5	4	0.08	634ZXB10-1.5-R08	■	644ZXB10-1.5-R08	■
2.0	4	0.01	634ZXB10-2.0	■	644ZXB10-2.0	■
2.0	4	0.08	634ZXB10-2.0-R08	■	644ZXB10-2.0-R08	■
2.0	4	0.15	634ZXB10-2.0-R15	■	644ZXB10-2.0-R15	■
2.5	5	0.08	634ZXB10-2.5-R08	■	644ZXB10-2.5-R08	■
2.5	5	0.15	634ZXB10-2.5-R15	■	644ZXB10-2.5-R15	■
3.0	6	0.08	634ZXB10-3.0-R08	■	644ZXB10-3.0-R08	■
3.0	6	0.15	634ZXB10-3.0-R15	■	644ZXB10-3.0-R15	■
3.0	6	0.35	634ZXB10-3.0-R35	■	644ZXB10-3.0-R35	■

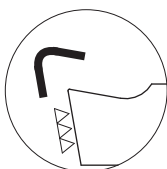

Arête de coupe honée  
Gehonte Schneidkante  
Honed edge

f min: 0.02 mm/U

Fonçage-tournage

Einstecken und drehen

Grooving and turning

634ZXT / 644ZXT

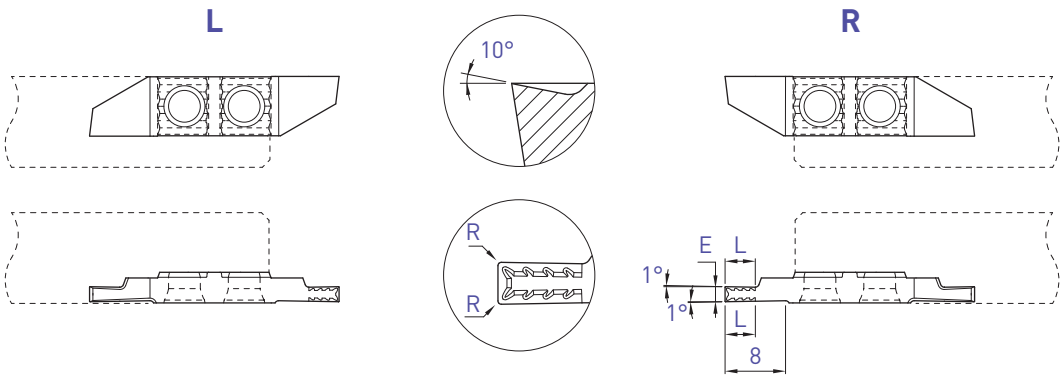

Pour un meilleur contrôle des copeaux  
Für eine bessere Spankontrolle  
For a better chip-control

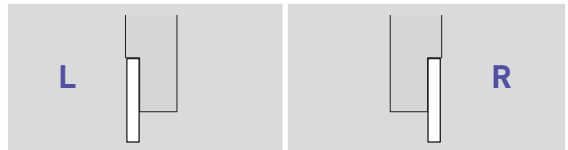

E	L	R	Art. N°	TiAlN N (µm20)	Art. N°	TiAlN N (µm20)
1.0	2.5	0.01	634ZXT10-1.0	■	644ZXT10-1.0	■
1.5	4	0.01	634ZXT10-1.5	■	644ZXT10-1.5	■
1.5	4	0.08	634ZXT10-1.5-R08	■	644ZXT10-1.5-R08	■
2.0	4	0.01	634ZXT10-2.0	■	644ZXT10-2.0	■
2.0	4	0.08	634ZXT10-2.0-R08	■	644ZXT10-2.0-R08	■
2.0	4	0.15	634ZXT10-2.0-R15	■	644ZXT10-2.0-R15	■
2.5	5	0.08	634ZXT10-2.5-R08	■	644ZXT10-2.5-R08	■
2.5	5	0.15	634ZXT10-2.5-R15	■	644ZXT10-2.5-R15	■
3.0	6	0.08	634ZXT10-3.0-R08	■	644ZXT10-3.0-R08	■
3.0	6	0.15	634ZXT10-3.0-R15	■	644ZXT10-3.0-R15	■
3.0	6	0.35	-		644ZXT10-3.0-R35	■



Arête de coupe honée  
Gehonte Schneidkante  
Honed edge

f min: 0.02 mm/U

Chanfreinage

Anfasen

Chamfering

635-90 / 645-90

L

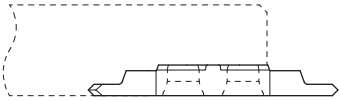
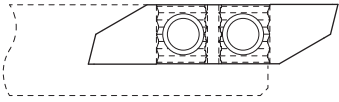

R

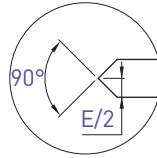
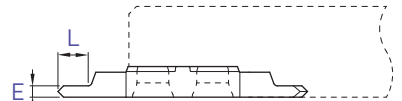
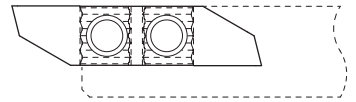

L

R

E	L	Art. N°	TiAlN N (µk20)	Art. N°	TiAlN N (µk20)
1.5	4	635-90-1.5	■ ■	645-90-1.5	■ ■

Chanfreinage

Anfasen

Chamfering

635X-90 / 645X-90

L

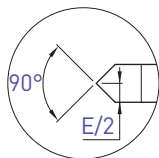
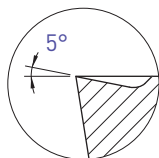
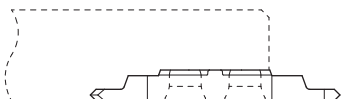
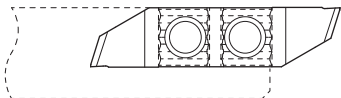

R

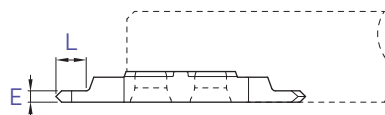
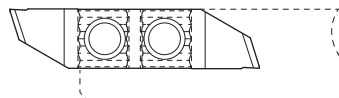

L



R



E	L	Art. N°	TiAlN N (µk<20)	Art. N°	TiAlN N (µk<20)
1.5	4	635X5-90-1.5	■ ■	645X5-90-1.5	■ ■

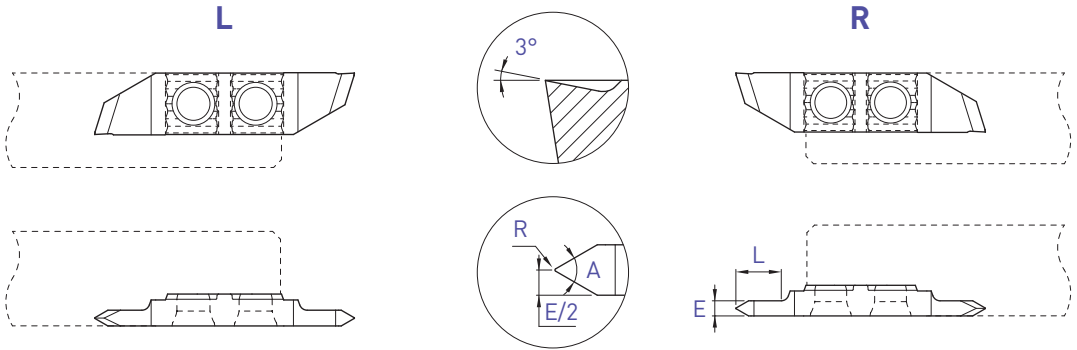

Profil partiel  
Teilprofil  
Partial profile



A	E	L	R	Art. N°	TiAlN N (µk20)	Art. N°	TiAlN N (µk20)
55°	1.5	4	0	636X3-55-1.5	■ ■	646X3-55-1.5	■ ■
55°	2.0	6	0.03	636X3-55-2.0-R03	■ ■	646X3-55-2.0-R03	■ ■
60°	1.5	4	0	636X3-60-1.5	■ ■	646X3-60-1.5	■ ■
60°	2.0	6	0.03	636X3-60-2.0-R03	■ ■	646X3-60-2.0-R03	■ ■
60°	2.0	6	0.06	636X3-60-2.0-R06	■ ■	646X3-60-2.0-R06	■ ■
60°	3.0	8	0.06	636X3-60-3.0-R06	■ ■	646X3-60-3.0-R06	■ ■
60°	3.0	8	0.12	636X3-60-3.0-R12	■ ■	646X3-60-3.0-R12	■ ■



Filetage

Gewinde drehen

Threading

636X-M / 646X-M

L

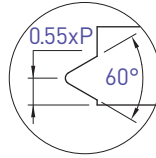
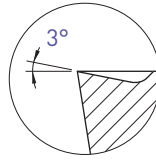
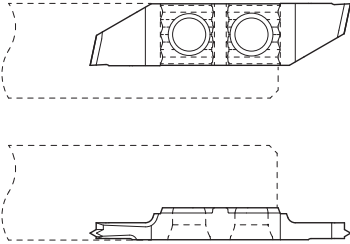

R

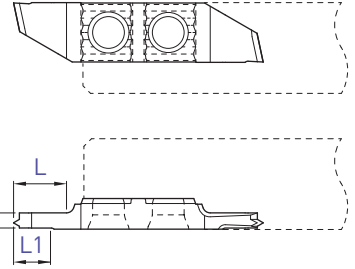

Profil complet métrique  
Metrisches Vollprofil  
Metric full profile

L



R



E	L	L1	Pas Steigung Pitch P	Art. N°	TiAlN N (µk20)	Art. N°	TiAlN N (µk20)
1.0	3	3	0.25	636X3-M-0.25	■ ■	646X3-M-0.25	■ ■
1.0	3	3	0.30	636X3-M-0.30	■ ■	646X3-M-0.30	■ ■
1.0	3	3	0.35	636X3-M-0.35	■ ■	646X3-M-0.35	■ ■
1.0	3	3	0.40	636X3-M-0.40	■ ■	646X3-M-0.40	■ ■
1.0	3	3	0.45	636X3-M-0.45	■ ■	646X3-M-0.45	■ ■
1.0	3	3	0.50	636X3-M-0.50	■ ■	646X3-M-0.50	■ ■
1.5	5	5	0.60	636X3-M-0.60	■ ■	646X3-M-0.60	■ ■
1.5	5	5	0.70	636X3-M-0.70	■ ■	646X3-M-0.70	■ ■
1.5	5	5	0.75	636X3-M-0.75	■ ■	646X3-M-0.75	■ ■
1.5	5	5	0.80	636X3-M-0.80	■ ■	646X3-M-0.80	■ ■
2.0	7	5	1.00	636X3-M-1.00	■ ■	646X3-M-1.00	■ ■
2.0	7	5	1.25	636X3-M-1.25	■ ■	646X3-M-1.25	■ ■
2.0	7	5	1.50	636X3-M-1.50	■ ■	646X3-M-1.50	■ ■

# PRO-LINE

Plaquettes à rayon  
 Radius Wendeplatten  
 Radius inserts

637 / 647

L

R

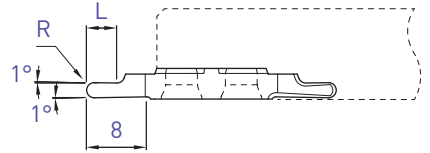
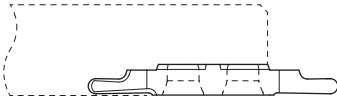
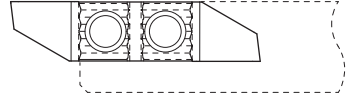
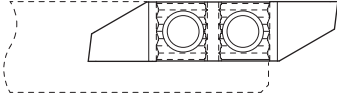

L

R

R	L	Art. N°	TiAlN N (µk20)	HTA HN (µk10)	Art. N°	TiAlN N (µk20)	HTA HN (µk10)
0.25	1.5	-			647-R0.25	■ ■	
0.4	2	-			647-R0.4	■ ■	
0.5	2.5	637-R0.5	■ ■		647-R0.5	■ ■ □ □	
0.6	2.5	-			647-R0.6	■ ■	
0.75	3	-			647-R0.75	■ ■	
0.8	3	-			647-R0.8	■ ■	
1.0	4	637-R1.0	■ ■		647-R1.0	■ ■	
1.5	6	-			647-R1.5	■ ■	

Plaquettes à rayon  
 Radius Wendplatten  
 Radius inserts

647ZX10

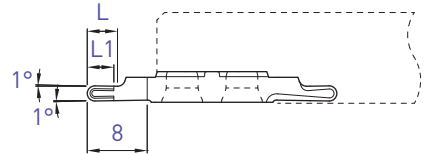
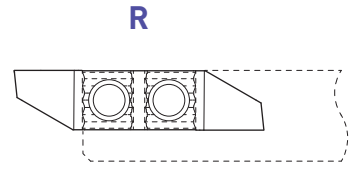
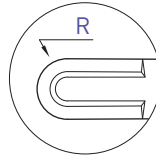
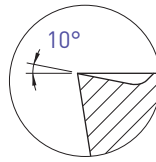

Pour un meilleur contrôle des copeaux  
 Für eine bessere Spankontrolle  
 For a better chip-control

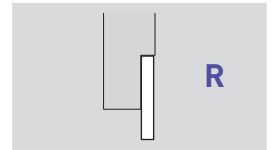

R	L	L1	Art. N°	TiAlN N (µk20)
1.0	4	3.5	647ZX10-R1.0	■
1.5	6	4	647ZX10-R1.5	■

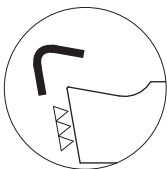

Arête de coupe honée  
 Gehonte Schneidkante  
 Honed edge

f min: 0.02 mm/U

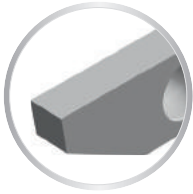
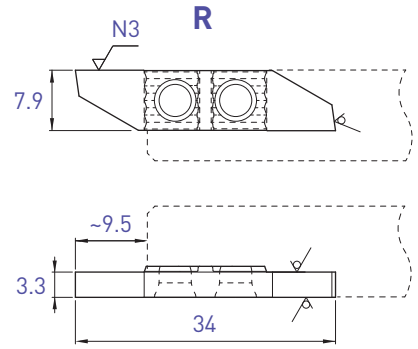
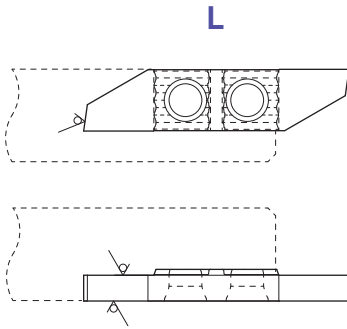

Face de coupe polie  
 Polierte Schneidfläche  
 Polished cutting face

L				R			
Art. N°	TiAlN N (µk20)	HTA	HN (µk10)	Art. N°	TiAlN N (µk20)	HTA	HN (µk10)
631-EP	■ ■	■ ■	■ ■	641-EP	■ ■	■ ■	■ ■

Porte-outils

Halter

Holder

650 / 660

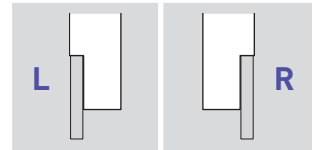
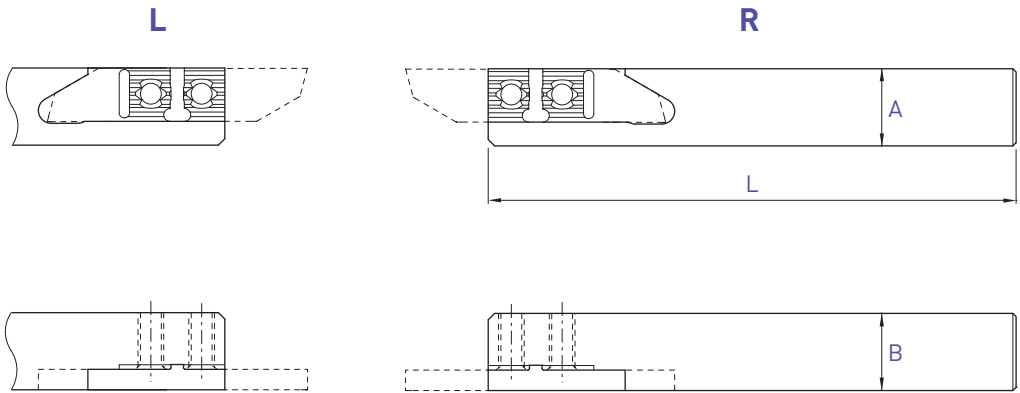

A x B	L	Art. N°	Art. N°
8 x 8	115	650-8	660-8
10 x 10	115	650-10	660-10
10 x 10	50	650-10-50	660-10-50
12 x 12	130	650-12	660-12
12 x 12	90	650-12-90	660-12-90
12.7 x 12.7	130	650-12.7	660-12.7
16 x 16	130	650-16	660-16
16 x 16	75	650-16-75	660-16-75
20 x 20	120	650-20	660-20

Chaque support est livré avec vis et clé.

Jeder Halter wird mit Spannschraube(n) und Schlüssel geliefert.

Screw(s) and key are included with each tool holder.

■ = disponible / verfügbar / available

□ = selon disponibilité du stock / jenach Lagerverfügbarkeit / depending on stock availability

Porte-outils

Halter

Holder

Coupe à droite déportée

Versetztes Rechtsschneiden

Right cut off line

## 650 RC

Utiliser des plaquettes type 651R  
WSP Typ 651R verwenden  
Use inserts type 651R

Voir dès page 3.39  
Siehe ab Seite 3.39  
See from page 3.39

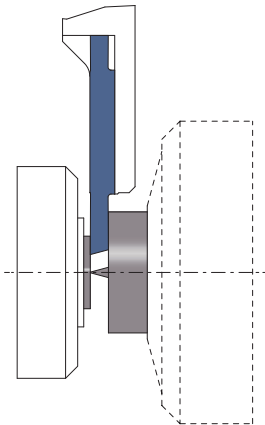
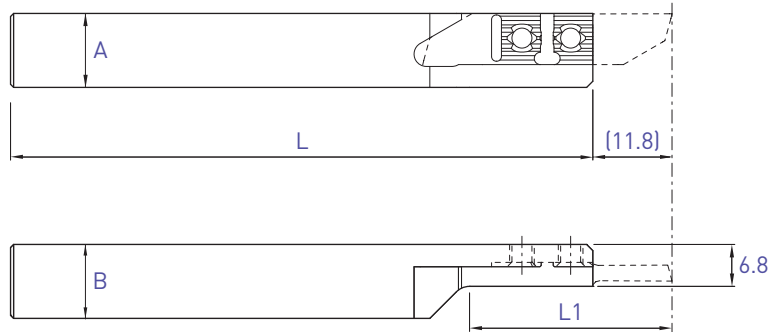

 <b>L (R)</b> Coupe à droite déportée Versetztes Rechtsschneiden Right cut off line			
A x B	L	L1	Art. N°
10 x 10	115	32	<b>650RC-10</b>
12 x 12	130	32	<b>650RC-12</b>
16 x 16	130	42	<b>650RC-16</b>

Chaque support est livré avec vis et clé.  
Jeder Halter wird mit Spannschraube(n) und Schlüssel geliefert.  
Screw(s) and key are included with each tool holder.

Porte-outils avec arrosage intégré  
 Halter mit integrierter Kühlmittelzufuhr  
 Holders with integrated coolant supply

650-JET / 660-JET

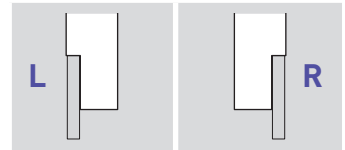
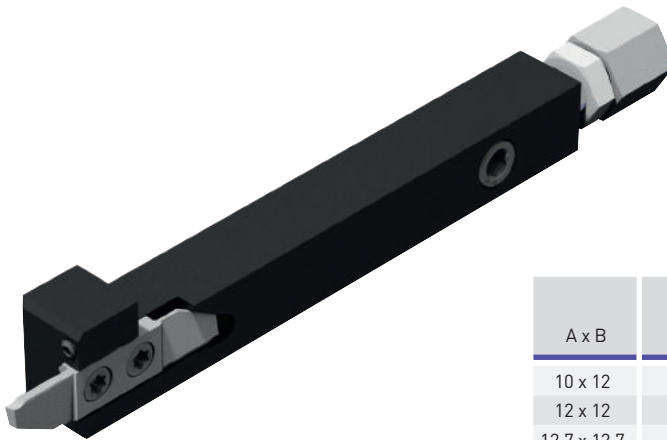
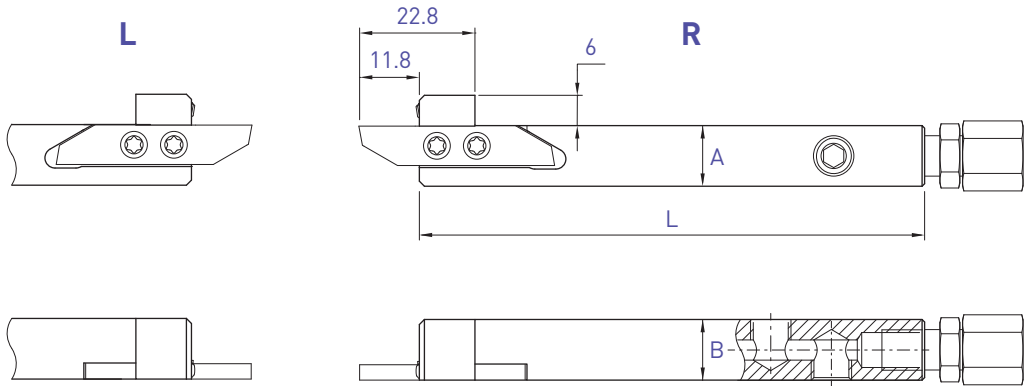

A x B	L	Art. N°	Art. N°
10 x 12	100	650-1012-JET	660-1012-JET
12 x 12	100	650-12-JET	660-12-JET
12.7 x 12.7	100	650-12.7-JET	660-12.7-JET
16 x 16	100	650-16-JET	660-16-JET
20 x 20	100	650-20-JET	660-20-JET

Chaque support est livré avec vis, clé, raccord droit et buse d'arrosage Ø 1.5 mm.  
 Jeder Halter wird mit Spannschraube(n), Schlüssel, gerader Kühlmittelanschluss und Kühlmitteldüse Ø 1.5 mm geliefert.  
 Screws(s), key, straight connector and coolant nozzle Ø 1.5 mm are included with each tool holder.

L

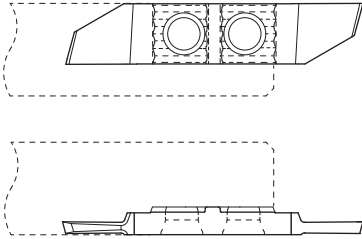

R

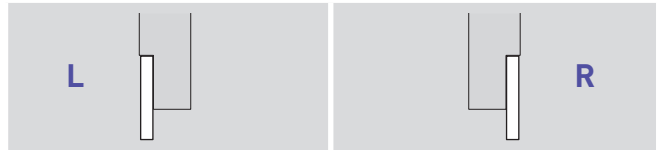
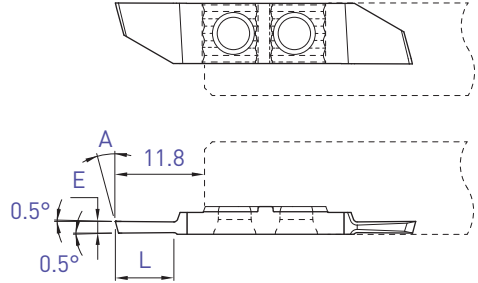

E	A	L	Art. N°	TiAlN		HTA	HN [µk(10)]	Art. N°	TiAlN		HTA	HN [µk(10)]
				N	(µk20)				N	(µk20)		
0.8	20°	5	651-0.8-20°	■	■			661-0.8-20°	■	■	□	□
1.0	15°	5	-					661-1.0-15°	■	■	□	□
1.0	20°	5	651-1.0-20°	■	■			661-1.0-20°	■	■	□	□
1.2	15°	5	-					661-1.2-15°	■	■	□	□
1.2	20°	5	651-1.2-20°	■	■			661-1.2-20°	■	■	□	□
1.5	15°	7.5	651-1.5-15°	■	■			661-1.5-15°	■	■	□	□
1.5	20°	7.5	-					661-1.5-20°	■	■	□	□
1.8	15°	9	651-1.8-15°	■	■			661-1.8-15°	■	■	□	□
2.0	15°	11	651-2.0-15°	■	■			661-2.0-15°	■	■	□	□
2.5	15°	11	651-2.5-15°	■	■			661-2.5-15°	■	■	□	□



Tronçonnage

Abstechen

Parting off

651XF / 661XF

L

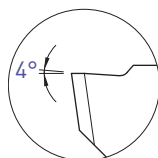
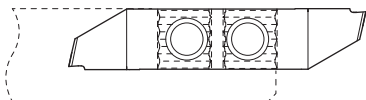

R

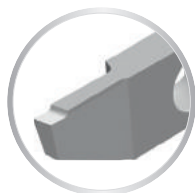
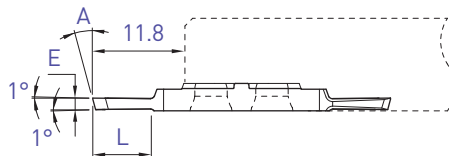
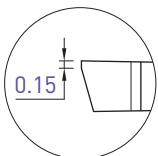
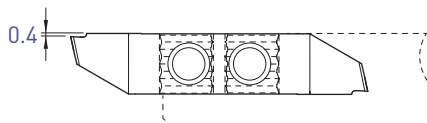

L



R



E	A	L	Art. N°	TiAlN N [µk20]	HTA HN [µk10]	Art. N°	TiAlN N [µk20]	HTA HN [µk10]
1.5	15°	7.5	651XF-1.5	■ ■		661XF-1.5	■ ■	□ □
2.0	15°	11	651XF-2.0	■ ■		661XF-2.0	■ ■	□ □

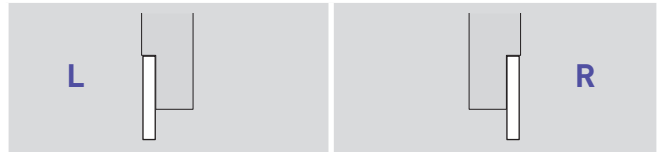
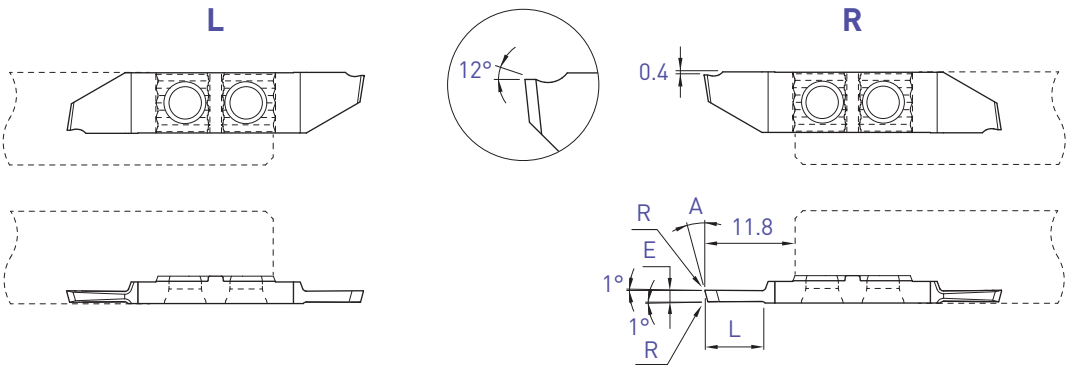

E	A	L	R	Art. N°	TiAlN N [µk20]	HTA HN [µk10]	Art. N°	TiAlN N [µk20]	HTA HN [µk10]
1.0	15°	5	0.03	651X12-1.0	■ ■		661X12-1.0	■ ■	□ □
1.5	15°	7.5	0.03	651X12-1.5	■ ■		661X12-1.5	■ ■	□ □
2.0	15°	11	0.03	651X12-2.0	■ ■		661X12-2.0	■ ■	□ □

Tronçonnage

Abstechen

Parting off

651U / 661U

L

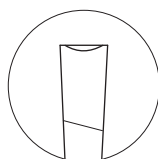
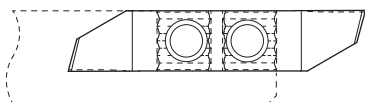

R

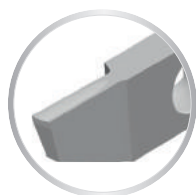
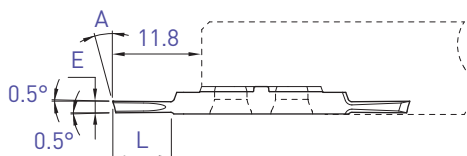
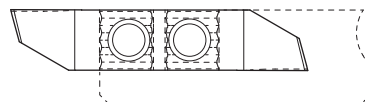

L

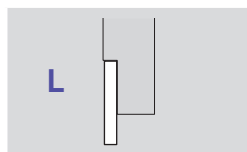

R

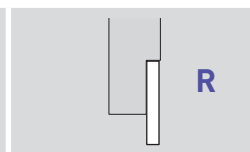

E	A	L	Art. N°	TiAlN N (µm20)	Art. N°	TiAlN N (µm20)
1.5	15°	7.5	651U-1.5	■ ■	661U-1.5	■ ■
2.0	15°	11	651U-2.0	■ ■	661U-2.0	■ ■

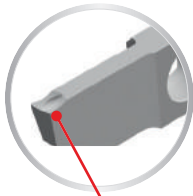
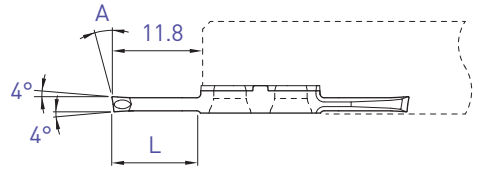
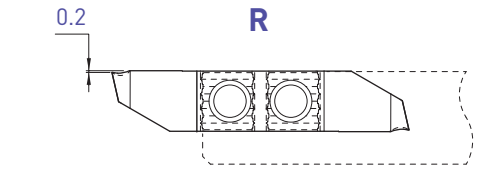
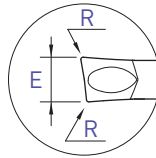
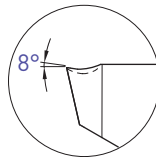

Pour un meilleur contrôle des copeaux  
Für eine bessere Spankontrolle  
For a better chip-control

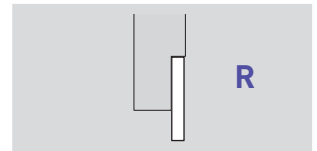
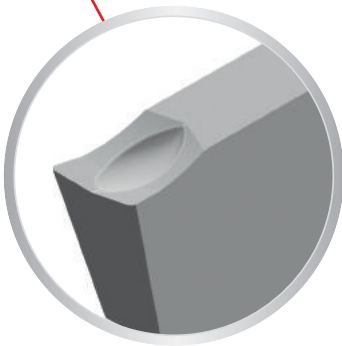

E	A	L	R	Art. N°	TiAlN N (µk20)
2.0	8°	11	0.10	661ZU8-2.0-8°-R10	■



Arête de coupe honée  
Gehonte Schneidkante  
Honed edge

f min: 0.02 mm/U

Tronçonnage  
Abstechen  
Parting off

Coupe déportée  
Versetztes Schneiden  
Cut off line

651R

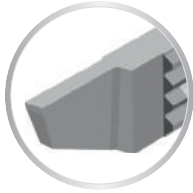

Cut R

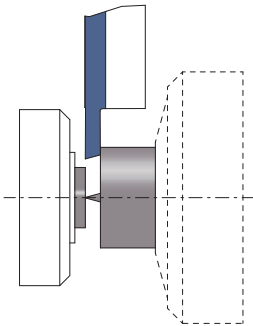
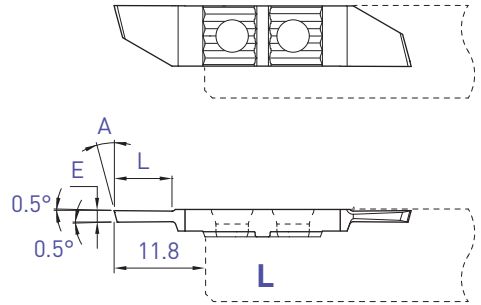

L (R)

Coupe à droite déportée  
Versetztes Rechtsschneiden  
Right cut off line

E	A	L	Art. N°	Ti/AlN N (µk20)	HTA	HN (µk10)
1.0	15°	5	651R-1.0-15°	■ ■	□ □	
1.2	15°	5	651R-1.2-15°	■ ■	□ □	
1.5	15°	7.5	651R-1.5-15°	■ ■	□ □	
2.0	15°	11	651R-2.0-15°	■ ■	□ □	
2.5	15°	11	651R-2.5-15°	■ ■	□ □	

Tronçonnage  
 Abstechen  
 Parting off

Coupe déportée  
 Versetztes Schneiden  
 Cut off line

651RXF

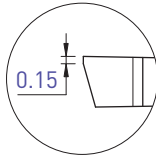
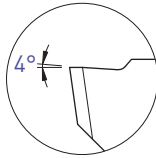
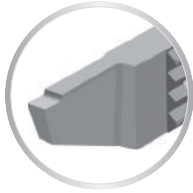

Cut R

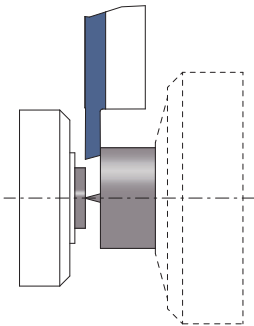
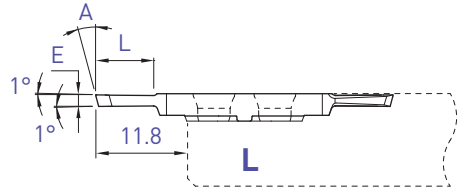
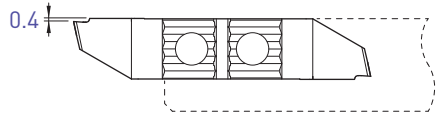

L (R)

Coupe à droite déportée  
 Versetztes Rechtsschneiden  
 Right cut off line

E	A	L	Art. N°	Ti/AlN N (µk20)	HTA	HN (µk10)
1.5	15°	7.5	651RXF-1.5	■ ■	□ □	
2.0	15°	11	651RXF-2.0	■ ■	□ □	

Tronçonnage  
Abstechen  
Parting off

Coupe déportée  
Versetztes Schneiden  
Cut off line

651RX12

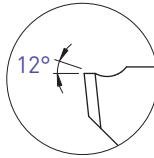
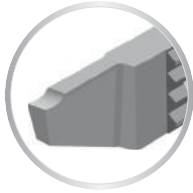

Cut R

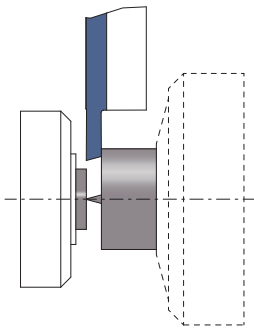
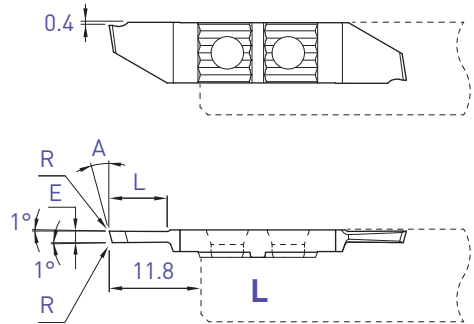

L (R)

Coupe à droite déportée  
Versetztes Rechtsschneiden  
Right cut off line

E	A	L	R	Art. N°	Ti/AIN N (µk20)	HTA	HN (µk10)
1.5	15°	7.5	0.03	651RX12-1.5	■ ■	□ □	
2.0	15°	11	0.03	651RX12-2.0	■ ■	□ □	

Tronçonnage  
 Abstechen  
 Parting off

Coupe déportée  
 Versetztes Schneiden  
 Cut off line

**651RU**

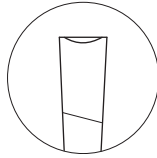

**Cut R**

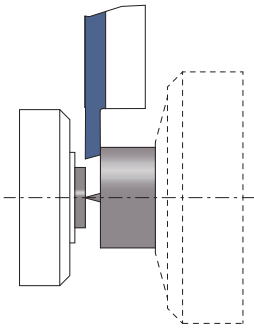
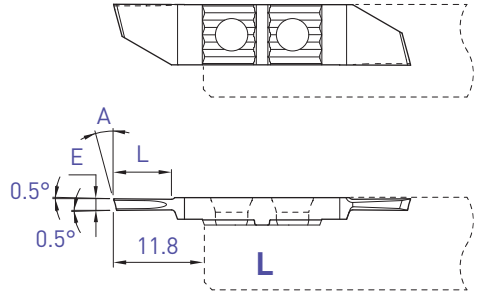

**L (R)**

Coupe à droite déportée  
 Versetztes Rechtsschneiden  
 Right cut off line

E	A	L	Art. N°	TiAlN N (µk20)
1.5	15°	7.5	<b>651RU-1.5</b>	■ ■
2.0	15°	11	<b>651RU-2.0</b>	■ ■



Tronçonnage  
Abstechen  
Parting off

Coupe déportée  
Versetztes Schneiden  
Cut off line

651RZU

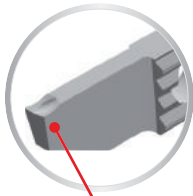
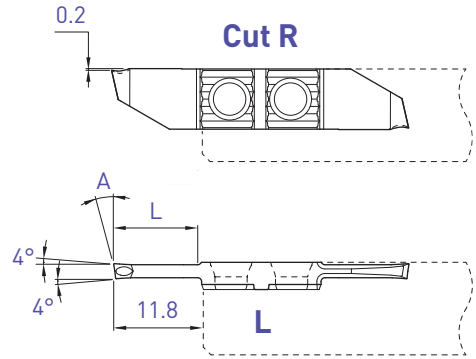
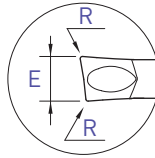
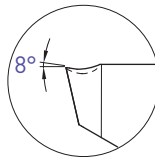

Pour un meilleur contrôle des copeaux  
Für eine bessere Spankontrolle  
For a better chip control

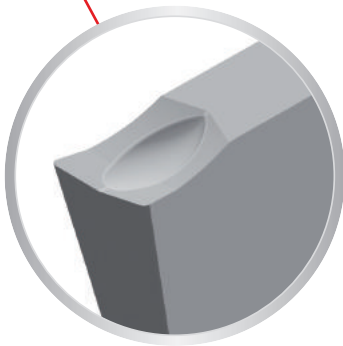

L (R)

Coupe à droite déportée  
Versetztes Rechtsschneiden  
Right cut off line

E	A	L	R	Art. N°	TiAlN N (µm20)
2.0	8°	11	0.10	651RZU8-2.0-8°-R10	■

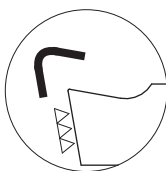

Arête de coupe honée  
Gehonte Schneidkante  
Honed edge

f min: 0.02 mm/U

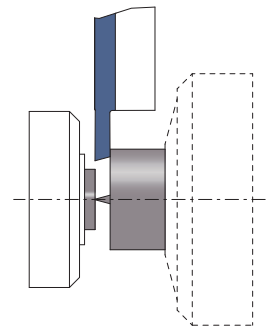

**L**

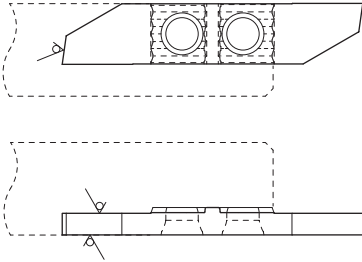

**R**

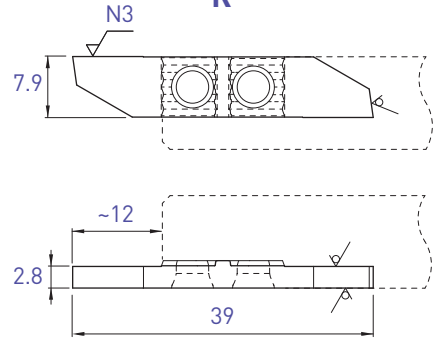





Face de coupe polie  
 Polierte Schneidfläche  
 Polished cutting face

L				R			
Art. N°	TiAlN N (µk20)	HTA	HN (µk10)	Art. N°	TiAlN N (µk20)	HTA	HN (µk10)
651-EP	■ ■	■ ■		661-EP	■ ■	■ ■	

Pièces de rechange et accessoires

Ersatzteile und Zubehöre

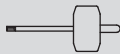
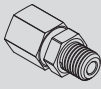
Spare parts and accessories

Pièces de rechange Ersatzteile Spare parts							
Porte-outils Halter Holders						Option Art. N°	Recommandation de serrage Drehmoment Empfehlung Clamping recommendation
630 640			-	-	-		
630-JET 640-JET	V-M4X9-T15		J-M8X1-D6	JB-M8X1	JJ-M3X6-D1.5		
650 660		C-T15	-	-	-	SET-NM-TX15	3 Nm
650-RC	V-M4X6.5-T15		-	-	-		
650-JET 660-JET	V-M4X9-T15		J-M8X1-D6	JB-M8X1	JJ-M3X6-D1.5		

■ = disponible / verfügbar / available

□ = selon disponibilité du stock / jenach Lagerverfügbarkeit / depending on stock availability



261

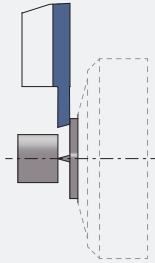

251R

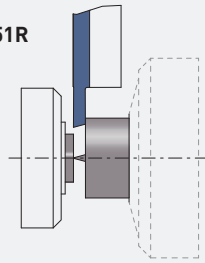

262

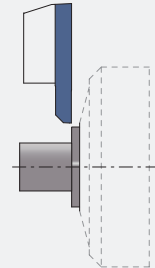

263

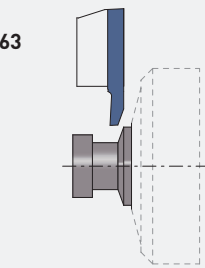

264

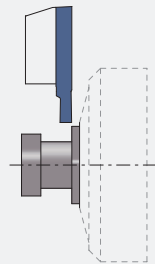

266

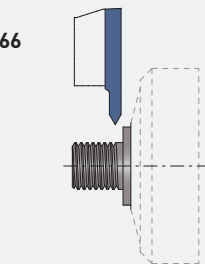

Nuances  
Sorten  
Grades > 4.02

Paramètres de coupe indicatifs  
Empfohlene Schnittwerte  
Standard machining data > 4.03

Accessoires  
Zubehör  
Accessories

Porte-outils  
Halter  
Holders > 4.04

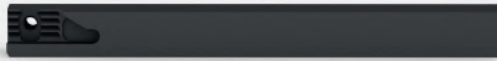

Tronçonnage  
Abstechen  
Parting off > 4.08

**Type 251 / 261**



Tournage avant  
Vorwärts drehen  
Front turning > 4.10

**Type 252 / 262**



Tournage arrière  
Rückwärts drehen  
Back turning > 4.11

**Type 253 / 263**



Fonçage-tournage  
Einstechen und drehen  
Grooving and turning > 4.14

**Type 254 / 264**



Filetage  
Gewinde drehen  
Threading > 4.16

**Type 256 / 266**



Plaquettes ébauches  
WSP-Rohlinge  
Blank inserts > 4.17

**Type 251E / 261E**



Usinage axial  
Axiale Bearbeitung  
Axial machining > 4.18 **new**

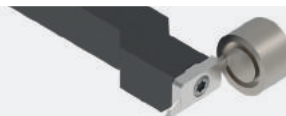

### AP302

μK20 + revêtement PVD  
μK20 + PVD Beschichtung  
μK20 + PVD coating

- excellente nuance universelle
- 1<sup>er</sup> choix pour l'usinage des aciers, aciers inoxydables et alliages de titane
- très bonne résistance à la température

- beste Universalsorte
- für die Bearbeitung von Stahl, rostfreiem Stahl und Titanlegierungen bestens geeignet
- sehr gute Warmfestigkeit

- best universal grade
- first choice for steel, stainless steel and titanium alloys machining
- very good heat resistance

### AP202

μK20 + revêtement PVD  
μK20 + PVD Beschichtung  
μK20 + PVD coating

- nuance particulièrement adaptée aux faibles vitesses de coupe

- besonders geeignete Sorte für niedrige Schnittgeschwindigkeiten

- grade particularly suitable for low cutting speeds

### N (μK20)

non revêtu  
unbeschichtet  
uncoated

- nuance micro-grain tenace
- supporte les coupes interrompues et autres conditions d'usinage défavorables

- zähe Feinkornsorte
- für unterbrochene Schnitte und andere ungünstige Bearbeitungsbedingungen geeignet

- tough micro-grain grade
- suitable for interrupted cut and other unfavourable machining conditions

### AH302

μK10 + revêtement PVD  
μK10 + PVD Beschichtung  
μK10 + PVD coating

- nuance très résistante à l'usure
- pour l'usinage en finition dans des conditions favorables des aciers, aciers inoxydables et alliages de titane

- sehr verschleißfeste Sorte
- für die Feinbearbeitung von Stahl, rostfreiem Stahl und Titanlegierungen bei guten Bearbeitungsbedingungen

- very wear resistant grade
- for light machining of steel, stainless steel and titanium alloys under favourable machining conditions

### HN (μK10)

non revêtu  
unbeschichtet  
uncoated

- nuance micro-grain très résistante à l'usure
- recommandé pour l'usinage du titane faiblement allié
- déconseillé en cas de coupe interrompue et autres conditions d'usinage défavorables

- verschleißfeste Feinkornsorte
- für die Bearbeitung von niedrig legiertem Titan empfehlenswert
- für unterbrochene Schnitte und andere ungünstige Bearbeitungsbedingungen nicht geeignet

- wear resistant micro-grain grade
- suitable for the machining of low alloyed titanium
- not suitable for interrupted cut and other unfavourable machining conditions

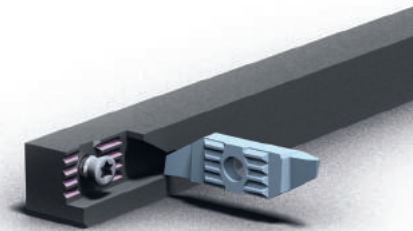

*Rigid clamping system*

Paramètres de coupe indicatifs

Empfohlene Schnittwerte



Standard machining data

Matière Werkstoff Material	Tournage Drehen Turning		Tronçonnage Abstechen Parting off		
	VC (m/min)	F (mm/U)	VC (m/min)	F (mm/U)	
Acier de décolletage Automatenstahl Free-cutting steel	<b>P</b>	120 - 200	0.01 - 0.20	80 - 150	0.01 - 0.15
Acier Stahl Steel < 600 N/mm <sup>2</sup>	<b>P</b>	80 - 160	0.01 - 0.18	70 - 120	0.01 - 0.12
Acier Stahl Steel < 800 N/mm <sup>2</sup>	<b>P</b>	60 - 120	0.01 - 0.15	60 - 100	0.01 - 0.10
Acier Stahl Steel > 800 N/mm <sup>2</sup>	<b>P</b>	50 - 100	0.01 - 0.12	40 - 80	0.01 - 0.08
Acier inoxydable Rostfreistahl Stainless steel	<b>M</b>	60 - 120	0.01 - 0.15	60 - 100	0.01 - 0.08
Aluminium	<b>N</b>	180 - 800	0.01 - 0.30	150 - 300	0.01 - 0.20
Cuivre, laiton, bronze Kupfer, Messing, Bronze Copper, brass, bronze	<b>N</b>	100 - 500	0.01 - 0.30	100 - 300	0.01 - 0.20
Titane Titan Titanium	<b>S</b>	30 - 70	0.01 - 0.12	30 - 50	0.01 - 0.06

Accessoires

Zubehöre

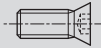
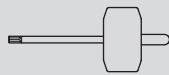
Accessories

Porte-outils Halter Holders			
250-8 / 260-8	<b>V-M3.5X7.3-T15</b>	<b>C-T15</b>	<b>SET-NM-TX15</b>
250-... / 260-...	<b>V-M4X9-T15</b>		
250RC / 260-C	<b>V-M4X7.3-T15</b>		

Recommandation de serrage  
Drehmoment Empfehlung  
Clamping recommendation

3.0 Nm

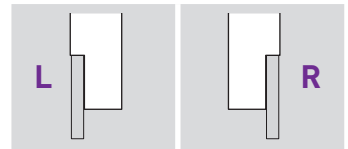
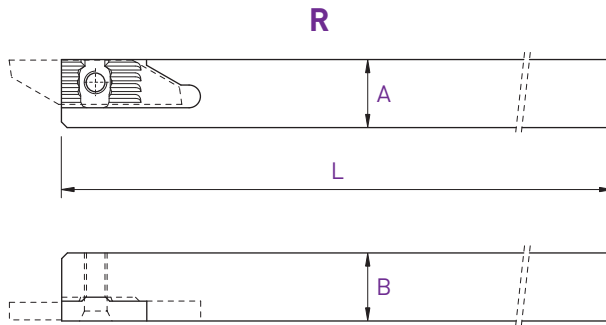

A x B	L	Art. N°	Art. N°
8 x 8	115	250-8	260-8
10 x 10	115	250-10	260-10
12 x 12	130	250-12	260-12
12 x 12	90	250-12-90	260-12-90
12.7 x 12.7	130	250-12.7	260-12.7
16 x 16	130	250-16	260-16
16 x 16	75	250-16-75	260-16-75
20 x 20	120	250-20	260-20

Chaque support est livré avec vis et clé.  
 Jeder Halter wird mit Spannschraube(n) und Schlüssel geliefert.  
 Screw(s) and key are included with each tool holder.



Porte-outils

Halter

Holder

260-C

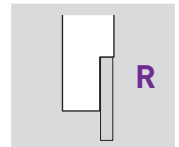
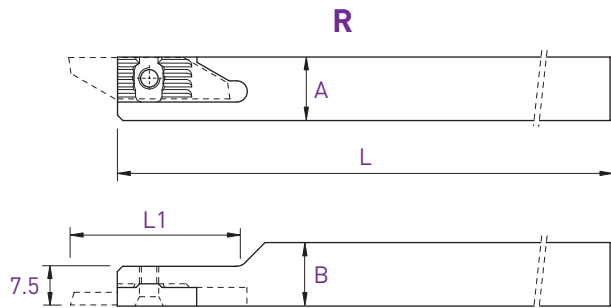
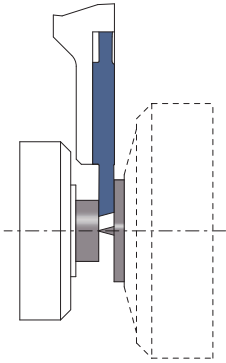

A x B	L	L1	Art. N°
12 x 12	130	30	260-C-12

Porte-outils

Halter

Holder

Coupe à droite déportée  
Versetzes Rechtsschneiden  
Right cut off line

250RC

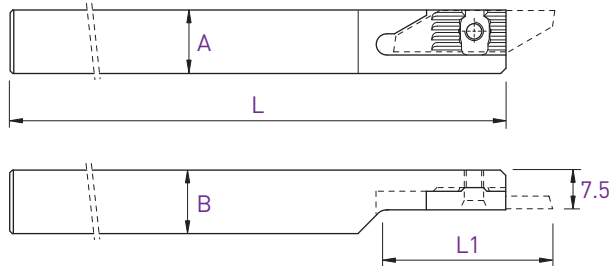
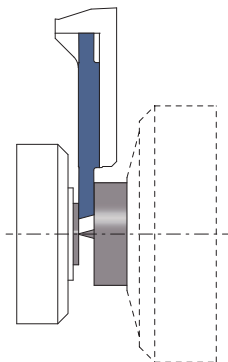

L (R)			
Coupe à droite déportée Versetzes Rechtsschneiden Right cut off line			
A x B	L	L1	Art. N°
12 x 12	130	30	250RC-12
16 x 16	130	40	250RC-16

Utiliser des plaquettes type 251R  
WSP Typ 251R verwenden  
Use inserts type 251R



Chaque support est livré avec vis et clé.  
Jeder Halter wird mit Spannschraube(n) und Schlüssel geliefert.  
Screw(s) and key are included with each tool holder.

Porte-outils avec arrosage intégré  
 Halter mit integrierter Kühlmittelzufuhr  
 Holders with integrated coolant supply

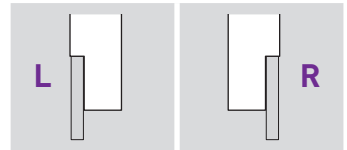
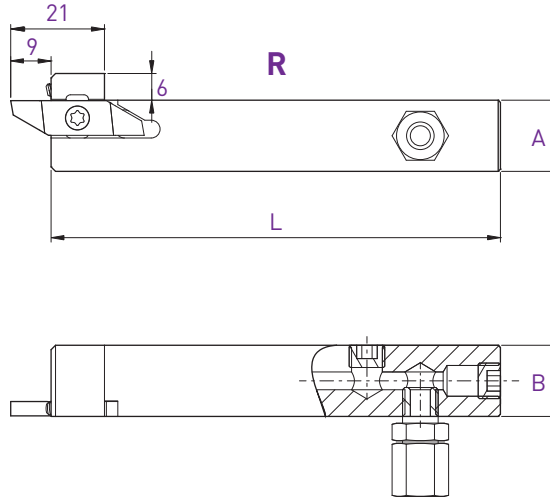
## 250-JET / 260-JET

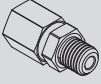

A x B	L	Art. N°	Art. N°
10 x 12	100	250-1012-JET	260-1012-JET
12 x 12	100	250-12-JET	260-12-JET
16 x 16	100	250-16-JET	260-16-JET
20 x 20	100	250-20-JET	260-20-JET

Pièces de rechange Ersatzteile Spare parts			Buse Düse Nozzle 
	Art. N°	Art. N°	Art. N°
250-JET / 260-JET	J-M8X1-D6	JB-M8X1	JJ-M3X6-D1.5

Chaque support est livré avec vis et clé.  
 Jeder Halter wird mit Spannschraube(n) und Schlüssel geliefert.  
 Screw(s) and key are included with each tool holder.

Porte-outils

Halter

Holder

260/250F

L/R

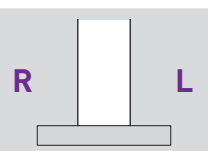
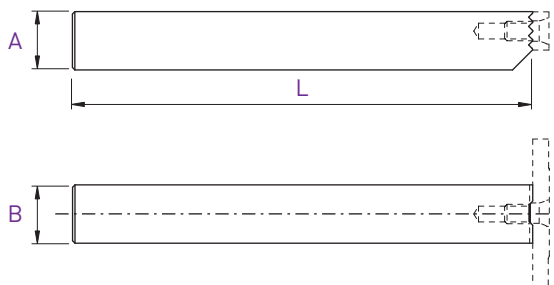

A x B	L	Art. N°
10 x 12	120	260/250F-1012
12 x 12	120	260/250F-1212

Porte-outils

Halter

Holder

260/250-D

L/R

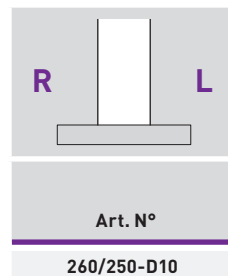
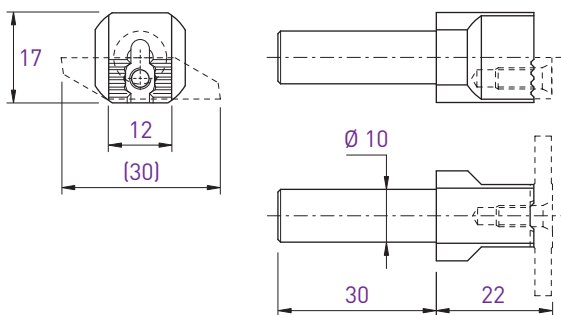

Chaque support est livré avec vis et clé.  
 Jeder Halter wird mit Spannschraube(n) und Schlüssel geliefert.  
 Screw(s) and key are included with each tool holder.

# ECO-LINE

Tronçonnage  
Abstechen  
Parting off

251 / 261

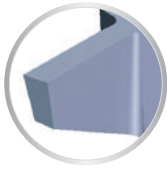
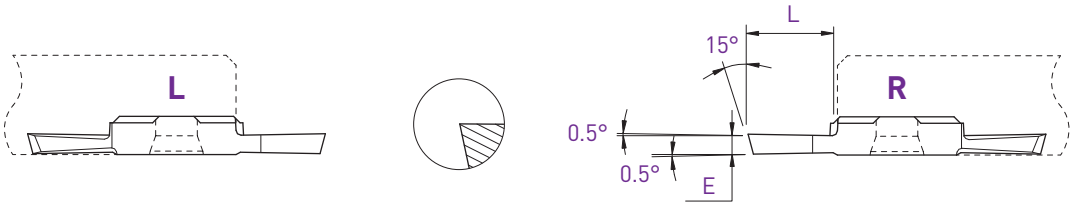

E	L	Art. N°	AP302	AP202	N (µk20)	Art. N°	AP302	AP202	N (µk20)
0.8	4	251-0.8	■	□	■	261-0.8	■	□	■
1.0	5	251-1.0	■	□	■	261-1.0	■	□	■
1.2	5	251-1.2	■	□	■	261-1.2	■	□	■
1.5	7	251-1.5	■	□	■	261-1.5	■	□	■
2.0	8.5	251-2.0	■	□	■	261-2.0	■	□	■
2.5	8.5	251-2.5	■	□	■	261-2.5	■	□	■

Tronçonnage  
Abstechen  
Parting off

Coupe déportée  
Versetztes Schneiden  
Cut off line

261L / 251R

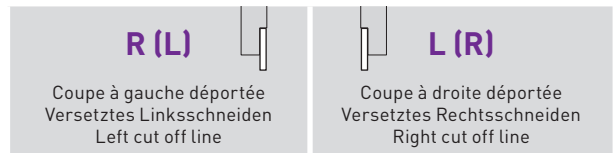
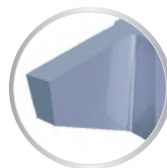
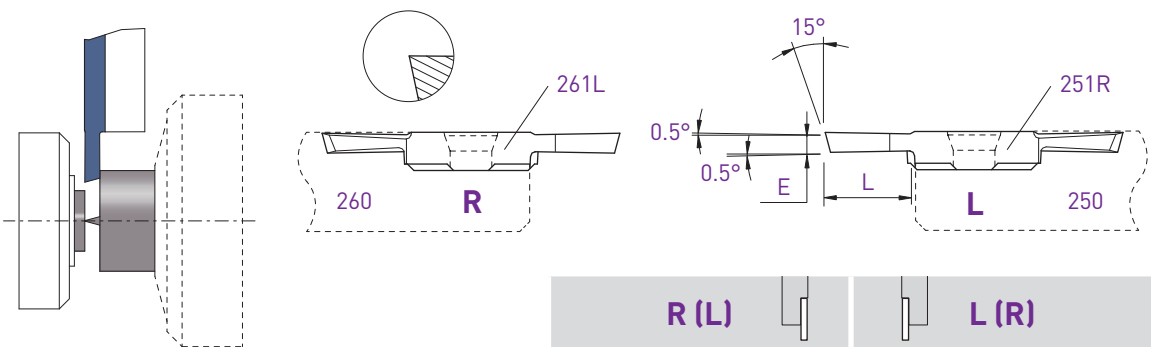

R (L)			L (R)						
Coupe à gauche déportée Versetztes Linksschneiden Left cut off line			Coupe à droite déportée Versetztes Rechtsschneiden Right cut off line						
E	L	Art. N°	AP302	AP202	N (µk20)	Art. N°	AP302	AP202	N (µk20)
1.0	5	-				251R-1.0	■	□	■
1.5	7	-				251R-1.5	■	□	■
2.0	8.5	261L-2.0	■	□	■	251R-2.0	■	□	■

Tronçonnage

Abstechen

Parting off

251XF / 261XF

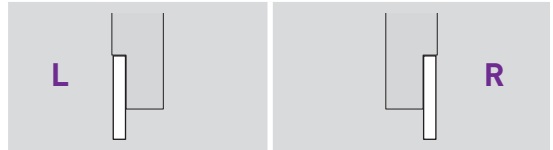
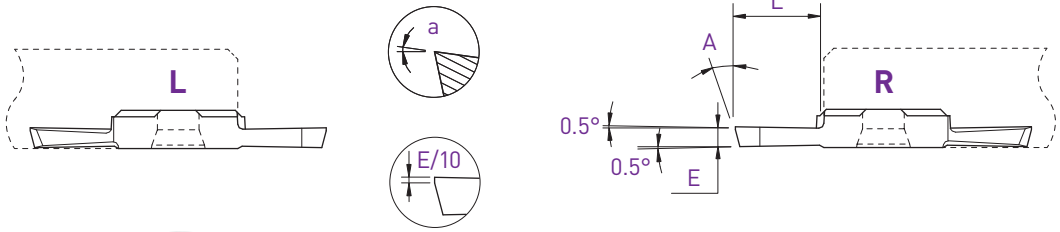

a	E	L	A	Art. N°	AP302	AP202	N (µk20)	Art. N°	AP302	AP202	N (µk20)
4°	1.0	4	15°	-				261XF-1.0	■	■	
6°	1.0	4	8°	-				261XF6°-1.0-8°	■	■	
4°	1.5	7	15°	251XF-1.5	■	□	■	261XF-1.5	■	□	■
4°	2.0	8.5	15°	251XF-2.0	■	□	■	261XF-2.0	■	□	■

Tronçonnage

Abstechen

Parting off

Coupe déportée

Versetztes Schneiden

Cut off line

251RXF

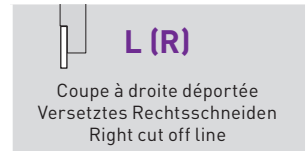
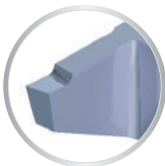
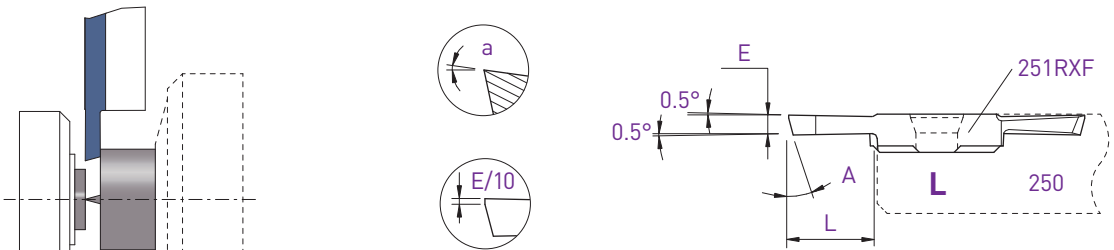

a	E	L	A	Art. N°	AP302	AP202	N (µk20)
6°	1.0	4	8°	251RXF6°-1.0-8°	■	■	
4°	1.5	7	15°	251RXF-1.5	■	□	■
4°	2.0	8.5	15°	251RXF-2.0	■	□	■

■ = disponible / verfügbar / available  
 □ = selon disponibilité du stock / jenach Lagerverfügbarkeit / depending on stock availability

# ECO-LINE

Tournage avant  
Vorwärts drehen  
Front turning

252 / 262

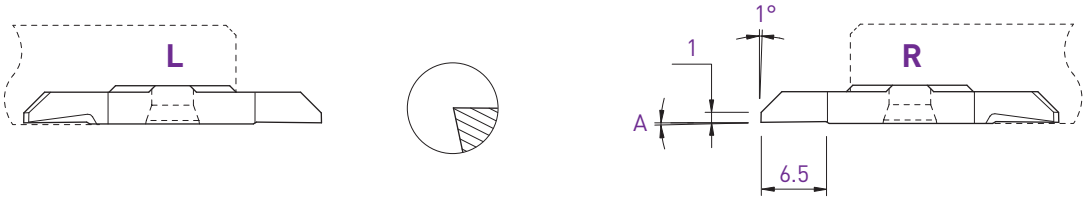

A	Art. N°	AP302	AP202	N (µk20)	Art. N°	AP302	AP202	N (µk20)
0°	252	■	□	■	262	■	□	■
2°	252-2°	■	□	■	262-2°	■	□	■

Tournage avant  
Vorwärts drehen  
Front turning

252X / 262X

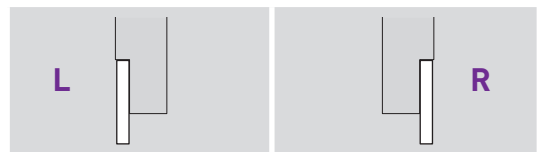
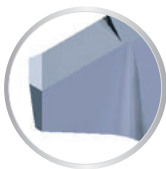
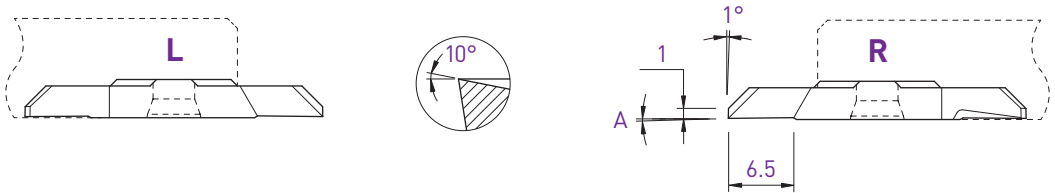

A	Art. N°	AP302	AP202	N (µk20)	Art. N°	AP302	AP202	N (µk20)
0°	252X	■	□	■	262X	■	□	■
2°	252X-2°	■	□	■	262X-2°	■	□	■

Tournage avant  
Vorwärts drehen  
Front turning

252S / 262S

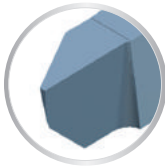
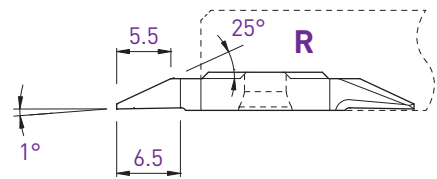
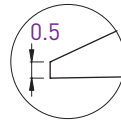
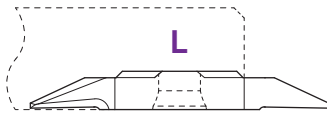

L				R			
Art. N°	AP302	AP202	N (µk20)	Art. N°	AP302	AP202	N (µk20)
252S05	■	□	■	262S05	■	□	■

Tournage arrière  
Rückwärts drehen  
Back turning

253S / 263S

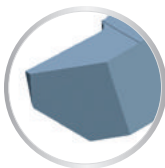
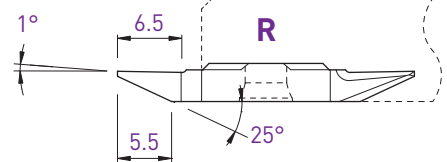
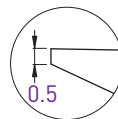
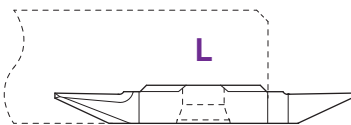

L				R			
Art. N°	AP302	AP202	N (µk20)	Art. N°	AP302	AP202	N (µk20)
253S05	■	□	■	263S05	■	□	■

# ECO-LINE

Tournage arrière  
Rückwärts drehen  
Back turning

253 / 263

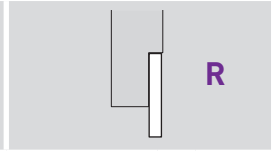
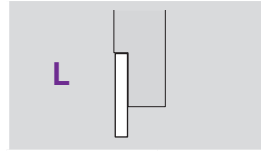
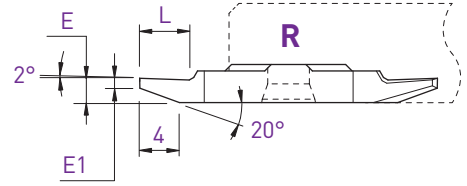
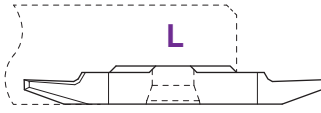

E	E1	L	Art. N°	AP302	AP202	N (µk20)	Art. N°	AP302	AP202	N (µk20)
2.0	0.5	4	253-0.5	■	□	■	263-0.5	■	□	■
2.5	1.0	5	253-1.0	■	□	■	263-1.0	■	□	■

Tournage arrière  
Rückwärts drehen  
Back turning

253X / 263X

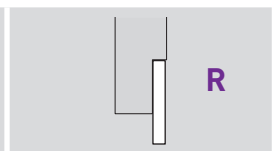
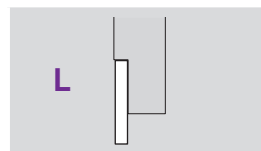
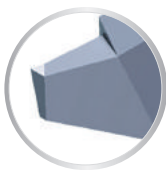
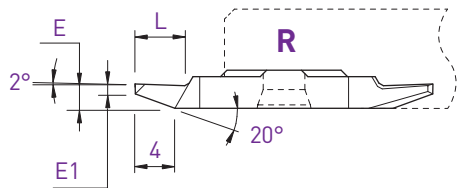
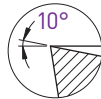
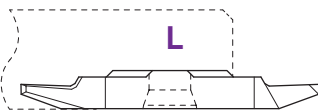

E	E1	L	Art. N°	AP302	AP202	N (µk20)	Art. N°	AP302	AP202	N (µk20)
2.0	0.5	5	253X-0.5	■	□	■	263X-0.5	■	□	■
2.5	1.0	5	253X-1.0	■	□	■	263X-1.0	■	□	■



Tournage arrière  
Rückwärts drehen  
Back turning

253VX-8° / 263VX-8°

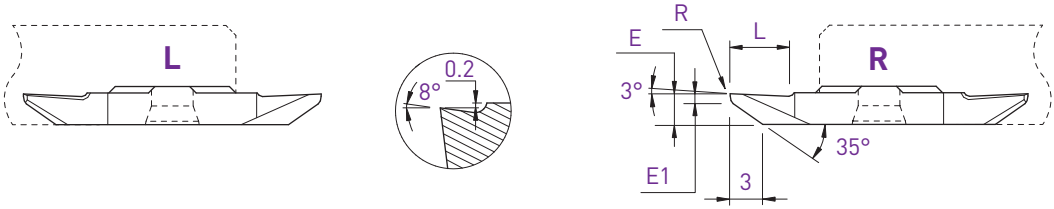

E	E1	L	R	Art. N°	AP302	AP202	N (µk20)	Art. N°	AP302	AP202	N (µk20)	AH302	HN (µk10)
3.1	1.0	6	0	253VX-8°	■	□	■	263VX-8°	■	□	■		
3.1	1.0	6	0.08	-				263VX-8°-R08	■	□	■	■	■
3.1	1.0	6	0.20	-				263VX-8°-R20	■	□	■	■	■

Tournage arrière  
Rückwärts drehen  
Back turning

253VX-805 / 263VX-805

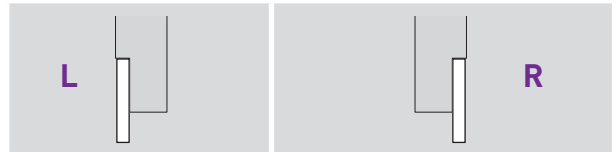
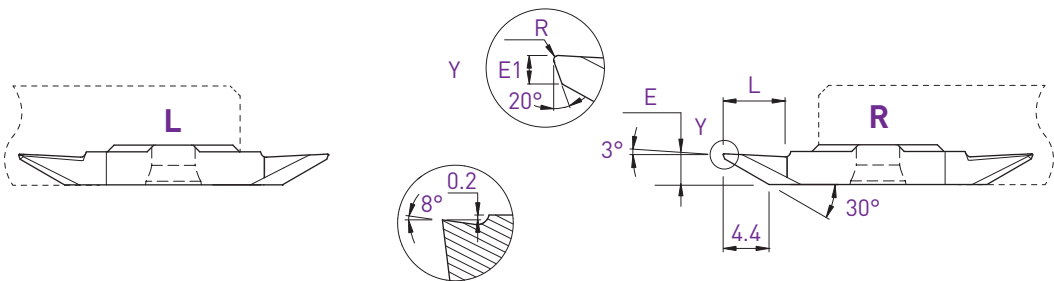

E	E1	L	R	Art. N°	AP302	AP202	N (µk20)	Art. N°	AP302	AP202	N (µk20)	AH302	HN (µk10)
3.0	0.5	6	0.08	253VX-805-R08	■	□	■	263VX-805-R08	■	□	■	■	■

■ = disponible / verfügbar / available  
□ = selon disponibilité du stock / jenach Lagerverfügbarkeit / depending on stock availability

# ECO-LINE

Fonçage-tournage  
 Einstechen und drehen  
 Grooving and turning

254 / 264

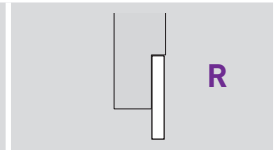
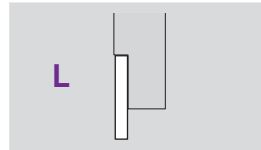
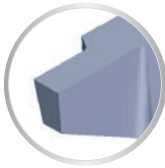
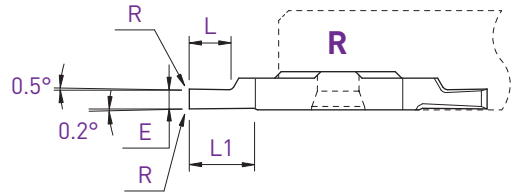
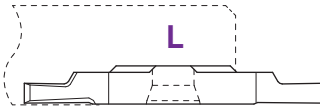

E	L	L1	R	Art. N°	AP302	AP202	N [µk20]	Art. N°	AP302	AP202	N [µk20]
0.8	2	4	0	254-0.8	■	□	■	264-0.8	■	□	■
1.0	2.5	4	0	254-1.0	■	□	■	264-1.0	■	□	■
1.2	3	4	0	254-1.2	■	□	■	264-1.2	■	□	■
1.5	3	4	0	254-1.5	■	□	■	264-1.5	■	□	■
1.8	4	6.5	0	-				264-1.8	■	□	■
2.0	4	6.5	0	254-2.0	■	□	■	264-2.0	■	□	■
2.5	6	6.5	0	254-2.5	■	□	■	264-2.5	■	□	■
3.0	6.5	6.5	0	254-3.0	■	□	■	264-3.0	■	□	■

Fonçage-tournage

Einstecken und drehen

Grooving and turning

254X / 264X

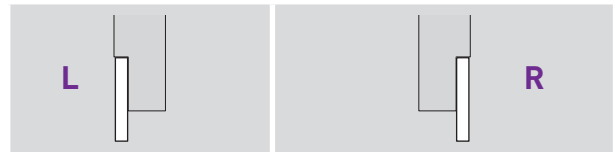
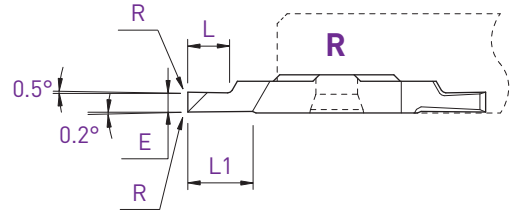
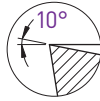
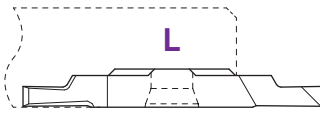

E	L	L1	R	Art. N°	AP302	AP202	N [µk20]	Art. N°	AP302	AP202	N [µk20]	AH302	HN [µk10]
0.8	2	4	0	254X-0.8	■	□	■	264X-0.8	■	□	■		
1.0	2.5	4	0	254X-1.0	■	□	■	264X-1.0	■	□	■		
1.0	2.5	4	0.08	-				264X-1.0-R08	■	□	■	■	■
1.2	3	4	0	254X-1.2	■	□	■	264X-1.2	■	□	■		
1.5	3	4	0	254X-1.5	■	□	■	264X-1.5	■	□	■		
1.5	3	4	0.08	-				264X-1.5-R08	■	□	■	■	■
1.5	3	4	0.20	-				264X-1.5-R20	■	□	■	■	■
2.0	4	6.5	0	254X-2.0	■	□	■	264X-2.0	■	□	■		
2.0	4	6.5	0.08	-				264X-2.0-R08	■	□	■	■	■
2.0	4	6.5	0.20	-				264X-2.0-R20	■	□	■	■	■
2.5	6	6.5	0	254X-2.5	■	□	■	264X-2.5	■	□	■		
2.5	6.5	6.5	0.08	-				264X-2.5-R08	■	□	■	■	■
2.5	6.5	6.5	0.20	-				264X-2.5-R20	■	□	■	■	■
3.0	6.5	6.5	0	254X-3.0	■	□	■	264X-3.0	■	□	■		
3.0	6.5	6.5	0.08	-				264X-3.0-R08	■	□	■	■	■
3.0	6.5	6.5	0.20	-				264X-3.0-R20	■	□	■	■	■

Filetage  
Gewinde drehen  
Threading

Partial profile 60°

256-60 / 266-60

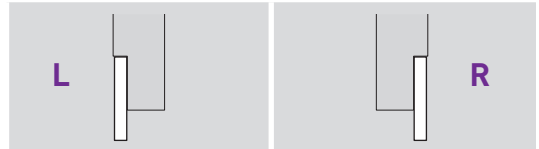
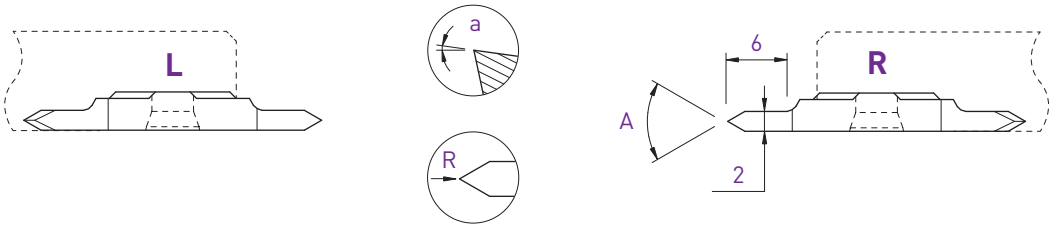

A	R	a	Art. N°	AP302	AP202	N (μk20)	Art. N°	AP302	AP202	N (μk20)
60°	0	0°	256-60-2.0	■	□	■	266-60-2.0	■	□	■
60°	0.06	3°	256-AG60°	■	□	■	266-AG60°	■	□	■

Filetage  
Gewinde drehen  
Threading

Partial profile 55°

256-55 / 266-55

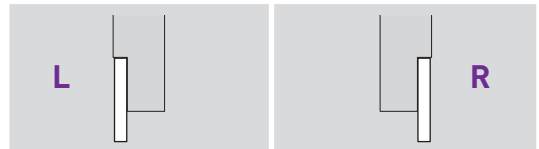
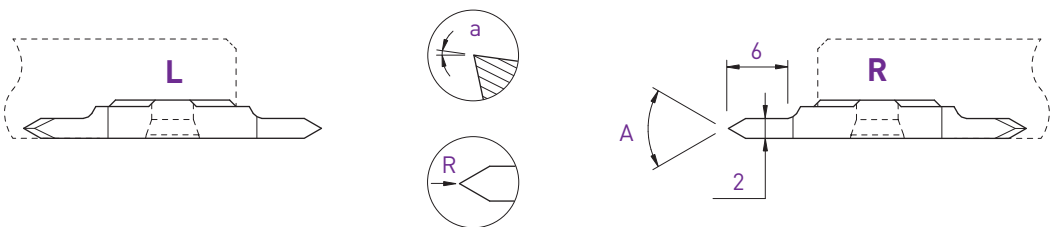

A	R	a	Art. N°	AP302	AP202	N (μk20)	Art. N°	AP302	AP202	N (μk20)
55°	0	0°	256-55-2.0	■	□	■	266-55-2.0	■	□	■
55°	0.06	3°	256-AG55°	■	□	■	266-AG55°	■	□	■

Plaquettes ébauches

WSP-Rohlinge

Blank inserts

251-E / 261-E

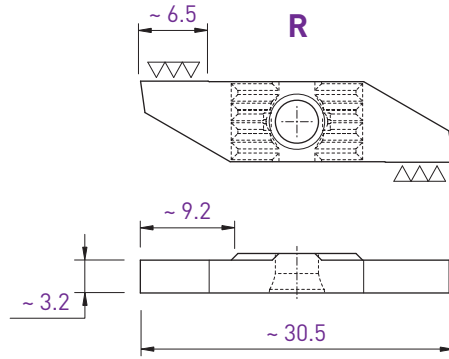
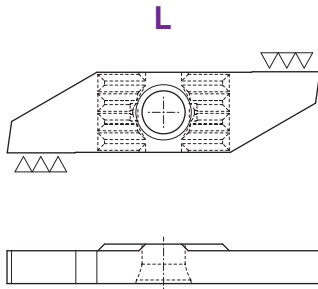

L					R						
Art. N°	AP302	AP202	N [µkt20]	AH302	HN [µkt10]	Art. N°	AP302	AP202	N [µkt20]	AH302	HN [µkt10]
251-E	■	□	■	■	■	261-E	■	□	■	■	■

new

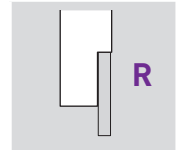
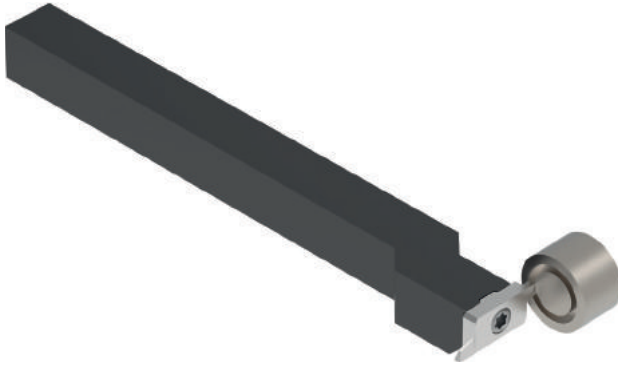
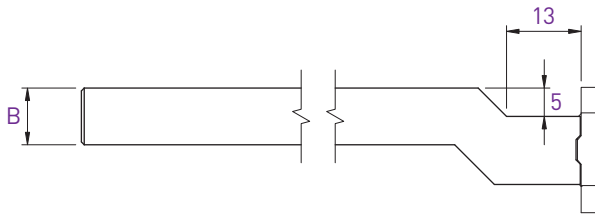
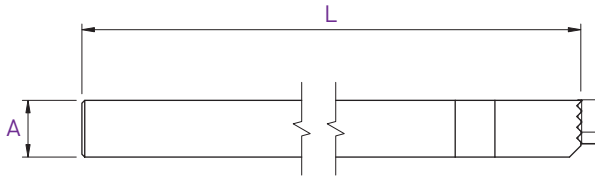

A x B	L	Art. N°
8x10	130	250RFG-0810
10x10	130	250RFG-1010
12x12	130	250RFG-1212
16x16	130	250RFG-1616

Pièces de rechange  
Ersatzteile  
Spare parts

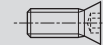

Art. N°

V-M4X9-T15

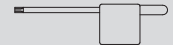

Art. N°

C-T15

Plaquettes ébauches

WSP-Rohlinge

Blank inserts

251RFG

**new**

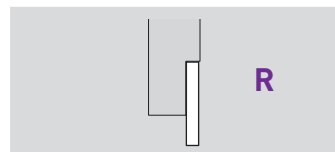
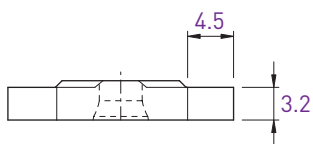
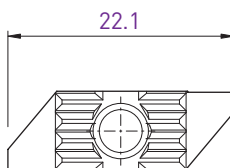

Art. N°	N (µm20)	AP302
251RFG-EP	■	■

APPLITEC

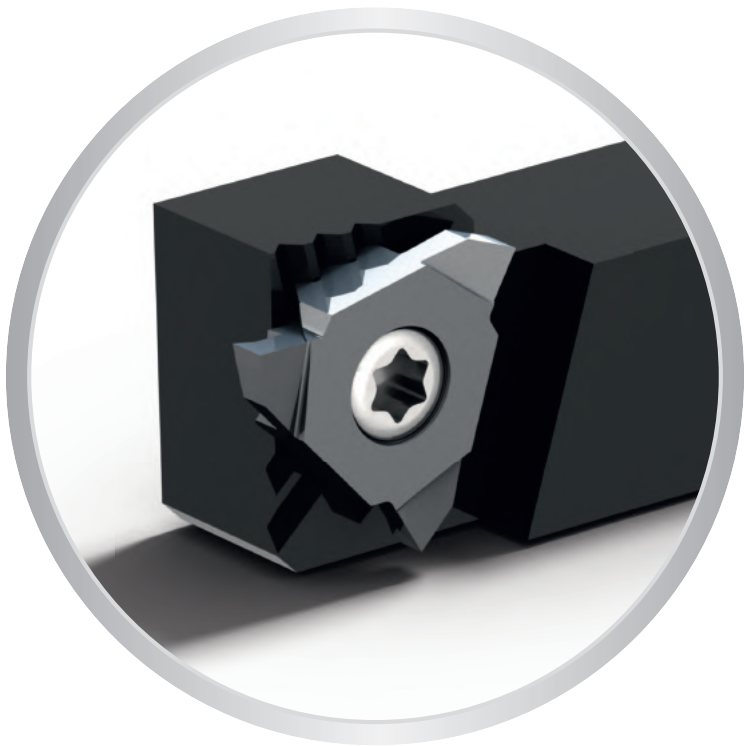



Nuances  
Sorten  
Grades

&gt; 5.02

Conseils d'utilisation - Accessoires  
Anwendungsempfehlungen - Zubehör  
Application recommendations - Accessories



&gt; 5.03

Porte-outils  
Halter  
Holders

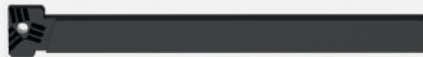

&gt; 5.04

**GX**

Gorge de précision  
Präzisionseinstechen  
High precision grooving

DIN6799  
& DIN471



&gt; 5.05

**FT**

Tournage finition  
Schlicht drehen  
Fine turning



&gt; 5.06

**GT**

Fonçage-tournage  
Einstechen und drehen  
Grooving and turning



&gt; 5.07

**GTX**

Fonçage-tournage avec coupe positive  
Einstechen und drehen mit positivem Spanwinkel  
Grooving and turning with positive cut



&gt; 5.08

**EP**

Plaquettes ébauches  
WSP-Rohlinge  
Blank inserts



&gt; 5.09

*Rigid clamping system with the famous Applitec teeth clamping*

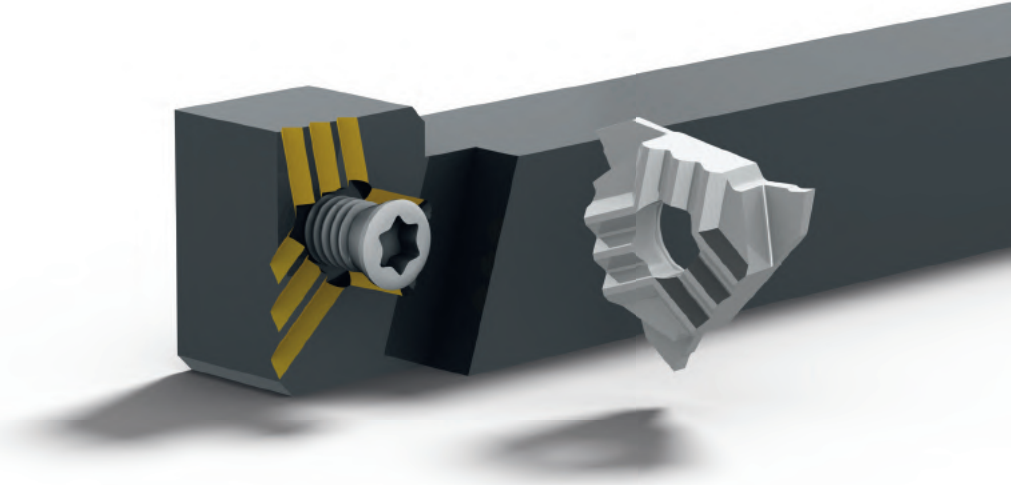

**Nuances micro-grain à dureté élevée**

**Verschleissfeste Feinkornsorten**

**Wear resistant micro-grain grades**

### HTA

μK10 + revêtement PVD  
μK10 + PVD Beschichtung  
μK10 + PVD coating

- nuance très résistante à l'usure
- pour l'usinage en finition dans des conditions favorables des aciers, aciers inoxydables et alliages de titane

- sehr verschleissfeste Sorte
- für die Feinbearbeitung von Stahl, rostfreiem Stahl und Titanlegierungen bei guten Bearbeitungsbedingungen

- very wear resistant grade
- for light machining of steel, stainless steel and titanium alloys under favourable machining conditions

### HN (μK10)

non revêtu  
unbeschichtet  
uncoated

- nuance micro-grain très résistante à l'usure
- recommandé pour l'usinage du laiton, de l'aluminium et du titane faiblement allié

- sehr verschleissfeste Feinkornsorte
- für die Bearbeitung von Messing und niedrig legiertem Aluminium und Titan empfehlenswert

- very wear resistant micro-grain grade
- suitable for the machining of brass and low alloyed aluminium and titanium

## Paramètres de coupe indicatifs

## Empfohlene Schnittwerte

## Standard machining data

Matière Werkstoff Material	Tournage Drehen Turning		Foncer Einstechen Grooving		
	VC (m/min)	F (mm/U)	VC (m/min)	F (mm/U)	
Acier de décolletage Automatenstahl Free-cutting steel	<b>P</b>	120 - 200	0.01 - 0.20	80 - 150	0.01 - 0.15
Acier Stahl Steel < 600 N/mm <sup>2</sup>	<b>P</b>	80 - 160	0.01 - 0.18	70 - 120	0.01 - 0.12
Acier Stahl Steel < 800 N/mm <sup>2</sup>	<b>P</b>	60 - 120	0.01 - 0.15	60 - 100	0.01 - 0.10
Acier Stahl Steel > 800 N/mm <sup>2</sup>	<b>P</b>	50 - 100	0.01 - 0.12	40 - 80	0.01 - 0.08
Acier inoxydable Rostfreistahl Stainless steel	<b>M</b>	60 - 120	0.01 - 0.15	60 - 100	0.01 - 0.08
Aluminium	<b>N</b>	180 - 800	0.01 - 0.30	150 - 300	0.01 - 0.20
Cuivre, laiton, bronze Kupfer, Messing, Bronze Copper, brass, bronze	<b>N</b>	100 - 500	0.01 - 0.30	100 - 300	0.01 - 0.20
Titane Titan Titanium	<b>S</b>	30 - 70	0.01 - 0.12	30 - 50	0.01 - 0.06

## Accessoires

## Zubehöre

## Accessories

Porte-outils Halter Holders			
T216-H...	V-M4X9-T15	C-T15	SET-NM-TX15

Recommandation de serrage  
Drehmoment Empfehlung  
Clamping recommendation

3.0 Nm

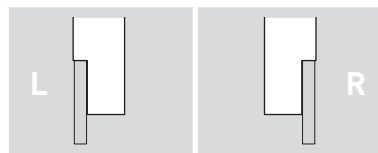
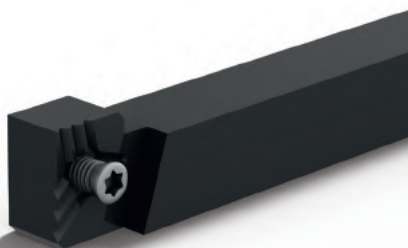
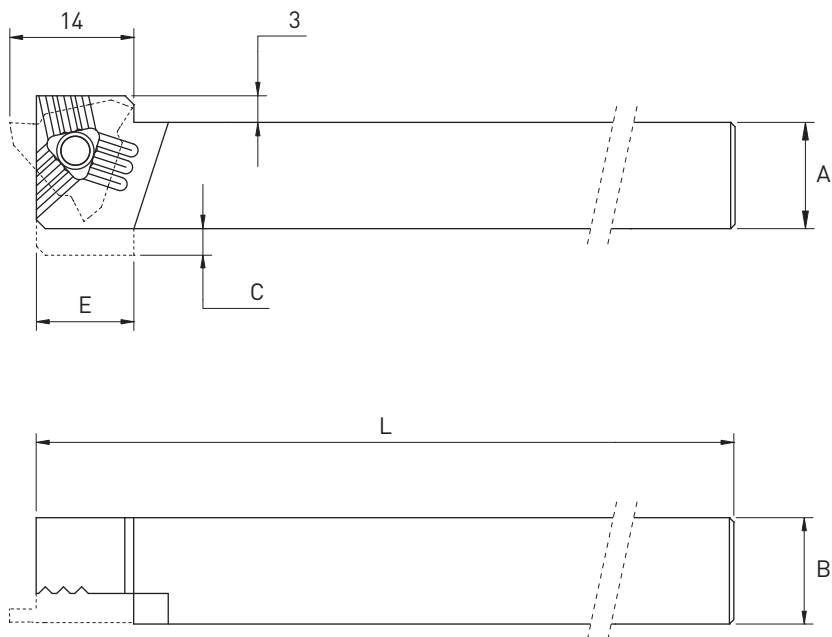

Chaque support est livré avec vis et clé.  
 Jeder Halter wird mit Spannschraube(n)  
 und Schlüssel geliefert.  
 Screw(s) and key are included with each  
 tool holder.

AxB	C	E	L	Art. N°	Art. N°
8x10	4	11	115	T216-H0810L	T216-H0810R
10x10	2	8	130	T216-H1010L	T216-H1010R
12x12	-	-	130	T216-H1212L	T216-H1212R
12x12	-	-	90	T216-H1212L-90	T216-H1212R-90
16x16	-	-	120	T216-H1616L	T216-H1616R
20x20	-	-	130	T216-H2020L	T216-H2020R

- Plaquettes de gorge pour circlips
- Einstechwendeplatte für Seegerring
- Grooving inserts for retaining ring

GX

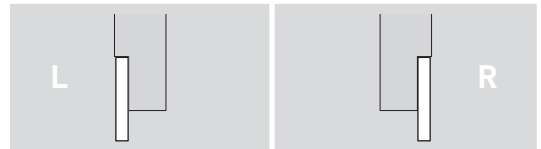
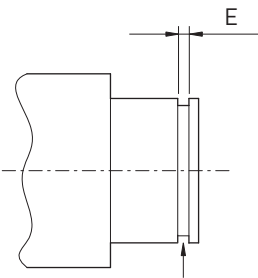
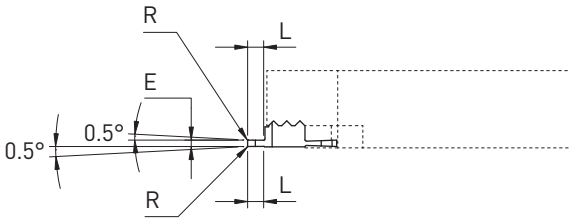
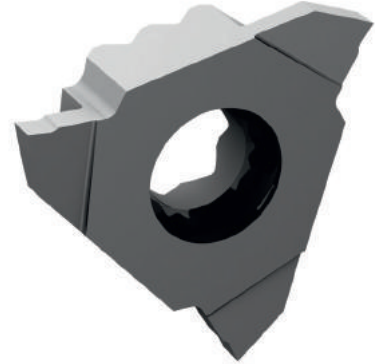
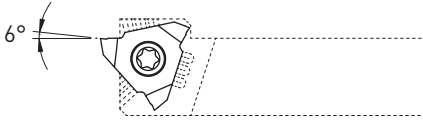

Selon DIN6799 et DIN471  
 Gemäss DIN6799 und DIN471  
 According to DIN6799 and DIN471



E ±0.01	L	R	L		R	
			Art. N°	HTA HN	Art. N°	HTA HN
0.26	0.8	0.03	T216L-GX026	■ ■	T216R-GX026	■ ■
0.36	0.8	0.03	T216L-GX036	■ ■	T216R-GX036	■ ■
0.46	0.8	0.03	T216L-GX046	■ ■	T216R-GX046	■ ■
0.50	1.5	0.03	T216L-GX050	■ ■	T216R-GX050	■ ■
0.57	1.5	0.03	T216L-GX057	■ ■	T216R-GX057	■ ■
0.67	1.5	0.03	T216L-GX067	■ ■	T216R-GX067	■ ■
0.77	2.0	0.03	T216L-GX077	■ ■	T216R-GX077	■ ■
0.87	2.0	0.03	T216L-GX087	■ ■	T216R-GX087	■ ■
0.97	2.5	0.03	T216L-GX097	■ ■	T216R-GX097	■ ■
1.00	2.5	0.03	T216L-GX100	■ ■	T216R-GX100	■ ■
1.10	2.5	0.03	T216L-GX110	■ ■	T216R-GX110	■ ■
1.20	2.5	0.03	T216L-GX120	■ ■	T216R-GX120	■ ■
1.30	2.5	0.03	T216L-GX130	■ ■	T216R-GX130	■ ■
1.50	2.5	0.03	T216L-GX150	■ ■	T216R-GX150	■ ■
1.60	2.5	0.03	T216L-GX160	■ ■	T216R-GX160	■ ■
1.85	2.5	0.03	T216L-GX185	■ ■	T216R-GX185	■ ■
2.00	2.5	0.03	T216L-GX200	■ ■	T216R-GX200	■ ■
2.50	2.5	0.03	T216L-GX250	■ ■	T216R-GX250	■ ■

# TRIO-LINE

Tournage avant  
Vorwärts drehen  
Front turning

FT

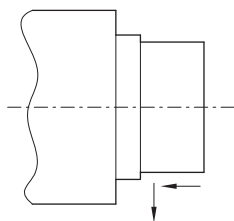
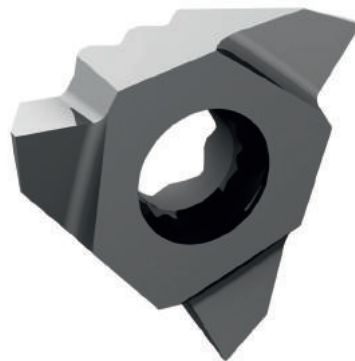
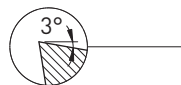
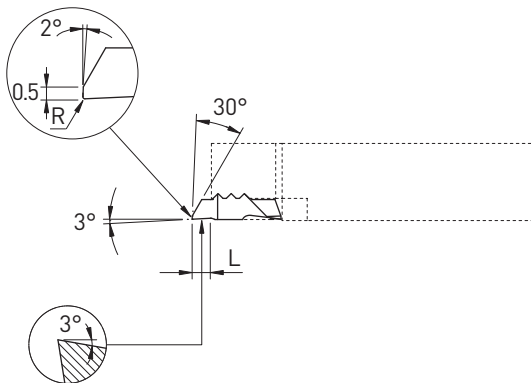
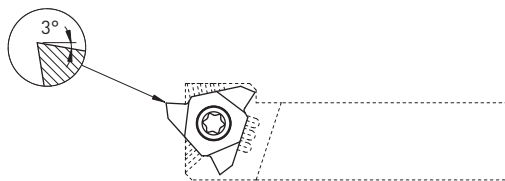

		L		R	
L	R	Art. N°	HTA HN	Art. N°	HTA HN
3.0	0.03	T216L-FT	■ ■	T216R-FT	■ ■
3.0	0.08	T216L-FT-R08	■ ■	T216R-FT-R08	■ ■

Fonçage-tournage

Einstecken und drehen

Grooving and turning

GT

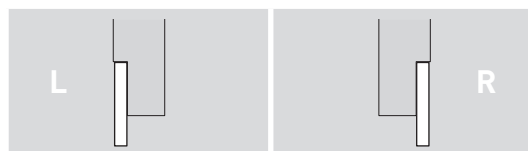
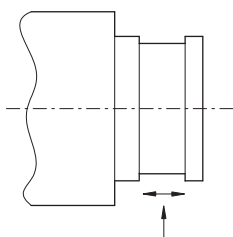
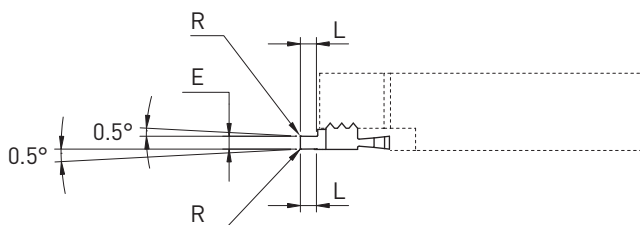
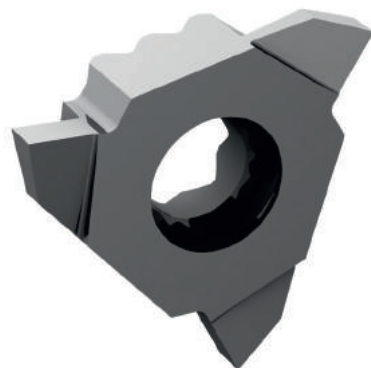
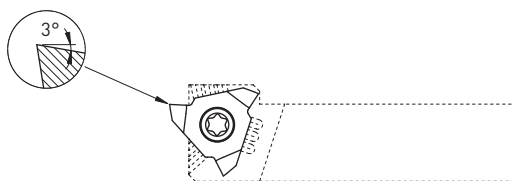

E	L	R	Art. N°	HTA		Art. N°	HN	
				■	■		■	■
0.5	1.5	0.03	T216L-GT050	■	■	T216R-GT050	■	■
1.0	2.5	0.03	T216L-GT100	■	■	T216R-GT100	■	■
1.0	2.5	0.08	T216L-GT100-R08	■	■	T216R-GT100-R08	■	■
1.5	2.5	0.03	T216L-GT150	■	■	T216R-GT150	■	■
1.5	2.5	0.08	T216L-GT150-R08	■	■	T216R-GT150-R08	■	■
1.5	2.5	0.15	T216L-GT150-R15	■	■	T216R-GT150-R15	■	■
2.0	2.5	0.03	T216L-GT200	■	■	T216R-GT200	■	■
2.0	2.5	0.08	T216L-GT200-R08	■	■	T216R-GT200-R08	■	■
2.0	2.5	0.15	T216L-GT200-R15	■	■	T216R-GT200-R15	■	■
2.5	2.5	0.15	T216L-GT250-R15	■	■	T216R-GT250-R15	■	■

# TRIO-LINE

Fonçage-tournage  
Einstecken und drehen  
Grooving and turning

GTX

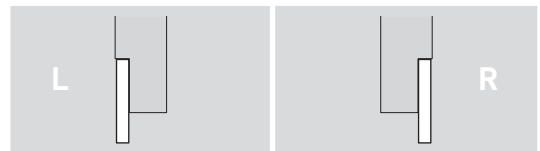
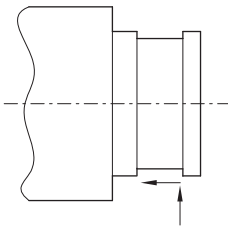
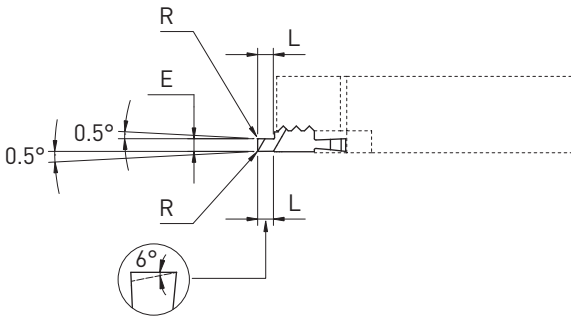
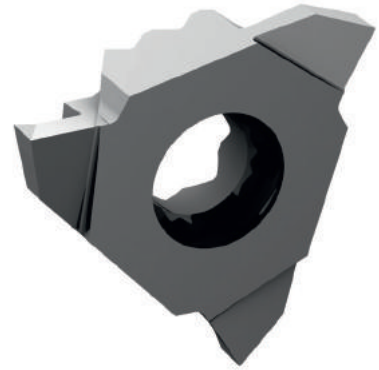
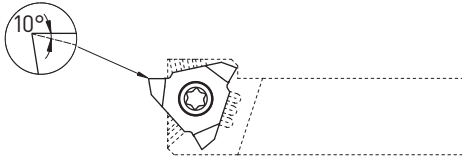

E	L	R	L		R	
			Art. N°	HTA HN	Art. N°	HTA HN
1.0	2.5	0.03	T216L-GTX100	■ ■	T216R-GTX100	■ ■
1.0	2.5	0.08	T216L-GTX100-R08	■ ■	T216R-GTX100-R08	■ ■
1.5	2.5	0.03	T216L-GTX150	■ ■	T216R-GTX150	■ ■
1.5	2.5	0.08	T216L-GTX150-R08	■ ■	T216R-GTX150-R08	■ ■
1.5	2.5	0.15	T216L-GTX150-R15	■ ■	T216R-GTX150-R15	■ ■
2.0	2.5	0.03	T216L-GTX200	■ ■	T216R-GTX200	■ ■
2.0	2.5	0.08	T216L-GTX200-R08	■ ■	T216R-GTX200-R08	■ ■
2.0	2.5	0.15	T216L-GTX200-R15	■ ■	T216R-GTX200-R15	■ ■
2.5	2.5	0.15	T216L-GTX250-R15	■ ■	T216R-GTX250-R15	■ ■



- Plaquettes ébauches
- WSP-Rohlinge
- Blank inserts

EP

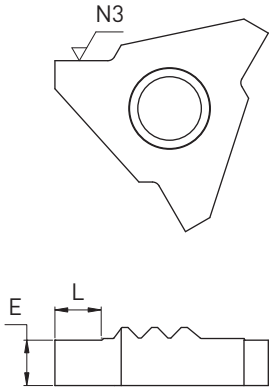

		L		R	
E	L	Art. N°	HTA HN	Art. N°	HTA HN
~3	3	T216L-EP	■	T216R-EP	■



### 300 Series

3 contact points

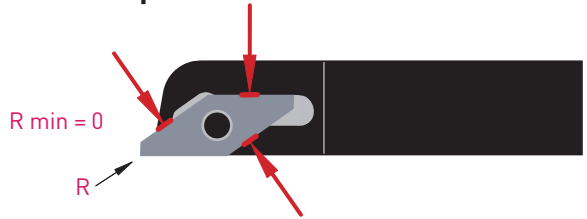

rigid clamping system

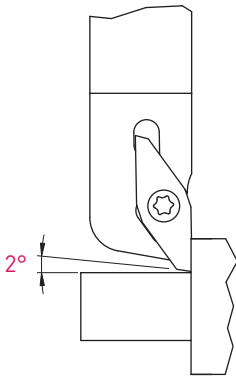

“wiper effect”

Pour un meilleur état de surface  
Für eine bessere Oberflächengüte  
For a better surface finish



Conseils d'utilisation et paramètres de coupe indicatifs  
 Anwendungsempfehlungen und empfohlene Schnittwerte  
 Application recommendations and standard machining data

&gt; 6.02

Tournage avant  
 Vorwärts drehen  
 Front turning

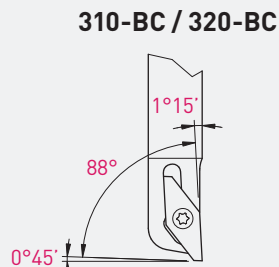
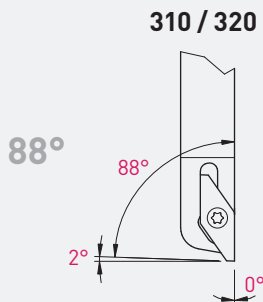

Tournage avant  
 Vorwärts drehen  
 Front turning

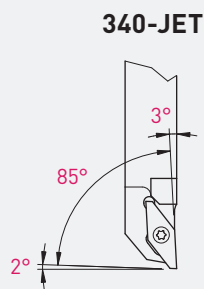
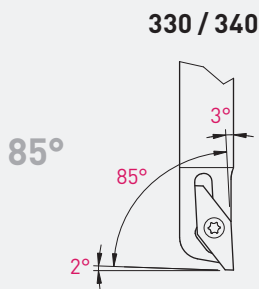







# TURN-LINE

Conseils d'utilisation

Anwendungsempfehlungen

Application recommendations

Géométries de coupe Spanformgeometrien Cutting geometry		P		M		N		S		★							
		Acier de décolletage Automatenstahl Free-cutting steel		Acier Stahl Steel		Acier inoxydable Rostfreistahl Stainless steel		Aluminium		Laiton, bronze Messing, Bronze Brass, bronze		Cuivre Kupfer Copper		Titane Titane Titanium		1 <sup>er</sup> choix 1. Wahl 1 <sup>st</sup> choice	
		★		★		★		★		★		★		★		Recommandé Empfohlen Recommended	
		★		★		★		★		★		★		★		Pour pièces fragiles de très petits diamètres Für empfindliche und sehr kleine Werkstücke For fragile and very small work pieces	
	3_7	★	★	★	★	★			★	★				Géométrie universelle, très bonne maîtrise du copeau Allgemeine Geometrie, sehr gute Spankontrolle All-round insert with efficient chip control			
	3_7-EN	☆	★	☆										Arête renforcée (augmente l'effort de coupe) Verstärkte Schneidkante (Schneidkraftehöhung) Reinforced cutting edge (increases cutting force) f min: 0.02 mm/U			
	3_8	☑	☑	☑				★						Géométrie plate classique Standard flache Geometrie Standard flat geometry			
	3_8VS	☆		☆		☑				☑	☑			Brise-copeau pour usinage léger en finition Spanbrecher für leichte Schlichtbearbeitung Chip-breaker for light finishing operation			
	3_8VX	★	★	★	★					★	★			Très bonne maîtrise du copeau Sehr gute Spankontrolle Very efficient chip control			
	3_8X	★	★	★	☆					☆	★			Coupe positive traditionnelle Standard positive Geometrie Standard positive geometry			
	3_9	☆	☆	☆				☆						Témoin plat sur la coupe pour réduire les vibrations Vibrationsreduzierung durch einer Flachfase und der Schneidkante Vibration reduction through flat ended cutting edge			

## Nuances micro-grain à dureté élevée

## Verschleissfeste Feinkornsorten

## Wear resistant micro-grain grades

<p><b>P</b> <b>M</b> <b>N</b> <b>S</b></p> <h2>TiAlN</h2> <p>μK20 + revêtement PVD μK20 + PVD Beschichtung μK20 + PVD coating</p>	<p><b>P</b> <b>M</b> <b>N</b> <input type="checkbox"/></p> <h2>TiN</h2> <p>μK20 + revêtement PVD μK20 + PVD Beschichtung μK20 + PVD coating</p>	<p><b>P</b> <b>M</b> <input type="checkbox"/> <b>S</b></p> <h2>TiAlX</h2> <p>μK20 + revêtement PVD μK20 + PVD Beschichtung μK20 + PVD coating</p>	<p><b>P</b> <input type="checkbox"/> <b>N</b> <b>S</b></p> <h2>N (μK20)</h2> <p>non revêtu unbeschichtet uncoated</p>
<ul style="list-style-type: none"> <li>excellente nuance universelle</li> <li>1<sup>er</sup> choix pour l'usinage des aciers, aciers inoxydables et alliages de titane</li> <li>très bonne résistance à la température</li> </ul>	<ul style="list-style-type: none"> <li>nuance pour l'usinage des matières peu résistantes qui créent des arêtes rapportées</li> <li>très faible coefficient de frottement</li> <li>à éviter pour l'usinage du titane</li> </ul>	<ul style="list-style-type: none"> <li>nuance très résistante à l'usure et à la température, recommandée pour l'usinage des matières suivantes: Inox 304, 316L, 317L, 904, Phynox</li> <li>aciers alliés contenant: Chrome Nickel, Vanadium, Molybdène, ...</li> </ul>	<ul style="list-style-type: none"> <li>supporte les coupes interrompues et autres conditions d'usinage défavorables</li> </ul>
<ul style="list-style-type: none"> <li>beste Universalsorte</li> <li>für die Bearbeitung von Stahl, rostfreiem Stahl und Titanlegierungen bestens geeignet</li> <li>sehr gute Warmfestigkeit</li> </ul>	<ul style="list-style-type: none"> <li>Sorte für die Bearbeitung von weichen Werkstoffen mit Tendenz zur Bildung von Aufbauschneiden</li> <li>sehr geringer Reibwert</li> <li>für die Bearbeitung von Titan nicht geeignet</li> </ul>	<ul style="list-style-type: none"> <li>sehr verschleissfeste und temperaturbeständige Sorte. Für folgende Materialien empfohlen: Inox 304, 316L, 317L, 904, Phynox</li> <li>legierter Stahl enthaltend: Chrom-Nickel, Vanadium, Molybdän, ...</li> </ul>	<ul style="list-style-type: none"> <li>für unterbrochene Schnitte und andere ungünstige Bearbeitungsbedingungen geeignet</li> </ul>
<ul style="list-style-type: none"> <li>best universal grade</li> <li>first choice for steel, stainless steel and titanium alloys machining</li> <li>very good heat resistance</li> </ul>	<ul style="list-style-type: none"> <li>grade for the machining of low resistance materials which causes edge build-up</li> <li>very low friction ratio</li> <li>not suitable for titanium machining</li> </ul>	<ul style="list-style-type: none"> <li>very wear and high temperature resistant grade. Recommended for following material: Inox 304, 316L, 317L, 904, Phynox</li> <li>alloy steel containing: Chrome-nickel, Vanadium, Molybdenum, ...</li> </ul>	<ul style="list-style-type: none"> <li>suitable for interrupted cut and other unfavourable machining conditions</li> </ul>
<p><b>P</b> <b>M</b> <b>N</b> <b>S</b></p> <h2>HTA</h2> <p>μK10 + revêtement PVD μK10 + PVD Beschichtung μK10 + PVD coating</p>	<p><b>P</b> <b>M</b> <b>N</b> <input type="checkbox"/></p> <h2>HTiN</h2> <p>μK10 + revêtement PVD μK10 + PVD Beschichtung μK10 + PVD coating</p>	<p><b>P</b> <b>M</b> <input type="checkbox"/> <b>S</b></p> <h2>HTAX</h2> <p>μK10 + revêtement PVD μK10 + PVD Beschichtung μK10 + PVD coating</p>	<p><b>P</b> <input type="checkbox"/> <b>N</b> <b>S</b></p> <h2>HN (μK10)</h2> <p>non revêtu unbeschichtet uncoated</p>
<ul style="list-style-type: none"> <li>nuance très résistante à l'usure</li> <li>pour l'usinage en finition dans des conditions favorables des aciers, aciers inoxydables et alliages de titane</li> </ul>	<ul style="list-style-type: none"> <li>nuance pour l'usinage en finition des matières peu résistantes qui créent des arêtes rapportées</li> <li>très faible coefficient de frottement</li> <li>à éviter pour l'usinage du titane</li> </ul>	<ul style="list-style-type: none"> <li>nuance très résistante à l'usure et à la température, pour l'usinage en finition avec faible avance de petites pièces. Recommandée pour l'usinage des matières suivantes: Inox 304, 316L, 317L, 904, Phynox</li> <li>aciers alliés contenant: Chrome Nickel, Vanadium, Molybdène, ...</li> </ul>	<ul style="list-style-type: none"> <li>nuance micro-grain très résistante à l'usure</li> <li>recommandé pour l'usinage du titane faiblement allié</li> <li>déconseillé en cas de coupe interrompue et autres conditions d'usinage défavorables</li> </ul>
<ul style="list-style-type: none"> <li>sehr verschleissfeste Sorte</li> <li>für die Feinbearbeitung von Stahl, rostfreiem Stahl und Titanlegierungen bei guten Bearbeitungsbedingungen</li> </ul>	<ul style="list-style-type: none"> <li>Sorte für die Feinbearbeitung von weichen Werkstoffen mit Tendenz zur Bildung von Aufbauschneiden</li> <li>sehr geringer Reibwert</li> <li>für die Bearbeitung von Titan nicht geeignet</li> </ul>	<ul style="list-style-type: none"> <li>sehr verschleissfeste und temperaturbeständige Sorte, für Feinbearbeitung von kleinen Teilen mit geringer Vorschub. Für folgende Materialien empfohlen: Inox 304, 316L, 317L, 904, Phynox</li> <li>legierter Stahl enthaltend: Chrom-Nickel, Vanadium, Molybdän, ...</li> </ul>	<ul style="list-style-type: none"> <li>verschleissfeste Feinkornsorte</li> <li>für die Bearbeitung von niedrig legiertem Titan empfehlenswert</li> <li>für unterbrochene Schnitte und andere ungünstige Bearbeitungsbedingungen nicht geeignet</li> </ul>
<ul style="list-style-type: none"> <li>very wear resistant grade</li> <li>for light machining of steel, stainless steel and titanium alloys under favourable machining conditions</li> </ul>	<ul style="list-style-type: none"> <li>grade for light machining of low resistance materials which causes edge build-up</li> <li>very low friction ratio</li> <li>not suitable for titanium machining</li> </ul>	<ul style="list-style-type: none"> <li>very wear and high temperature resistant grade, for light machining of small parts with low cutting feed. Recommended for following material: Inox 304, 316L, 317L, 904, Phynox</li> <li>alloy steel containing: Chrome-nickel, Vanadium, Molybdenum, ...</li> </ul>	<ul style="list-style-type: none"> <li>wear resistant micro-grain grade</li> <li>suitable for the machining of low alloyed titanium</li> <li>not suitable for interrupted cut and other unfavourable machining conditions</li> </ul>

# TURN-LINE

Paramètres de coupe indicatifs

Empfohlene Schnittwerte

Standard machining data

Matière Werkstoff Material	Tournage Drehen Turning		
	VC	Prof. de passe Schnitttiefe Depth of cut	Avance Vorschub Feed
	(m/min)	(mm)	(mm/U)
Acier de décolletage Automatenstahl Free-cutting steel <span style="float: right;">(P)</span>	120 - 200	0.05 - 1.0 1.0 - 4.0	0.01 - 0.15 0.05 - 0.25
Acier Stahl Steel < 600 N/mm <sup>2</sup> <span style="float: right;">(P)</span>	80 - 160	0.05 - 1.0 1.0 - 4.0	0.01 - 0.15 0.05 - 0.25
Acier Stahl Steel < 800 N/mm <sup>2</sup> <span style="float: right;">(P)</span>	60 - 120	0.05 - 1.0 1.0 - 4.0	0.01 - 0.10 0.05 - 0.20
Acier Stahl Steel > 800 N/mm <sup>2</sup> <span style="float: right;">(P)</span>	50 - 100	0.05 - 1.0 1.0 - 3.0	0.01 - 0.08 0.05 - 0.15
Acier inoxydable Rostfreistahl Stainless steel <span style="float: right;">(M)</span>	60 - 120	0.05 - 1.0 1.0 - 3.0	0.01 - 0.08 0.05 - 0.15
Aluminium Si <12% <span style="float: right;">(N)</span>	200 - 1000	0.05 - 1.0 1.0 - 4.0	0.01 - 0.20 0.05 - 0.40
Aluminium Si >12% <span style="float: right;">(N)</span>	180 - 800	0.05 - 1.0 1.0 - 4.0	0.01 - 0.20 0.05 - 0.40
Cuivre, laiton, bronze Kupfer, Messing, Bronze Copper, brass, bronze <span style="float: right;">(N)</span>	100 - 500	0.05 - 1.0 1.0 - 4.0	0.01 - 0.20 0.05 - 0.35
Titane Titan Titanium <span style="float: right;">(S)</span>	30 - 70	0.05 - 1.0 1.0 - 4.0	0.01 - 0.08 0.05 - 0.15

**Indications pour premier réglage**  
**Hinweise für die erste Einrichtung**  
**Indications for first setting**

<b>Ébauche</b> <b>Schruppen</b> <b>Roughing</b>	<b>Finition</b> <b>Schlichten</b> <b>Finishing</b>
<ul style="list-style-type: none"> <li>• vitesse de coupe moyenne</li> <li>• avance élevée</li> </ul>	<ul style="list-style-type: none"> <li>• vitesse de coupe élevée</li> <li>• avance faible</li> </ul>
<ul style="list-style-type: none"> <li>• durchschnittliche Schnittgeschwindigkeit</li> <li>• hohe Schnittgeschwindigkeit</li> </ul>	<ul style="list-style-type: none"> <li>• hohe Schnittgeschwindigkeit</li> <li>• niedriger Vorschub</li> </ul>
<ul style="list-style-type: none"> <li>• average cutting feed</li> <li>• high cutting feed</li> </ul>	<ul style="list-style-type: none"> <li>• high cutting feed</li> <li>• low cutting feed</li> </ul>

**Remarques importantes**  
**Wichtige Bemerkungen**  
**Important remarks**

- en raison des limites de la machine, il n'est souvent pas possible d'atteindre les vitesses de coupe préconisées
- les outils Applitec sont spécialement développés pour permettre de hautes performances, même dans des conditions de coupe défavorables
- des applications non préconisées dans le tableau ci-contre peuvent également s'avérer efficaces

- wegen begrenzter Maschinenleistung ist es oft nicht möglich, die vorgeschlagenen Schnittgeschwindigkeiten zu erreichen
- Applitec Werkzeuge sind besonders dazu entwickelt, um sogar bei ungünstigen Schnittdaten leistungsfähig zu sein
- die in der nebenstehender Tabelle nicht erwähnten Anwendungsfälle können sich auch effizient erweisen

- in many cases, it is impossible to reach the recommended cutting speed, due to the machine limits
- Applitec tools are especially designed to be efficient even in bad cutting conditions
- applications not mentioned in the opposite table can also be efficient

# TURN-LINE

Porte-outils

Halter

Holder

88°

310 / 320

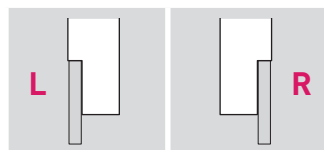
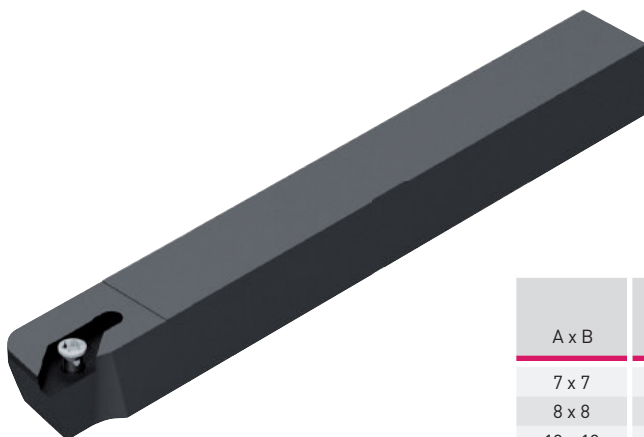
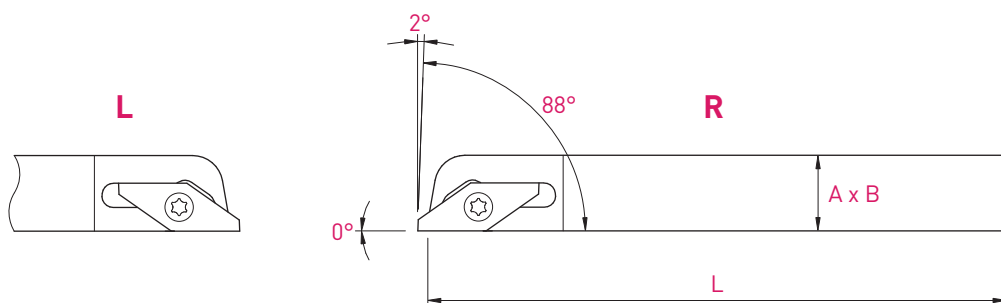

A x B	L	Art. N°	Art. N°
7 x 7	115	310-7	320-7
8 x 8	115	310-8	320-8
10 x 10	115	310-10	320-10
10 x 10	140	-	320-10-140
12 x 12	115	310-12	320-12
12 x 12	90	310-12-90	320-12-90
12 x 12	140	310-12-140	320-12-140
12.7 x 12.7	140	310-12.7	320-12.7
16 x 16	100	310-16	320-16
16 x 16	140	310-16-140	320-16-140
20 x 20	120	310-20	320-20



Porte-outils

Halter

Holder

88°

310-BC / 320-BC

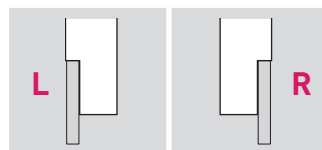
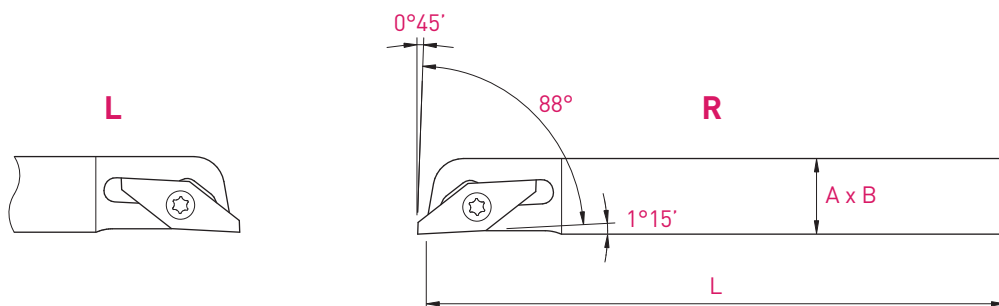

A x B	L	Art. N°	Art. N°
7 x 7	115	310-7-BC	320-7-BC
8 x 8	115	310-8-BC	320-8-BC
10 x 10	115	310-10-BC	320-10-BC
10 x 10	140	-	320-10-140-BC
12 x 12	115	310-12-BC	320-12-BC
12 x 12	90	310-12-90-BC	320-12-90-BC
12 x 12	140	310-12-140-BC	320-12-140-BC
12.7 x 12.7	140	310-12.7-BC	320-12.7-BC
16 x 16	100	310-16-BC	320-16-BC
16 x 16	140	310-16-140-BC	320-16-140-BC
20 x 20	120	310-20-BC	320-20-BC

Porte-outils Halter Holder	Serrage standard (A) Standard Spannsystem (A) Standard clamping system (A)
311 / 321	V-M2.5X6.5-T8
312 - 316	V-M2.5X7.8-T8
322 - 326	C-T8

Chaque support est livré avec vis et clé.  
Jeder Halter wird mit Spannschraube(n) und Schlüssel geliefert.  
Screw(s) and key are included with each tool holder.

# TURN-LINE

Tournage avant  
Vorwärts drehen  
Front turning

88°

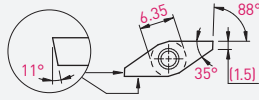

310 / 320

## 317 / 327

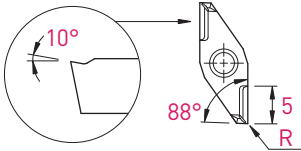

R	Art. N°	L						Art. N°	R					
		TiAlN	TiN	N (µk20)	HTA	HTiN	HN (µk10)		TiAlN	TiN	N (µk20)	HTA	HTiN	HN (µk10)
0	317	■	■	■	■	■	■	327	■	■	■	■	■	■
0.03	317-R03	■	■	■	■	■	■	327-R03	■	■	■	■	■	■
0.08	317-R08	■	■	■	■	■	■	327-R08	■	■	■	■	■	■
0.10	317-R10	■	■	■	■	■	■	327-R10	■	■	■	■	■	■
0.20	317-R20	■	■	■	■	■	■	327-R20	■	■	■	■	■	■

## 318 / 328

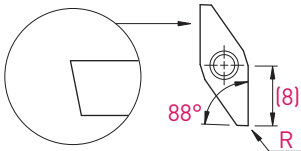

R	Art. N°	L			Art. N°	R		
		HTA	HTiN	HN (µk10)		HTA	HTiN	HN (µk10)
0	318	■	■	■	328	■	■	■
0.05	318-R05	■	■	■	328-R05	■	■	■
0.10	318-R10	■	■	■	328-R10	■	■	■
0.20	318-R20	■	■	■	328-R20	■	■	■
0.40	318-R40	■	■	■	328-R40	■	■	■

## 318VS / 328VS

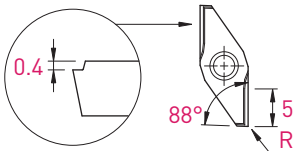

R	Art. N°	L			Art. N°	R		
		HTA	HTiN	HN (µk10)		HTA	HTiN	HN (µk10)
0	318VS	■	■	■	328VS	■	■	■
0.10	318VS-R10	■	■	■	328VS-R10	■	■	■

Tournage avant  
Vorwärts drehen  
Front turning

88°

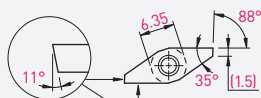

310 / 320

318VX / 328VX

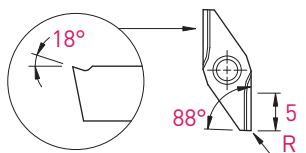

R	Art. N°	L			R		
		HTA	HTiN	HN (µk10)	HTA	HTiN	HN (µk10)
0	318VX	■	■	■	■	■	■
0.05	318VX-R05	■	■	■	■	■	■
0.10	318VX-R10	■	■	■	■	■	■
0.20	-				■	■	■
0.40	-				■	□	■

318X / 328X

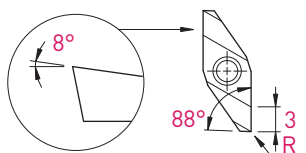

R	Art. N°	L			R		
		HTA	HTiN	HN (µk10)	HTA	HTiN	HN (µk10)
0	318X	■	■	■	■	■	■
0.10	318X-R10	■	■	■	■	■	■

319 / 329

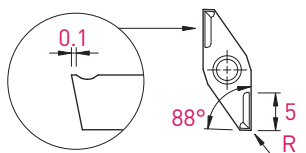

R	Art. N°	L			R		
		HTA	HTiN	HN (µk10)	HTA	HTiN	HN (µk10)
0	319	■	■	■	■	■	■
0.10	319-R10	■	■	■	■	■	■
0.20	319-R20	■	■	■	■	■	■

■ = disponible / verfügbar / available  
□ = selon disponibilité du stock / jenach Lagerverfügbarkeit / depending on stock availability

# TURN-LINE

Porte-outils

Halter



Holder

85°

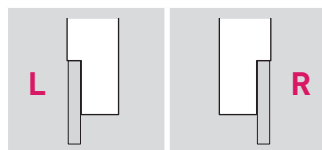
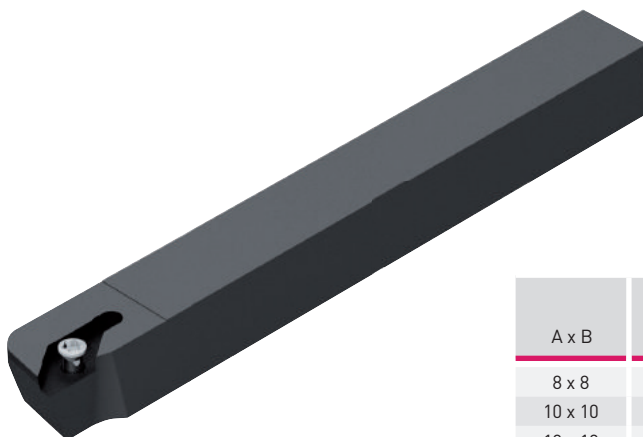
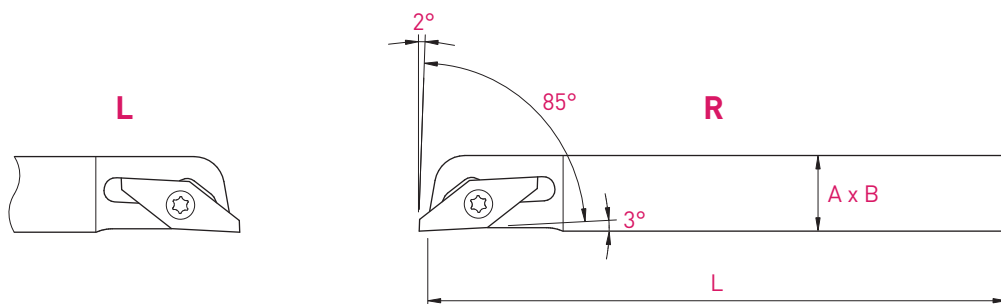
330 / 340



A x B	L	Art. N°	Art. N°
8 x 8	115	330-8	340-8
10 x 10	115	330-10	340-10
10 x 10	140	-	340-10-140
12 x 12	115	330-12	340-12
12 x 12	90	330-12-90	340-12-90
12 x 12	140	330-12-140	340-12-140
12.7 x 12.7	140	330-12.7	340-12.7
16 x 16	100	330-16	340-16
16 x 16	140	330-16-140	340-16-140
20 x 20	120	330-20	340-20

Porte-outils Halter Holder	Serrage standard (A) Standard Spannsystem (A) Standard clamping system (A)	
		
332 - 336 342 - 346	V-M2.5X7.8-T8	C-T8

Chaque support est livré avec vis et clé.  
Jeder Halter wird mit Spannschraube(n) und Schlüssel geliefert.  
Screw(s) and key are included with each tool holder.

Porte-outils avec arrosage intégré  
 Halter mit integrierter Kühlmittelzufuhr  
 Holders with integrated coolant supply

85°

340-JET

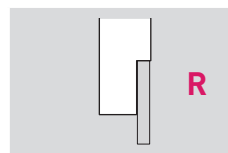
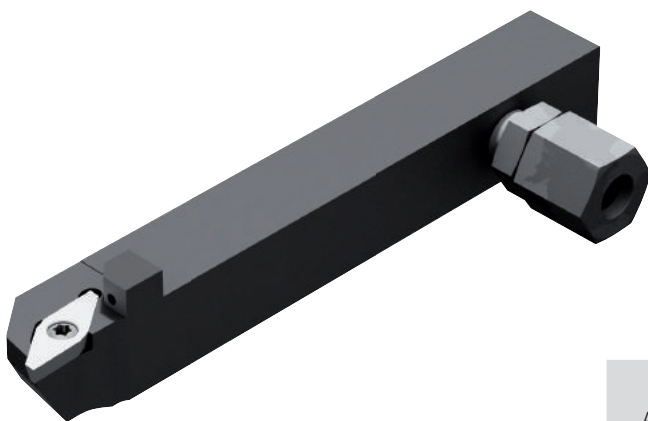
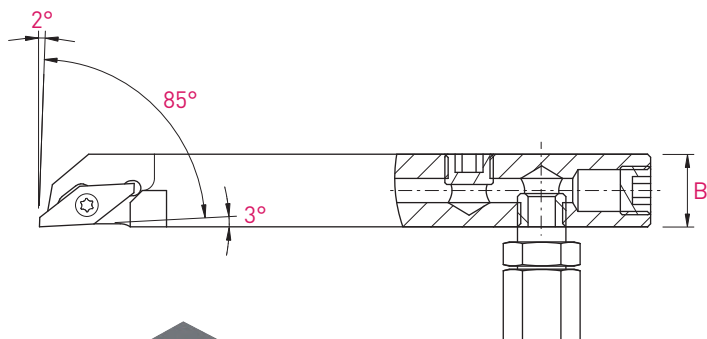
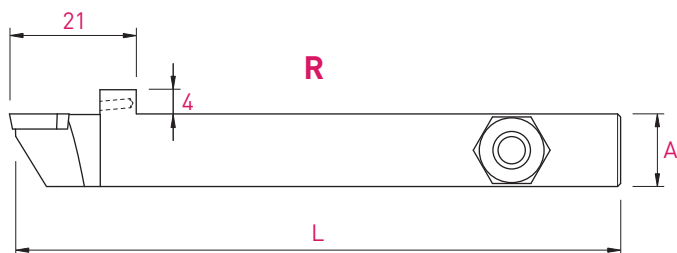

Pièces de rechange Ersatzteile Spare parts	Option		
	Art. N°	Art. N°	Art. N°
340-0810-JET	J-M5-D5	JC-M5-D5	JB-M5
340-JET	J-M8X1-D6	-	JB-M8X1

A x B	L	Art. N°
8 x 10	100	340-0810-JET
10 x 12	100	340-1012-JET
12 x 12	100	340-12-JET
12.7 x 12.7	100	340-12.7-JET
16 x 16	100	340-16-JET
20 x 20	100	340-20-JET

Chaque support est livré avec vis et clé.  
 Jeder Halter wird mit Spannschraube(n) und Schlüssel geliefert.  
 Screw(s) and key are included with each tool holder.

# TURN-LINE

Tournage avant  
Vorwärts drehen  
Front turning

85°

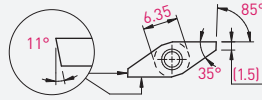

330 / 340

## 337 / 347

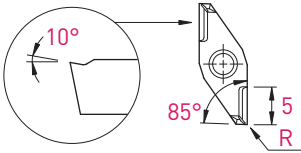

R	Art. N°	L							R							
		TiAlN	TiAlX	TiN	N [μk20]	HTA	HTiN	HN [μk10]	TiAlN	TiAlX	TiN	N [μk20]	HTA	HTiN	HN [μk10]	
0	337	■	■	■	■	■	■	■	347	■	■	■	■	■	■	■
0.03	337-R03	■	■	■	■	■	■	■	347-R03	■	■	■	■	■	■	■
0.08	337-R08	■	■	■	■	■	■	■	347-R08	■	■	■	■	■	■	■
0.10	337-R10	■	■	■	■	■	■	■	347-R10	■	■	■	■	■	■	■
0.20	337-R20	■	■	■	■	■	■	■	347-R20	■	■	■	■	■	■	■
0.35	-	■	■	■	■	■	■	■	347-R35	■	■	■	■	■	■	■
0	337-EN	■	■	■	■	■	■	■	347-EN	■	■	■	■	■	■	■
0.03	337-EN-R03	■	■	■	■	■	■	■	347-EN-R03	■	■	■	■	■	■	■
0.08	337-EN-R08	■	■	■	■	■	■	■	347-EN-R08	■	■	■	■	■	■	■
0.10	337-EN-R10	■	■	■	■	■	■	■	347-EN-R10	■	■	■	■	■	■	■
0.20	337-EN-R20	■	■	■	■	■	■	■	347-EN-R20	■	■	■	■	■	■	■
0.35	-	■	■	■	■	■	■	■	347-EN-R35	■	■	■	■	■	■	■

## 338 / 348

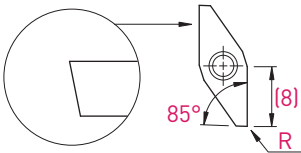

R	Art. N°	L			R			
		HTA	HTiN	HN [μk10]	HTA	HTiN	HN [μk10]	
0	338	■	■	■	348	■	■	■
0.05	338-R05	■	■	■	348-R05	■	■	■
0.10	338-R10	■	■	■	348-R10	■	■	■
0.20	338-R20	■	■	■	348-R20	■	■	■
0.40	338-R40	■	■	■	348-R40	■	■	■

## 338VS / 348VS

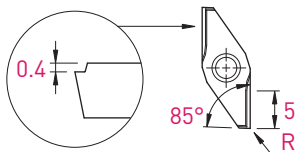

R	Art. N°	L			R			
		HTA	HTiN	HN [μk10]	HTA	HTiN	HN [μk10]	
0	338VS	■	■	■	348VS	■	■	■
0.10	338VS-R10	■	■	■	348VS-R10	■	■	■

Tournage avant  
Vorwärts drehen  
Front turning

85°

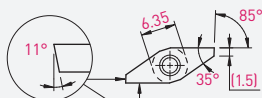

330 / 340

338VX / 348VX

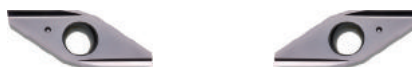
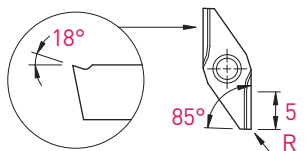

R	Art. N°	L			R		
		HTA	HTiN	HN (µk10)	HTA	HTiN	HN (µk10)
0	338VX	■	■	■	■	■	■
0.05	338VX-R05	■	■	■	■	■	■
0.10	338VX-R10	■	■	■	■	■	■

338X / 348X

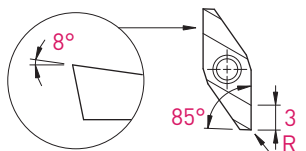

R	Art. N°	L			R		
		HTA	HTiN	HN (µk10)	HTA	HTiN	HN (µk10)
0	338X	■	■	■	■	■	■
0.10	338X-R10	■	■	■	■	■	■

339 / 349

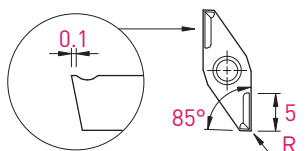

R	Art. N°	L			R		
		HTA	HTiN	HN (µk10)	HTA	HTiN	HN (µk10)
0	339	■	■	■	■	■	■
0.10	339-R10	■	■	■	■	■	■
0.20	339-R20	■	■	■	■	■	■

■ = disponible / verfügbar / available  
□ = selon disponibilité du stock / jenach Lagerverfügbarkeit / depending on stock availability

APPLITEC





Index

Codification des outils ISO-Line  
ISO-Line Bezeichnungssystem  
ISO-Line designation system

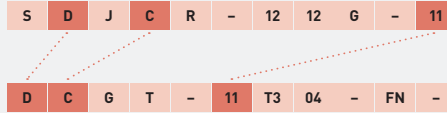

> 7.02

Géométries de coupe  
Spanformgeometrien  
Cutting geometries



> 7.05

Nuances  
Sorten  
Grades



> 7.11

Porte-outils  
et plaquettes 80°  
Halter und  
WSP 80°  
Holders and  
inserts 80°

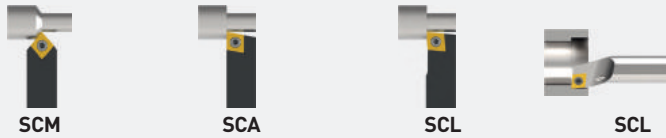

> 7.13

Porte-outils  
et plaquettes 55°  
Halter und  
WSP 55°  
Holders and  
inserts 55°

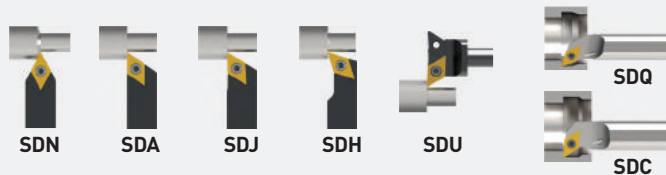

> 7.27

Porte-outils  
et plaquettes 35°  
Halter und  
WSP 35°  
Holders and  
inserts 35°



> 7.45

Pièces de rechange et accessoires  
Ersatzteile und Zubehör  
Spare parts and accessories



> 7.61

Paramètres de coupe  
Schnittwerte  
Machining data

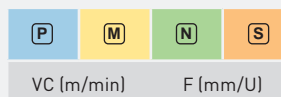

> 7.62

# ISO-LINE

## Codification des porte-outils ISO-Line

## ISO-Line Bezeichnungssystem für Halter

## ISO-Line designation system for holders

Méthode de serrage Klemmsystem Clamping system	Forme de la plaquette Plattenform Insert shape	Géométrie du porte-outil Halterform Holder geometry	Angle de dépointe de la plaquette WSP-Freiwinkel Insert clearance angle	Direction de coupe Schneidrichtung Cut direction		Hauteur du porte-outil Halter Höhe Holder height	Largeur du porte-outil Halter-Breite Holder width	Longueur du porte-outil Halter-Länge Holder length		Dimension de la plaquette (L) WSP-Größe (L) Insert size (L)
--	--	---	---	--	--	--	---	--	--	---

**S D J C R - 12 12 G - 11**

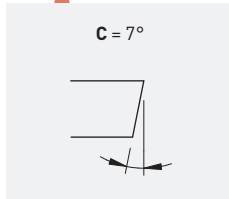
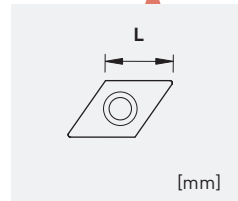
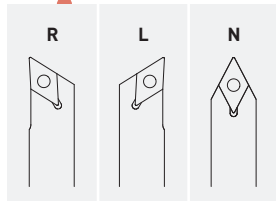

**A x B (or Ø) [mm]**

- 08 x 08
- 10 x 10
- 12 x 12
- 12.7 x 12.7 (1/2 in)
- 16 x 16
- 20 x 20
- Ø: D10 / D20 / D25.4 (Ø1 in)

**Length: [mm]**

- F = 75
- G = 90
- J = 110
- X = Special

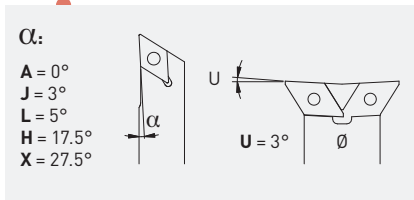

**α:**

- A = 0°
- J = 3°
- L = 5°
- H = 17.5°
- X = 27.5°

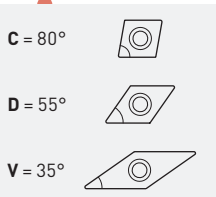

**S =** vis  
Schraube  
screw



**Compatibilité porte-outil - plaquette**  
WSP - Halter Kompatibilität  
Holder - insert compatibility

S	D	J	C	R	-	12	12	G	-	11
D	C	G	T	-	11	T3	04	-	FN	-

**Codification des porte-outils ISO-Line**  
**ISO-Line Bezeichnungssystem für Halter**  
**ISO-Line designation system for holders**

Méthode de serrage Klemmsystem Clamping system	Largeur du porte-outil Halter-Breite Holder width	Longueur du porte-outil Halter-Länge Holder length		Méthode de serrage Klemmsystem Clamping system	Forme de la plaquette Plattenform Insert shape	Géométrie du porte-outil Halterform Holder geometry	Angle de dépointe de la plaquette WSP-Freiwinkel Insert clearance angle	Direction de coupe Schneidrichtung Cut direction		Dimension de la plaquette (L) WSP Grösse (L) Insert size (L)
<b>A</b>	<b>12</b>	<b>K</b>	<b>-</b>	<b>S</b>	<b>C</b>	<b>L</b>	<b>C</b>	<b>R</b>	<b>-</b>	<b>06</b>

**Longueur  
Länge  
Length**  
 F = 80  
 H = 100  
 J = 110  
 K = 125  
 M = 150  
 Q = 180

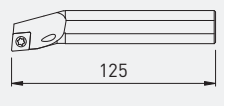

**Ø queue  
Schaft Ø  
Shank Ø**

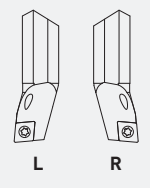
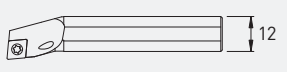

**L = 95°  
Q = 107.5°  
U = 93°**

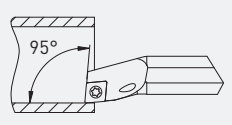

**A =** acier avec lubrification  
Stahl mit Kühlung  
Steel with coolant

**E =** carbure avec lubrification  
Hartmetall mit Kühlung  
Carbide with coolant

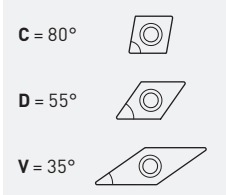

**S =** vis  
Schraube  
screw

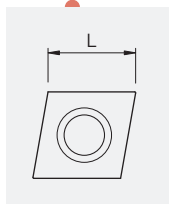
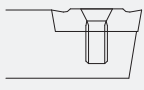

# ISO-LINE

## Codification des plaquettes ISO-Line

## ISO-Line Bezeichnungssystem für WSP

## ISO-Line designation system for inserts

Forme de la plaquette Plattenform Insert shape	Angle de dépointe de la plaquette WSP-Freiwinkel Insert clearance angle	Classe de tolérance Toleranz Klasse Tolerance class	Brise-copeau Spanbrecher Chip breaker		Dimension de la plaquette (L) WSP Größe (L) Insert size (L)	Épaisseur de la plaquette (E) WSP Dicke (E) Insert thickness (E)	Rayon de pointe de la plaquette WSP Eckenradius Insert corner radius		Exécution d'arête et direction de coupe Schneidkante Ausführung und Schneidrichtung Edge type and cutting direction		Géométrie de coupe Spanformgeometrie Cutting geometry														
<b>D</b>	<b>C</b>	<b>G</b>	<b>T</b>	<b>-</b>	<b>11</b>	<b>T3</b>	<b>04</b>	<b>-</b>	<b>FN</b>	<b>-</b>	<b>X8</b>														
		$G = \pm 0.025 \text{ mm}$  $M = \pm 0.05 \text{ mm}$ 	 			$R:$ 003 = 0.03 mm 005 = 0.05 mm 008 = 0.08 mm 01 = 0.1 mm 015 = 0.15 mm 02 = 0.2 mm 04 = 0.4 mm 08 = 0.8 mm 		    																	
	$C = 7^\circ$ 				<table border="1"> <thead> <tr> <th>L</th> <th>Ø d [mm]</th> </tr> </thead> <tbody> <tr> <td>CC...<b>06</b></td> <td></td> </tr> <tr> <td>DC...<b>07</b></td> <td>6.350</td> </tr> <tr> <td>VC... <b>11</b></td> <td></td> </tr> <tr> <td>VC... <b>13</b></td> <td>7.940</td> </tr> <tr> <td>CC...<b>09</b></td> <td></td> </tr> <tr> <td>DC... <b>11</b></td> <td>9.525</td> </tr> <tr> <td>VC... <b>16</b></td> <td></td> </tr> </tbody> </table>	L	Ø d [mm]	CC... <b>06</b>		DC... <b>07</b>	6.350	VC... <b>11</b>		VC... <b>13</b>	7.940	CC... <b>09</b>		DC... <b>11</b>	9.525	VC... <b>16</b>					
L	Ø d [mm]																								
CC... <b>06</b>																									
DC... <b>07</b>	6.350																								
VC... <b>11</b>																									
VC... <b>13</b>	7.940																								
CC... <b>09</b>																									
DC... <b>11</b>	9.525																								
VC... <b>16</b>																									



Géométries de coupe  
Spanformgeometrien  
Cutting geometries

**G**  
tolerance class

Plaquettes en métal dur rectifiées  
VHM geschliffene WSP  
Carbide ground inserts

**Finishing**

**FN-X8**

8°

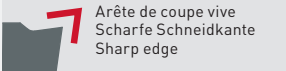

Arête de coupe vive  
Scharfe Schneidkante  
Sharp edge

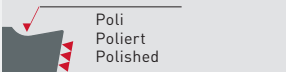

Poli  
Poliert  
Polished

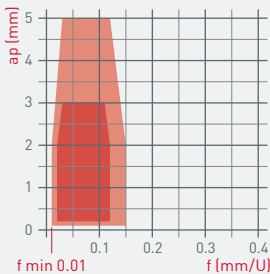

ap (mm)

f (mm/U)

f min 0.01

P	★★★★★
M	★★★★
N	★★★
S	★★★



CCGT DCGT VCGT



p. 7.19 p. 7.37 p. 7.54

**Semi-finishing**

**ENP-X8**

8°

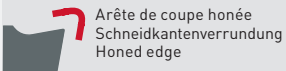

Arête de coupe honée  
Schneidkantenverrundung  
Honed edge

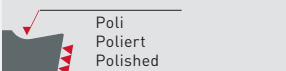

Poli  
Poliert  
Polished

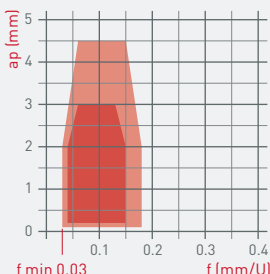

ap (mm)

f (mm/U)

f min 0.03

P	★★★★★
M	★★★
N	★★★
S	★★★



CCGT DCGT VCGT



p. 7.19 p. 7.37 p. 7.54

**Finishing**

**FN-X17**

17°

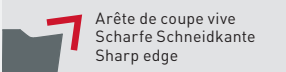

Arête de coupe vive  
Scharfe Schneidkante  
Sharp edge



Poli  
Poliert  
Polished

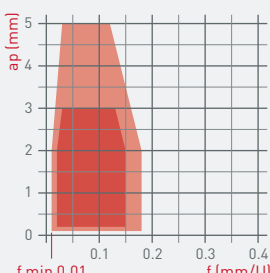

ap (mm)

f (mm/U)

f min 0.01

P	★★★
M	★★★★★
N	★★★★★
S	★★★★★



CCGT DCGT VCGT



p. 7.20 p. 7.38 p. 7.55

**Semi-finishing**

**ENP-X17**

17°

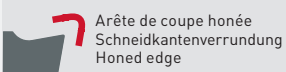

Arête de coupe honée  
Schneidkantenverrundung  
Honed edge

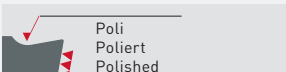

Poli  
Poliert  
Polished

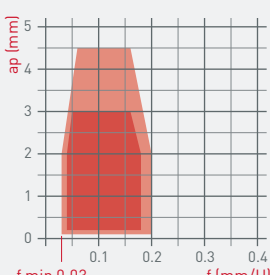

ap (mm)

f (mm/U)

f min 0.03

P	★★★
M	★★★★★
N	★★★
S	★★★★★

CCGT DCGT VCGT



p. 7.20 p. 7.38 p. 7.55

# ISO-LINE

Géométries de coupe  
Spanformgeometrien  
Cutting geometries

**G**  
tolerance class

Plaquettes en métal dur rectifiées  
VHM geschliffene WSP  
Carbide ground inserts

**FN-X25**

**Finishing**

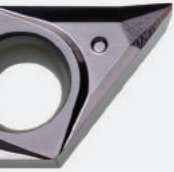

**25°**

Arête de coupe vive  
Scharfe Schneidkante  
Sharp edge

Poli  
Poliert  
Polished

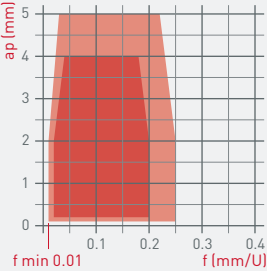

ap (mm)

f (mm/U)

f min 0.01

P	
M	★★★
N	★★★★★
S	★★★★★

CCGT DCGT VCGT



p. 7.21 p. 7.39 p. 7.56

**ENP-X25**

**Semi-finishing**



**25°**

Arête de coupe honée  
Schneidkantenverrundung  
Honed edge

Poli  
Poliert  
Polished

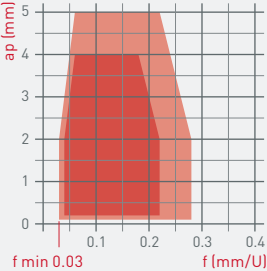

ap (mm)

f (mm/U)

f min 0.03

P	
M	★★★
N	★★★★★
S	★★★★★

CCGT DCGT VCGT



p. 7.21 p. 7.39 p. 7.56

**ENP-X20**

**Semi-finishing**

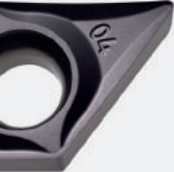

**20°**

Arête de coupe honée  
Schneidkantenverrundung  
Honed edge

Poli  
Poliert  
Polished

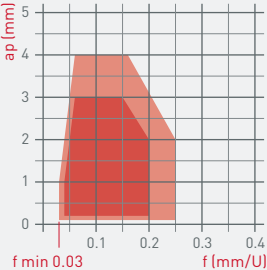

ap (mm)

f (mm/U)

f min 0.03

P	
M	★★★★★
N	★★★★★
S	★★★★★

CCGT DCGT VCGT



p. 7.22 p. 7.40 p. 7.57

Géométries de coupe  
Spanformgeometrien  
Cutting geometries



**M**  
tolerance class

Plaquettes en métal dur  
VHM-Wendepplatten  
Carbide inserts

**EN-XF3**

Semi-finishing

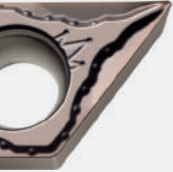
Finishing

12°

Arête de coupe honée  
Schneidkantenverrundung  
Honed edge

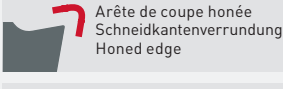
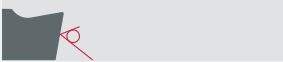
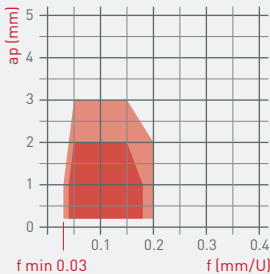

ap (mm)

f (mm/U)

f min 0.03

P	★★★★★
M	★★★★★
N	★★★
S	★★★

CCMT DCMT VCMT







p. 7.23 p. 7.41 p. 7.58

**EN-XF2**

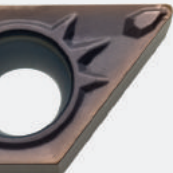
Semi-finishing

Finishing

6°

Arête de coupe honée  
Schneidkantenverrundung  
Honed edge

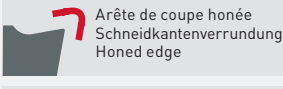
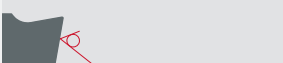
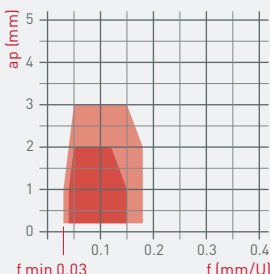

ap (mm)

f (mm/U)

f min 0.03

P	★★★★★
M	★★★
N	
S	★★★



CCMT DCMT VCMT

p. 7.23 p. 7.41 p. 7.58

**EN-MF2**

Semi-finishing

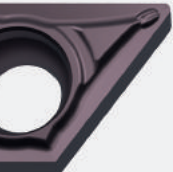
8°

Arête de coupe honée  
Schneidkantenverrundung  
Honed edge

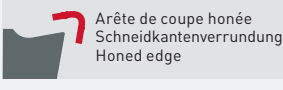
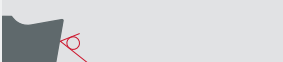
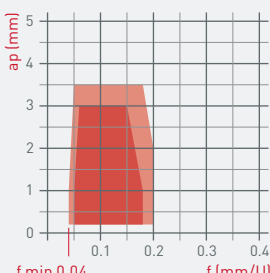

ap (mm)

f (mm/U)

f min 0.04

P	★★★★★
M	★★★★★
N	★★★
S	★★★

CCMT DCMT

p. 7.23 p. 7.41

# ISO-LINE

Géométries de coupe  
Spanformgeometrien  
Cutting geometries

**M**  
tolerance class

Plaquettes en métal dur  
VHM-Wendeplatten  
Carbide inserts

**EN-MF**

Semi-finishing

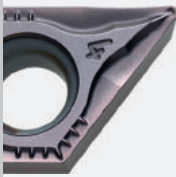

5°

Arête de coupe honée  
Schneidkantenverrundung  
Honed edge

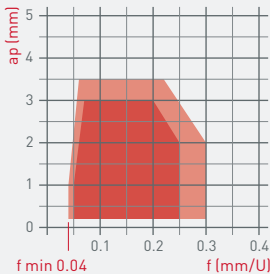

ap (mm)

f (mm/U)

f min 0.04

P	★★★★★
M	★★★
N	
S	

CCMT DCMT VCMT

p. 7.24 p. 7.42 p. 7.59

**EN-HF3**

Roughing

Semi-finishing

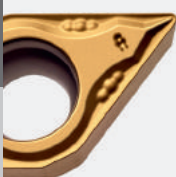

10°

Arête de coupe honée  
Schneidkantenverrundung  
Honed edge

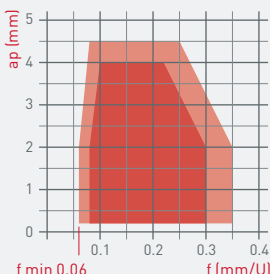

ap (mm)

f (mm/U)

f min 0.06

P	★★★★★
M	★★★★★
N	
S	★★★

CCMT DCMT

p. 7.24 p. 7.42

**EN-HF**

Roughing

Semi-finishing



12°

Arête de coupe honée  
Schneidkantenverrundung  
Honed edge

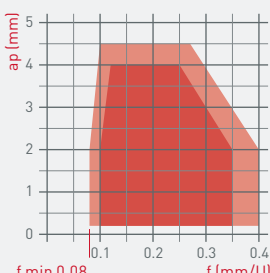

ap (mm)

f (mm/U)

f min 0.08

P	★★★★★
M	★★★★★
N	
S	

CCMT DCMT VCMT

p. 7.24 p. 7.42 p. 7.59



Géométries de coupe  
Spanformgeometrien  
Cutting geometries

**G**  
tolerance class

Plaquettes en métal dur rectifiées  
VHM geschliffene WSP  
Carbide ground inserts

**Super-finishing**

**FL/FR-X10**



**10°**



Arête de coupe vive  
Scharfe Schneidkante  
Sharp edge

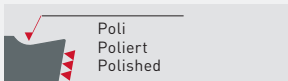

Poli  
Poliert  
Polished

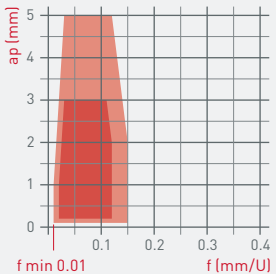

ap (mm)

f min 0.01

f (mm/U)

P	★★★★★
M	★★★★★
N	★★★★★
S	★★★★★

VC6T



p. 7.52

**Semi-finishing**

**ELP/ERP-X10**



**10°**

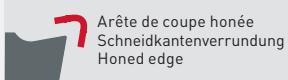

Arête de coupe honée  
Schneidkantenverrundung  
Honed edge

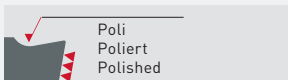

Poli  
Poliert  
Polished

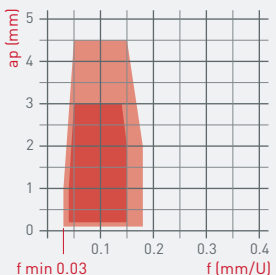

ap (mm)

f min 0.03

f (mm/U)

P	★★★★★
M	★★★★★
N	★★★★
S	★★★★

VC6T



p. 7.52

**Super-finishing**

**FN-K18**



**18°**



Arête de coupe vive  
Scharfe Schneidkante  
Sharp edge



Poli  
Poliert  
Polished

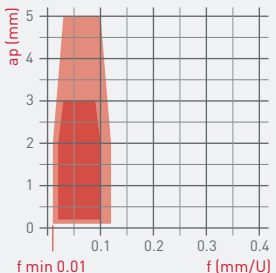

ap (mm)

f min 0.01

f (mm/U)

P	★★★★★
M	★★★★★
N	★★★★★
S	★★★★★

VC6T



p. 7.53

**Finishing**

**FN-0**

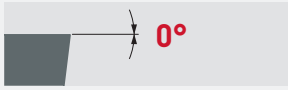

**0°**



Arête de coupe vive  
Scharfe Schneidkante  
Sharp edge

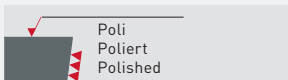

Poli  
Poliert  
Polished

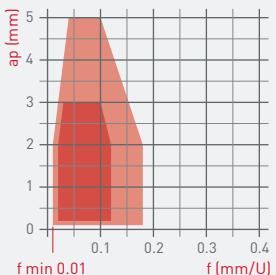

ap (mm)

f min 0.01

f (mm/U)

P	★★★
M	
N	★★★
S	

VC6W



p. 7.53

**Finishing**

### FN-X8 CERMET



8°

Arête de coupe vive  
Scharfe Schneidkante  
Sharp edge

Poli  
Poliert  
Polished

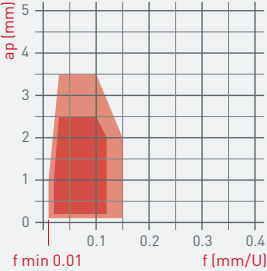

ap (mm)

f (mm/U)

f min 0.01

P	★★★★★
M	★★★
N	
S	

CCGT DCGT VCGT

p. 7.25 p. 7.43 p. 7.60

**Semi-finishing**

### ENP-KX CERMET



8°

Arête de coupe honée  
Schneidkantenverrundung  
Honed edge

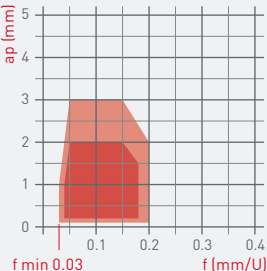

ap (mm)

f (mm/U)

f min 0.03

P	★★★★★
M	★★★
N	
S	

CCGT DCGT

p. 7.25 p. 7.43

**Semi-finishing**

### EN-KM CERMET

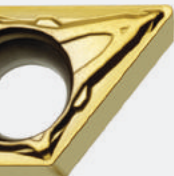

8°

Arête de coupe honée  
Schneidkantenverrundung  
Honed edge

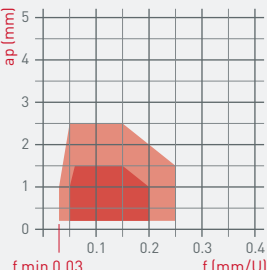

ap (mm)

f (mm/U)

f min 0.03

P	★★★★★
M	★★★
N	
S	

CCMT DCMT

p. 7.26 p. 7.44

Nuances

Sorten

Grades

Nuances Sorten Grades	Domaine d'application Anwendungsbereich Application area	Finishing / light machining	Semi-finishing / medium cut	Roughing / heavy machining	Géométries de coupe disponibles Verfügbare Spanformgeometrien Available cutting geometries	Résistance à l'usure Verschleißfestigkeit Wear resistance	Ténacité, résistance à la rupture Zähigkeit, Bruchwiderstand Toughness, crack resistance	Résistance à la température Bearbeitungswarmfestigkeit Machining heat resistance	Revêtement et couleur Beschichtung und Farbe Coating and colour	Recommandations spéciales Sonder-Empfehlungen Special recommendations
<b>Carbide + PVD</b>										
TiAlN	★★★★★ ★★★★★ ★★★★★ ★★★★	■	■	■	FN/ENP-X8 FN/ENP-X17 FN/ENP-X25 L/R-X10	■■■■■□	■■■■■□	■■■■■□	PVD	
HTA	★★★★★ ★★★★★ ★★★★★ ★★★★	■			FN-X8 FN-X17 FN-X25 L/R-X10 FN-K18 FN-0	■■■■■	■■■■■□	■■■■■□	PVD	
TiN	★★★★ ★★★★ ★★★★★	■	■	■	FN/ENP-X8 FN/ENP-X17 FN/ENP-X25 L/R-X10	■■■■□□	■■■■■□	■■■■□□	PVD	High resistance to edge build up
HTiN	★★★★ ★★★★ ★★★★★	■			FN-K18 FN-0	■■■■■□	■■■■■□	■■■■□□	PVD	High resistance to edge build up
TAC	★★★★★ ★★★★★ ★★★★★ ★★★★	■	■	■	EN-XF3 EN-XF2 EN-MF2 EN-HF	■■■■■□	■■■■■□	■■■■■□	PVD	
HTAC	★★★★★ ★★★★★ ★★★★★ ★★★★	■	■		EN-XF3 EN-XF2 EN-MF2	■■■■■	■■■■■□	■■■■■□	PVD	
TiX	★★★★★ ★★★★★ ★★★			■	EN-HF3	■■■■□□	■■■■■□	■■■■□□	PVD	Easy wear out control with TiN top layer
HTiX	★★★★★ ★★★★★ ★★★★★ ★★★	■	■		ENP-X20 EN-HF3	■■■■■□	■■■■■□	■■■■□□	PVD	Easy wear out control with TiN top layer
Tmax	★★★★★ ★★★★★ ★★★★★ ★★★★	■	■		EN-MF EN-HF	■■■■■□	■■■■■□	■■■■■□	PVD	
ZTA	★★★★★ ★★★★★ ★★★★★	■	■		ENP-X20	■■■■■□	■■■■■□	■■■■■□	PVD	perfect for titanium alloys & superalloys
TiAlX	★★★★★ ★★★★★ ★★★★★	■	■		X8 R-X10 X17 X25	■■■■■□	■■■■■□	■■■■■□	PVD	perfect for titanium alloys & superalloys
HTAX	★★★★★ ★★★★★ ★★★★★	■			X8 R-X10 X17 X25	■■■■■	■■■■■□	■■■■■□	PVD	perfect for titanium alloys & superalloys

# ISO-LINE

Nuances

Sorten

Grades

Nuances Sorten Grades	Domaine d'application Anwendungsbereich Application area	Finishing / light machining	Semi-finishing / medium cut	Roughing / heavy machining	Géométries de coupe disponibles Verfügbare Spanformgeometrien Available cutting geometries	Résistance à l'usure Verschleißfestigkeit Wear resistance	Ténacité, résistance à la rupture Zähigkeit, Bruchwiderstand Toughness, crack resistance	Résistance à la température Bearbeitungswarmfestigkeit Machining heat resistance	Revêtement et couleur Beschichtung und Farbe Coating and colour	Recommandations spéciales Sonder-Empfehlungen Special recommendations
<b>Carbide + CVD</b>										
Ti4	★★★★★ ★★★		■	■	EN-MF EN-HF3 EN-HF	■■■■■□	■■■■■□	■■■■■	CVD	
Ti5	★★★★★ ★★★		■	■	EN-MF2 EN-HF	■■■■■□	■■■■■□	■■■■■	CVD	Easy wear out control with TiN top layer
HTi5	★★★★★ ★★★		■	■	EN-XF2 EN-MF2 EN-HF	■■■■■	■■■■□□	■■■■■	CVD	Easy wear out control with TiN top layer
Ti6	★★★ ★★★★★ ★★★★★		■	■	EN-HF3	■■■■■□	■■■■■□	■■■■■	CVD	
<b>Carbide uncoated</b>										
K10	★★★ ★★★		■		FN-X8 FN-X17 FN-X25 ELP-X10/ERP-X10 FN-K18 FN-0	■■■■□□	■■■■□□	■■■■□□	uncoated	
K20	★★ ★★		■		FN/ENP-X8 FN/ENP-X17 FN/ENP-X25 ELP-X10/ERP-X10	■■■■□□	■■■■□□	■■■■□□	uncoated	
<b>CERMET</b>										
CTA	★★★★★ ★★★		■		FN-X8	■■■■■□	■■■■■□	■■■■■	CERMET +PVD	
CT7	★★★★★ ★★★		■	■	ENP-KX EN-KM	■■■■■□	■■■■■□	■■■■■	CERMET + PVD	Easy wear out control with TiN top layer
HCT7	★★★★★ ★★★		■	■	ENP-KX EN-KM	■■■■■	■■■■□□	■■■■■	CERMET + PVD	Easy wear out control with TiN top layer
CN6	★★★★		■		FN-X8 ENP-KX EN-KM	■■■■□□	■■■■■□	■■■■■□	CERMET uncoated	

Porte-outils

Halter

Holders

80°

SCM

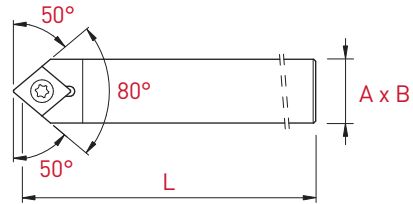

SCM

Plaquettes WSP Inserts	A x B	L	Art. N°
CC...-0602..	8 x 8	115	SCMCN-0808X-06
	10 x 10	115	SCMCN-1010X-06
	12 x 12	130	SCMCN-1212X-06
	12 x 12	90	SCMCN-1212G-06
	12.7 x 12.7	130	SCMCN-12.7X-06
	16 x 16	130	SCMCN-1616X-06
	16 x 16	75	SCMCN-1616F-06
CC...-09T3..	12 x 12	130	SCMCN-1212X-09
	12 x 12	90	SCMCN-1212G-09
	12.7 x 12.7	130	SCMCN-12.7X-09
	16 x 16	130	SCMCN-1616X-09
	16 x 16	75	SCMCN-1616F-09
	20 x 20	120	SCMCN-2020X-09



SCA

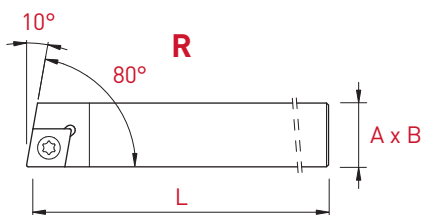

Plaquettes WSP Inserts	A x B	L	Art. N°	Art. N°
CC..-0602..	8 x 8	115	SCACL-0808X-06	SCACR-0808X-06
	10 x 10	115	SCACL-1010X-06	SCACR-1010X-06
	12 x 12	130	SCACL-1212X-06	SCACR-1212X-06
	12 x 12	90	SCACL-1212G-06	SCACR-1212G-06
	12.7 x 12.7	130	SCACL-12.7X-06	SCACR-12.7X-06
	16 x 16	130	SCACL-1616X-06	SCACR-1616X-06
	16 x 16	75	SCACL-1616F-06	SCACR-1616F-06
CC..-09T3..	12 x 12	130	SCACL-1212X-09	SCACR-1212X-09
	12 x 12	90	SCACL-1212G-09	SCACR-1212G-09
	12.7 x 12.7	130	SCACL-12.7X-09	SCACR-12.7X-09
	16 x 16	130	SCACL-1616X-09	SCACR-1616X-09
	16 x 16	75	SCACL-1616F-09	SCACR-1616F-09
	20 x 20	120	SCACL-2020X-09	SCACR-2020X-09

Porte-outils

Halter

Holders

80°

SCL



SCL

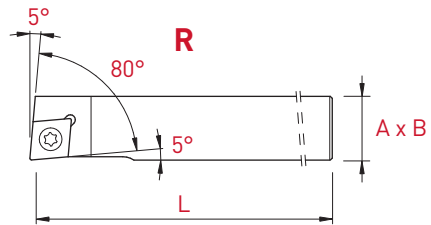

Plaquettes WSP Inserts	A x B	L	Art. N°	Art. N°
CC..-0602..	8 x 8	115	SCLCL-0808X-06	SCLCR-0808X-06
	10 x 10	115	SCLCL-1010X-06	SCLCR-1010X-06
	12 x 12	130	SCLCL-1212X-06	SCLCR-1212X-06
	12 x 12	90	SCLCL-1212G-06	SCLCR-1212G-06
	12.7 x 12.7	130	SCLCL-12.7X-06	SCLCR-12.7X-06
	16 x 16	130	SCLCL-1616X-06	SCLCR-1616X-06
	16 x 16	75	SCLCL-1616F-06	SCLCR-1616F-06
CC..-09T3..	12 x 12	130	SCLCL-1212X-09	SCLCR-1212X-09
	12 x 12	90	SCLCL-1212G-09	SCLCR-1212G-09
	12.7 x 12.7	130	SCLCL-12.7X-09	SCLCR-12.7X-09
	16 x 16	130	SCLCL-1616X-09	SCLCR-1616X-09
	16 x 16	75	SCLCL-1616F-09	SCLCR-1616F-09
	20 x 20	120	SCLCL-2020X-09	SCLCR-2020X-09

# ISO-LINE

Porte-outils avec arrosage intégré  
 Halter mit integrierter Kühlmittelzufuhr  
 Holders with integrated coolant supply

80°

SCL-JET

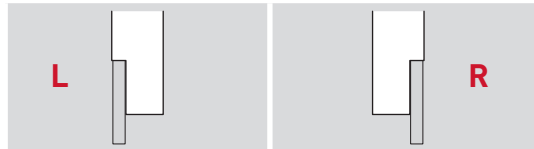
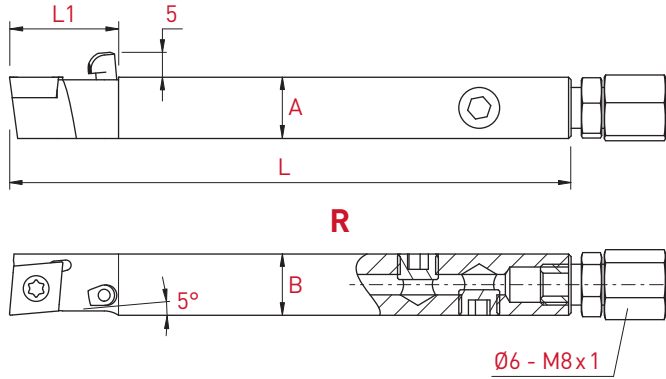

Plaquettes WSP Inserts	A x B	L	L1	Art. N°	Art. N°
CC...-0602..	10 x 10	110	21	SCLCL-1010J-06-JET	SCLCR-1010J-06-JET
	12 x 12	110	21	SCLCL-1212J-06-JET	SCLCR-1212J-06-JET
	12.7 x 12.7	110	21	SCLCL-12.7J-06-JET	SCLCR-12.7J-06-JET
	16 x 16	110	21	SCLCL-1616J-06-JET	SCLCR-1616J-06-JET
CC...-09T3..	12 x 12	110	21	SCLCL-1212J-09-JET	SCLCR-1212J-09-JET
	12.7 x 12.7	110	21	SCLCL-12.7J-09-JET	SCLCR-12.7J-09-JET
	16 x 16	110	21	SCLCL-1616J-09-JET	SCLCR-1616J-09-JET
	20 x 20	110	21	SCLCL-2020J-09-JET	SCLCR-2020J-09-JET



Porte-outils intérieurs amincis

Verjüngte Innenhalter

Thinned internal holders

80°

A-SCLCR/L

new

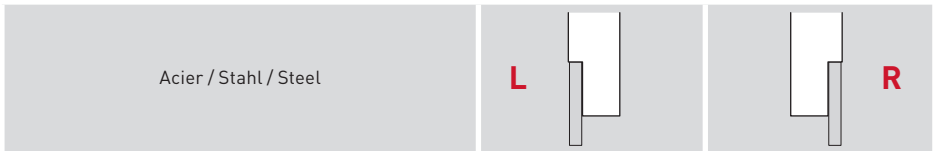
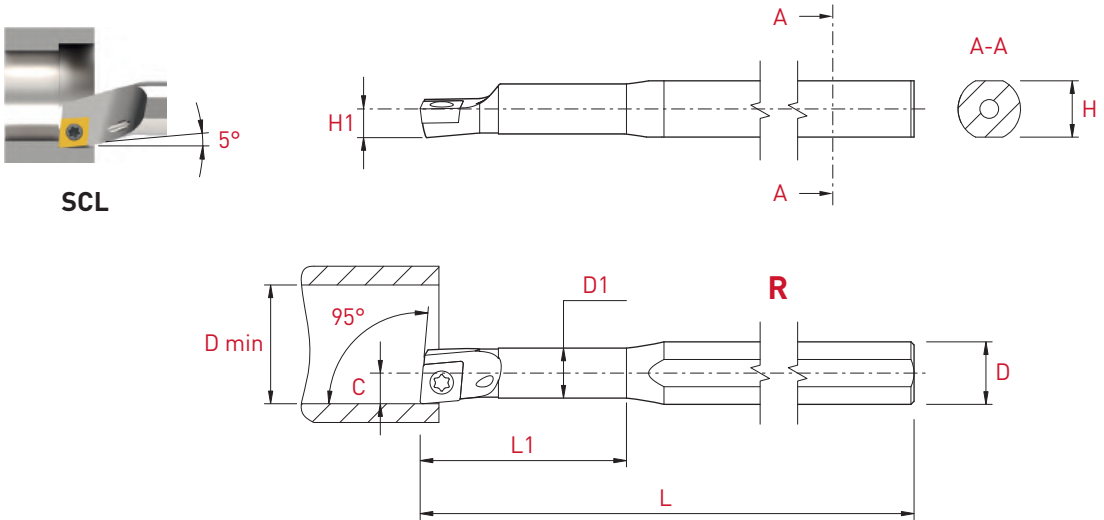

Plaquettes WSP Inserts	Acier / Stahl / Steel								Art. N°	Art. N°
	D	D min	D1	C	H1	L	L1	H		
CC...-0602..	8	8	6	4	4	100	25	7	A0608H-SCLCL-06	A0608H-SCLCR-06
	10	12	8	6	5	110	32	9	A0810J-SCLCL-06	A0810J-SCLCR-06
	12	14	10	7	6	125	38	11	A1012K-SCLCL-06	A1012K-SCLCR-06

Pour barres d'alésage For boring bar Für Borstange	Pièces de rechange Ersatzteile Spare parts	
	Art. N°	Art. N°
A0608H_ / A0810J_	V-M2.5X4.8-T8	C-T8
A1012K_	V-M2.5X5.8-T8	

**new**

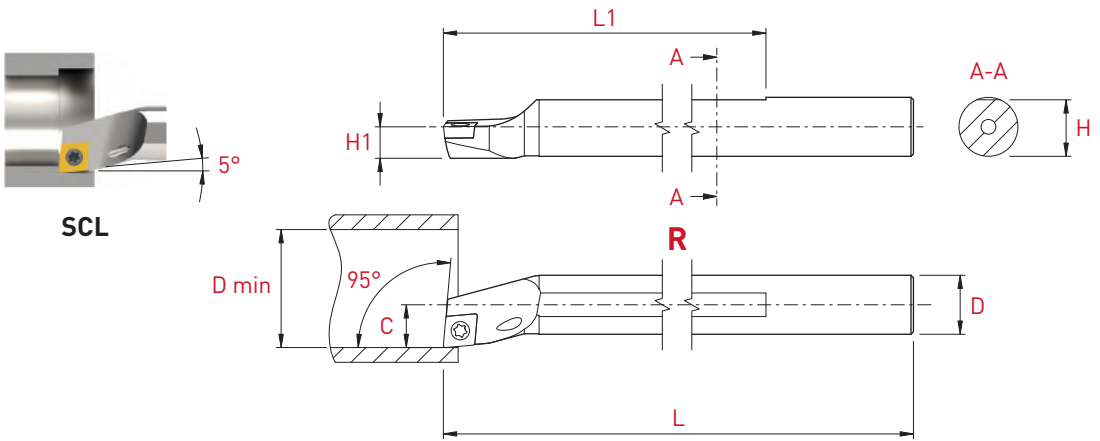

Acier / Stahl / Steel								L	R
-----------------------	--	--	--	--	--	--	--	---	---

Plaquettes WSP Inserts	D	D min	C	H1	L	L1	H	Art. N°	
								L	R
CC...-0602	8	11	5	4	80	74	7.5	A08F-SCLCL-06	A08F-SCLCR-06
	10	13	7	5	100	85	9.5	A10H-SCLCL-06	A10H-SCLCR-06
	12	16	9	6	125	95	11.5	A12K-SCLCL-06	A12K-SCLCR-06
CC...-09T3	16	20	11	8	150	117	15.5	A16M-SCLCL-09	A16M-SCLCR-09

Carbure de tungstène / Hartmetall / Solid carbide								Art. N°	
D	D min	C	H1	L	L1	H	Art. N°		

CC...-0602	8	9	5	4	125	-	7.5	E08K-SCLCL 06	E08K-SCLCR 06
	10	11	6	5	125	-	9.5	E10K-SCLCL-06	E10K-SCLCR 06
	12	13	8	6	150	-	11.5	E12M-SCLCL 06	E12M-SCLCR 06

Pour barres d'alésage For boring bar Für Borstange	Pièces de rechange Ersatzteile Spare parts	
	Art. N°	Art. N°
	A08F_ / E08K_	V-M2.5X4.8-T8
A10H_ / E10H_	V-M2.5X5.8-T8	C-T8
A16M_	V-M3.5X7.2-T15-ISO	C-T15

Plaquettes en métal dur

VHM-Wendeplatten

Solid carbide inserts

80°

CCGT-X8



CCGT  
FN-X8

R	Art. N°	PVD			non revêtu unbeschichtet uncoated	
		TiAlN	HTA	TiN	K10	K20
		P M N S	P M N S	P M N		
0.05	CCGT-0602005-FN-X8	■	■	■	■	■
0.1	CCGT-060201-FN-X8	■	■	■	■	■
0.2	CCGT-060202-FN-X8	■	■	■	■	■
0.4	CCGT-060204-FN-X8	■	■	■	■	■
0.05	CCGT-09T3005-FN-X8	■	■	■	■	■
0.1	CCGT-09T301-FN-X8	■	■	■	■	■
0.2	CCGT-09T302-FN-X8	■	■	■	■	■
0.4	CCGT-09T304-FN-X8	■	■	■	■	■



CCGT  
ENP-X8

R	Art. N°	PVD		non revêtu unbeschichtet uncoated
		TiAlN	TiN	K20
		P M N S	P M N	N
0.05	CCGT-0602005-ENP-X8	■	■	■
0.1	CCGT-060201-ENP-X8	■	■	■
0.2	CCGT-060202-ENP-X8	■	■	■
0.4	CCGT-060204-ENP-X8	■	■	■
0.05	CCGT-09T3005-ENP-X8	■	■	■
0.1	CCGT-09T301-ENP-X8	■	■	■
0.2	CCGT-09T302-ENP-X8	■	■	■
0.4	CCGT-09T304-ENP-X8	■	■	■





CCGT  
FN-X17

R	Art. N°	PVD			non revêtu unbeschichtet uncoated	
		TiAlN	HTA	TiN	K10	K20
		P M N S	P M N S	P M N	<input type="checkbox"/>	<input type="checkbox"/>
0.05	CCGT-0602005-FN-X17	<input checked="" type="checkbox"/>	<input checked="" type="checkbox"/>	<input checked="" type="checkbox"/>	<input checked="" type="checkbox"/>	<input checked="" type="checkbox"/>
0.1	CCGT-060201-FN-X17	<input checked="" type="checkbox"/>	<input checked="" type="checkbox"/>	<input checked="" type="checkbox"/>	<input checked="" type="checkbox"/>	<input checked="" type="checkbox"/>
0.2	CCGT-060202-FN-X17	<input checked="" type="checkbox"/>	<input checked="" type="checkbox"/>	<input checked="" type="checkbox"/>	<input checked="" type="checkbox"/>	<input checked="" type="checkbox"/>
0.4	CCGT-060204-FN-X17	<input checked="" type="checkbox"/>	<input checked="" type="checkbox"/>	<input checked="" type="checkbox"/>	<input checked="" type="checkbox"/>	<input checked="" type="checkbox"/>
0.05	CCGT-09T3005-FN-X17	<input checked="" type="checkbox"/>	<input checked="" type="checkbox"/>	<input checked="" type="checkbox"/>	<input checked="" type="checkbox"/>	<input checked="" type="checkbox"/>
0.1	CCGT-09T301-FN-X17	<input checked="" type="checkbox"/>	<input checked="" type="checkbox"/>	<input checked="" type="checkbox"/>	<input checked="" type="checkbox"/>	<input checked="" type="checkbox"/>
0.2	CCGT-09T302-FN-X17	<input checked="" type="checkbox"/>	<input checked="" type="checkbox"/>	<input checked="" type="checkbox"/>	<input checked="" type="checkbox"/>	<input checked="" type="checkbox"/>
0.4	CCGT-09T304-FN-X17	<input checked="" type="checkbox"/>	<input checked="" type="checkbox"/>	<input checked="" type="checkbox"/>	<input checked="" type="checkbox"/>	<input checked="" type="checkbox"/>
0.8	CCGT-09T308-FN-X17	<input checked="" type="checkbox"/>	<input checked="" type="checkbox"/>	<input checked="" type="checkbox"/>	<input checked="" type="checkbox"/>	<input checked="" type="checkbox"/>

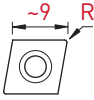

CCGT  
ENP-X17

R	Art. N°	PVD		non revêtu unbeschichtet uncoated
		TiAlN	TiN	K20
		P M N S	P M N	<input type="checkbox"/> <input type="checkbox"/> <input checked="" type="checkbox"/>
0.05	CCGT-0602005-ENP-X17	<input checked="" type="checkbox"/>	<input checked="" type="checkbox"/>	<input checked="" type="checkbox"/>
0.1	CCGT-060201-ENP-X17	<input checked="" type="checkbox"/>	<input checked="" type="checkbox"/>	<input checked="" type="checkbox"/>
0.2	CCGT-060202-ENP-X17	<input checked="" type="checkbox"/>	<input checked="" type="checkbox"/>	<input checked="" type="checkbox"/>
0.4	CCGT-060204-ENP-X17	<input checked="" type="checkbox"/>	<input checked="" type="checkbox"/>	<input checked="" type="checkbox"/>
0.05	CCGT-09T3005-ENP-X17	<input checked="" type="checkbox"/>	<input checked="" type="checkbox"/>	<input checked="" type="checkbox"/>
0.1	CCGT-09T301-ENP-X17	<input checked="" type="checkbox"/>	<input checked="" type="checkbox"/>	<input checked="" type="checkbox"/>
0.2	CCGT-09T302-ENP-X17	<input checked="" type="checkbox"/>	<input checked="" type="checkbox"/>	<input checked="" type="checkbox"/>
0.4	CCGT-09T304-ENP-X17	<input checked="" type="checkbox"/>	<input checked="" type="checkbox"/>	<input checked="" type="checkbox"/>
0.8	CCGT-09T308-ENP-X17	<input checked="" type="checkbox"/>	<input checked="" type="checkbox"/>	<input checked="" type="checkbox"/>

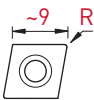



Plaquettes en métal dur

VHM-Wendeplatten

Solid carbide inserts

80°

CCGT-X20



**CCGT  
ENP-X20**

PVD	
ZTA	HTiX
<input type="checkbox"/>	<input type="checkbox"/>
<input checked="" type="checkbox"/> M	<input checked="" type="checkbox"/> M
<input checked="" type="checkbox"/> N	<input checked="" type="checkbox"/> N
<input checked="" type="checkbox"/> S	<input checked="" type="checkbox"/> S

R	H	Art. N°	ZTA	HTiX
~6 R	0.1	CCGT-060201-ENP-X20	■	
	0.2	CCGT-060202-ENP-X20	■	■
	0.4	CCGT-060204-ENP-X20	■	■
~9 R	0.1	CCGT-09T301-ENP-X20	■	
	0.2	CCGT-09T302-ENP-X20	■	■
	0.4	CCGT-09T304-ENP-X20	■	■
	0.8	CCGT-09T308-ENP-X20	■	■

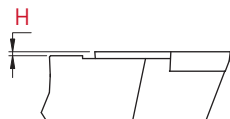
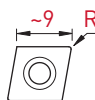

Plaquettes en métal dur

VHM-Wendepplatten

Solid carbide inserts

80°

CCMT-XF3

CCMT-XF2

CCMT-MF2

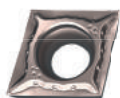

CCMT  
EN-XF3

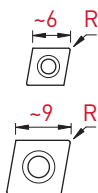

R	Art. N°	PVD	
		TAC	HTAC
0.2	CCMT-060202-EN-XF3	<input checked="" type="checkbox"/>	<input checked="" type="checkbox"/>
0.4	CCMT-060204-EN-XF3	<input checked="" type="checkbox"/>	<input checked="" type="checkbox"/>
0.2	CCMT-09T302-EN-XF3	<input checked="" type="checkbox"/>	<input checked="" type="checkbox"/>
0.4	CCMT-09T304-EN-XF3	<input checked="" type="checkbox"/>	<input checked="" type="checkbox"/>

PVD	
<input checked="" type="checkbox"/> P	<input checked="" type="checkbox"/> P
<input checked="" type="checkbox"/> M	<input checked="" type="checkbox"/> M
<input checked="" type="checkbox"/> N	<input checked="" type="checkbox"/> N
<input checked="" type="checkbox"/> S	<input checked="" type="checkbox"/> S
<input checked="" type="checkbox"/> TAC	<input checked="" type="checkbox"/> HTAC



CCMT  
EN-XF2

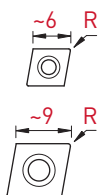

R	Art. N°	PVD		CVD
		TAC	HTAC	HTi5
0.2	CCMT-060202-EN-XF2	<input checked="" type="checkbox"/>	<input checked="" type="checkbox"/>	<input checked="" type="checkbox"/>
0.4	CCMT-060204-EN-XF2	<input checked="" type="checkbox"/>	<input checked="" type="checkbox"/>	<input checked="" type="checkbox"/>
0.2	CCMT-09T302-EN-XF2	<input checked="" type="checkbox"/>	<input checked="" type="checkbox"/>	<input checked="" type="checkbox"/>
0.4	CCMT-09T304-EN-XF2	<input checked="" type="checkbox"/>	<input checked="" type="checkbox"/>	<input checked="" type="checkbox"/>

PVD		CVD
<input checked="" type="checkbox"/> P	<input checked="" type="checkbox"/> P	<input checked="" type="checkbox"/> P
<input checked="" type="checkbox"/> M	<input checked="" type="checkbox"/> M	<input checked="" type="checkbox"/> M
<input checked="" type="checkbox"/> N	<input checked="" type="checkbox"/> N	<input type="checkbox"/>
<input checked="" type="checkbox"/> S	<input checked="" type="checkbox"/> S	<input type="checkbox"/>
<input checked="" type="checkbox"/> TAC	<input checked="" type="checkbox"/> HTAC	<input type="checkbox"/> HTi5

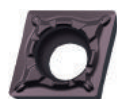

CCMT  
EN-MF2

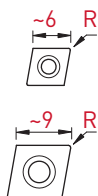

R	Art. N°	PVD		CVD	
		TAC	HTAC	Ti5	HTi5
0.2	CCMT-060202-EN-MF2	<input checked="" type="checkbox"/>	<input checked="" type="checkbox"/>	<input checked="" type="checkbox"/>	<input checked="" type="checkbox"/>
0.4	CCMT-060204-EN-MF2	<input checked="" type="checkbox"/>	<input checked="" type="checkbox"/>	<input checked="" type="checkbox"/>	<input checked="" type="checkbox"/>
0.2	CCMT-09T302-EN-MF2	<input checked="" type="checkbox"/>	<input checked="" type="checkbox"/>	<input checked="" type="checkbox"/>	<input checked="" type="checkbox"/>
0.4	CCMT-09T304-EN-MF2	<input checked="" type="checkbox"/>	<input checked="" type="checkbox"/>	<input checked="" type="checkbox"/>	<input checked="" type="checkbox"/>
0.8	CCMT-09T308-EN-MF2	<input checked="" type="checkbox"/>	<input checked="" type="checkbox"/>	<input checked="" type="checkbox"/>	<input checked="" type="checkbox"/>

PVD		CVD	
<input checked="" type="checkbox"/> P	<input checked="" type="checkbox"/> P	<input checked="" type="checkbox"/> P	<input checked="" type="checkbox"/> P
<input checked="" type="checkbox"/> M	<input checked="" type="checkbox"/> M	<input checked="" type="checkbox"/> M	<input checked="" type="checkbox"/> M
<input checked="" type="checkbox"/> N	<input checked="" type="checkbox"/> N	<input type="checkbox"/>	<input type="checkbox"/>
<input checked="" type="checkbox"/> S	<input checked="" type="checkbox"/> S	<input type="checkbox"/>	<input type="checkbox"/>
<input checked="" type="checkbox"/> TAC	<input checked="" type="checkbox"/> HTAC	<input type="checkbox"/> Ti5	<input type="checkbox"/> HTi5

Plaquettes en métal dur  
VHM-Wendeplatten  
Solid carbide inserts

80°

CCMT-MF  
CCMT-HF3  
CCMT-HF



**CCMT  
EN-MF**

R	Art. N°	PVD		CVD	
		Tmax	Ti4	Ti4	Ti4
0.2	CCMT-060202-EN-MF	■	■	■	■
0.4	CCMT-060204-EN-MF	■	■	■	■
0.2	CCMT-09T302-EN-MF	■	■	■	■
0.4	CCMT-09T304-EN-MF	■	■	■	■

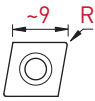

**CCMT  
EN-HF3**

R	Art. N°	PVD		CVD	
		TiX	HTiX	Ti6	Ti6
0.2	CCMT-060202-EN-HF3	■	■	■	■
0.4	CCMT-060204-EN-HF3	■	■	■	■
0.2	CCMT-09T302-EN-HF3	■	■	■	■
0.4	CCMT-09T304-EN-HF3	■	■	■	■
0.8	CCMT-09T308-EN-HF3	■	■	■	■

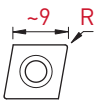

**CCMT  
EN-HF**

R	Art. N°	PVD		CVD		
		Tmax	TAC	Ti4	Ti5	HTi5
0.2	CCMT-060202-EN-HF	■	■	■	■	■
0.4	CCMT-060204-EN-HF	■	■	■	■	■
0.8	CCMT-060208-EN-HF	■	■	■	■	■
0.2	CCMT-09T302-EN-HF	■	■	■	■	■
0.4	CCMT-09T304-EN-HF	■	■	■	■	■
0.8	CCMT-09T308-EN-HF	■	■	■	■	■

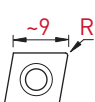



Plaquettes CERMET  
 CERMET-Wendeplatten  
 CERMET inserts

80°

CCGT-X8  
 CCGT-KX

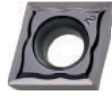

CCGT  
 FN-X8

		CERMET	
		PVD	non revêtu unbeschichtet uncoated
		<input checked="" type="checkbox"/> P <input checked="" type="checkbox"/> M <input type="checkbox"/> <input type="checkbox"/>	<input checked="" type="checkbox"/> P <input type="checkbox"/> <input type="checkbox"/> <input type="checkbox"/>
R	Art. N°	CTA	CN6
0.05	CCGT-0602005-FN-X8	<input checked="" type="checkbox"/>	<input checked="" type="checkbox"/>
0.1	CCGT-060201-FN-X8	<input checked="" type="checkbox"/>	<input checked="" type="checkbox"/>
0.2	CCGT-060202-FN-X8	<input checked="" type="checkbox"/>	<input checked="" type="checkbox"/>
0.05	CCGT-09T3005-FN-X8	<input checked="" type="checkbox"/>	<input checked="" type="checkbox"/>
0.1	CCGT-09T301-FN-X8	<input checked="" type="checkbox"/>	<input checked="" type="checkbox"/>
0.2	CCGT-09T302-FN-X8	<input checked="" type="checkbox"/>	<input checked="" type="checkbox"/>
0.4	CCGT-09T304-FN-X8	<input checked="" type="checkbox"/>	<input checked="" type="checkbox"/>



CCGT  
 ENP-KX

		CERMET		
		PVD		non revêtu unbeschichtet uncoated
		<input checked="" type="checkbox"/> P <input checked="" type="checkbox"/> M <input type="checkbox"/> <input type="checkbox"/>	<input checked="" type="checkbox"/> P <input checked="" type="checkbox"/> M <input type="checkbox"/> <input type="checkbox"/>	<input checked="" type="checkbox"/> P <input type="checkbox"/> <input type="checkbox"/> <input type="checkbox"/>
R	Art. N°	CT7	HCT7	CN6
0.1	CCGT-060201-ENP-KX	<input checked="" type="checkbox"/>	<input checked="" type="checkbox"/>	<input checked="" type="checkbox"/>
0.2	CCGT-060202-ENP-KX	<input checked="" type="checkbox"/>	<input checked="" type="checkbox"/>	<input checked="" type="checkbox"/>
0.4	CCGT-060204-ENP-KX	<input checked="" type="checkbox"/>	<input checked="" type="checkbox"/>	<input checked="" type="checkbox"/>
0.1	CCGT-09T301-ENP-KX	<input checked="" type="checkbox"/>	<input checked="" type="checkbox"/>	<input checked="" type="checkbox"/>
0.2	CCGT-09T302-ENP-KX	<input checked="" type="checkbox"/>	<input checked="" type="checkbox"/>	<input checked="" type="checkbox"/>
0.4	CCGT-09T304-ENP-KX	<input checked="" type="checkbox"/>	<input checked="" type="checkbox"/>	<input checked="" type="checkbox"/>





CCMT  
 EN-KM

		CERMET		
		PVD		non revêtu unbeschichtet uncoated
		P	P	P
		M	M	
		CT7	HCT7	CN6
R	Art. N°			
0.2	CCMT-060202-EN-KM	■	■	■
0.4	CCMT-060204-EN-KM	■	■	■
0.2	CCMT-09T302-EN-KM	■	■	■
0.4	CCMT-09T304-EN-KM	■	■	■
0.8	CCMT-09T308-EN-KM	■	■	■

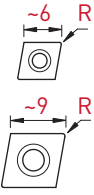

Porte-outils

Halter

Holders

55°

SDN



SDN

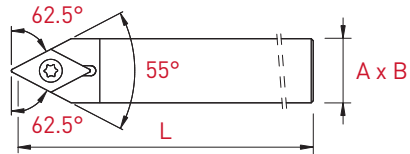

Plaquettes WSP Inserts	A x B	L	Art. N°
DC...-0702..	8 x 8	115	<b>SDNCN-0808X-07</b>
	10 x 10	115	<b>SDNCN-1010X-07</b>
	12 x 12	130	<b>SDNCN-1212X-07</b>
	12 x 12	90	<b>SDNCN-1212G-07</b>
	12.7 x 12.7	130	<b>SDNCN-12.7X-07</b>
	16 x 16	130	<b>SDNCN-1616X-07</b>
	16 x 16	75	<b>SDNCN-1616F-07</b>
DC...-11T3..	12 x 12	130	<b>SDNCN-1212X-11</b>
	12 x 12	90	<b>SDNCN-1212G-11</b>
	12.7 x 12.7	130	<b>SDNCN-12.7X-11</b>
	16 x 16	130	<b>SDNCN-1616X-11</b>
	16 x 16	75	<b>SDNCN-1616F-11</b>
	20 x 20	120	<b>SDNCN-2020X-11</b>



SDA

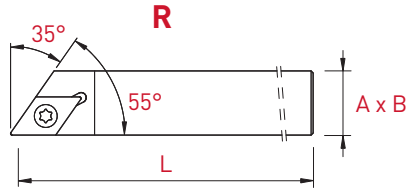

Plaquettes WSP Inserts	A x B	L	Art. N°	Art. N°
DC..-0702..	8 x 8	115	SDACL-0808X-07	SDACR-0808X-07
	10 x 10	115	SDACL-1010X-07	SDACR-1010X-07
	12 x 12	130	SDACL-1212X-07	SDACR-1212X-07
	12 x 12	90	SDACL-1212G-07	SDACR-1212G-07
	12.7 x 12.7	130	SDACL-12.7X-07	SDACR-12.7X-07
	16 x 16	130	SDACL-1616X-07	SDACR-1616X-07
	16 x 16	75	SDACL-1616F-07	SDACR-1616F-07
DC..-11T3..	12 x 12	130	SDACL-1212X-11	SDACR-1212X-11
	12 x 12	90	SDACL-1212G-11	SDACR-1212G-11
	12.7 x 12.7	130	SDACL-12.7X-11	SDACR-12.7X-11
	16 x 16	130	SDACL-1616X-11	SDACR-1616X-11
	16 x 16	75	SDACL-1616F-11	SDACR-1616F-11
	20 x 20	120	SDACL-2020X-11	SDACR-2020X-11

Porte-outils

Halter

Holders

55°

SDJ



SDJ

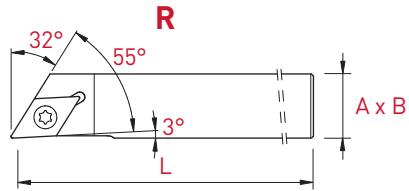

Plaquettes WSP Inserts	A x B	L	Art. N°	Art. N°
DC...-0702..	8 x 8	115	SDJCL-0808X-07	SDJCR-0808X-07
	10 x 10	115	SDJCL-1010X-07	SDJCR-1010X-07
	12 x 12	130	SDJCL-1212X-07	SDJCR-1212X-07
	12 x 12	90	SDJCL-1212G-07	SDJCR-1212G-07
	12.7 x 12.7	130	SDJCL-12.7X-07	SDJCR-12.7X-07
	16 x 16	130	SDJCL-1616X-07	SDJCR-1616X-07
	16 x 16	75	SDJCL-1616F-07	SDJCR-1616F-07
	20 x 20	120	SDJCL-2020X-07	SDJCR-2020X-07
DC...-11T3..	12 x 12	130	SDJCL-1212X-11	SDJCR-1212X-11
	12 x 12	90	SDJCL-1212G-11	SDJCR-1212G-11
	12.7 x 12.7	130	SDJCL-12.7X-11	SDJCR-12.7X-11
	16 x 16	130	SDJCL-1616X-11	SDJCR-1616X-11
	16 x 16	75	SDJCL-1616F-11	SDJCR-1616F-11
	20 x 20	120	SDJCL-2020X-11	SDJCR-2020X-11

# ISO-LINE

Porte-outils avec arrosage intégré  
 Halter mit integrierter Kühlmittelzufuhr  
 Holders with integrated coolant supply

55°

SDJ-JET

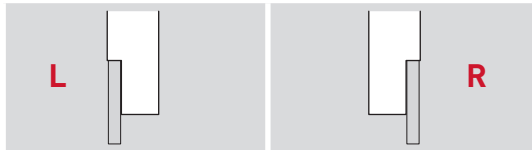
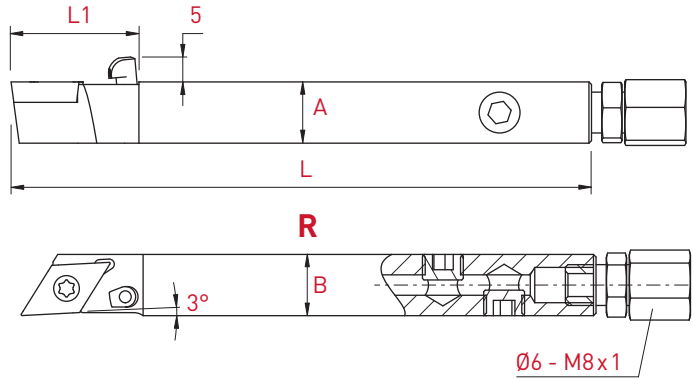

Plaquettes WSP Inserts	A x B	L	L1	Art. N°	Art. N°
DC...-0702..	10 x 10	110	20	SDJCL-1010J-07-JET	SDJCR-1010J-07-JET
	12 x 12	110	20	SDJCL-1212J-07-JET	SDJCR-1212J-07-JET
	12.7 x 12.7	110	20	SDJCL-12.7J-07-JET	SDJCR-12.7J-07-JET
	16 x 16	110	20	SDJCL-1616J-07-JET	SDJCR-1616J-07-JET
	20 x 20	110	20	SDJCL-2020J-07-JET	SDJCR-2020J-07-JET
DC...-11T3..	12 x 12	110	23	SDJCL-1212J-11-JET	SDJCR-1212J-11-JET
	12.7 x 12.7	110	23	SDJCL-12.7J-11-JET	SDJCR-12.7J-11-JET
	16 x 16	110	23	SDJCL-1616J-11-JET	SDJCR-1616J-11-JET
	20 x 20	110	23	SDJCL-2020J-11-JET	SDJCR-2020J-11-JET

Porte-outils

Halter

Holders

55°

SDH



SDH

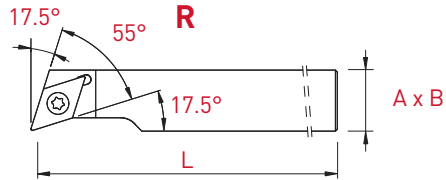

Plaquettes WSP Inserts	A x B	L	Art. N°	Art. N°
DC...-0702..	10 x 10	115	SDHCL-1010X-07	SDHCR-1010X-07
	12 x 12	130	SDHCL-1212X-07	SDHCR-1212X-07
	12 x 12	90	SDHCL-1212G-07	SDHCR-1212G-07
	12.7 x 12.7	130	SDHCL-12.7X-07	SDHCR-12.7X-07
	16 x 16	130	SDHCL-1616X-07	SDHCR-1616X-07
	16 x 16	75	SDHCL-1616F-07	SDHCR-1616F-07
DC...-11T3..	16 x 16	130	SDHCL-1616X-11	SDHCR-1616X-11
	16 x 16	75	SDHCL-1616F-11	SDHCR-1616F-11
	20 x 20	120	SDHCL-2020X-11	SDHCR-2020X-11

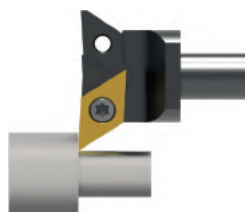

SDU

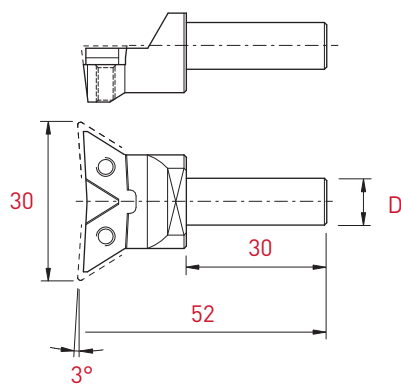

Plaquettes WSP Inserts	D	Art. N°
DC..-11T3..	10	<b>SDUC-D10X-11</b>

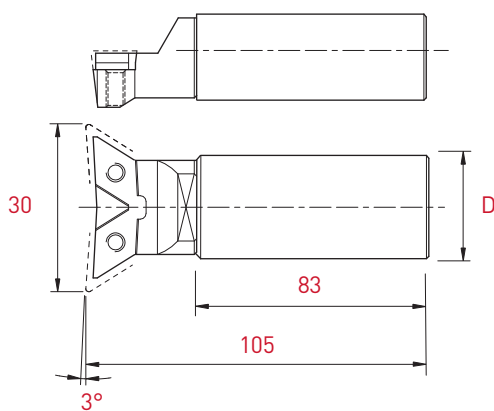

Plaquettes WSP Inserts	D	Art. N°
DC..-11T3..	20	<b>SDUC-D20X-11</b>
	25.4	<b>SDUC-D25.4X-11</b>



Porte-outils intérieurs amincis

Verjüngte Innenhalter

Thinned internal holders

55°

A-SDQCR/L

new

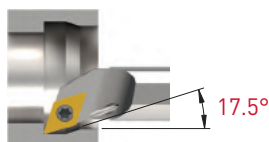

SDQ

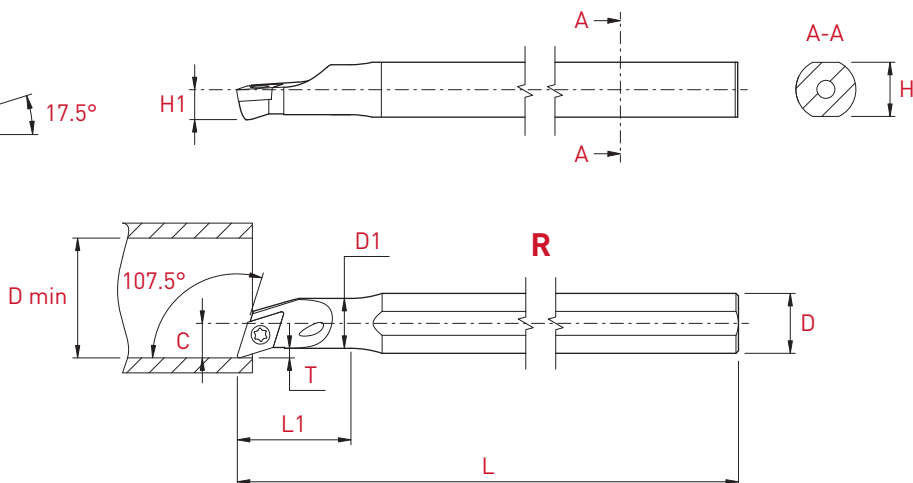

Acier / Stahl / Steel

L

R

Plaquettes WSP Inserts	D	D min	D1	T	C	H1	L	L1	H	Art. N°	Art. N°
	DC...-0702	10 12	12.5 15.5	8 10	2.4 2.9	7 9	5 6	100 125	22 28	9 11	A0810H-SDQCL-07 A1012K-SDQCL-07

Pour barres d'alésage  
For boring bar  
Für Borstange

Pièces de rechange  
Ersatzteile  
Spare parts

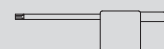
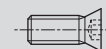

Art. N°

Art. N°

A0810H\_

V-M2.5X4.8-T8

C-T8

A1012K\_

V-M2.5X5.8-T8

**new**

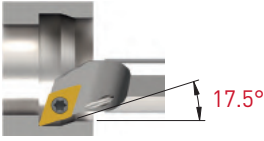

SDQ

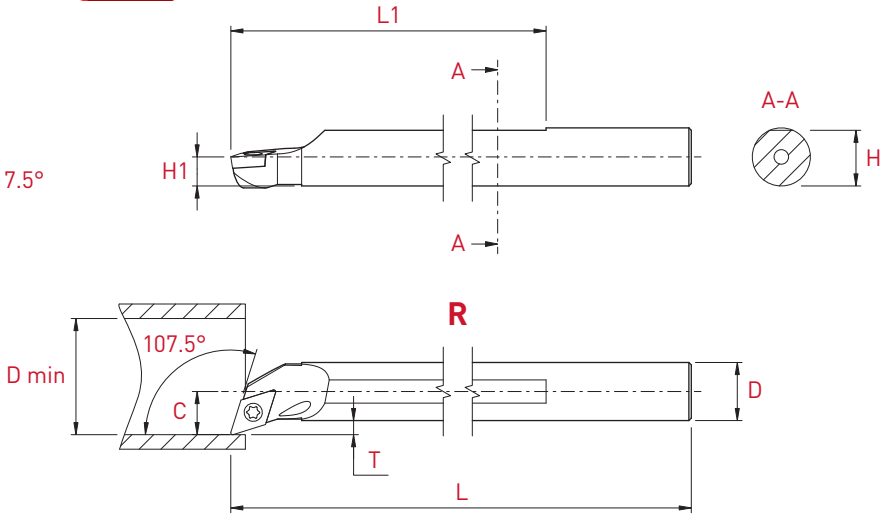

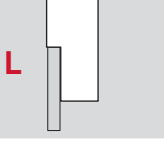
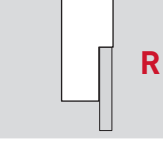
Acier / Stahl / Steel										
Plaquettes WSP Inserts	D	D min	T	C	H1	L	L1	H	Art. N°	Art. N°
DC...-0702	10	14	2.4	7	4.5	100	85	9	A10H-SDQCL-07	A10H-SDQCR-07
	12	17	2.9	9	6	125	95	11.5	A12K-SDQCL-07	A12K-SDQCR-07
	16	21	2.9	11	8	150	117	15.5	A16M-SDQCL-07	A16M-SDQCR-07

Carbure de tungstène / Hartmetall / Solid carbide										
	D	D min	T	C	H1	L	L1	H	Art. N°	Art. N°
DC...-0702	10	13	2.4	7.5	5	125	-	9.5	E10K-SDQCL-07	E10K-SDQCR-07
	12	17	2.9	9	6	150	-	11.5	E12M-SDQCL-07	E12M-SDQCR-07

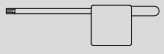
Pièces de rechange Ersatzteile Spare parts	
	
Art. N°	Art. N°
V-M2.5X5.8-T8	C-T8

Porte-outils intérieurs amincis

Verjüngte Innenhalter

Thinned internal holders

55°

A-SDUCR/L

new

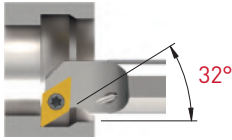

SDU

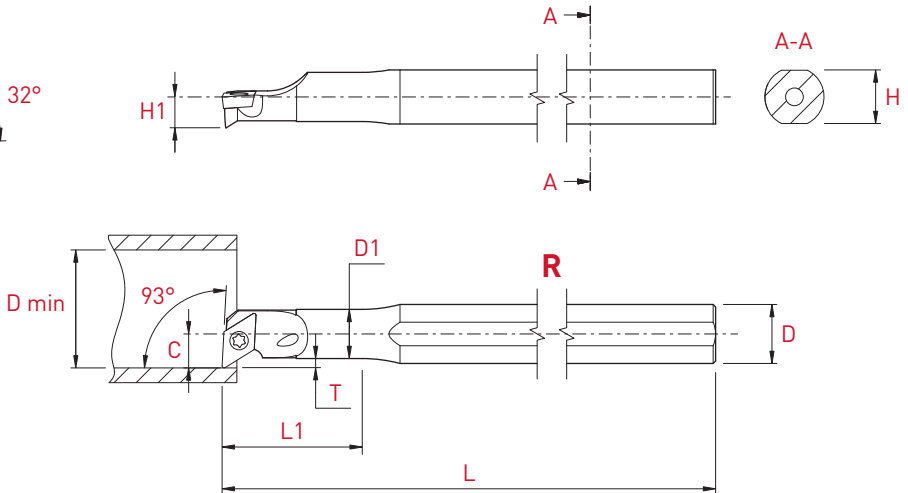

Acier / Stahl / Steel

L

R

Plaquettes WSP Inserts	D	D min	D1	T	C	H1	L	H	Art. N°	Art. N°
	DC...0702	10 12	12.5 15.5	7 9	1.9 2.9	5 6	100 125	22 28	9 11	A0810H-SDUCL-07 A1012K-SDUCL-07

Pour barres d'alésage  
For boring bar  
Für Borstange

Pièces de rechange  
Ersatzteile  
Spare parts

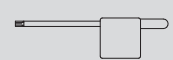
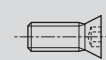

Art. N°

Art. N°

A0810H\_

V-M2.5X4.8-T8

C-T8

A1012K\_

V-M2.5X5.8-T8

**new**

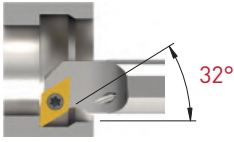

SDU

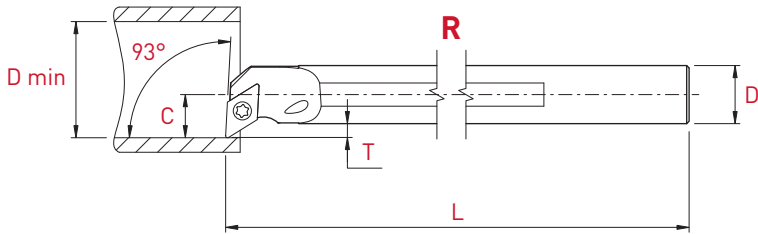
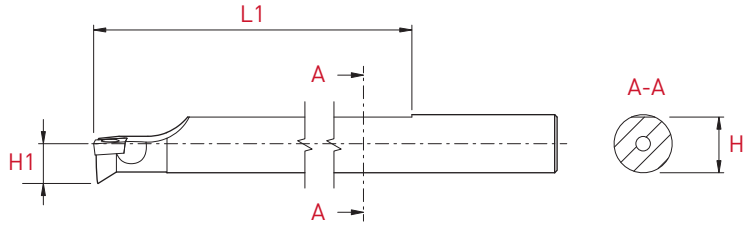

Acier / Stahl / Steel										
-----------------------	--	--	--	--	--	--	--	--	--	--

Plaquettes WSP Inserts	D	D min	T	C	H1	L	L1	H	Art. N°	Art. N°
	DC...-0702	10	14	1.9	7	5	100	85	9.5	A10H-SDUCL-07
12		17	2.9	9	6	125	95	11.5	A12K-SDUCL-07	A12K-SDUCR-07
16		21	2.9	11	8	150	117	15.5	A16M-SDUCL-07	A16M-SDUCR-07

Carbure de tungstène / Hartmetall / Solid carbide									Art. N°	Art. N°
D	D min	T	C	H1	L	L1	H	Art. N°	Art. N°	
DC...-0702	10	14	1.9	7	5	125	-	9.5	E10K-SDUCL-07	E10K-SDUCR-07
	12	17	2.9	9	6	150	-	11.5	E12M-SDUCL-07	E12M-SDUCR-07

Pièces de rechange Ersatzteile Spare parts	
Art. N°	Art. N°
V-M2.5X5.8-T8	C-T8

Plaquettes en métal dur

VHM-Wendepplatten

Solid carbide inserts

55°

DCGT-X8



DCGT  
FN-X8

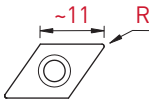
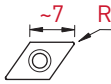

R	Art. N°	PVD					non revêtu unbeschichtet uncoated	
		TiAlN	HTA	TiAlX	HTAX	TiN	K10	K20
0.05	DCGT-0702005-FN-X8	<input checked="" type="checkbox"/>	<input checked="" type="checkbox"/>	<input checked="" type="checkbox"/>	<input checked="" type="checkbox"/>	<input checked="" type="checkbox"/>	<input type="checkbox"/>	<input type="checkbox"/>
0.08	DCGT-0702008-FN-X8	<input checked="" type="checkbox"/>	<input checked="" type="checkbox"/>	<input checked="" type="checkbox"/>	<input checked="" type="checkbox"/>	<input checked="" type="checkbox"/>	<input type="checkbox"/>	<input type="checkbox"/>
0.1	DCGT-070201-FN-X8	<input checked="" type="checkbox"/>	<input checked="" type="checkbox"/>	<input checked="" type="checkbox"/>	<input checked="" type="checkbox"/>	<input checked="" type="checkbox"/>	<input type="checkbox"/>	<input type="checkbox"/>
0.15	DCGT-0702015-FN-X8	<input checked="" type="checkbox"/>	<input checked="" type="checkbox"/>	<input checked="" type="checkbox"/>	<input checked="" type="checkbox"/>	<input checked="" type="checkbox"/>	<input type="checkbox"/>	<input type="checkbox"/>
0.2	DCGT-070202-FN-X8	<input checked="" type="checkbox"/>	<input checked="" type="checkbox"/>	<input checked="" type="checkbox"/>	<input checked="" type="checkbox"/>	<input checked="" type="checkbox"/>	<input type="checkbox"/>	<input type="checkbox"/>
0.4	DCGT-070204-FN-X8	<input checked="" type="checkbox"/>	<input checked="" type="checkbox"/>	<input checked="" type="checkbox"/>	<input checked="" type="checkbox"/>	<input checked="" type="checkbox"/>	<input type="checkbox"/>	<input type="checkbox"/>
0.05	DCGT-11T3005-FN-X8	<input checked="" type="checkbox"/>	<input checked="" type="checkbox"/>	<input checked="" type="checkbox"/>	<input checked="" type="checkbox"/>	<input checked="" type="checkbox"/>	<input type="checkbox"/>	<input type="checkbox"/>
0.08	DCGT-11T3008-FN-X8	<input checked="" type="checkbox"/>	<input checked="" type="checkbox"/>	<input checked="" type="checkbox"/>	<input checked="" type="checkbox"/>	<input checked="" type="checkbox"/>	<input type="checkbox"/>	<input type="checkbox"/>
0.1	DCGT-11T301-FN-X8	<input checked="" type="checkbox"/>	<input checked="" type="checkbox"/>	<input checked="" type="checkbox"/>	<input checked="" type="checkbox"/>	<input checked="" type="checkbox"/>	<input type="checkbox"/>	<input type="checkbox"/>
0.15	DCGT-11T3015-FN-X8	<input checked="" type="checkbox"/>	<input checked="" type="checkbox"/>	<input checked="" type="checkbox"/>	<input checked="" type="checkbox"/>	<input checked="" type="checkbox"/>	<input type="checkbox"/>	<input type="checkbox"/>
0.2	DCGT-11T302-FN-X8	<input checked="" type="checkbox"/>	<input checked="" type="checkbox"/>	<input checked="" type="checkbox"/>	<input checked="" type="checkbox"/>	<input checked="" type="checkbox"/>	<input type="checkbox"/>	<input type="checkbox"/>
0.4	DCGT-11T304-FN-X8	<input checked="" type="checkbox"/>	<input checked="" type="checkbox"/>	<input checked="" type="checkbox"/>	<input checked="" type="checkbox"/>	<input checked="" type="checkbox"/>	<input type="checkbox"/>	<input type="checkbox"/>



DCGT  
ENP-X8

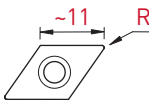
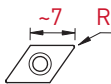

R	Art. N°	PVD		non revêtu unbeschichtet uncoated
		TiAlN	TiN	K20
0.05	DCGT-0702005-ENP-X8	<input checked="" type="checkbox"/>	<input checked="" type="checkbox"/>	<input type="checkbox"/>
0.08	DCGT-0702008-ENP-X8	<input checked="" type="checkbox"/>	<input checked="" type="checkbox"/>	<input type="checkbox"/>
0.1	DCGT-070201-ENP-X8	<input checked="" type="checkbox"/>	<input checked="" type="checkbox"/>	<input type="checkbox"/>
0.15	DCGT-0702015-ENP-X8	<input checked="" type="checkbox"/>	<input checked="" type="checkbox"/>	<input type="checkbox"/>
0.2	DCGT-070202-ENP-X8	<input checked="" type="checkbox"/>	<input checked="" type="checkbox"/>	<input type="checkbox"/>
0.4	DCGT-070204-ENP-X8	<input checked="" type="checkbox"/>	<input checked="" type="checkbox"/>	<input type="checkbox"/>
0.05	DCGT-11T3005-ENP-X8	<input checked="" type="checkbox"/>	<input checked="" type="checkbox"/>	<input type="checkbox"/>
0.08	DCGT-11T3008-ENP-X8	<input checked="" type="checkbox"/>	<input checked="" type="checkbox"/>	<input type="checkbox"/>
0.1	DCGT-11T301-ENP-X8	<input checked="" type="checkbox"/>	<input checked="" type="checkbox"/>	<input type="checkbox"/>
0.15	DCGT-11T3015-ENP-X8	<input checked="" type="checkbox"/>	<input checked="" type="checkbox"/>	<input type="checkbox"/>
0.2	DCGT-11T302-ENP-X8	<input checked="" type="checkbox"/>	<input checked="" type="checkbox"/>	<input type="checkbox"/>
0.4	DCGT-11T304-ENP-X8	<input checked="" type="checkbox"/>	<input checked="" type="checkbox"/>	<input type="checkbox"/>



DCGT  
FN-X17

R	Art. N°	PVD					non revêtu unbeschichtet uncoated	
		TiAlN	HTA	TiAlX	HTAX	TiN	K10	K20
0.05	DCGT-0702005-FN-X17	<input checked="" type="checkbox"/>	<input checked="" type="checkbox"/>	<input checked="" type="checkbox"/>	<input checked="" type="checkbox"/>	<input checked="" type="checkbox"/>	<input type="checkbox"/>	<input type="checkbox"/>
0.08	DCGT-0702008-FN-X17	<input checked="" type="checkbox"/>	<input checked="" type="checkbox"/>	<input checked="" type="checkbox"/>	<input checked="" type="checkbox"/>	<input checked="" type="checkbox"/>	<input type="checkbox"/>	<input type="checkbox"/>
0.1	DCGT-070201-FN-X17	<input checked="" type="checkbox"/>	<input checked="" type="checkbox"/>	<input checked="" type="checkbox"/>	<input checked="" type="checkbox"/>	<input checked="" type="checkbox"/>	<input type="checkbox"/>	<input type="checkbox"/>
0.15	DCGT-0702015-FN-X17	<input checked="" type="checkbox"/>	<input checked="" type="checkbox"/>	<input checked="" type="checkbox"/>	<input checked="" type="checkbox"/>	<input checked="" type="checkbox"/>	<input type="checkbox"/>	<input type="checkbox"/>
0.2	DCGT-070202-FN-X17	<input checked="" type="checkbox"/>	<input checked="" type="checkbox"/>	<input checked="" type="checkbox"/>	<input checked="" type="checkbox"/>	<input checked="" type="checkbox"/>	<input type="checkbox"/>	<input type="checkbox"/>
0.4	DCGT-070204-FN-X17	<input checked="" type="checkbox"/>	<input checked="" type="checkbox"/>	<input checked="" type="checkbox"/>	<input checked="" type="checkbox"/>	<input checked="" type="checkbox"/>	<input type="checkbox"/>	<input type="checkbox"/>
0.05	DCGT-11T3005-FN-X17	<input checked="" type="checkbox"/>	<input checked="" type="checkbox"/>	<input checked="" type="checkbox"/>	<input checked="" type="checkbox"/>	<input checked="" type="checkbox"/>	<input type="checkbox"/>	<input type="checkbox"/>
0.08	DCGT-11T3008-FN-X17	<input checked="" type="checkbox"/>	<input checked="" type="checkbox"/>	<input checked="" type="checkbox"/>	<input checked="" type="checkbox"/>	<input checked="" type="checkbox"/>	<input type="checkbox"/>	<input type="checkbox"/>
0.1	DCGT-11T301-FN-X17	<input checked="" type="checkbox"/>	<input checked="" type="checkbox"/>	<input checked="" type="checkbox"/>	<input checked="" type="checkbox"/>	<input checked="" type="checkbox"/>	<input type="checkbox"/>	<input type="checkbox"/>
0.15	DCGT-11T3015-FN-X17	<input checked="" type="checkbox"/>	<input checked="" type="checkbox"/>	<input checked="" type="checkbox"/>	<input checked="" type="checkbox"/>	<input checked="" type="checkbox"/>	<input type="checkbox"/>	<input type="checkbox"/>
0.2	DCGT-11T302-FN-X17	<input checked="" type="checkbox"/>	<input checked="" type="checkbox"/>	<input checked="" type="checkbox"/>	<input checked="" type="checkbox"/>	<input checked="" type="checkbox"/>	<input type="checkbox"/>	<input type="checkbox"/>
0.4	DCGT-11T304-FN-X17	<input checked="" type="checkbox"/>	<input checked="" type="checkbox"/>	<input checked="" type="checkbox"/>	<input checked="" type="checkbox"/>	<input checked="" type="checkbox"/>	<input type="checkbox"/>	<input type="checkbox"/>
0.8	DCGT-11T308-FN-X17	<input checked="" type="checkbox"/>	<input checked="" type="checkbox"/>	<input checked="" type="checkbox"/>	<input checked="" type="checkbox"/>	<input checked="" type="checkbox"/>	<input type="checkbox"/>	<input type="checkbox"/>

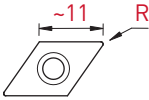
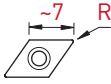

DCGT  
ENP-X17

R	Art. N°	PVD		non revêtu unbeschichtet uncoated
		TiAlN	TiN	K20
0.05	DCGT-0702005-ENP-X17	<input checked="" type="checkbox"/>	<input checked="" type="checkbox"/>	<input type="checkbox"/>
0.08	DCGT-0702008-ENP-X17	<input checked="" type="checkbox"/>	<input checked="" type="checkbox"/>	<input type="checkbox"/>
0.1	DCGT-070201-ENP-X17	<input checked="" type="checkbox"/>	<input checked="" type="checkbox"/>	<input type="checkbox"/>
0.15	DCGT-0702015-ENP-X17	<input checked="" type="checkbox"/>	<input checked="" type="checkbox"/>	<input type="checkbox"/>
0.2	DCGT-070202-ENP-X17	<input checked="" type="checkbox"/>	<input checked="" type="checkbox"/>	<input type="checkbox"/>
0.4	DCGT-070204-ENP-X17	<input checked="" type="checkbox"/>	<input checked="" type="checkbox"/>	<input type="checkbox"/>
0.05	DCGT-11T3005-ENP-X17	<input checked="" type="checkbox"/>	<input checked="" type="checkbox"/>	<input type="checkbox"/>
0.08	DCGT-11T3008-ENP-X17	<input checked="" type="checkbox"/>	<input checked="" type="checkbox"/>	<input type="checkbox"/>
0.1	DCGT-11T301-ENP-X17	<input checked="" type="checkbox"/>	<input checked="" type="checkbox"/>	<input type="checkbox"/>
0.15	DCGT-11T3015-ENP-X17	<input checked="" type="checkbox"/>	<input checked="" type="checkbox"/>	<input type="checkbox"/>
0.2	DCGT-11T302-ENP-X17	<input checked="" type="checkbox"/>	<input checked="" type="checkbox"/>	<input type="checkbox"/>
0.4	DCGT-11T304-ENP-X17	<input checked="" type="checkbox"/>	<input checked="" type="checkbox"/>	<input type="checkbox"/>
0.8	DCGT-11T308-ENP-X17	<input checked="" type="checkbox"/>	<input checked="" type="checkbox"/>	<input type="checkbox"/>

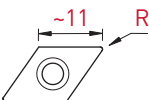
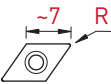





**DCCT**  
**ENP-X20**

PVD	
<input type="checkbox"/>	<input type="checkbox"/>
<input checked="" type="checkbox"/> M	<input checked="" type="checkbox"/> M
<input checked="" type="checkbox"/> N	<input checked="" type="checkbox"/> N
<input checked="" type="checkbox"/> S	<input checked="" type="checkbox"/> S
ZTA	HTiX

R	H	Art. N°	ZTA	HTiX
0.1	0.2	DCCT-070201-ENP-X20	■	
0.2	0.2	DCCT-070202-ENP-X20	■	■
0.4	0.2	DCCT-070204-ENP-X20	■	■
0.1	0.25	DCCT-11T301-ENP-X20	■	
0.2	0.25	DCCT-11T302-ENP-X20	■	■
0.4	0.25	DCCT-11T304-ENP-X20	■	■
0.8	0.25	DCCT-11T308-ENP-X20	■	■

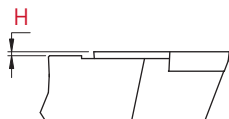
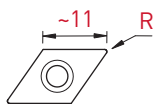
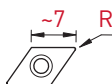



Plaquettes en métal dur

VHM-Wendepplatten

Solid carbide inserts

55°

DCMT-XF3

DCMT-XF2

DCMT-MF2

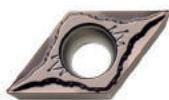

DCMT  
EN-XF3

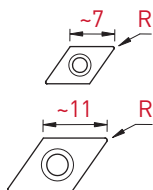

R	Art. N°	PVD	
		TAC	HTAC
0.2	DCMT-070202-EN-XF3	<input checked="" type="checkbox"/>	<input checked="" type="checkbox"/>
0.4	DCMT-070204-EN-XF3	<input checked="" type="checkbox"/>	<input checked="" type="checkbox"/>
0.2	DCMT-11T302-EN-XF3	<input checked="" type="checkbox"/>	<input checked="" type="checkbox"/>
0.4	DCMT-11T304-EN-XF3	<input checked="" type="checkbox"/>	<input checked="" type="checkbox"/>

PVD	
<input checked="" type="checkbox"/> P	<input checked="" type="checkbox"/> P
<input checked="" type="checkbox"/> M	<input checked="" type="checkbox"/> M
<input checked="" type="checkbox"/> N	<input checked="" type="checkbox"/> N
<input checked="" type="checkbox"/> S	<input checked="" type="checkbox"/> S

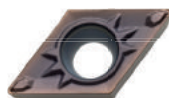

DCMT  
EN-XF2

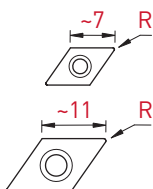

R	Art. N°	PVD		CVD
		TAC	HTAC	HT15
0.2	DCMT-070202-EN-XF2	<input checked="" type="checkbox"/>	<input checked="" type="checkbox"/>	<input checked="" type="checkbox"/>
0.4	DCMT-070204-EN-XF2	<input checked="" type="checkbox"/>	<input checked="" type="checkbox"/>	<input checked="" type="checkbox"/>
0.2	DCMT-11T302-EN-XF2	<input checked="" type="checkbox"/>	<input checked="" type="checkbox"/>	<input checked="" type="checkbox"/>
0.4	DCMT-11T304-EN-XF2	<input checked="" type="checkbox"/>	<input checked="" type="checkbox"/>	<input checked="" type="checkbox"/>

PVD		CVD
<input checked="" type="checkbox"/> P	<input checked="" type="checkbox"/> P	<input checked="" type="checkbox"/> P
<input checked="" type="checkbox"/> M	<input checked="" type="checkbox"/> M	<input checked="" type="checkbox"/> M
<input checked="" type="checkbox"/> N	<input checked="" type="checkbox"/> N	<input type="checkbox"/>
<input checked="" type="checkbox"/> S	<input checked="" type="checkbox"/> S	<input type="checkbox"/>



DCMT  
EN-MF2

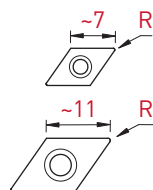

R	Art. N°	PVD		CVD	
		TAC	HTAC	Ti5	HT15
0.2	DCMT-070202-EN-MF2	<input checked="" type="checkbox"/>	<input checked="" type="checkbox"/>	<input checked="" type="checkbox"/>	<input checked="" type="checkbox"/>
0.4	DCMT-070204-EN-MF2	<input checked="" type="checkbox"/>	<input checked="" type="checkbox"/>	<input checked="" type="checkbox"/>	<input checked="" type="checkbox"/>
0.2	DCMT-11T302-EN-MF2	<input checked="" type="checkbox"/>	<input checked="" type="checkbox"/>	<input checked="" type="checkbox"/>	<input checked="" type="checkbox"/>
0.4	DCMT-11T304-EN-MF2	<input checked="" type="checkbox"/>	<input checked="" type="checkbox"/>	<input checked="" type="checkbox"/>	<input checked="" type="checkbox"/>
0.8	DCMT-11T308-EN-MF2	<input checked="" type="checkbox"/>	<input checked="" type="checkbox"/>	<input checked="" type="checkbox"/>	<input checked="" type="checkbox"/>

PVD		CVD	
<input checked="" type="checkbox"/> P	<input checked="" type="checkbox"/> P	<input checked="" type="checkbox"/> P	<input checked="" type="checkbox"/> P
<input checked="" type="checkbox"/> M	<input checked="" type="checkbox"/> M	<input checked="" type="checkbox"/> M	<input checked="" type="checkbox"/> M
<input checked="" type="checkbox"/> N	<input checked="" type="checkbox"/> N	<input type="checkbox"/>	<input type="checkbox"/>
<input checked="" type="checkbox"/> S	<input checked="" type="checkbox"/> S	<input type="checkbox"/>	<input type="checkbox"/>

# ISO-LINE

Plaquettes en métal dur  
VHM-Wendplatten  
Solid carbide inserts

55°

DCMT-MF  
DCMT-HF3  
DCMT-HF

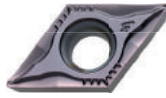

**DCMT  
EN-MF**

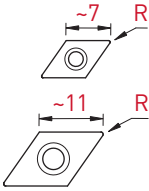

R	Art. N°	PVD		CVD	
		<input type="checkbox"/> P <input checked="" type="checkbox"/> M <input type="checkbox"/>	<input type="checkbox"/> P <input checked="" type="checkbox"/> M <input type="checkbox"/>	<input type="checkbox"/> P <input checked="" type="checkbox"/> M <input type="checkbox"/>	<input type="checkbox"/> P <input checked="" type="checkbox"/> M <input type="checkbox"/>
		Tmax		Ti4	
0.2	DCMT-070202-EN-MF	■		■	
0.4	DCMT-070204-EN-MF	■		■	
0.2	DCMT-11T302-EN-MF	■		■	
0.4	DCMT-11T304-EN-MF	■		■	



**DCMT  
EN-HF3**

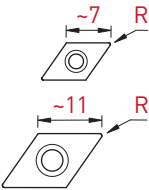

R	Art. N°	PVD		CVD	
		<input checked="" type="checkbox"/> P <input checked="" type="checkbox"/> M <input type="checkbox"/>	<input checked="" type="checkbox"/> P <input checked="" type="checkbox"/> M <input type="checkbox"/>	<input type="checkbox"/> P <input checked="" type="checkbox"/> M <input type="checkbox"/>	<input type="checkbox"/> P <input checked="" type="checkbox"/> M <input type="checkbox"/>
		TiX	HTiX	Ti6	
0.2	DCMT-070202-EN-HF3	■	■	■	
0.4	DCMT-070204-EN-HF3	■	■	■	
0.2	DCMT-11T302-EN-HF3	■	■	■	
0.4	DCMT-11T304-EN-HF3	■	■	■	
0.8	DCMT-11T308-EN-HF3	■	■	■	



**DCMT  
EN-HF**

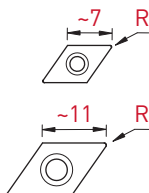

R	Art. N°	PVD			CVD		
		<input checked="" type="checkbox"/> P <input checked="" type="checkbox"/> M <input type="checkbox"/>	<input checked="" type="checkbox"/> P <input checked="" type="checkbox"/> M <input type="checkbox"/>	<input type="checkbox"/> P <input type="checkbox"/> M <input type="checkbox"/>	<input checked="" type="checkbox"/> P <input checked="" type="checkbox"/> M <input type="checkbox"/>	<input checked="" type="checkbox"/> P <input checked="" type="checkbox"/> M <input type="checkbox"/>	<input checked="" type="checkbox"/> P <input checked="" type="checkbox"/> M <input type="checkbox"/>
		Tmax	TAC	Ti4	Ti5	HTi5	
0.2	DCMT-070202-EN-HF	■		■		■	
0.4	DCMT-070204-EN-HF	■		■		■	
0.8	DCMT-070208-EN-HF	■		■		■	
0.2	DCMT-11T302-EN-HF	■		■		■	
0.4	DCMT-11T304-EN-HF	■		■		■	
0.8	DCMT-11T308-EN-HF	■		■		■	

Plaquettes CERMET  
 CERMET-Wendeplatten  
 CERMET inserts

55°

DCGT-X8  
 DCGT-KX



DCGT  
 FN-X8

		CERMET	
		PVD	non revêtu unbeschichtet uncoated
		<input type="checkbox"/> P <input type="checkbox"/> M <input type="checkbox"/>	<input type="checkbox"/> P <input type="checkbox"/> <input type="checkbox"/>
R	Art. N°	CTA	CN6
0.05	DCGT-0702005-FN-X8	<input checked="" type="checkbox"/>	<input checked="" type="checkbox"/>
0.1	DCGT-070201-FN-X8	<input checked="" type="checkbox"/>	<input checked="" type="checkbox"/>
0.2	DCGT-070202-FN-X8	<input checked="" type="checkbox"/>	<input checked="" type="checkbox"/>
0.05	DCGT-11T3005-FN-X8	<input checked="" type="checkbox"/>	<input checked="" type="checkbox"/>
0.1	DCGT-11T301-FN-X8	<input checked="" type="checkbox"/>	<input checked="" type="checkbox"/>
0.2	DCGT-11T302-FN-X8	<input checked="" type="checkbox"/>	<input checked="" type="checkbox"/>
0.4	DCGT-11T304-FN-X8	<input checked="" type="checkbox"/>	<input checked="" type="checkbox"/>

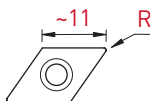
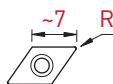

DCGT  
 ENP-KX

		CERMET		
		PVD		non revêtu unbeschichtet uncoated
		<input type="checkbox"/> P <input checked="" type="checkbox"/> M <input type="checkbox"/>	<input type="checkbox"/> P <input checked="" type="checkbox"/> M <input type="checkbox"/>	<input type="checkbox"/> P <input type="checkbox"/> <input type="checkbox"/>
R	Art. N°	CT7	HCT7	CN6
0.1	DCGT-070201-ENP-KX	<input checked="" type="checkbox"/>	<input checked="" type="checkbox"/>	<input checked="" type="checkbox"/>
0.2	DCGT-070202-ENP-KX	<input checked="" type="checkbox"/>	<input checked="" type="checkbox"/>	<input checked="" type="checkbox"/>
0.4	DCGT-070204-ENP-KX	<input checked="" type="checkbox"/>	<input checked="" type="checkbox"/>	<input checked="" type="checkbox"/>
0.1	DCGT-11T301-ENP-KX	<input checked="" type="checkbox"/>	<input checked="" type="checkbox"/>	<input checked="" type="checkbox"/>
0.2	DCGT-11T302-ENP-KX	<input checked="" type="checkbox"/>	<input checked="" type="checkbox"/>	<input checked="" type="checkbox"/>
0.4	DCGT-11T304-ENP-KX	<input checked="" type="checkbox"/>	<input checked="" type="checkbox"/>	<input checked="" type="checkbox"/>

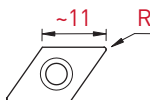
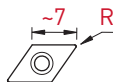



DCMT  
 EN-KM

		CERMET		
		PVD		non revêtu unbeschichtet uncoated
		P M	P M	P
		<input type="checkbox"/>	<input type="checkbox"/>	<input type="checkbox"/>
		<input type="checkbox"/>	<input type="checkbox"/>	<input type="checkbox"/>
		<input type="checkbox"/>	<input type="checkbox"/>	<input type="checkbox"/>
R	Art. N°	CT7	HCT7	CN6
0.2	DCMT-070202-EN-KM	■	■	■
0.4	DCMT-070204-EN-KM	■	■	■
0.2	DCMT-11T302-EN-KM	■	■	■
0.4	DCMT-11T304-EN-KM	■	■	■
0.8	DCMT-11T308-EN-KM	■	■	■

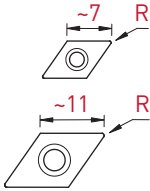

Porte-outils

Halter

Holders

35°

SVV



SVV

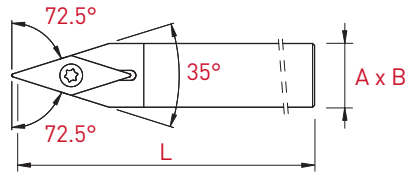

Plaquettes WSP Inserts	A x B	L	Art. N°
VC...1103..	8 x 8	115	SVVCN-0808X-11
	10 x 10	115	SVVCN-1010X-11
	12 x 12	130	SVVCN-1212X-11
	12 x 12	90	SVVCN-1212G-11
	12.7 x 12.7	130	SVVCN-12.7X-11
	16 x 16	130	SVVCN-1616X-11
	16 x 16	75	SVVCN-1616F-11
	20 x 20	120	SVVCN-2020X-11
VC...1303..	8 x 10	115	SVVCN-0810X-13
	10 x 10	115	SVVCN-1010X-13
	12 x 12	130	SVVCN-1212X-13
	12 x 12	90	SVVCN-1212G-13
	12.7 x 12.7	130	SVVCN-12.7X-13
	16 x 16	130	SVVCN-1616X-13
	16 x 16	75	SVVCN-1616F-13
	20 x 20	120	SVVCN-2020X-13
VC...1604..	12 x 12	130	SVVCN-1212X-16
	12 x 12	90	SVVCN-1212G-16
	12.7 x 12.7	130	SVVCN-12.7X-16
	16 x 16	130	SVVCN-1616X-16
	16 x 16	75	SVVCN-1616F-16
	20 x 20	120	SVVCN-2020X-16



SVA

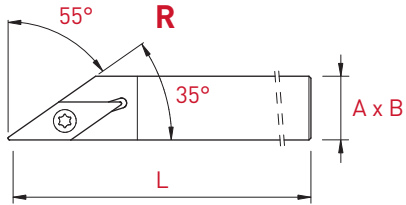

Plaquettes WSP Inserts	A x B	L	Art. N°	Art. N°
VC...-1103..	8 x 8	115	SVACL-0808X-11	SVACR-0808X-11
	10 x 10	115	SVACL-1010X-11	SVACR-1010X-11
	12 x 12	130	SVACL-1212X-11	SVACR-1212X-11
	12 x 12	90	SVACL-1212G-11	SVACR-1212G-11
	12.7 x 12.7	130	SVACL-12.7X-11	SVACR-12.7X-11
	16 x 16	130	SVACL-1616X-11	SVACR-1616X-11
	16 x 16	75	SVACL-1616F-11	SVACR-1616F-11
	20 x 20	120	SVACL-2020X-11	SVACR-2020X-11
VC...-1604..	12 x 12	130	SVACL-1212X-16	SVACR-1212X-16
	12 x 12	90	SVACL-1212G-16	SVACR-1212G-16
	12.7 x 12.7	130	SVACL-12.7X-16	SVACR-12.7X-16
	16 x 16	130	SVACL-1616X-16	SVACR-1616X-16
	16 x 16	75	SVACL-1616F-16	SVACR-1616F-16
	20 x 20	120	SVACL-2020X-16	SVACR-2020X-16

Porte-outils

Halter

Holders

35°

SVJ



SVJ

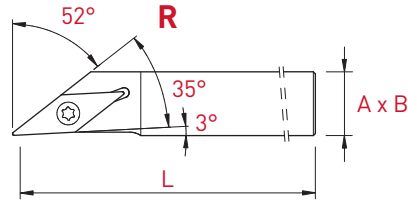

Plaquettes WSP Inserts	A x B	L	Art. N°	Art. N°
VC...1103..	8 x 8	115	SVJCL-0808X-11	SVJCR-0808X-11
	10 x 10	115	SVJCL-1010X-11	SVJCR-1010X-11
	12 x 12	130	SVJCL-1212X-11	SVJCR-1212X-11
	12 x 12	90	SVJCL-1212G-11	SVJCR-1212G-11
	12.7 x 12.7	130	SVJCL-12.7X-11	SVJCR-12.7X-11
	16 x 16	130	SVJCL-1616X-11	SVJCR-1616X-11
	16 x 16	75	SVJCL-1616F-11	SVJCR-1616F-11
	20 x 20	120	SVJCL-2020X-11	SVJCR-2020X-11
VC...1303..	8 x 10	115	SVJCL-0810X-13	SVJCR-0810X-13
	10 x 10	115	SVJCL-1010X-13	SVJCR-1010X-13
	12 x 12	130	SVJCL-1212X-13	SVJCR-1212X-13
	12 x 12	90	SVJCL-1212G-13	SVJCR-1212G-13
	12.7 x 12.7	130	SVJCL-12.7X-13	SVJCR-12.7X-13
	16 x 16	130	SVJCL-1616X-13	SVJCR-1616X-13
	16 x 16	75	SVJCL-1616F-13	SVJCR-1616F-13
	20 x 20	120	SVJCL-2020X-13	SVJCR-2020X-13
VC...1604..	12 x 12	130	SVJCL-1212X-16	SVJCR-1212X-16
	12 x 12	90	SVJCL-1212G-16	SVJCR-1212G-16
	12.7 x 12.7	130	SVJCL-12.7X-16	SVJCR-12.7X-16
	16 x 16	130	SVJCL-1616X-16	SVJCR-1616X-16
	16 x 16	75	SVJCL-1616F-16	SVJCR-1616F-16
	20 x 20	120	SVJCL-2020X-16	SVJCR-2020X-16

# ISO-LINE

Porte-outils avec arrosage intégré  
 Halter mit integrierter Kühlmittelzufuhr  
 Holders with integrated coolant supply

35°

SVJ-JET



SVJ

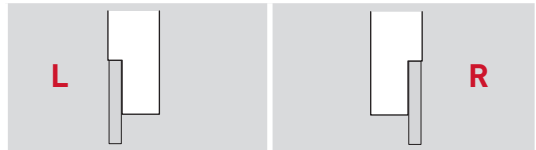
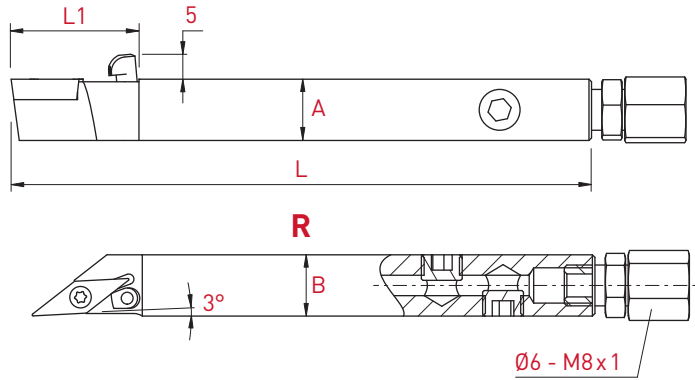

Plaquettes WSP Inserts	A x B	L	L1	Art. N°	Art. N°
VC...-1103..	10 x 10	110	21	SVJCL-1010J-11-JET	SVJCR-1010J-11-JET
	12 x 12	110	21	SVJCL-1212J-11-JET	SVJCR-1212J-11-JET
	12.7 x 12.7	110	21	SVJCL-12.7J-11-JET	SVJCR-12.7J-11-JET
	16 x 16	110	21	SVJCL-1616J-11-JET	SVJCR-1616J-11-JET
	20 x 20	110	21	SVJCL-2020J-11-JET	SVJCR-2020J-11-JET
VC...-1303..	10 x 10	110	26	SVJCL-1010J-13-JET	SVJCR-1010J-13-JET
	12 x 12	110	26	SVJCL-1212J-13-JET	SVJCR-1212J-13-JET
	12.7 x 12.7	110	26	SVJCL-12.7J-13-JET	SVJCR-12.7J-13-JET
	16 x 16	110	26	SVJCL-1616J-13-JET	SVJCR-1616J-13-JET
	20 x 20	110	26	SVJCL-2020J-13-JET	SVJCR-2020J-13-JET
VC...-1604..	12 x 12	110	30	SVJCL-1212J-16-JET	SVJCR-1212J-16-JET
	12.7 x 12.7	110	30	SVJCL-12.7J-16-JET	SVJCR-12.7J-16-JET
	16 x 16	110	30	SVJCL-1616J-16-JET	SVJCR-1616J-16-JET
	20 x 20	110	30	SVJCL-2020J-16-JET	SVJCR-2020J-16-JET



Porte-outils

Halter

Holders

35°

SVX



SVX

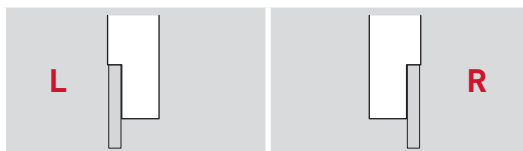
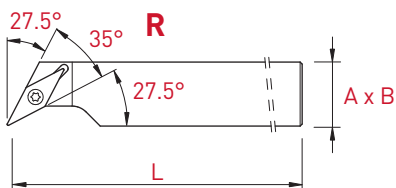

Plaquettes WSP Inserts	A x B	L	Art. N°	Art. N°
VC...-1103..	16 x 16	130	SVXCL-1616X-11	SVXCR-1616X-11
	16 x 16	75	SVXCL-1616F-11	SVXCR-1616F-11
	20 x 20	120	SVXCL-2020X-11	SVXCR-2020X-11

Porte-outils

Halter

Holders

35°

SV-CL/R



SV-CL/R

tournage arrière  
rückwärts drehen  
back turning

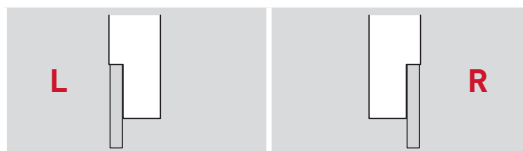
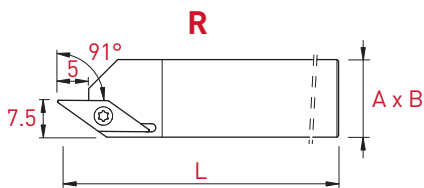

Plaquettes WSP Inserts	A x B	L	Art. N°	Art. N°
VCG...-1103..	12 x 12	130	SV-CL-1212X-11	SV-CR-1212X-11
	12 x 12	90	SV-CL-1212G-11	SV-CR-1212G-11
	12.7 x 12.7	130	SV-CL-12.7X-11	SV-CR-12.7X-11
	16 x 16	130	SV-CL-1616X-11	SV-CR-1616X-11
	16 x 16	75	SV-CL-1616F-11	SV-CR-1616F-11
	20 x 20	120	SV-CL-2020X-11	SV-CR-2020X-11

# ISO-LINE

Porte-outils compatibles avec plaquettes VCGT ELP/ERP-FL/FR-X10°

Passende Halter zu den Wendplatten VCGT ELP/ERP-FL/FR-X10°

Holders compatible with inserts VCGT ELP/ERP-FL/FR-X10°

35°

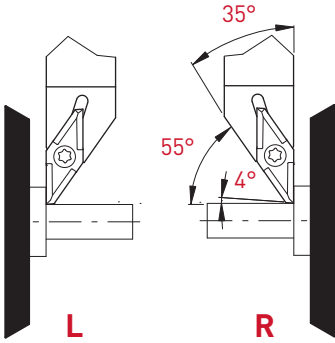

	Art. N°
R	SVACR-...-11
L	SVACL-...-11

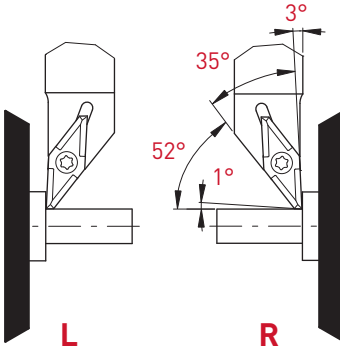

	Art. N°
R	SVJCR-...-11
L	SVJCL-...-11

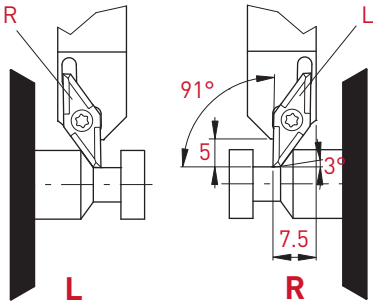

	Art. N°
R	SV-CR-...-11
L	SV-CL-...-11

Porte-outils intérieurs

Innenhalter

Internal holders

35°

A-SVUCR/L

new

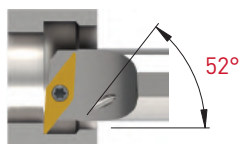

SVU

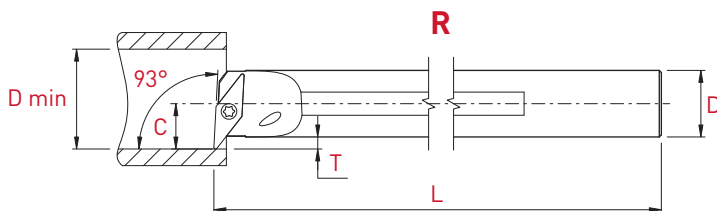
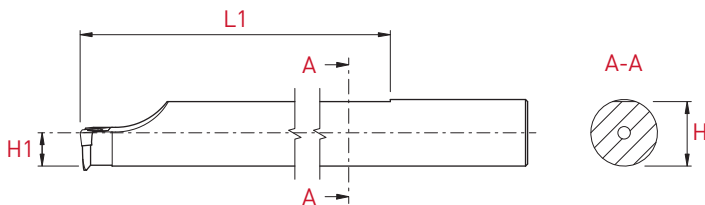

Acier / Stahl / Steel

L

R

Plaquettes WSP Inserts	D	Dmin	T	C	H1	L	L1	H	Art. N°	Art. N°
VC..-1103	16	21	3.1	11	8	150	118	15.5	A16M-SVUCL-11	A16M-SVUCR-11

Pièces de rechange  
Ersatzteile  
Spare parts



Art. N°

V-M2.5X5.8-T8

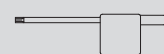

Art. N°

C-T8

Plaquettes en métal dur  
VHM-Wendepplatten  
Solid carbide inserts

35°

VCGT-L/R-X10



VCGT  
FL / FR-X10

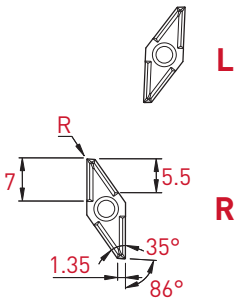

R	Art. N°	PVD					non revêtu unbeschichtet uncoated	
		TiAlN	HTA	TiAlX	HTAX	TiN	K10	K20
0.03	VCGT-1103003-FL-X10	<input checked="" type="checkbox"/>	<input checked="" type="checkbox"/>	<input type="checkbox"/>	<input type="checkbox"/>	<input type="checkbox"/>	<input type="checkbox"/>	<input type="checkbox"/>
0.08	VCGT-1103008-FL-X10	<input checked="" type="checkbox"/>	<input checked="" type="checkbox"/>	<input type="checkbox"/>	<input type="checkbox"/>	<input type="checkbox"/>	<input type="checkbox"/>	<input type="checkbox"/>
0.1	VCGT-110301-FL-X10	<input checked="" type="checkbox"/>	<input checked="" type="checkbox"/>	<input type="checkbox"/>	<input type="checkbox"/>	<input type="checkbox"/>	<input type="checkbox"/>	<input type="checkbox"/>
0.2	VCGT-110302-FL-X10	<input checked="" type="checkbox"/>	<input checked="" type="checkbox"/>	<input type="checkbox"/>	<input type="checkbox"/>	<input type="checkbox"/>	<input type="checkbox"/>	<input type="checkbox"/>
0.03	VCGT-1103003-FR-X10	<input checked="" type="checkbox"/>	<input checked="" type="checkbox"/>	<input checked="" type="checkbox"/>	<input checked="" type="checkbox"/>	<input checked="" type="checkbox"/>	<input type="checkbox"/>	<input type="checkbox"/>
0.08	VCGT-1103008-FR-X10	<input checked="" type="checkbox"/>	<input checked="" type="checkbox"/>	<input checked="" type="checkbox"/>	<input checked="" type="checkbox"/>	<input checked="" type="checkbox"/>	<input type="checkbox"/>	<input type="checkbox"/>
0.1	VCGT-110301-FR-X10	<input checked="" type="checkbox"/>	<input checked="" type="checkbox"/>	<input checked="" type="checkbox"/>	<input checked="" type="checkbox"/>	<input checked="" type="checkbox"/>	<input type="checkbox"/>	<input type="checkbox"/>
0.2	VCGT-110302-FR-X10	<input checked="" type="checkbox"/>	<input checked="" type="checkbox"/>	<input checked="" type="checkbox"/>	<input checked="" type="checkbox"/>	<input checked="" type="checkbox"/>	<input type="checkbox"/>	<input type="checkbox"/>



VCGT  
ELP/ERP-X10

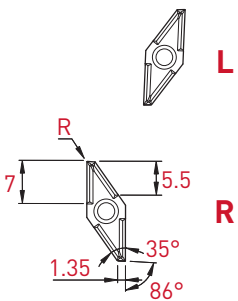

R	Art. N°	PVD					non revêtu unbeschichtet uncoated	
		TiAlN	HTA	TiAlX	HTAX	TiN	K10	K20
0.03	VCGT-1103003-ELP-X10	<input checked="" type="checkbox"/>	<input checked="" type="checkbox"/>	<input type="checkbox"/>	<input type="checkbox"/>	<input type="checkbox"/>	<input type="checkbox"/>	<input type="checkbox"/>
0.08	VCGT-1103008-ELP-X10	<input checked="" type="checkbox"/>	<input checked="" type="checkbox"/>	<input type="checkbox"/>	<input type="checkbox"/>	<input type="checkbox"/>	<input type="checkbox"/>	<input type="checkbox"/>
0.1	VCGT-110301-ELP-X10	<input checked="" type="checkbox"/>	<input checked="" type="checkbox"/>	<input type="checkbox"/>	<input type="checkbox"/>	<input type="checkbox"/>	<input type="checkbox"/>	<input type="checkbox"/>
0.2	VCGT-110302-ELP-X10	<input checked="" type="checkbox"/>	<input checked="" type="checkbox"/>	<input type="checkbox"/>	<input type="checkbox"/>	<input type="checkbox"/>	<input type="checkbox"/>	<input type="checkbox"/>
0.03	VCGT-1103003-ERP-X10	<input checked="" type="checkbox"/>	<input checked="" type="checkbox"/>	<input checked="" type="checkbox"/>	<input checked="" type="checkbox"/>	<input checked="" type="checkbox"/>	<input type="checkbox"/>	<input type="checkbox"/>
0.08	VCGT-1103008-ERP-X10	<input checked="" type="checkbox"/>	<input checked="" type="checkbox"/>	<input checked="" type="checkbox"/>	<input checked="" type="checkbox"/>	<input checked="" type="checkbox"/>	<input type="checkbox"/>	<input type="checkbox"/>
0.1	VCGT-110301-ERP-X10	<input checked="" type="checkbox"/>	<input checked="" type="checkbox"/>	<input checked="" type="checkbox"/>	<input checked="" type="checkbox"/>	<input checked="" type="checkbox"/>	<input type="checkbox"/>	<input type="checkbox"/>
0.2	VCGT-110302-ERP-X10	<input checked="" type="checkbox"/>	<input checked="" type="checkbox"/>	<input checked="" type="checkbox"/>	<input checked="" type="checkbox"/>	<input checked="" type="checkbox"/>	<input type="checkbox"/>	<input type="checkbox"/>

Plaquettes en métal dur

VHM-Wendeplatten

Solid carbide inserts

35°

VCGT-K18

VCGW-0



VCGT  
FN-K18

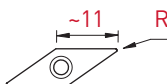

R	Art. N°	PVD		non revêtu unbeschichtet uncoated
		HTA	HTiN	K10
0.05	VCGT-1103005-FN-K18	■	■	■
0.1	VCGT-110301-FN-K18	■	■	■
0.2	VCGT-110302-FN-K18	■	■	■
0.4	VCGT-110304-FN-K18	■	■	■



VCGW  
FN-0

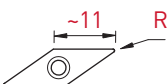

R	Art. N°	PVD		non revêtu unbeschichtet uncoated
		HTA	HTiN	K10
0.05	VCGW-1103005-FN-0	■	■	■
0.1	VCGW-110301-FN-0	■	■	■
0.2	VCGW-110302-FN-0	■	■	■
0.4	VCGW-110304-FN-0	■	■	■



### VCGT-FN-X8

R	Art. N°	PVD					non revêtu unbeschichtet uncoated	
		TiAlN	HTA	TiAlX	HTAX	TiN	K10	K20
		<input type="checkbox"/>	<input type="checkbox"/>	<input type="checkbox"/>	<input type="checkbox"/>	<input type="checkbox"/>	<input type="checkbox"/>	<input type="checkbox"/>
		<input type="checkbox"/>	<input type="checkbox"/>	<input checked="" type="checkbox"/>	<input checked="" type="checkbox"/>	<input type="checkbox"/>	<input type="checkbox"/>	<input type="checkbox"/>
0.05	VCGT-1103005-FN-X8	<input type="checkbox"/>	<input type="checkbox"/>	<input type="checkbox"/>	<input type="checkbox"/>	<input type="checkbox"/>	<input type="checkbox"/>	<input type="checkbox"/>
0.08	VCGT-1103008-FN-X8	<input type="checkbox"/>	<input type="checkbox"/>	<input type="checkbox"/>	<input type="checkbox"/>	<input type="checkbox"/>	<input type="checkbox"/>	<input type="checkbox"/>
0.1	VCGT-110301-FN-X8	<input type="checkbox"/>	<input type="checkbox"/>	<input type="checkbox"/>	<input type="checkbox"/>	<input type="checkbox"/>	<input type="checkbox"/>	<input type="checkbox"/>
0.15	VCGT-1103015-FN-X8	<input type="checkbox"/>	<input type="checkbox"/>	<input type="checkbox"/>	<input type="checkbox"/>	<input type="checkbox"/>	<input type="checkbox"/>	<input type="checkbox"/>
0.2	VCGT-110302-FN-X8	<input type="checkbox"/>	<input type="checkbox"/>	<input type="checkbox"/>	<input type="checkbox"/>	<input type="checkbox"/>	<input type="checkbox"/>	<input type="checkbox"/>
0.4	VCGT-110304-FN-X8	<input type="checkbox"/>	<input type="checkbox"/>	<input type="checkbox"/>	<input type="checkbox"/>	<input type="checkbox"/>	<input type="checkbox"/>	<input type="checkbox"/>
		<input type="checkbox"/>	<input type="checkbox"/>	<input type="checkbox"/>	<input type="checkbox"/>	<input type="checkbox"/>	<input type="checkbox"/>	<input type="checkbox"/>
0.05	VCGT-1303005-FN-X8	<input type="checkbox"/>	<input type="checkbox"/>	<input type="checkbox"/>	<input type="checkbox"/>	<input type="checkbox"/>	<input type="checkbox"/>	<input type="checkbox"/>
0.1	VCGT-130301-FN-X8	<input type="checkbox"/>	<input type="checkbox"/>	<input type="checkbox"/>	<input type="checkbox"/>	<input type="checkbox"/>	<input type="checkbox"/>	<input type="checkbox"/>
0.2	VCGT-130302-FN-X8	<input type="checkbox"/>	<input type="checkbox"/>	<input type="checkbox"/>	<input type="checkbox"/>	<input type="checkbox"/>	<input type="checkbox"/>	<input type="checkbox"/>
0.4	VCGT-130304-FN-X8	<input type="checkbox"/>	<input type="checkbox"/>	<input type="checkbox"/>	<input type="checkbox"/>	<input type="checkbox"/>	<input type="checkbox"/>	<input type="checkbox"/>
		<input type="checkbox"/>	<input type="checkbox"/>	<input type="checkbox"/>	<input type="checkbox"/>	<input type="checkbox"/>	<input type="checkbox"/>	<input type="checkbox"/>
0.05	VCGT-1604005-FN-X8	<input type="checkbox"/>	<input type="checkbox"/>	<input type="checkbox"/>	<input type="checkbox"/>	<input type="checkbox"/>	<input type="checkbox"/>	<input type="checkbox"/>
0.1	VCGT-160401-FN-X8	<input type="checkbox"/>	<input type="checkbox"/>	<input type="checkbox"/>	<input type="checkbox"/>	<input type="checkbox"/>	<input type="checkbox"/>	<input type="checkbox"/>
0.2	VCGT-160402-FN-X8	<input type="checkbox"/>	<input type="checkbox"/>	<input type="checkbox"/>	<input type="checkbox"/>	<input type="checkbox"/>	<input type="checkbox"/>	<input type="checkbox"/>
0.4	VCGT-160404-FN-X8	<input type="checkbox"/>	<input type="checkbox"/>	<input type="checkbox"/>	<input type="checkbox"/>	<input type="checkbox"/>	<input type="checkbox"/>	<input type="checkbox"/>

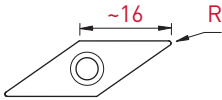
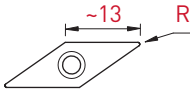
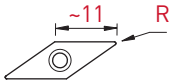

### VCGT-ENP-X8

R	Art. N°	PVD		non revêtu unbeschichtet uncoated
		TiAlN	TiN	K20
		<input type="checkbox"/>	<input type="checkbox"/>	<input type="checkbox"/>
		<input type="checkbox"/>	<input type="checkbox"/>	<input type="checkbox"/>
		<input type="checkbox"/>	<input type="checkbox"/>	<input checked="" type="checkbox"/>
		<input type="checkbox"/>	<input type="checkbox"/>	<input type="checkbox"/>
		<input type="checkbox"/>	<input type="checkbox"/>	<input type="checkbox"/>
0.05	VCGT-1103005-ENP-X8	<input type="checkbox"/>	<input type="checkbox"/>	<input type="checkbox"/>
0.08	VCGT-1103008-ENP-X8	<input type="checkbox"/>	<input type="checkbox"/>	<input type="checkbox"/>
0.1	VCGT-110301-ENP-X8	<input type="checkbox"/>	<input type="checkbox"/>	<input type="checkbox"/>
0.15	VCGT-1103015-ENP-X8	<input type="checkbox"/>	<input type="checkbox"/>	<input type="checkbox"/>
0.2	VCGT-110302-ENP-X8	<input type="checkbox"/>	<input type="checkbox"/>	<input type="checkbox"/>
0.4	VCGT-110304-ENP-X8	<input type="checkbox"/>	<input type="checkbox"/>	<input type="checkbox"/>
		<input type="checkbox"/>	<input type="checkbox"/>	<input type="checkbox"/>
0.05	VCGT-1303005-ENP-X8	<input type="checkbox"/>	<input type="checkbox"/>	<input type="checkbox"/>
0.1	VCGT-130301-ENP-X8	<input type="checkbox"/>	<input type="checkbox"/>	<input type="checkbox"/>
0.2	VCGT-130302-ENP-X8	<input type="checkbox"/>	<input type="checkbox"/>	<input type="checkbox"/>
0.4	VCGT-130304-ENP-X8	<input type="checkbox"/>	<input type="checkbox"/>	<input type="checkbox"/>
		<input type="checkbox"/>	<input type="checkbox"/>	<input type="checkbox"/>
0.05	VCGT-1604005-ENP-X8	<input type="checkbox"/>	<input type="checkbox"/>	<input type="checkbox"/>
0.1	VCGT-160401-ENP-X8	<input type="checkbox"/>	<input type="checkbox"/>	<input type="checkbox"/>
0.2	VCGT-160402-ENP-X8	<input type="checkbox"/>	<input type="checkbox"/>	<input type="checkbox"/>
0.4	VCGT-160404-ENP-X8	<input type="checkbox"/>	<input type="checkbox"/>	<input type="checkbox"/>

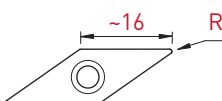
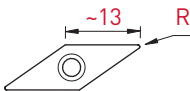
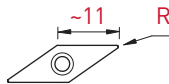

Plaquettes en métal dur  
VHM-Wendeplatten  
Solid carbide inserts

35°

VCGT-X17



VCGT  
FN-X17

R	Art. N°	PVD				non revêtu unbeschichtet uncoated	
		TiAlN	HTA	HTAX	TiN	K10	K20
		<input type="checkbox"/>	<input type="checkbox"/>	<input type="checkbox"/>	<input type="checkbox"/>	<input type="checkbox"/>	<input type="checkbox"/>
0.05	VCGT-1103005-FN-X17	<input checked="" type="checkbox"/>	<input checked="" type="checkbox"/>	<input checked="" type="checkbox"/>	<input checked="" type="checkbox"/>	<input checked="" type="checkbox"/>	<input checked="" type="checkbox"/>
0.08	VCGT-1103008-FN-X17	<input checked="" type="checkbox"/>	<input checked="" type="checkbox"/>	<input checked="" type="checkbox"/>	<input checked="" type="checkbox"/>	<input checked="" type="checkbox"/>	<input checked="" type="checkbox"/>
0.1	VCGT-110301-FN-X17	<input checked="" type="checkbox"/>	<input checked="" type="checkbox"/>	<input checked="" type="checkbox"/>	<input checked="" type="checkbox"/>	<input checked="" type="checkbox"/>	<input checked="" type="checkbox"/>
0.15	VCGT-1103015-FN-X17	<input checked="" type="checkbox"/>	<input checked="" type="checkbox"/>	<input checked="" type="checkbox"/>	<input checked="" type="checkbox"/>	<input checked="" type="checkbox"/>	<input checked="" type="checkbox"/>
0.2	VCGT-110302-FN-X17	<input checked="" type="checkbox"/>	<input checked="" type="checkbox"/>	<input checked="" type="checkbox"/>	<input checked="" type="checkbox"/>	<input checked="" type="checkbox"/>	<input checked="" type="checkbox"/>
0.4	VCGT-110304-FN-X17	<input checked="" type="checkbox"/>	<input checked="" type="checkbox"/>	<input checked="" type="checkbox"/>	<input checked="" type="checkbox"/>	<input checked="" type="checkbox"/>	<input checked="" type="checkbox"/>
0.05	VCGT-1303005-FN-X17	<input checked="" type="checkbox"/>	<input checked="" type="checkbox"/>	<input checked="" type="checkbox"/>	<input checked="" type="checkbox"/>	<input checked="" type="checkbox"/>	<input checked="" type="checkbox"/>
0.1	VCGT-130301-FN-X17	<input checked="" type="checkbox"/>	<input checked="" type="checkbox"/>	<input checked="" type="checkbox"/>	<input checked="" type="checkbox"/>	<input checked="" type="checkbox"/>	<input checked="" type="checkbox"/>
0.2	VCGT-130302-FN-X17	<input checked="" type="checkbox"/>	<input checked="" type="checkbox"/>	<input checked="" type="checkbox"/>	<input checked="" type="checkbox"/>	<input checked="" type="checkbox"/>	<input checked="" type="checkbox"/>
0.4	VCGT-130304-FN-X17	<input checked="" type="checkbox"/>	<input checked="" type="checkbox"/>	<input checked="" type="checkbox"/>	<input checked="" type="checkbox"/>	<input checked="" type="checkbox"/>	<input checked="" type="checkbox"/>
0.05	VCGT-1604005-FN-X17	<input checked="" type="checkbox"/>	<input checked="" type="checkbox"/>	<input checked="" type="checkbox"/>	<input checked="" type="checkbox"/>	<input checked="" type="checkbox"/>	<input checked="" type="checkbox"/>
0.1	VCGT-160401-FN-X17	<input checked="" type="checkbox"/>	<input checked="" type="checkbox"/>	<input checked="" type="checkbox"/>	<input checked="" type="checkbox"/>	<input checked="" type="checkbox"/>	<input checked="" type="checkbox"/>
0.2	VCGT-160402-FN-X17	<input checked="" type="checkbox"/>	<input checked="" type="checkbox"/>	<input checked="" type="checkbox"/>	<input checked="" type="checkbox"/>	<input checked="" type="checkbox"/>	<input checked="" type="checkbox"/>
0.4	VCGT-160404-FN-X17	<input checked="" type="checkbox"/>	<input checked="" type="checkbox"/>	<input checked="" type="checkbox"/>	<input checked="" type="checkbox"/>	<input checked="" type="checkbox"/>	<input checked="" type="checkbox"/>
0.8	VCGT-160408-FN-X17	<input checked="" type="checkbox"/>	<input checked="" type="checkbox"/>	<input checked="" type="checkbox"/>	<input checked="" type="checkbox"/>	<input checked="" type="checkbox"/>	<input checked="" type="checkbox"/>

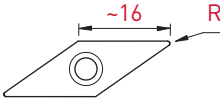
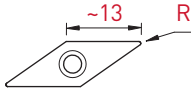
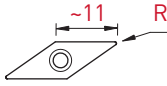

VCGT  
ENP-X17

R	Art. N°	PVD		non revêtu unbeschichtet uncoated
		TiAlN	TiN	K20
		<input type="checkbox"/>	<input type="checkbox"/>	<input type="checkbox"/>
0.05	VCGT-1103005-ENP-X17	<input checked="" type="checkbox"/>	<input checked="" type="checkbox"/>	<input checked="" type="checkbox"/>
0.08	VCGT-1103008-ENP-X17	<input checked="" type="checkbox"/>	<input checked="" type="checkbox"/>	<input checked="" type="checkbox"/>
0.1	VCGT-110301-ENP-X17	<input checked="" type="checkbox"/>	<input checked="" type="checkbox"/>	<input checked="" type="checkbox"/>
0.15	VCGT-1103015-ENP-X17	<input checked="" type="checkbox"/>	<input checked="" type="checkbox"/>	<input checked="" type="checkbox"/>
0.2	VCGT-110302-ENP-X17	<input checked="" type="checkbox"/>	<input checked="" type="checkbox"/>	<input checked="" type="checkbox"/>
0.4	VCGT-110304-ENP-X17	<input checked="" type="checkbox"/>	<input checked="" type="checkbox"/>	<input checked="" type="checkbox"/>
0.05	VCGT-1303005-ENP-X17	<input checked="" type="checkbox"/>	<input checked="" type="checkbox"/>	<input checked="" type="checkbox"/>
0.1	VCGT-130301-ENP-X17	<input checked="" type="checkbox"/>	<input checked="" type="checkbox"/>	<input checked="" type="checkbox"/>
0.2	VCGT-130302-ENP-X17	<input checked="" type="checkbox"/>	<input checked="" type="checkbox"/>	<input checked="" type="checkbox"/>
0.4	VCGT-130304-ENP-X17	<input checked="" type="checkbox"/>	<input checked="" type="checkbox"/>	<input checked="" type="checkbox"/>
0.05	VCGT-1604005-ENP-X17	<input checked="" type="checkbox"/>	<input checked="" type="checkbox"/>	<input checked="" type="checkbox"/>
0.1	VCGT-160401-ENP-X17	<input checked="" type="checkbox"/>	<input checked="" type="checkbox"/>	<input checked="" type="checkbox"/>
0.2	VCGT-160402-ENP-X17	<input checked="" type="checkbox"/>	<input checked="" type="checkbox"/>	<input checked="" type="checkbox"/>
0.4	VCGT-160404-ENP-X17	<input checked="" type="checkbox"/>	<input checked="" type="checkbox"/>	<input checked="" type="checkbox"/>
0.8	VCGT-160408-ENP-X17	<input checked="" type="checkbox"/>	<input checked="" type="checkbox"/>	<input checked="" type="checkbox"/>

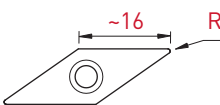
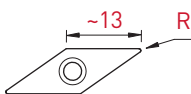
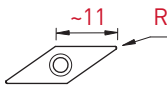





Plaquettes en métal dur

VHM-Wendeplatten

Solid carbide inserts

35°

VCGT-X20



VCGT  
ENP-X20

PVD	
<input type="checkbox"/>	<input type="checkbox"/>
<input checked="" type="checkbox"/> M	<input checked="" type="checkbox"/> M
<input checked="" type="checkbox"/> N	<input checked="" type="checkbox"/> N
<input checked="" type="checkbox"/> S	<input checked="" type="checkbox"/> S
ZTA	HTIX

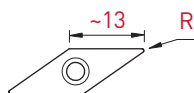

R	H	Art. N°	ZTA	HTIX
0.2	0.25	VCGT-130302-ENP-X20	■	■
0.4	0.25	VCGT-130304-ENP-X20	■	■
0.8	0.25	VCGT-130308-ENP-X20	■	■

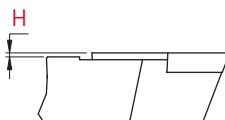

# ISO-LINE

Plaquettes en métal dur  
 VHM-Wendeplatten  
 Solid carbide inserts

35°

VCMT-XF3  
 VCMT-XF2



VCMT  
 EN-XF3

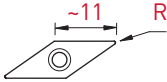

R	Art. N°	PVD	
		TAC	HTAC
0.2	VCMT-110302-EN-XF3	■	■
0.4	VCMT-110304-EN-XF3	■	■

PVD	
P	P
M	M
N	N
S	S
TAC	HTAC



VCMT  
 EN-XF2

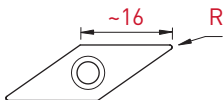
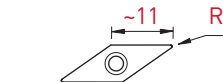

R	Art. N°	PVD		CVD
		TAC	HTAC	HTi5
0.2	VCMT-110302-EN-XF2	■	■	■
0.4	VCMT-110304-EN-XF2	■	■	■
0.4	VCMT-160404-EN-XF2	■	■	■

PVD		CVD
P	P	P
M	M	M
N	N	
S	S	
TAC	HTAC	HTi5

Plaquettes en métal dur

VHM-Wendeplatten

Solid carbide inserts

35°

VCMT-MF

VCMT-HF



VCMT  
EN-MF

R	Art. N°	PVD	CVD
		<input checked="" type="checkbox"/> P <input checked="" type="checkbox"/> M <input type="checkbox"/> <input type="checkbox"/> Tmax	<input checked="" type="checkbox"/> P <input checked="" type="checkbox"/> M <input type="checkbox"/> <input type="checkbox"/> Ti4
0.2	VCMT-110302-EN-MF	■	■
0.4	VCMT-110304-EN-MF	■	■
0.4	VCMT-160404-EN-MF	■	■

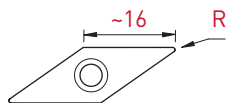
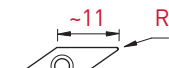

VCMT  
EN-HF

R	Art. N°	PVD	CVD
		<input checked="" type="checkbox"/> P <input checked="" type="checkbox"/> M <input type="checkbox"/> <input type="checkbox"/> Tmax	<input checked="" type="checkbox"/> P <input checked="" type="checkbox"/> M <input type="checkbox"/> <input type="checkbox"/> Ti4
0.4	VCMT-110304-EN-HF	■	■
0.8	VCMT-110308-EN-HF	■	■
0.4	VCMT-160404-EN-HF	■	■
0.8	VCMT-160408-EN-HF	■	■

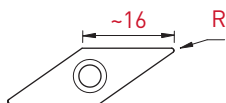
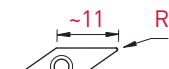



VCGT  
FN-X8



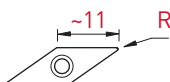

		CERMET	
		PVD	non revêtu unbeschichtet uncoated
		<input checked="" type="checkbox"/> P <input checked="" type="checkbox"/> M <input type="checkbox"/> <input type="checkbox"/>	<input checked="" type="checkbox"/> P <input type="checkbox"/> <input type="checkbox"/> <input type="checkbox"/>
R	Art. N°	CTA	CN6
0.05	VCGT-1103005-FN-X8	<input checked="" type="checkbox"/>	<input checked="" type="checkbox"/>
0.1	VCGT-110301-FN-X8	<input checked="" type="checkbox"/>	<input checked="" type="checkbox"/>
0.2	VCGT-110302-FN-X8	<input checked="" type="checkbox"/>	<input checked="" type="checkbox"/>
0.4	VCGT-110304-FN-X8	<input checked="" type="checkbox"/>	<input checked="" type="checkbox"/>







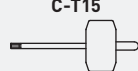

Pièces de rechange et accessoires

Ersatzteile und Zubehör

Spare parts and accessories

<p>Vis et clés de rechange Ersatzschrauben und Schlüssel Spare screws and keys</p>	<p>Porte-outils Halter Holders</p>	<p>Vis Schrauben Screw</p>	<p>Clé Schlüssel Key</p>			
				Option	Serrage Drehmoment Torque	
	<p>Series SC...-06 Series SD...-07 Series SV...-11</p>	<p>V-M2.5X7.8-T8</p> 			SET-NM-TX8	1.3 Nm
	<p>Series SV...-13</p>	<p>V-M3X7.3-T8-ISO</p> 		<p>C-T8</p> 		2.0 Nm
	<p>Series SC...-09 Series SD...-11 Series SV...-16</p>	<p>V-M4X9-T15-ISO</p> 		<p>C-T15</p> 	SET-NM-TX15	3.0 Nm

<p>Pièces de rechange JET Ersatzteile JET Spare parts JET</p>	<p><b>L</b> Pour réf. For ref. Für Ref</p>	 *	 *	 *
		Art. N°	Art. N°	Art. N°
	S...L-10...-JET	JJL-4X12-D1.5		
	S...L-12...-JET S...L-12.7...-JET	JJL-4X14-D1.5	J-M8X1-D6	JB-M8X1
	S...L-16...-JET S...L-20...-JET	JJL-4X17-D1.5		
	<p><b>R</b> Pour réf. For ref. Für Ref</p>	 *	 *	 *
		Art. N°	Art. N°	Art. N°
	S...R-10...-JET	JJR-4X12-D1.5		
	S...R-12...-JET S...R-12.7...-JET	JJR-4X14-D1.5	J-M8X1-D6	JB-M8X1
	S...R-16...-JET S...R-20...-JET	JJR-4X17-D1.5		

\* livré avec chaque porte-outil  
mit jedem Halter geliefert  
delivered with each holder

## Paramètres de coupe indicatifs

## Empfohlene Schnittwerte

## Standard machining data

ISO-Line	Tough grade, for normal to difficult machining conditions	Wear resistant grade, for finishing and light machining	Acier Stahl Steel						Inox Rostfreistahl Stainless steel			
			Acier de décolletage Automatenstahl Free-cutting steel		Acier faiblement allié Leicht legierter Stahl Low alloyed steel		Acier fortement allié Hochlegierter Stahl High alloyed steel		Austénitique Austenitisch Austenitic		Martensitique Martensitisch Martensitic	
			VC (m/min)	F (mm/U)	VC (m/min)	F (mm/U)	VC (m/min)	F (mm/U)	VC (m/min)	F (mm/U)	VC (m/min)	F (mm/U)
FN-X8	TiAlN	HTA	80-180	0.01-0.12	60-150	0.01-0.10	50-120	0.01-0.08	60-140	0.01-0.12	60-140	0.01-0.12
	TiAlX	HTAX	80-180	0.01-0.12	60-150	0.01-0.10	50-120	0.01-0.08	60-140	0.01-0.12	60-140	0.01-0.12
	TiN		80-170	0.01-0.12	60-140	0.01-0.10			60-120	0.01-0.12	60-120	0.01-0.12
	N	HN										
ENP-X8	TiAlN	HTA	80-180	0.03-0.15	60-160	0.03-0.12	50-120	0.03-0.10	60-140	0.03-0.12	60-140	0.03-0.15
	TiN		80-170	0.03-0.15	60-150	0.03-0.12			60-120	0.03-0.12	60-120	0.03-0.15
	N	HN										
FN-X17	TiAlN	HTA	80-180	0.01-0.12	60-150	0.01-0.10			60-140	0.01-0.15	60-140	0.01-0.15
	TiAlX	HTAX	80-180	0.01-0.12	60-150	0.01-0.10	50-120	0.01-0.08	60-140	0.01-0.12	60-140	0.01-0.12
	TiN		80-170	0.01-0.12					60-120	0.01-0.15	60-120	0.01-0.15
	N	HN										
ENP-X17	TiAlN	HTA	80-180	0.03-0.15	60-160	0.03-0.12	50-120	0.03-0.10	60-140	0.03-0.15	60-140	0.03-0.18
	TiAlX	HTAX	80-180	0.01-0.12	60-150	0.01-0.10	50-120	0.01-0.08	60-140	0.01-0.12	60-140	0.01-0.12
	TiN		80-170	0.03-0.15	60-150	0.03-0.12			60-120	0.01-0.15	60-120	0.03-0.18
	N	HN										
FN-X25	TiAlN	HTA							60-140	0.01-0.12		
	TiN								60-120	0.01-0.12		
	N	HN										
ENP-X25	TiAlN	HTA							60-140	0.03-0.12	60-140	0.03-0.15
	TiAlX		80-180	0.01-0.12	60-150	0.01-0.10	50-120	0.01-0.08	60-140	0.01-0.12	60-140	0.01-0.12
	TiN								60-120	0.03-0.12	60-120	0.03-0.15
	N	HN										
ENP-X20	ZTA								60-140	0.03-0.18	60-140	0.03-0.18
	HTiX								60-140	0.03-0.18	60-140	0.03-0.18

G tolerance class		Special 35° VC...11										
FL / FR-X10	TiAlN	HTA	80-180	0.01-0.12	60-150	0.01-0.10	50-120	0.01-0.08	60-140	0.01-0.12	60-140	0.01-0.12
	TiAlX	HTAX	80-180	0.01-0.12	60-150	0.01-0.10	50-120	0.01-0.08	60-140	0.01-0.12	60-140	0.01-0.12
	TiN		80-170	0.01-0.12	60-140	0.01-0.10			60-120	0.01-0.12	60-120	0.01-0.12
	N	HN										
ELP/ERP-X10	TiAlN	HTA	80-180	0.03-0.15	60-160	0.03-0.12	50-120	0.03-0.10	60-140	0.03-0.12	60-140	0.03-0.15
	TiAlX	HTAX	80-180	0.03-0.15	60-160	0.03-0.12	50-120	0.03-0.10	60-140	0.03-0.12	60-140	0.03-0.15
	TiN		80-170	0.03-0.15	60-150	0.03-0.12			60-120	0.03-0.12	60-120	0.03-0.15
	N	HN										
FN-K18		HTA	80-180	0.01-0.10	60-150	0.01-0.10			60-140	0.01-0.10	60-140	0.01-0.10
		HTiN	80-170	0.01-0.10	60-140	0.01-0.10			60-120	0.01-0.10	60-120	0.01-0.10
		HN										
FN-0		HTA	80-150	0.01-0.10								
		HTiN	80-140	0.01-0.10								
		HN										



N Alliage d'aluminium et non ferreux Aluminium- und Nichteisenlegierungen Aluminium and non-ferrous alloys								S Titane et superalliages Titan und Superlegierungen Titanium and superalloys					
Aluminium		Al-Si		Cuivre Kupfer Copper		Laiton & bronze Messing & Bronze Brass & bronze		Ti grade 1 - 3		Ti grade 4 - 6		Superalliages Superlegierungen Superalloys	
VC (m/min)	F (mm/U)	VC (m/min)	F (mm/U)	VC (m/min)	F (mm/U)	VC (m/min)	F (mm/U)	VC (m/min)	F (mm/U)	VC (m/min)	F (mm/U)	VC (m/min)	F (mm/U)
		150-1600	0.01-0.15	80-300	0.01-0.12	100-400	0.01-0.15			30-60	0.01-0.12	40-70	0.01-0.10
								30-70	0.01-0.12	30-60	0.01-0.12	40-70	0.01-0.10
120-2200	0.01-0.18	150-1600	0.01-0.15	80-300	0.01-0.12	100-400	0.01-0.15						
120-2000	0.01-0.18	150-1500	0.01-0.15	80-250	0.01-0.12	100-300	0.01-0.15	30-70	0.01-0.12				
		150-800	0.03-0.18	80-300	0.03-0.15					30-60	0.03-0.12	40-70	0.03-0.10
		150-800	0.03-0.18	80-300	0.03-0.15								
		150-800	0.03-0.18	80-250	0.03-0.15								
		150-1600	0.01-0.18	80-300	0.01-0.15	100-400	0.01-0.18			30-70	0.01-0.15	40-80	0.01-0.12
								30-70	0.01-0.12	30-60	0.01-0.12	40-70	0.01-0.10
120-2200	0.01-0.25	150-1600	0.01-0.18	80-300	0.01-0.15	100-400	0.01-0.18						
120-2000	0.01-0.25	150-1500	0.01-0.18	80-250	0.01-0.15	100-300	0.01-0.18	40-80	0.01-0.15				
		150-800	0.03-0.20	80-300	0.03-0.18					30-70	0.03-0.15	40-80	0.03-0.12
								30-70	0.01-0.12	30-60	0.01-0.12	40-70	0.01-0.10
		150-800	0.03-0.20	80-300	0.03-0.18								
		150-800	0.03-0.20	80-250	0.03-0.18								
		150-1600	0.01-0.22	80-300	0.01-0.18					30-60	0.01-0.12	40-70	0.01-0.10
120-2200	0.01-0.30	150-1600	0.01-0.22	80-300	0.01-0.18								
120-2000	0.01-0.30	150-1500	0.01-0.22	80-250	0.01-0.18			30-70	0.01-0.12				
		150-800	0.03-0.25	80-300	0.03-0.20					30-60	0.03-0.12	40-70	0.03-0.10
								30-70	0.01-0.12	30-60	0.01-0.12	40-70	0.01-0.10
		150-800	0.03-0.25	80-300	0.03-0.20								
		150-800	0.03-0.25	80-250	0.03-0.20								
		150-800	0.03-0.25	80-300	0.03-0.20					40-90	0.03-0.15	40-100	0.03-0.15
		150-800	0.03-0.25	80-300	0.03-0.20					40-80	0.03-0.15	40-90	0.03-0.15

		150-1600	0.01-0.18	80-300	0.01-0.15	100-400	0.01-0.18			30-60	0.01-0.12	40-70	0.01-0.10
								30-70	0.01-0.12	30-60	0.01-0.12	40-70	0.01-0.10
120-2200	0.01-0.20	150-1600	0.01-0.18	80-300	0.01-0.15	100-400	0.01-0.18						
120-2000	0.01-0.20	150-1500	0.01-0.18	80-250	0.01-0.15	100-300	0.01-0.18	30-70	0.01-0.12				
		150-1600	0.03-0.20	80-300	0.03-0.18					30-60	0.03-0.12	40-70	0.03-0.10
										30-60	0.03-0.12	40-70	0.03-0.10
		150-1600	0.03-0.20	80-300	0.01-0.18								
		150-1500	0.03-0.20	80-250	0.01-0.18								
		150-1600	0.01-0.12	80-300	0.01-0.10					30-70	0.01-0.10	40-80	0.01-0.10
120-2200	0.01-0.15	150-1600	0.01-0.12	80-300	0.01-0.10								
120-2000	0.01-0.15	150-1500	0.01-0.12	80-250	0.01-0.10			40-80	0.01-0.10				
						100-400	0.01-0.18						
						100-400	0.01-0.18						
						100-300	0.01-0.18						

## Paramètres de coupe indicatifs

## Empfohlene Schnittwerte

## Standard machining data

ISO-Line M tolerance class	Tough grade, for normal to difficult machining conditions	Wear resistant grade, for finishing and light machining	Acier Stahl Steel						Inox Rostfreistahl Stainless steel			
			Acier de décolletage Automatenstahl Free-cutting steel		Acier faiblement allié Leicht legierter Stahl Low alloyed steel		Acier fortement allié Hochlegierter Stahl High alloyed steel		Austénitique Austenitisch Austenitic		Martensitique Martensitisch Martensitic	
			VC (m/min)	F (mm/U)	VC (m/min)	F (mm/U)	VC (m/min)	F (mm/U)	VC (m/min)	F (mm/U)	VC (m/min)	F (mm/U)
EN-XF3	TAC	HTAC	100-200	0.03-0.15	80-160	0.03-0.12	50-120	0.03-0.10	60-140	0.03-0.12	60-140	0.03-0.15
EN-XF2	TAC	HTAC	100-200	0.03-0.15	80-160	0.03-0.12	50-120	0.03-0.10	60-140	0.03-0.12	60-140	0.03-0.15
		HTi5	100-250	0.03-0.15	80-220	0.03-0.12	50-180	0.03-0.10	80-200	0.03-0.12	80-200	0.03-0.15
EN-MF2	TAC	HTAC	100-200	0.04-0.15	80-160	0.04-0.12	50-120	0.04-0.10	60-140	0.04-0.12	60-140	0.04-0.15
		HTi5	100-250	0.04-0.15	80-220	0.04-0.12	50-180	0.04-0.10	80-200	0.04-0.12	80-200	0.04-0.15
EN-MF	Tmax		100-220	0.04-0.30	80-180	0.04-0.25	50-150	0.04-0.20	60-150	0.04-0.25	60-150	0.04-0.25
		Ti4	100-250	0.05-0.30	80-220	0.05-0.25	50-180	0.05-0.20	80-200	0.05-0.25	80-200	0.05-0.25
EN-HF3	TiX	HTiX	100-220	0.06-0.35	80-180	0.06-0.30	50-150	0.06-0.25	60-150	0.06-0.25	60-150	0.06-0.25
		Ti6	100-250	0.06-0.35	80-220	0.06-0.30	50-180	0.06-0.25	80-200	0.06-0.25	80-200	0.06-0.25
EN-HF	Tmax		100-220	0.08-0.40	80-180	0.08-0.35	50-150	0.08-0.30	60-150	0.08-0.30	60-150	0.08-0.30
		TAC	100-200	0.08-0.40	80-160	0.08-0.35	50-140	0.08-0.30	60-140	0.08-0.30	60-140	0.08-0.30
		Ti4	100-250	0.08-0.40	80-220	0.08-0.35	50-180	0.08-0.30	80-200	0.08-0.30	80-200	0.08-0.30
		Ti5	HTi5	100-280	0.08-0.40	80-250	0.08-0.35	50-200	0.08-0.30	80-220	0.08-0.30	80-220

ISO-Line CERMET												
FN-X8 CERMET	CTA		100-350	0.01-0.12	80-300	0.01-0.10	70-250	0.01-0.08	80-250	0.01-0.12	80-250	0.01-0.12
		CN6	100-300	0.01-0.12	80-250	0.01-0.10	70-200	0.01-0.08				
ENP-KX CERMET	CT7	HCT7	100-350	0.03-0.20	80-300	0.03-0.18	70-250	0.03-0.15	80-250	0.03-0.18	80-250	0.03-0.18
		CN6	100-300	0.03-0.20	80-250	0.03-0.18	70-200	0.03-0.15				
EN-KM CERMET	CT7	HCT7	100-350	0.03-0.25	80-300	0.03-0.20	70-250	0.03-0.18	80-250	0.03-0.20	80-250	0.03-0.20
		CN6	100-300	0.03-0.25	80-250	0.03-0.20	70-200	0.03-0.18				





N Alliages d'aluminium et non ferreux Aluminium- und Nichteisenlegierungen Aluminium and non-ferrous alloys								S Titane et superalliages Titan und Superlegierungen Titanium and superalloys					
Aluminium		Al-Si		Cuivre Kupfer Copper		Laiton & bronze Messing & Bronze Brass & bronze		Ti grade 1 - 3		Ti grade 4 - 6		Superalliages Superlegierungen Superalloys	
VC (m/min)	F (mm/U)	VC (m/min)	F (mm/U)	VC (m/min)	F (mm/U)	VC (m/min)	F (mm/U)	VC (m/min)	F (mm/U)	VC (m/min)	F (mm/U)	VC (m/min)	F (mm/U)
		120-1500	0.03-0.20	80-300	0.03-0.15	100-400	0.03-0.18			30-70	0.03-0.15	40-80	0.03-0.12
						100-400	0.03-0.18			30-70	0.03-0.15	40-80	0.03-0.12
		120-1500	0.04-0.20	80-300	0.04-0.15	100-400	0.04-0.18			30-70	0.04-0.15	40-80	0.04-0.12
										30-70	0.06-0.20	40-80	0.06-0.20

Conseils d'utilisation

Anwendungsempfehlungen

Application recommendations

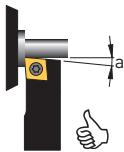

• pour un meilleur état de surface et une meilleure stabilité d'usinage, choisir une géométrie d'outil permettant un angle "a" le plus petit possible

• für bessere Oberflächegüte und Bearbeitungsstabilität, muss die Werkzeuggeometrie mit kleinstmöglichem Winkel "a" ausgewählt werden

• for a better surface finish and better machining stability, choose a tool geometry with angle "a" as small as possible

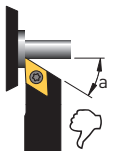

rapport hauteur de passe / rayon d'outil  
Verhältnis zwischen Spantiefe und Werkzeugradius  
machining depth / tool radius ratio

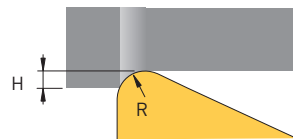

$H_{min} = 0.7 \times R$   
 $R_{max} = 1.4 \times H$

Porte-outils / Halter / Holders

**H**

Système de serrage monobloc  
Einteiliges Klemmsystem  
Monobloc top clamp system

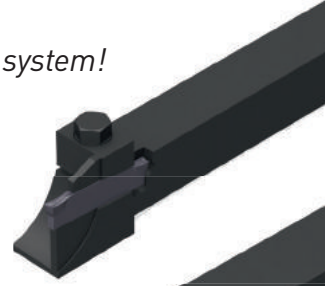

**H JET**

Porte-outils avec arrosage intégré  
Halter mit integrierter Kühlmittelzufuhr  
Holders with integrated coolant supply

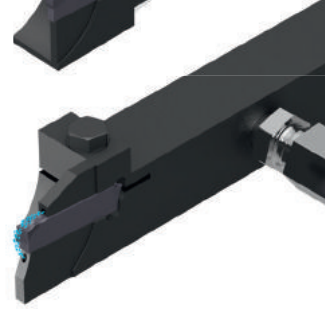

**H-HM-JET**  
**GWS-HM**  
**MS-HM**

Porte-lames avec arrosage  
Halter für Stechklinge mit Kühlung  
Holder for parting-off blades with coolant

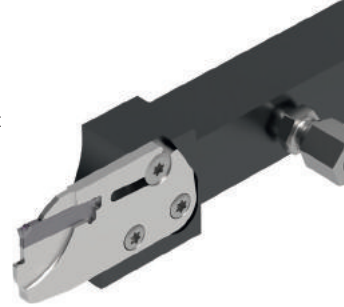

**HM**  
**HK**  
**HUK**

Lames  
Stechklinge  
Parting-off blades

Plaquettes / WSP / Inserts

**ET 15**

=

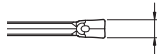

1.5 mm

Ø max 32 mm

**ET 20**

=

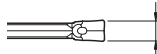

2.0 mm

**ET 25**

=

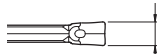

2.5 mm

**ET 30**

=

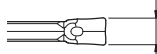

3.0 mm

Ø max 44 mm



**U**

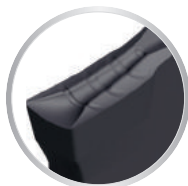

**J**



**T**



**A**

*Very rigid clamping system!*

## Index

Informations techniques  
Technisches Informationen  
Technical information > **8.02**

Géométries de coupe  
Spanformgeometrie  
Cutting geometries > **8.04**

Nuances  
Sorten  
Grades > **8.05**

**H Series** sans arrosage  
ohne Kühlung  
without coolant > **8.06**

**H JET Series** avec arrosage  
mit Kühlung  
with coolant > **8.07**

**H-HM-JET Series** avec arrosage  
mit Kühlung  
with coolant > **8.08** **new**

**GWS Series** Göltenbodt > **8.09** **new**

**MS Series** Index > **8.13** **new**

Lames  
Stecklingen  
Blades **HM-HK-HUK Series** > **8.14**

**U Series** > **8.20**

**J Series** > **8.22**

**T Series** > **8.24**

**A Series** > **8.26**

Paramètres de coupe indicatifs  
Empfohlene Schnittwerte  
Standard machining data > **8.28**

Compact: seulement 20 mm pour les machines courantes

Kompakt: nur 20 mm für übliche Maschinen

Compact: only 20 mm for current machines

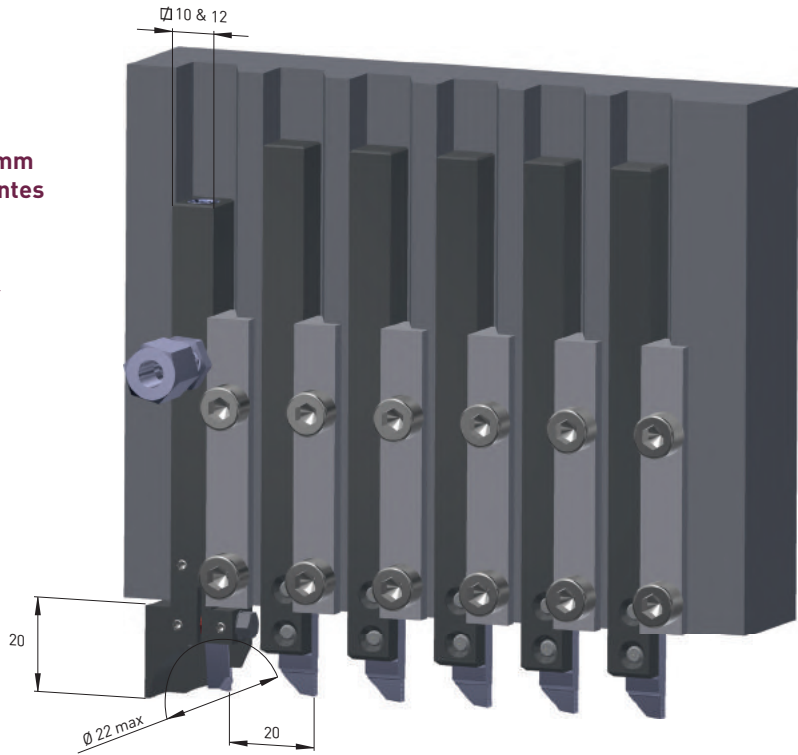

Facilité d'accès

Zugangseichtigkeit

Excellent accessibility

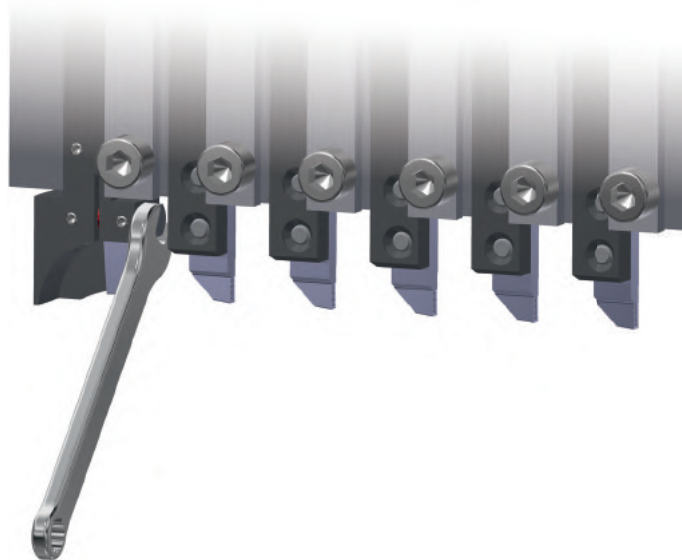

Changement de la plaquelette sans démontage

Veränderung der Platte ohne Zerlegung

Change of insert without disassembly

**Butée de serrage**  
**Spannungs-Anschlag**  
**Clamping stop**

Distance de serrage  
 Anschlagabstand  
 Distance clamping

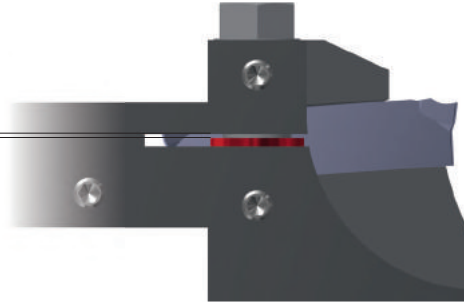

**Recommendations de serrage:**  
 n'utiliser que la clé fournie  
**Spannungsempfehlungen:**  
 nur den gelieferten Schlüssel benutzen  
**Tightening recommendation:**  
 only use the delivered key

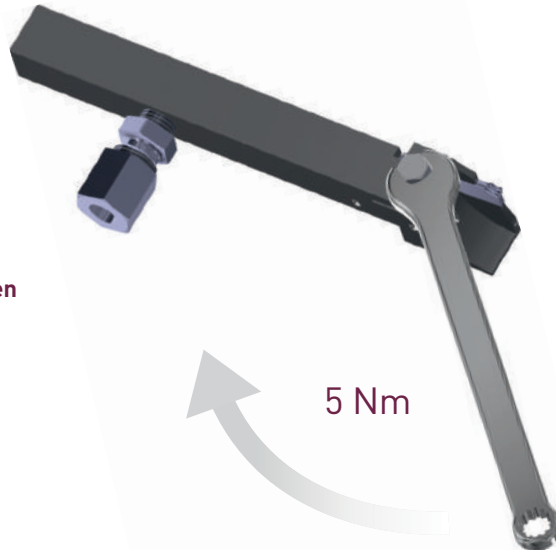

**Support JET à double lubrification**  
**JET Halter mit doppeltem Schmierung**  
**Jet holder with double lubrication**

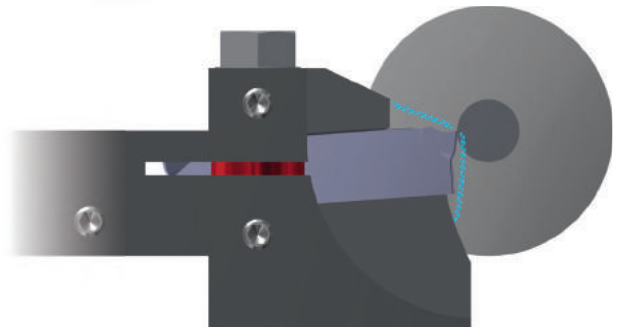

# EVOCUT-LINE

Géométries de coupe

Spanformgeometrie

Cutting geometries

UN

UL  
UR

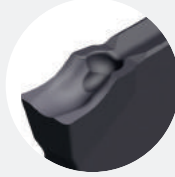

- géométrie positive universelle, faibles efforts de coupe
- bonne maîtrise du copeau
- 1<sup>er</sup> choix pour l'inox

- allgemeine Geometrie, geringe Schnittkräfte
- gute Spankontrolle
- 1. Wahl für rostfreiem Stahl

- all-round geometry, low cutting forces
- efficient chip control
- 1<sup>st</sup> choice for stainless steel

JN

JR

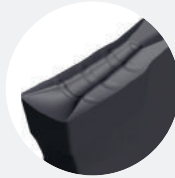

- géométrie universelle
- excellent rétrécissement du copeau pour un meilleur contrôle
- conseillé pour le tronçonnage de pièces à parois minces
- pour acier et inox

- allgemeine Geometrie
- ausgezeichnete Spanversmalerung für eine bessere Spankontrolle
- für abstechen von dünnwandigen Teilen empfohlen
- für Stahl und rostfreiem Stahl

- all-round geometry
- very efficient arrow for a better chip control
- recommended for parting off of thin-walled parts
- for steel and stainless steel

TN

TR



- géométrie négative
- utilisation dans des conditions de rigidité optimale
- pour les matières à haute ténacité
- universel pour les aciers et inox

- negative Geometrie
- bei stabilen Verhältnissen einsetzbar
- für hohe widerstandsfähige Rohstoffe
- allgemein für Stahl und rostfreiem Stahl

- negative geometry
- use in solid cutting conditions
- for high toughness material
- universal for steel and stainless steel

AN

AR



- géométrie fortement positive
- roule-copeau poli avec arêtes de coupe vives
- 1<sup>er</sup> choix pour aluminium et matériaux non ferreux

- stark positive Geometrie
- geschliffene Spanrolle mit scharfe Schneidkanten
- 1. Wahl für Aluminium und Nichteisenmetalle

- very positive geometry
- polished chip roller with sharp cutting edge
- 1<sup>st</sup> choice for aluminium and non-ferrous materials

Nuances

Sorten

Grades

<p><b>P</b> <b>M</b> <b>N</b> <b>S</b></p> <p><b>TiAlN</b> revêtement PVD PVD Beschichtung PVD coating</p>	<p><b>P</b> <b>M</b> <input type="checkbox"/> <input type="checkbox"/></p> <p><b>Tmax</b> revêtement PVD PVD Beschichtung PVD coating</p>	<p><b>P</b> <b>M</b> <input type="checkbox"/> <input type="checkbox"/></p> <p><b>Zmax</b> revêtement PVD PVD Beschichtung PVD coating</p>
<ul style="list-style-type: none"> <li>pour l'usinage des aciers, aciers inoxydables et alliages de titane</li> <li>1<sup>er</sup> choix pour les avances faibles à modérées</li> </ul>	<ul style="list-style-type: none"> <li>nuance pour usinage moyen à lourd des aciers, aciers alliés et inoxydables</li> <li>bonne résistance aux températures d'usinage élevées</li> <li>1<sup>er</sup> choix pour le tronçonnage des aciers au carbone et des aciers fortement alliés</li> </ul>	<ul style="list-style-type: none"> <li>pour l'usinage des aciers, aciers inoxydables et alliages de titane en conditions défavorables</li> <li>bonne résistance aux chocs à des vitesses de coupe moyenne à faible</li> <li>1<sup>er</sup> choix pour le tronçonnage en coupe interrompue</li> </ul>
<ul style="list-style-type: none"> <li>für die Bearbeitung von Stahl, rostfreiem Stahl und Titanlegierungen</li> <li>beste Wahl für niedrige bis mittlere Vorschübe</li> </ul>	<ul style="list-style-type: none"> <li>Sorte für mittlere bis hohe Belastung in Stahl und legierter Stahlbearbeitung</li> <li>gute Bearbeitungswarmfestigkeit</li> <li>für die Bearbeitung von legiertem Kohlenstahl und hoch legiertem Stahl bestens geeignet</li> </ul>	<ul style="list-style-type: none"> <li>für die Bearbeitung von Stahl, rostfreiem Stahl und Titanlegierungen in schwierige Bearbeitungsfälle</li> <li>gute Bruchfestigkeit mit durchschnittliche bis niedrige Schnittgeschwindigkeit</li> <li>für die Bearbeitung in unterbrochenen Schnitte bestens geeignet</li> </ul>
<ul style="list-style-type: none"> <li>for machining of steel, stainless steel and titanium alloys</li> <li>first choice for low to average cutting speed</li> </ul>	<ul style="list-style-type: none"> <li>grade for medium to heavy machining of steel, stainless steel and alloyed steel</li> <li>high machining heat resistance</li> <li>first choice for the machining of carbon steel and high alloyed steel</li> </ul>	<ul style="list-style-type: none"> <li>for machining of steel, stainless steel and titanium alloys in unfavourable machining conditions</li> <li>good impact resistance with average to low cutting speed</li> <li>first choice for machining in interrupted cut</li> </ul>
<p><b>P</b> <b>M</b> <input type="checkbox"/> <input type="checkbox"/></p> <p><b>ZTi6</b> revêtement CVD CVD Beschichtung CVD coating</p>	<p><input type="checkbox"/> <input type="checkbox"/> <b>N</b> <b>S</b></p> <p><b>AS</b> revêtement PVD PVD Beschichtung PVD coating</p>	<p><input type="checkbox"/> <input type="checkbox"/> <b>N</b> <b>S</b></p> <p><b>N</b> non-revêtu unbeschichtet uncoated</p>
<ul style="list-style-type: none"> <li>nuance très tenace</li> <li>grande résistance à la température</li> <li>1<sup>er</sup> choix pour les aciers «haute température»</li> <li>secondairement pour les aciers inox</li> </ul>	<ul style="list-style-type: none"> <li>nuance pour métaux non ferreux</li> <li>très faible coefficient de frottement</li> <li>1<sup>er</sup> choix pour l'usinage des aluminiums jusqu'à 5% Si, des cuivres et titanes faiblement alliés</li> </ul>	<ul style="list-style-type: none"> <li>nuance non revêtu</li> <li>recommandé pour l'usinage des matières non-ferreuses</li> <li>titane, laiton, cuivre, aluminium sans silicium, plastique</li> </ul>
<ul style="list-style-type: none"> <li>sehr zähe Sorte</li> <li>hohe Bearbeitungswarmfestigkeit</li> <li>1. Wahl für „hohe Temperatur“ Stähle</li> <li>sekundär für rostfreie Stähle</li> </ul>	<ul style="list-style-type: none"> <li>Sorte für Nichteisenmetalle</li> <li>sehr geringer Reibwert</li> <li>für die Bearbeitung von Aluminium bis 5% Si, Kupfer und niedriglegiertem Titan bestens geeignet</li> </ul>	<ul style="list-style-type: none"> <li>unbeschichtete Sorte</li> <li>für die Bearbeitung von Nichteisenmetalle empfohlen</li> <li>Titan, Messing, Kupfer, Silicium freies Aluminium, Kunststoff</li> </ul>
<ul style="list-style-type: none"> <li>very strong grade</li> <li>good wear resistance</li> <li>1<sup>st</sup> choice for "high temperature" steels</li> <li>secondarily for stainless steels</li> </ul>	<ul style="list-style-type: none"> <li>grade for non-ferrous materials</li> <li>very low friction ratio</li> <li>first choice for aluminium up to 5% Si, copper and low alloyed titanium</li> </ul>	<ul style="list-style-type: none"> <li>uncoated grade</li> <li>recommended for machining of non-ferrous materials</li> <li>titanium, brass, bronze, aluminium without silicium, plastic</li> </ul>

# EVOCUT-LINE

Porte-outils

Halter

Holders

Ø max 44 mm

H Series

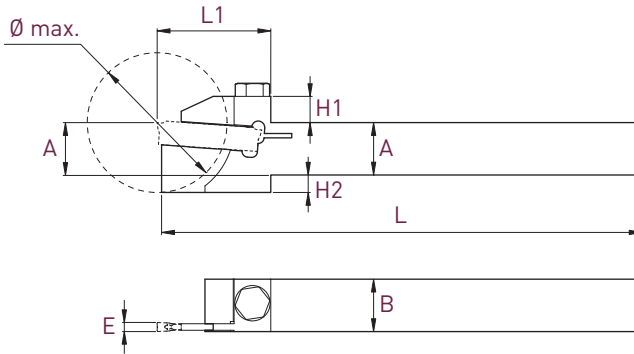

Plaquettes WSP Inserts	A x B	L	Ø max.	L1	H1	H2	Art. N°		Pièces de rechange Ersatzteile Spare parts	
							Art. N°	Art. N°	Art. N°	Art. N°
<b>E</b> 1.5	10x12	110	22	20	5	6	ET15-H1012L-D22	ET15-H1012R-D22	V-M5X20-6P6	C-6PEX-6.0
	12x12	110	22	20	5	4	ET15-H1212L-D22	ET15-H1212R-D22		
	12.7x12.7	110	22	20	5	3	ET15-H12.7L-D22	ET15-H12.7R-D22		
<b>Type</b> ET15	12x12	110	32	26	6	4	ET15-H1212L-D32	ET15-H1212R-D32	V-M5X21-6P7	C-6PEX-7.0
	12.7x12.7	110	32	26	6	3	ET15-H12.7L-D32	ET15-H12.7R-D32		
	16x16	110	32	26	6	-	ET15-H1616L-D32	ET15-H1616R-D32		
<b>E</b> 2.0	10x12	110	22	20	5	6	ET20-H1012L-D22	ET20-H1012R-D22	V-M5X20-6P6	C-6PEX-6.0
	12x12	110	22	20	5	4	ET20-H1212L-D22	ET20-H1212R-D22		
	12.7x12.7	110	22	20	5	3	ET20-H12.7L-D22	ET20-H12.7R-D22		
<b>Type</b> ET20	12x12	110	32	26	6	4	ET20-H1212L-D32	ET20-H1212R-D32	V-M5X21-6P7	C-6PEX-7.0
	12.7x12.7	110	32	26	6	3	ET20-H12.7L-D32	ET20-H12.7R-D32		
	16x16	110	32	26	6	-	ET20-H1616L-D32	ET20-H1616R-D32		
<b>E</b> 2.5	10x12	110	22	20	5	6	ET25-H1012L-D22	ET25-H1012R-D22	V-M5X20-6P6	C-6PEX-6.0
	12x12	110	22	20	5	4	ET25-H1212L-D22	ET25-H1212R-D22		
	12.7x12.7	110	22	20	5	3	ET25-H12.7L-D22	ET25-H12.7R-D22		
<b>Type</b> ET25	12x12	110	32	26	6	4	ET25-H1212L-D32	ET25-H1212R-D32	V-M5X21-6P7	C-6PEX-7.0
	12.7x12.7	110	32	26	6	3	ET25-H12.7L-D32	ET25-H12.7R-D32		
	16x16	110	32	26	6	-	ET25-H1616L-D32	ET25-H1616R-D32		
<b>E</b> 3.0	16x16	130	44	35	8	4	ET30-H1616L-D44	ET30-H1616R-D44	V-M5X27-6P7	C-6PEX-7.0
	20x20	130	44	35	8	-	ET30-H2020L-D44	ET30-H2020R-D44		
	25x25	140	44	35	8	-	ET30-H2525L-D44	ET30-H2525R-D44		
<b>Type</b> ET30	16x16	110	32	26	6	-	ET30-H1616L-D32	ET30-H1616R-D32	V-M5X21-6P7	C-6PEX-7.0
	16x16	130	44	35	8	4	ET30-H1616L-D44	ET30-H1616R-D44		
	20x20	130	44	35	8	-	ET30-H2020L-D44	ET30-H2020R-D44		
<b>Type</b> ET30	20x20	130	44	35	8	-	ET30-H2020L-D44	ET30-H2020R-D44	V-M5X27-6P7	C-6PEX-7.0
	25x25	140	44	35	8	-	ET30-H2525L-D44	ET30-H2525R-D44		

\* livré avec chaque porte-outil  
mit jedem Halter geliefert  
delivered with each holder



Porte-outils avec arrosage intégré

Halter mit integrierter Kühlmittelzufuhr

Holder with integrated coolant supply

Ø max 44 mm

H JET Series

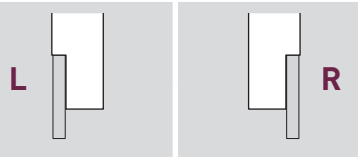
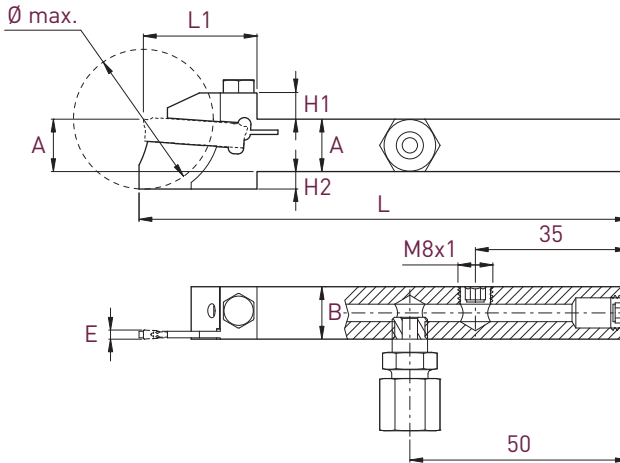

Plaquettes WSP Inserts	A x B	L	Ø max.	L1	H1	H2	Art. N°	
							Art. N°	Art. N°
<b>E</b> 2.0 <b>Type</b> ET20	10x12	110	22	20	5	6	ET20-H1012L-JET22	ET20-H1012R-JET22
	12x12	110	22	20	5	4	ET20-H1212L-JET22	ET20-H1212R-JET22
	12.7x12.7	110	22	20	5	3	ET20-H12.7L-JET22	ET20-H12.7R-JET22
	12x12	110	32	26	6	4	ET20-H1212L-JET32	ET20-H1212R-JET32
	12.7x12.7	110	32	26	6	3	ET20-H12.7L-JET32	ET20-H12.7R-JET32
	16x16	110	32	26	6	6	ET20-H1616L-JET32	ET20-H1616R-JET32
	16x16	130	44	35	8	4	ET20-H1616L-JET44	ET20-H1616R-JET44
20x20	130	44	35	8	-	ET20-H2020L-JET44	ET20-H2020R-JET44	
<b>E</b> 2.5 <b>Type</b> ET25	10x12	110	22	20	5	6	ET25-H1012L-JET22	ET25-H1012R-JET22
	12x12	110	22	20	5	4	ET25-H1212L-JET22	ET25-H1212R-JET22
	12.7x12.7	110	22	20	5	3	ET25-H12.7L-JET22	ET25-H12.7R-JET22
	12x12	110	32	26	6	4	ET25-H1212L-JET32	ET25-H1212R-JET32
	12.7x12.7	110	32	26	6	3	ET25-H12.7L-JET32	ET25-H12.7R-JET32
	16x16	110	32	26	6	6	ET25-H1616L-JET32	ET25-H1616R-JET32
	16x16	130	44	35	8	4	ET25-H1616L-JET44	ET25-H1616R-JET44
20x20	130	44	35	8	-	ET25-H2020L-JET44	ET25-H2020R-JET44	
<b>E</b> 3.0 <b>Type</b> ET30	16x16	110	32	26	6	-	ET30-H1616L-JET32	ET30-H1616R-JET32
	16x16	130	44	35	8	4	ET30-H1616L-JET44	ET30-H1616R-JET44
	20x20	130	44	35	8	-	ET30-H2020L-JET44	ET30-H2020R-JET44
	25x25	140	44	35	8	-	ET30-H2525L-JET44	ET30-H2525R-JET44

Pièces de rechange  
Ersatzteile  
Spare parts



Art. N°	Art. N°
V-M5X20-6P6-J	C-6PEX-6.0
V-M5X21-6P7-J	C-6PEX-7.0
V-M5X27-6P7-J	C-6PEX-7.0
V-M5X20-6P6-J	C-6PEX-6.0
V-M5X21-6P7-J	C-6PEX-7.0
V-M5X27-6P7-J	C-6PEX-7.0
V-M5X21-6P7-J	C-6PEX-7.0
V-M5X27-6P7-J	C-6PEX-7.0

Pièces de rechange  
Ersatzteile  
Spare parts



Art. N°

Art. N°

J-M8X1-D6

JB-M8X1

\* Livré avec chaque porte-outil  
mit jedem Halter geliefert  
delivered with each holder

# EVOCUT-LINE

Porte-lames avec arrosage

Halter für Stechklinge mit Kühlung

Holder for parting-off blades with coolant

## H-HM-JET Series

**new**

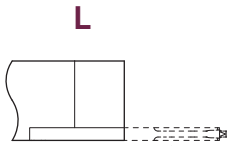
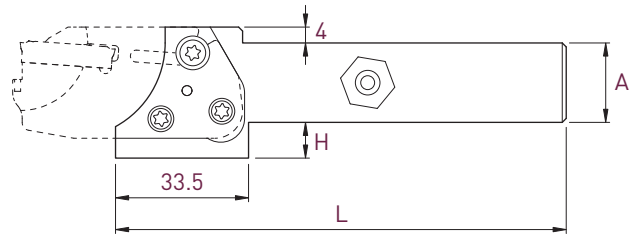



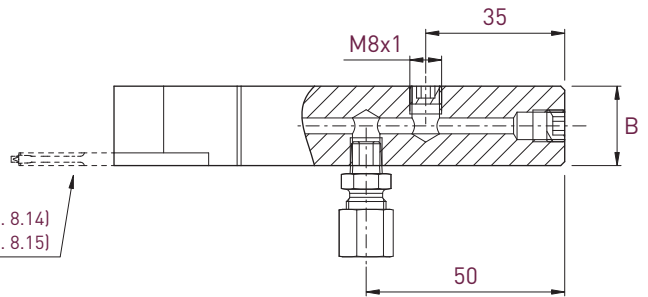

HM-IN (p. 8.14)  
HM-IL-JET (p. 8.15)

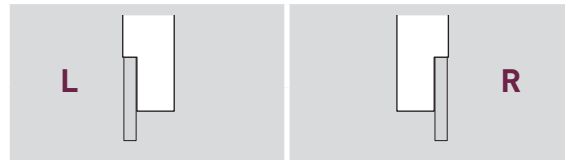

HM-IN (p. 8.14)  
HM-IR-JET (p. 8.15)





A x B	L	H	Art. N°	Art. N°
16x16	113.5	13	H1616L-HM-JET	H1616R-HM-JET
20x20	113.5	9	H2020L-HM-JET	H2020R-HM-JET
25x25	138.5	4	H2525L-HM-JET	H2525R-HM-JET

Pièces de rechange Ersatzteile Spare parts					
	Art. N°	Art. N°	Art. N°	Art. N°	Art. N°
	V-M5X10-T20IP	V-M6X10-T20IP	J-M8X1-D6	JB-M8X1	C-T20IP

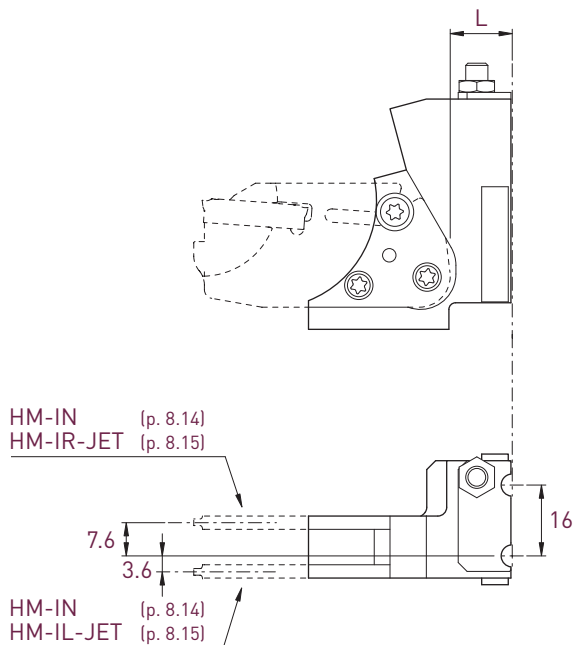
**new**

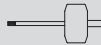

Pièces de rechange  
Ersatzteile  
Spare parts

Interface	Machine compatibility	L	Art. N°	Pièces de rechange Ersatzteile Spare parts		
				Art. N°	Art. N°	Art. N°
GWS02	AS14	14	GWS02R-02001-HM-JET			
	SAS16					
	SBS20					
	Others	22	GWS02R-02002-HM-JET			

**new**

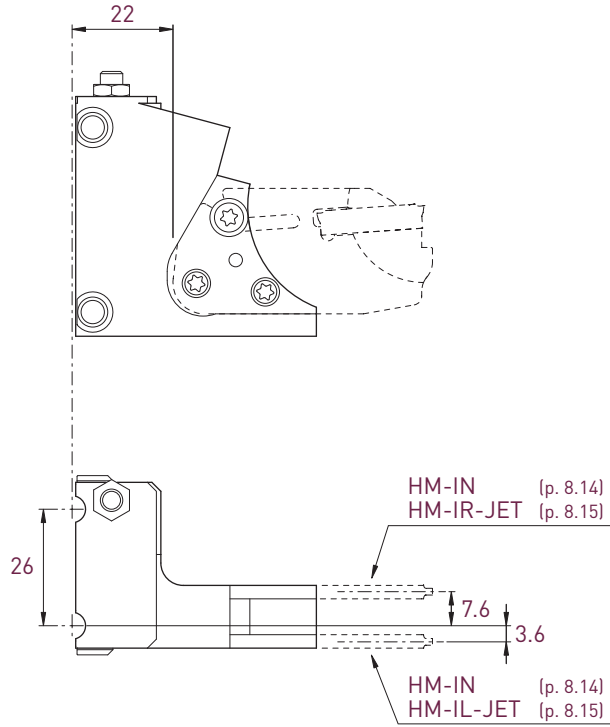

Pièces de rechange  
Ersatzteile  
Spare parts

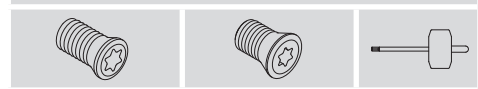

Interface	Machine compatibility	Art. N°	Art. N°	Art. N°	Art. N°
<b>GWS41</b>	MultiSwiss 6X16	<b>GWS41L-41001-HM-JET</b>	<b>V-M5X10-T20IP</b>	<b>V-M6X10-T20IP</b>	<b>C-T20IP</b>
	MultiDeco 20X6				
	MultiDeco 20X8				
	MultiDeco 26X6				
	MultiDeco 32X6				
	MultiAlpha 20X8				
	MultiSigma 24X8				

**new**

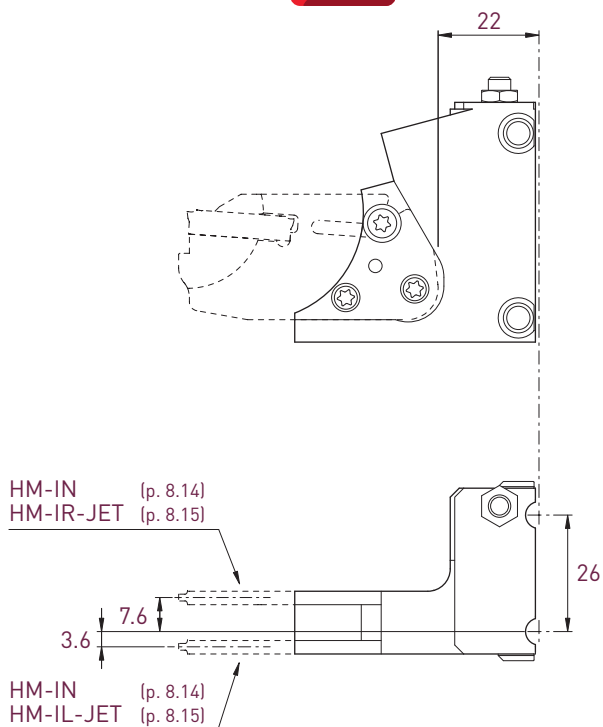



Pièces de rechange  
Ersatzteile  
Spare parts

Interface	Machine compatibility	Art. N°	Pièces de rechange Ersatzteile Spare parts		
			Art. N°	Art. N°	Art. N°
GWS41	MultiSwiss 6X16	GWS41R-41001-HM-JET	V-M5X10-T20IP	V-M6X10-T20IP	C-T20IP
	MultiDeco 20X6				
	MultiDeco 20X8				
	MultiDeco 26X6				
	MultiDeco 32X6				
	MultiAlpha 20X8				
	MultiSigma 24X8				

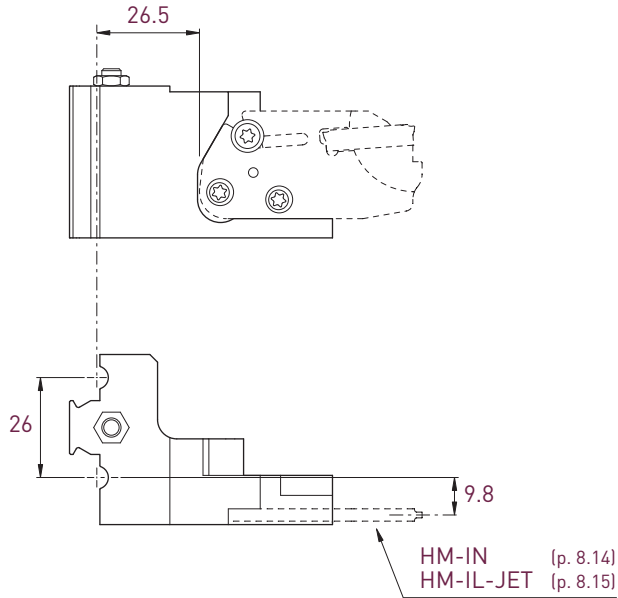
**new**

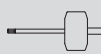

		Pièces de rechange Ersatzteile Spare parts				
						
Interface	Machine compatibility	Art. N°	Art. N°	Art. N°	Art. N°	
GWS202	MultiSwiss 6X32	GWS202L-202001-HM-JET	V-M5X10-T20IP	V-M6X10-T20IP	C-T20IP	
	MultiSwiss 8X26					

**new**

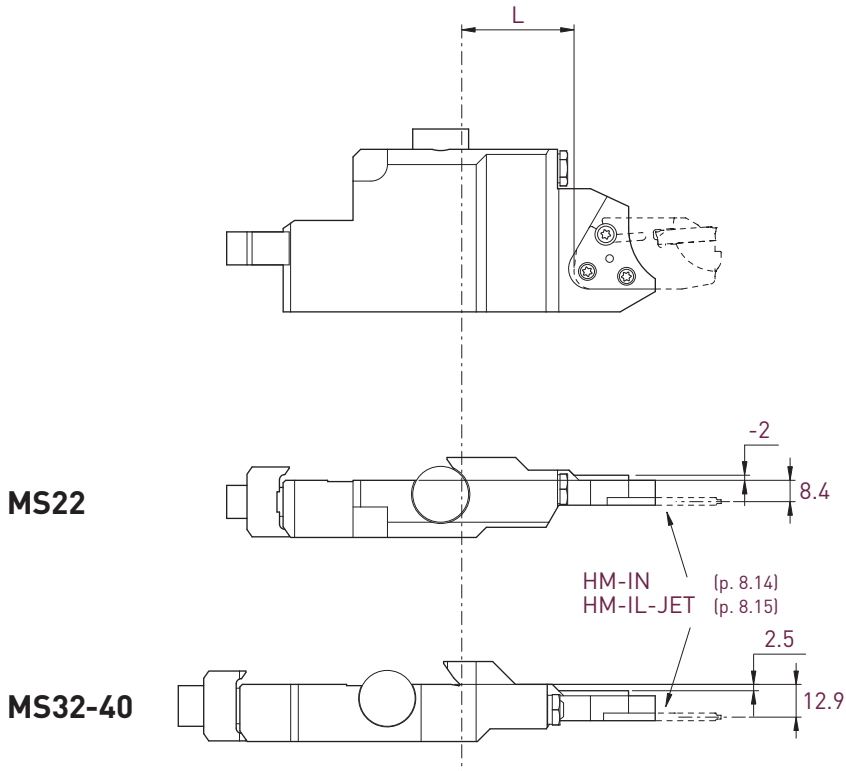

Pièces de rechange  
Ersatzteile  
Spare parts

Machine compatibility	L	Art. N°	Pièces de rechange Ersatzteile Spare parts		
			Art. N°	Art. N°	Art. N°
MS22	44.2	MS22-W5190231-HM-JET	V-M5X10-T20IP	V-M6X10-T20IP	C-T20IP
MS32-40	45.5	MS32-40-W5190233-HM-JET			

# EVO CUT-LINE

Lames pour système modulaire  
 Stechklinge für modulares System  
 Parting-off blades for modular system

HM Series

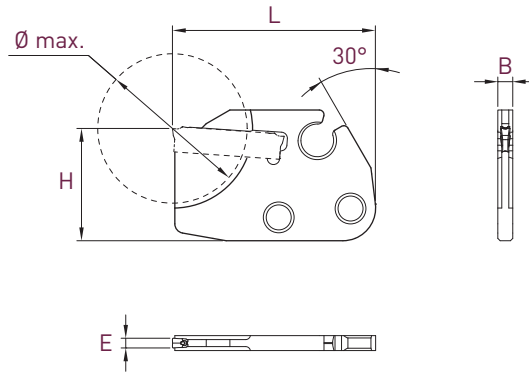

N

Plaquettes WSP Inserts	Ø max.	B	L	H	Art. N°
<b>E</b> 1.5 <b>Type</b> ET15	20	3.2	43.5	24	ET15-HM-IN-43-D20
	32	3.2	43.5	24	ET15-HM-IN-43-D32
<b>E</b> 2.0 <b>Type</b> ET20	20	3.2	43.5	24	ET20-HM-IN-43-D20
	26	3.2	43.5	24	ET20-HM-IN-43-D26
	26	3.2	54	24	ET20-HM-IN-54-D26
	32	3.2	43.5	24	ET20-HM-IN-43-D32
<b>E</b> 3.0 <b>Type</b> ET30	32	3.2	43.5	24	ET30-HM-IN-43-D32



Lames avec arrosage intégré

Stechklinge mit integrierter Kühlmittelzufuhr

Parting-off blades with integrated coolant supply

HM-JET Series

new

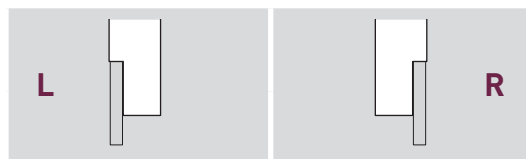
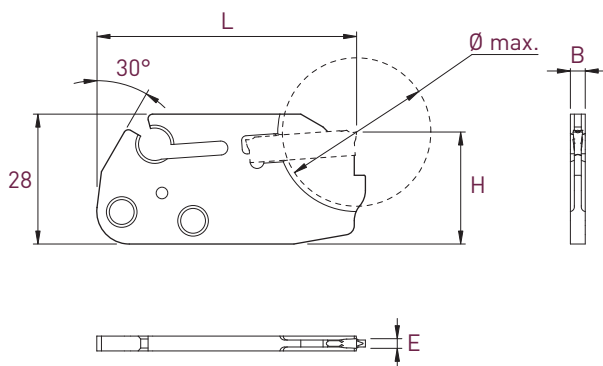

Plaquettes WSP Inserts	Ø max.	B	L	H	Art. N°	Art. N°
<b>E</b> 2.0 <b>Type</b> ET20	20	3.2	48.5	24	ET20-HM-IL-48.5-JET20	ET20-HM-IR-48.5-JET20
	24		48.5		ET20-HM-IL-48.5-JET24	ET20-HM-IR-48.5-JET24
	32		45.5		ET20-HM-IL-45.5-JET32	ET20-HM-IR-45.5-JET32
	32		56		ET20-HM-IL-56-JET32	ET20-HM-IR-56-JET32
	42		48.5		ET20-HM-IL-48.5-JET42	ET20-HM-IR-48.5-JET42
<b>E</b> 3.0 <b>Type</b> ET30	32	3.2	45.5	24	ET30-HM-IL-45.5-JET32	ET30-HM-IR-45.5-JET32
	44		48.5		ET30-HM-IL-48.5-JET42	ET30-HM-IR-48.5-JET42

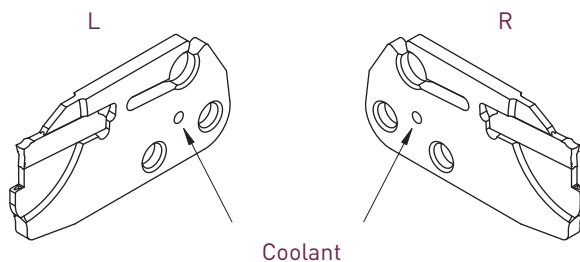

# EVOCUT-LINE

Lames de tronçonnage

Stechklinge

Parting-off blades

## HK Series

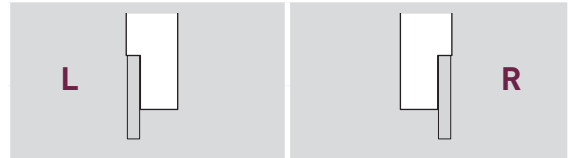
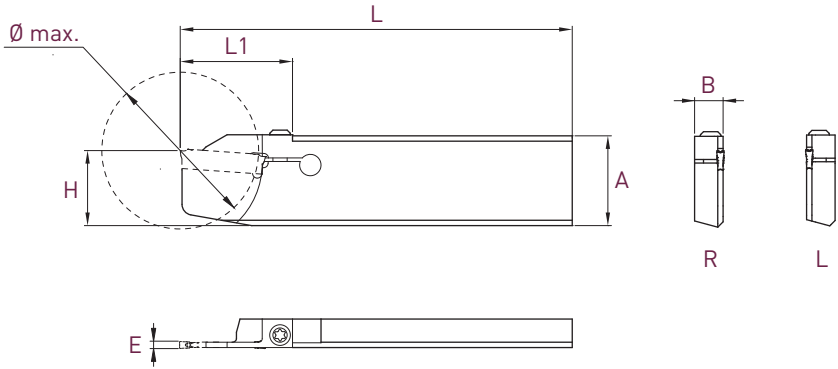

Plaquettes WSP Inserts	A x B	L	Ø max.	L1	H	Art. N°	Art. N°
<b>E</b> 1.5 Type ET15	26x8	110	20	19.5	21	<b>ET15-HK-2608L-110-D20</b>	<b>ET15-HK-2608R-110-D20</b>
	26x8	110	32	25.5	21	<b>ET15-HK-2608L-110-D32</b>	<b>ET15-HK-2608R-110-D32</b>
<b>E</b> 2.0 Type ET20	26x8	110	32	25.5	21	<b>ET20-HK-2608L-110-D32</b>	<b>ET20-HK-2608R-110-D32</b>
	26x8	110	44	31.5	21	<b>ET20-HK-2608L-110-D44</b>	<b>ET20-HK-2608R-110-D44</b>

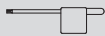
Pièces de rechange Ersatzteile Spare parts	 *	 *
	Art. N°	Art. N°
	<b>V-M4X14.5-T15-EVOCUT</b>	<b>C-T15</b>

\* livré avec chaque lame  
mit jedem Stechkling geliefert  
delivered with each blade

Lames de tronçonnage avec dégagement pour accès contre-broche

Stecklinge mit Aussparung für Gegenspindel Zugriff

Parting-off blades with recess for subspindle access

HK-RS Series

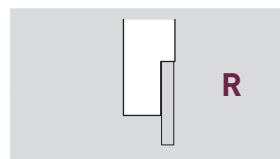
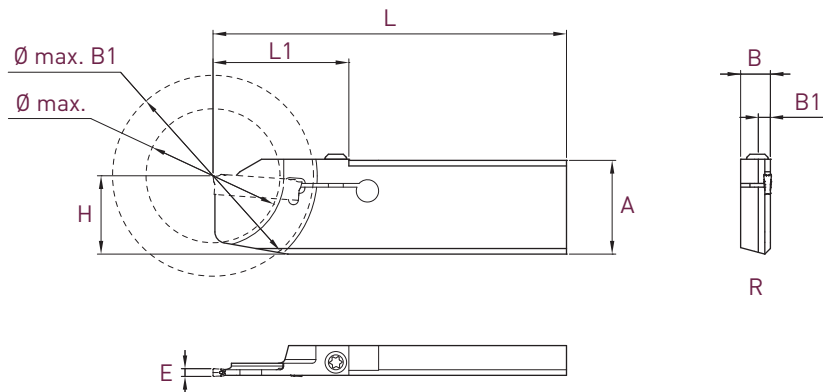

Plaquettes WSP Inserts	A x B	L	Ø max.	Ø max. B1	B1	L1	H	Art. N°
<b>E</b> 1.5 <b>Type</b> ET15	26x8	95	36	54	3.25	36.5	21	<b>ET15-HK-2608RS-95-D36</b>
<b>E</b> 2.0 <b>Type</b> ET20	26x8	95	36	54	3.25	36.5	21	<b>ET20-HK-2608RS-95-D36</b>

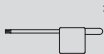
Pièces de rechange Ersatzteile Spare parts	 *	 *
	<b>Art. N°</b>	<b>Art. N°</b>
	<b>V-M4X14.5-T15-EVOCUT</b>	<b>C-T15</b>

\* livré avec chaque lame  
mit jedem Steckling geliefert  
delivered with each blade

# EVOCUT-LINE

Lames de tronçonnage inversées  
 Überkopf Stechklinge  
 Upside down parting-off blades

HUK Series

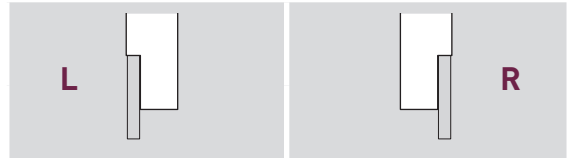
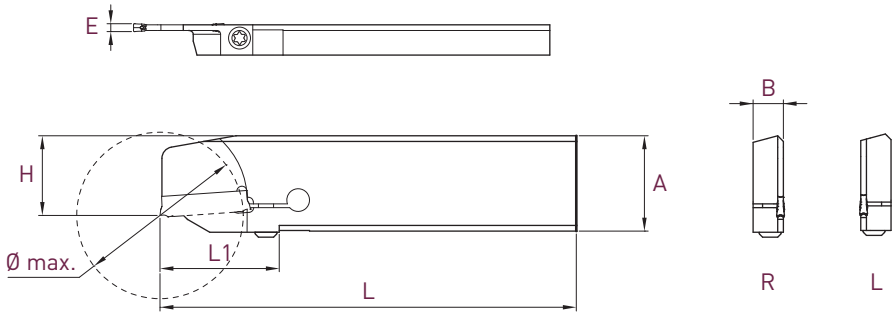

Plaquettes WSP Inserts	A x B	L	Ø max.	L1	H	Art. N°	Art. N°
<b>E</b> 1.5 Type ET15	26x8	110	20	19.5	21	<b>ET15-HUK-2608L-110-D20</b>	<b>ET15-HUK-2608R-110-D20</b>
	26x8	110	32	25.5	21	<b>ET15-HUK-2608L-110-D32</b>	<b>ET15-HUK-2608R-110-D32</b>
<b>E</b> 2.0 Type ET20	26x8	110	32	25.5	21	<b>ET20-HUK-2608L-110-D32</b>	<b>ET20-HUK-2608R-110-D32</b>
	26x8	110	44	31.5	21	<b>ET20-HUK-2608L-110-D44</b>	<b>ET20-HUK-2608R-110-D44</b>

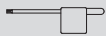
Pièces de rechange Ersatzteile Spare parts	 *	 *
	Art. N°	Art. N°
	<b>V-M4X14.5-T15-EVOCUT</b>	<b>C-T15</b>

\* livré avec chaque lame  
 mit jedem Steckling geliefert  
 delivered with each blade

# SWITCH-LINE



NEW



DISCOVER THE RANGE SWITCH-LINE IN CHAPTER 11!

# EVOCUT-LINE

Plaquettes de tronçonnage  
 Abstechwendeplatten  
 Cut off inserts

UN Series

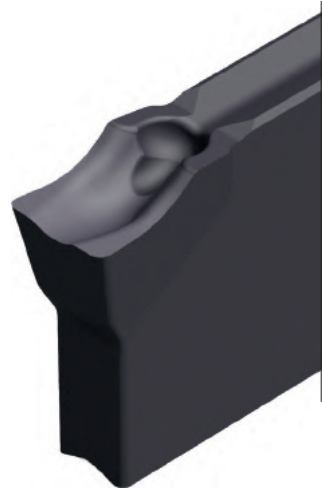
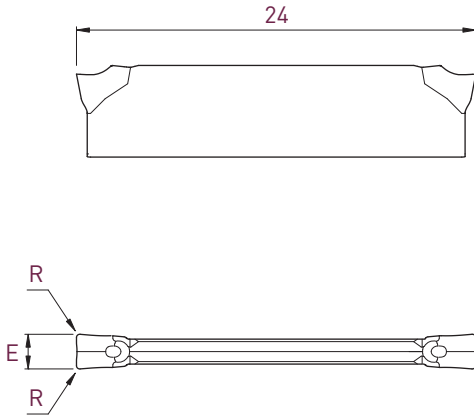

			UN				
Type	$E_{\pm 0.05}$	R	Art. N°	T:AIN	Tmax	Zmax	ZTi6
ET15	1.35	0	ET15-UN-000F	<input checked="" type="checkbox"/>	<input type="checkbox"/>	<input type="checkbox"/>	<input type="checkbox"/>
	1.5	0.2	ET15-UN-002	<input type="checkbox"/>	<input checked="" type="checkbox"/>	<input checked="" type="checkbox"/>	<input checked="" type="checkbox"/>
ET20	1.85	0	ET20-UN-000F	<input checked="" type="checkbox"/>	<input type="checkbox"/>	<input type="checkbox"/>	<input type="checkbox"/>
	2.0	0.2	ET20-UN-002	<input type="checkbox"/>	<input checked="" type="checkbox"/>	<input checked="" type="checkbox"/>	<input checked="" type="checkbox"/>
ET25	2.35	0	ET25-UN-000F	<input checked="" type="checkbox"/>	<input type="checkbox"/>	<input type="checkbox"/>	<input type="checkbox"/>
	2.5	0.3	ET25-UN-003	<input type="checkbox"/>	<input checked="" type="checkbox"/>	<input checked="" type="checkbox"/>	<input checked="" type="checkbox"/>
ET30	2.85	0	ET30-UN-000F	<input checked="" type="checkbox"/>	<input type="checkbox"/>	<input type="checkbox"/>	<input type="checkbox"/>
	3.0	0.3	ET30-UN-003	<input type="checkbox"/>	<input checked="" type="checkbox"/>	<input checked="" type="checkbox"/>	<input checked="" type="checkbox"/>

Plaquettes de tronçonnage

Abstechwendeplatten

Cut off inserts

UL-UR Series

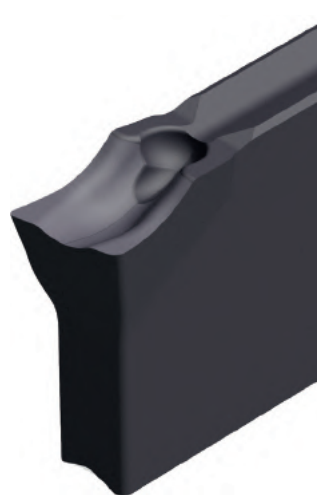
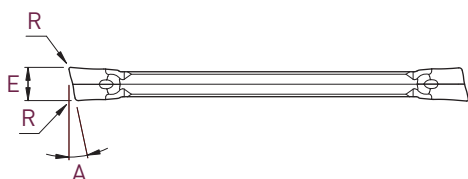
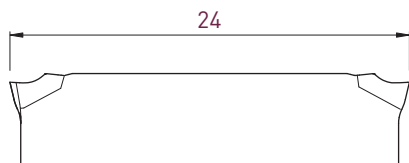

Type	E ±0.05	A	R	UL			UR				
				Art. N°	TiAlN	Tmax	Zmax	Art. N°	TiAlN	Tmax	Zmax
ET15	1.5	6°	0.2	-	<input type="checkbox"/>	<input type="checkbox"/>	<input type="checkbox"/>	ET15-UR-602	<input type="checkbox"/>	<input type="checkbox"/>	<input type="checkbox"/>
	1.35	8°	0	-	<input type="checkbox"/>	<input type="checkbox"/>	<input type="checkbox"/>	ET15-UR-800F	<input type="checkbox"/>	<input type="checkbox"/>	<input type="checkbox"/>
	1.5	12°	0.1	-	<input type="checkbox"/>	<input type="checkbox"/>	<input type="checkbox"/>	ET15-UR-1201	<input type="checkbox"/>	<input type="checkbox"/>	<input type="checkbox"/>
	1.35	15°	0	ET15-UL-1500F	<input checked="" type="checkbox"/>	<input type="checkbox"/>	<input type="checkbox"/>	ET15-UR-1500F	<input type="checkbox"/>	<input type="checkbox"/>	<input type="checkbox"/>
ET20	2.0	6°	0.2	-	<input type="checkbox"/>	<input type="checkbox"/>	<input type="checkbox"/>	ET20-UR-602	<input type="checkbox"/>	<input type="checkbox"/>	<input type="checkbox"/>
	1.85	8°	0	-	<input type="checkbox"/>	<input type="checkbox"/>	<input type="checkbox"/>	ET20-UR-800F	<input type="checkbox"/>	<input type="checkbox"/>	<input type="checkbox"/>
	2.0	12°	0.1	-	<input type="checkbox"/>	<input type="checkbox"/>	<input type="checkbox"/>	ET20-UR-1201	<input type="checkbox"/>	<input type="checkbox"/>	<input type="checkbox"/>
	1.85	15°	0	ET20-UL-1500F	<input checked="" type="checkbox"/>	<input type="checkbox"/>	<input type="checkbox"/>	ET20-UR-1500F	<input type="checkbox"/>	<input type="checkbox"/>	<input type="checkbox"/>
ET25	2.5	6°	0.2	-	<input type="checkbox"/>	<input type="checkbox"/>	<input type="checkbox"/>	ET25-UR-602	<input type="checkbox"/>	<input type="checkbox"/>	<input type="checkbox"/>
	2.35	8°	0	-	<input type="checkbox"/>	<input type="checkbox"/>	<input type="checkbox"/>	ET25-UR-800F	<input type="checkbox"/>	<input type="checkbox"/>	<input type="checkbox"/>
	2.5	12°	0.1	-	<input type="checkbox"/>	<input type="checkbox"/>	<input type="checkbox"/>	ET25-UR-1201	<input type="checkbox"/>	<input type="checkbox"/>	<input type="checkbox"/>
	2.35	15°	0	ET25-UL-1500F	<input checked="" type="checkbox"/>	<input type="checkbox"/>	<input type="checkbox"/>	ET25-UR-1500F	<input type="checkbox"/>	<input type="checkbox"/>	<input type="checkbox"/>
ET30	3.0	6°	0.3	-	<input type="checkbox"/>	<input type="checkbox"/>	<input type="checkbox"/>	ET30-UR-603	<input type="checkbox"/>	<input type="checkbox"/>	<input type="checkbox"/>
	2.85	8°	0	-	<input type="checkbox"/>	<input type="checkbox"/>	<input type="checkbox"/>	ET30-UR-800F	<input type="checkbox"/>	<input type="checkbox"/>	<input type="checkbox"/>
	3.0	12°	0.2	-	<input type="checkbox"/>	<input type="checkbox"/>	<input type="checkbox"/>	ET30-UR-1202	<input type="checkbox"/>	<input type="checkbox"/>	<input type="checkbox"/>
	2.85	15°	0	ET30-UL-1500F	<input checked="" type="checkbox"/>	<input type="checkbox"/>	<input type="checkbox"/>	ET30-UR-1500F	<input type="checkbox"/>	<input type="checkbox"/>	<input type="checkbox"/>

# EVOCUT-LINE

Plaquettes de tronçonnage  
 Abstechwendeplatten  
 Cut off inserts

JN Series

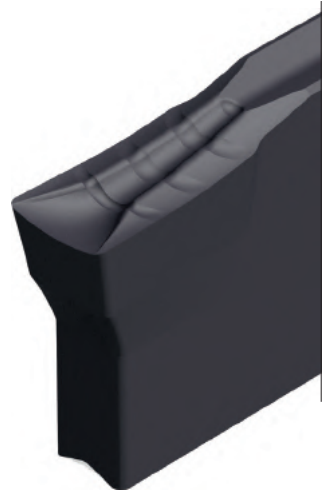
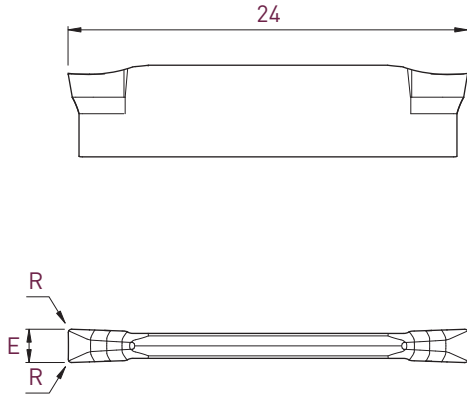

			JN				
Type	E ±0.05	R	Art. N°	T:AIN	Tmax	Zmax	ZTi6
ET15	1.5	0.2	ET15-JN-002	■	■	■	■
ET20	2.0	0.2	ET20-JN-002	■	■	■	■
ET25	2.5	0.3	ET25-JN-003	■	■	■	■
ET30	3.0	0.3	ET30-JN-003	■	■	■	■



Plaquettes de tronçonnage

Abstechwendeplatten

Cut off inserts

JR Series

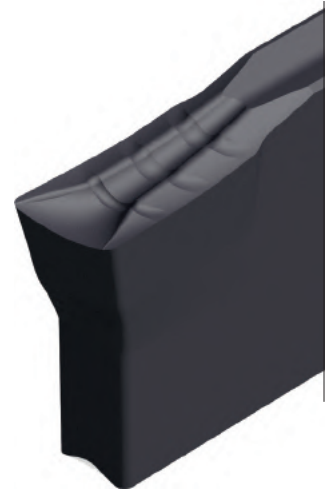
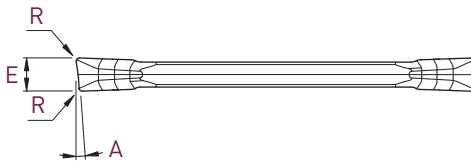
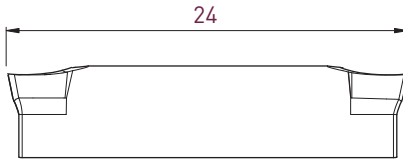

				JR			
Type	E $\pm 0.05$	A	R	Art. N°	TiAlN	Tmax	Zmax
ET15	1.5	6°	0.2	ET15-JR-602	■	■	■
ET20	2.0	6°	0.2	ET20-JR-602	■	■	■
ET25	2.5	6°	0.2	ET25-JR-602	■	■	■
ET30	3.0	6°	0.3	ET30-JR-603	■	■	■

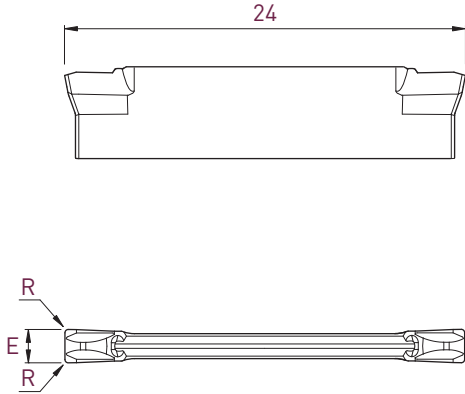

			TN 				
Type	E ±0.05	R	Art. N°	TiAlN <input type="checkbox"/>	Tmax <input type="checkbox"/>	Zmax <input type="checkbox"/>	ZTi6 <input type="checkbox"/>
ET20	2.0	0.2	ET20-TN-002	<input checked="" type="checkbox"/>	<input checked="" type="checkbox"/>	<input checked="" type="checkbox"/>	<input checked="" type="checkbox"/>
ET25	2.5	0.3	ET25-TN-003	<input checked="" type="checkbox"/>	<input checked="" type="checkbox"/>	<input checked="" type="checkbox"/>	<input checked="" type="checkbox"/>
ET30	3.0	0.3	ET30-TN-003	<input checked="" type="checkbox"/>	<input checked="" type="checkbox"/>	<input checked="" type="checkbox"/>	<input checked="" type="checkbox"/>

Plaquettes de tronçonnage

Abstechwendeplatten

Cut off inserts

Negative geometry

TR Series

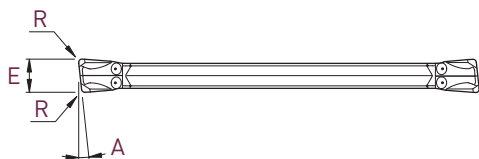
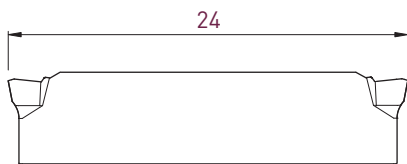

				TR																	
Type	E ±0.05	A	R	Art. N°	<table border="1"> <tr> <td><input type="checkbox"/></td><td><input type="checkbox"/></td><td><input type="checkbox"/></td><td><input type="checkbox"/></td> </tr> <tr> <td><input type="checkbox"/></td><td><input type="checkbox"/></td><td><input type="checkbox"/></td><td><input type="checkbox"/></td> </tr> <tr> <td><input type="checkbox"/></td><td><input type="checkbox"/></td><td><input type="checkbox"/></td><td><input type="checkbox"/></td> </tr> <tr> <td><input type="checkbox"/></td><td><input type="checkbox"/></td><td><input type="checkbox"/></td><td><input type="checkbox"/></td> </tr> </table>	<input type="checkbox"/>	<input type="checkbox"/>	<input type="checkbox"/>	<input type="checkbox"/>	<input type="checkbox"/>	<input type="checkbox"/>	<input type="checkbox"/>	<input type="checkbox"/>	<input type="checkbox"/>	<input type="checkbox"/>	<input type="checkbox"/>	<input type="checkbox"/>	<input type="checkbox"/>	<input type="checkbox"/>	<input type="checkbox"/>	<input type="checkbox"/>
<input type="checkbox"/>	<input type="checkbox"/>	<input type="checkbox"/>	<input type="checkbox"/>																		
<input type="checkbox"/>	<input type="checkbox"/>	<input type="checkbox"/>	<input type="checkbox"/>																		
<input type="checkbox"/>	<input type="checkbox"/>	<input type="checkbox"/>	<input type="checkbox"/>																		
<input type="checkbox"/>	<input type="checkbox"/>	<input type="checkbox"/>	<input type="checkbox"/>																		
ET20	2.0	6°	0.2	ET20-TR-602	■ ■ ■																
ET25	2.5	6°	0.2	ET25-TR-602	■ ■ ■																
ET30	3.0	6°	0.3	ET30-TR-603	■ ■ ■ ■																

# EVOCUT-LINE

Plaquettes de tronçonnage

Abstechwendeplatten

Cut off inserts

## AN Series

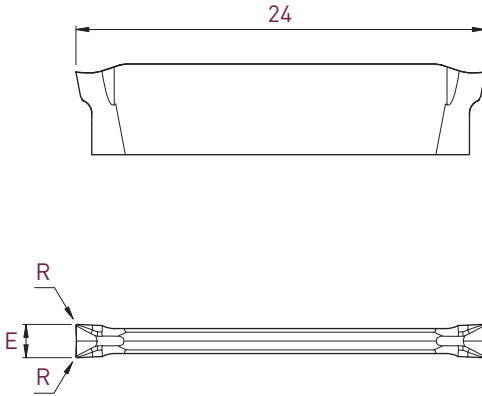

				AN		
Type	E $\pm 0.05$	R	Art. N°	T	A	N
ET20	2.0	0.2	ET20-AN-002F	<input checked="" type="checkbox"/>	<input checked="" type="checkbox"/>	<input checked="" type="checkbox"/>
ET30	3.0	0.3	ET30-AN-003F	<input checked="" type="checkbox"/>	<input checked="" type="checkbox"/>	<input checked="" type="checkbox"/>

Plaquettes de tronçonnage

Abstechwendeplatten

Cut off inserts

AR Series

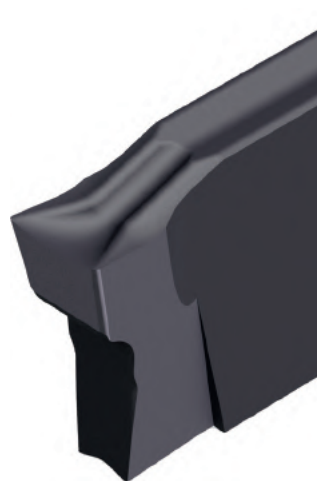
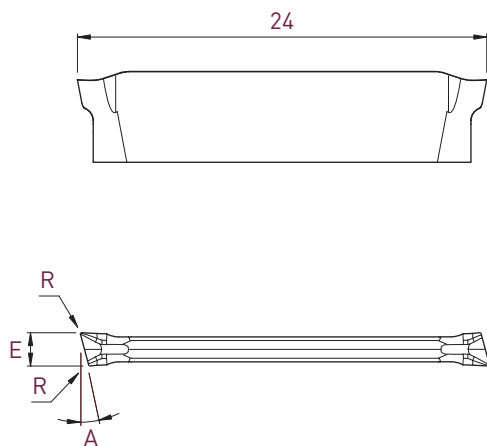











				AR			
Type	E ±0.05	A	R	Art. N°	TiAIN	AS	N
ET20	2.0	15°	0.1	ET20-AR-1501F	■	■	■
ET30	3.0	15°	0.2	ET30-AR-1502F	■	■	■

# EVOCUT-LINE

Paramètres de coupe indicatifs

Empfohlene Schnittwerte

Standard machining data

						P Acier Stahl Steel						M Inox Rostfreistahl Stainless steel					
		ET15		ET20		ET25		ET30		Acier de décolletage Automatenstahl Free-cutting steel		Acier faiblement allié Leicht legierter Stahl Low alloyed steel		Acier fortement allié Legierter Stahl High alloyed steel		Austenitique et martensitique Austenitic and martensitic	
		VC (m/min)	F (mm/U)	VC (m/min)	F (mm/U)	VC (m/min)	F (mm/U)	VC (m/min)	F (mm/U)	VC (m/min)	F (mm/U)	VC (m/min)	F (mm/U)				
Avance standard Standard Vorschub Standard feed rate	UN 	TiAlN	■	■	■	■	90-140	0.04-0.08	60-120	0.04-0.08	50-100	0.04-0.08	50-120	0.04-0.08			
		Tmax	■	■	■	■	100-170	0.04-0.08	70-150	0.04-0.08	60-120	0.04-0.08	60-150	0.04-0.08			
		Zmax	■	■	■	■	80-130*	0.04-0.10	50-110*	0.04-0.10	50-90*	0.04-0.10	50-120*	0.04-0.10			
		ZTi6	■	■	■	■	110-200	0.04-0.08	80-160	0.04-0.08	70-140	0.04-0.08	70-160	0.04-0.08			
	UR 	TiAlN	■	■	■	■	90-140	0.04-0.08	60-120	0.04-0.08	50-100	0.04-0.08	50-120	0.04-0.08			
		Tmax	■	■	■	■	100-170	0.04-0.08	70-150	0.04-0.08	60-120	0.04-0.08	60-150	0.04-0.08			
		Zmax	■	■	■	■	80-130*	0.04-0.10	50-110*	0.04-0.10	50-90*	0.04-0.10	50-120*	0.04-0.10			
		ZTi6	■	■	■	■	110-200	0.04-0.08	80-160	0.04-0.08	70-140	0.04-0.08	70-160	0.04-0.08			
	JN 	TiAlN	■	■	■	■	90-140	0.04-0.08	60-120	0.04-0.08	50-100	0.04-0.08	50-120	0.04-0.08			
		Tmax	■	■	■	■	100-170	0.04-0.08	70-150	0.04-0.08	60-120	0.04-0.08	60-150	0.04-0.08			
		Zmax	■	■	■	■	80-130*	0.04-0.10	50-110*	0.04-0.10	50-90*	0.04-0.10	50-120*	0.04-0.10			
		ZTi6	■	■	■	■	110-200	0.04-0.08	80-160	0.04-0.08	70-140	0.04-0.08	70-160	0.04-0.08			
	JR 	TiAlN	■	■	■	■	90-140	0.04-0.08	60-120	0.04-0.08	50-100	0.04-0.08	50-120	0.04-0.08			
		Tmax	■	■	■	■	100-170	0.04-0.08	70-150	0.04-0.08	60-120	0.04-0.08	60-150	0.04-0.08			
		Zmax	■	■	■	■	80-130*	0.04-0.10	50-110*	0.04-0.10	50-90*	0.04-0.10	50-120*	0.04-0.10			
		ZTi6	■	■	■	■	110-200	0.04-0.08	80-160	0.04-0.08	70-140	0.04-0.08	70-160	0.04-0.08			
	TN 	TiAlN	■	■	■	■	90-150	0.08-0.18	70-130	0.08-0.18	50-100	0.08-0.15	50-120	0.08-0.20			
		Tmax	■	■	■	■	100-170	0.08-0.18	70-150	0.08-0.18	60-120	0.08-0.15	60-150	0.08-0.20			
		Zmax	■	■	■	■	80-130*	0.08-0.18	50-110*	0.08-0.18	50-90*	0.08-0.15	50-120*	0.08-0.20			
		ZTi6	■	■	■	■	110-200	0.08-0.18	80-160	0.08-0.18	70-140	0.08-0.15	70-160	0.08-0.20			
	TR 	TiAlN	■	■	■	■	90-150	0.08-0.18	70-130	0.08-0.18	50-100	0.08-0.15	50-120	0.08-0.20			
		Tmax	■	■	■	■	100-170	0.08-0.18	70-150	0.08-0.18	60-120	0.08-0.15	60-150	0.08-0.20			
		Zmax	■	■	■	■	80-130*	0.08-0.18	50-110*	0.08-0.18	50-90*	0.08-0.15	50-120*	0.08-0.20			
		ZTi6	■	■	■	■	110-200	0.08-0.18	80-160	0.08-0.18	70-140	0.08-0.15	70-160	0.08-0.20			
Avance modérée Niedriger Vorschub Low feed rate	UN-000F 	TiAlN	■	■	■	■	80-120	0.02-0.05	50-100	0.02-0.05	40-80	0.02-0.05	40-100	0.02-0.05			
	UR/ULF 	TiAlN	■	■	■	■	80-120	0.02-0.05	50-100	0.02-0.05	40-80	0.02-0.05	40-100	0.02-0.05			
	ANF 	N	■	■	■	■											
		TiAlN	■	■	■	■							40-80	0.02-0.05			
	ARF 	N	■	■	■	■											
		TiAlN	■	■	■	■							40-80	0.02-0.05			
		AS	■	■	■	■											

\* premier choix en cas de coupe interrompue

\*\* arête de coupe vive

\* beste Basis für unterbrochene Schnitte

\*\* scharfe Schneidkante

\* first choice for interrupted cut

\*\* sharp cutting edge

N Alliage d'aluminium et non ferreux Aluminium- und Nichteisenlegierungen Aluminium and non-ferrous alloys								S Titane Titan Titanium			
Aluminium		Alu silicium max. 5% Aluminiumsilicium max. 5% Aluminium silicon max. 5%		Cuivre Kupfer Copper		Laiton & bronze Messing & Bronze Brass & bronze		Gr. 1 - 3		Gr. 4 - 5	
VC (m/min)	F (mm/U)	VC (m/min)	F (mm/U)	VC (m/min)	F (mm/U)	VC (m/min)	F (mm/U)	VC (m/min)	F (mm/U)	VC (m/min)	F (mm/U)
100-250	0.03-0.10	100-250	0.03-0.10	100-300	0.03-0.10	100-300	0.03-0.10			50-100	0.04-0.08
100-250	0.03-0.10	100-250	0.03-0.10	100-300	0.03-0.10	100-300	0.03-0.10			50-100	0.04-0.08
100-250	0.03-0.10	100-250	0.03-0.10	100-300	0.03-0.10	100-300	0.03-0.10			50-100	0.04-0.08
100-250	0.03-0.10	100-250	0.03-0.10	100-300	0.03-0.10	100-300	0.03-0.10			50-100	0.04-0.08
						150-300	0.05-0.20				
						150-300	0.05-0.20				
100-300	0.02-0.06	100-200	0.01-0.05	100-250	0.01-0.05	100-300	0.02-0.06			50-100	0.01-0.06
100-300	0.02-0.06	100-200	0.01-0.05	100-250	0.01-0.05	100-300	0.02-0.06			50-100	0.01-0.06
80-200	0.02-0.06			80-200	0.01-0.05	80-200	0.02-0.06	50-100	0.01-0.06	50-100	0.01-0.06
100-250	0.02-0.06	80-150	0.01-0.05	100-200	0.01-0.05	80-200	0.02-0.06			30-80	0.01-0.06
100-300	0.02-0.06	100-200	0.01-0.05	100-250	0.01-0.05	100-300	0.02-0.06	50-120	0.01-0.06	50-120	0.01-0.06
80-200	0.02-0.06			80-200	0.01-0.05	80-200	0.02-0.06	50-100	0.01-0.06	50-100	0.01-0.06
100-250	0.02-0.06	80-150	0.01-0.05	100-200	0.01-0.05	80-200	0.02-0.06			30-80	0.01-0.06
100-300	0.02-0.06	100-200	0.01-0.05	100-250	0.01-0.05	100-300	0.02-0.06	50-120	0.01-0.06	50-120	0.01-0.06



# CUT-LINE

APPLITEC

Porte-outils / Halter / Holders

**H** Système de serrage à bride, version courte  
Spannbrücke Klemmsystem, kurze Ausführung  
Independent top clamp system, short version

**HX** Système de serrage à bride, version longue  
Spannbrücke Klemmsystem, lange Ausführung  
Independent top clamp system, long version

**HZ** Porte-outils de grande capacité  
Klemmhalter für grössere Durchmesser  
High capacity tool holders

*Very rigid clamping system!*

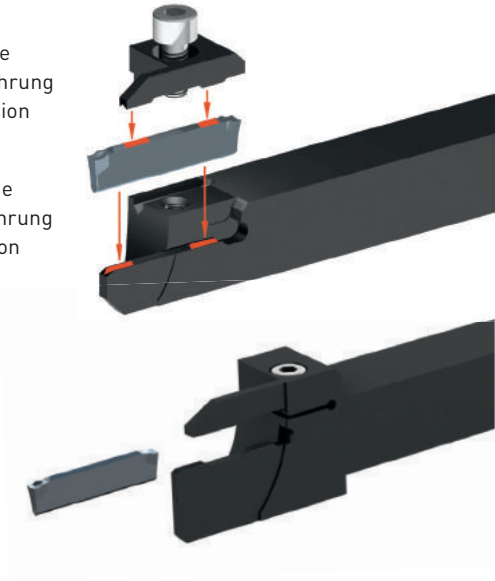

Plaquettes / WSP / Inserts

**CUT 16** =  1.6 mm Ø max 20 mm

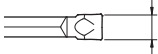
**CUT 22** =  2.2 mm Ø max 42 mm

**CUT 31** =  3.1 mm Ø max 65 mm



**U**



**P**



**T**



**G**



Nuances et géométries  
Sorten und Geometrien  
Grades and types of geometries > **9.02**

**CUT 16** Ø max 20 mm > **9.04**

Paramètres de coupe indicatifs  
Empfohlene Schnittwerte  
Standard machining data  
**CUT 22** Ø max 42 mm > **9.06**

**CUT 31** Ø max 65 mm > **9.08**

**H Series** > **9.10**

Porte-outils  
Halter  
Holders  
**HX Series** > **9.11**

**HZ Series** > **9.12**

Porte-outils avec arrosage intégré  
Halter mit integrierter Kühlmittelzufuhr  
Holders with integrated coolant supply  
**HZ-JET Series** > **9.13**

**U Series** > **9.14**

Plaquettes de tronçonnage  
Abstechwendeplatten  
Cut off inserts  
**P Series** > **9.16**

**T Series** > **9.20**

Plaquettes de fonçage, tournage et tronçonnage  
WSP zum einstecken, drehen und abstechen  
Inserts for grooving, turning and cut off  
**G Series** > **9.21**

<h3>TiAlN</h3> <p>revêtement PVD PVD Beschichtung PVD coating</p>	<h3>Tmax</h3> <p>revêtement PVD PVD Beschichtung PVD coating</p>	<h3>Zmax</h3> <p>revêtement PVD PVD Beschichtung PVD coating</p>
<ul style="list-style-type: none"> <li>pour l'usinage des aciers, aciers inoxydables et alliages de titane</li> <li>1<sup>er</sup> choix pour les avances faibles à modérées</li> </ul>	<ul style="list-style-type: none"> <li>nuance pour usinage moyen à lourd des aciers, aciers alliés et inoxydables</li> <li>bonne résistance aux températures d'usinage élevées</li> <li>1<sup>er</sup> choix pour le tronçonnage des aciers au carbone et des aciers fortement alliés</li> </ul>	<ul style="list-style-type: none"> <li>pour l'usinage des aciers, aciers inoxydables et alliages de titane en conditions défavorables</li> <li>bonne résistance aux chocs à des vitesses de coupe moyenne à faible</li> <li>1<sup>er</sup> choix pour le tronçonnage en coupe interrompue</li> </ul>
<ul style="list-style-type: none"> <li>für die Bearbeitung von Stahl, rostfreiem Stahl und Titanlegierungen</li> <li>beste Wahl für niedrige bis mittlere Vorschübe</li> </ul>	<ul style="list-style-type: none"> <li>Sorte für mittlere bis hohe Belastung in Stahl und legierter Stahlbearbeitung</li> <li>gute Bearbeitungswarmfestigkeit</li> <li>für die Bearbeitung von legiertem Kohlenstahl und hoch legiertem Stahl bestens geeignet</li> </ul>	<ul style="list-style-type: none"> <li>für die Bearbeitung von Stahl, rostfreiem Stahl und Titanlegierungen in schwierige Bearbeitungsfälle</li> <li>gute Bruchfestigkeit mit durchschnittliche bis niedrige Schnittgeschwindigkeit</li> <li>für die Bearbeitung in unterbrochenen Schnitte bestens geeignet</li> </ul>
<ul style="list-style-type: none"> <li>for machining of steel, stainless steel and titanium alloys</li> <li>first choice for low to average cutting speed</li> </ul>	<ul style="list-style-type: none"> <li>grade for medium to heavy machining of steel, stainless steel and alloyed steel</li> <li>high machining heat resistance</li> <li>first choice for the machining of carbon steel and high alloyed steel</li> </ul>	<ul style="list-style-type: none"> <li>for machining of steel, stainless steel and titanium alloys in unfavourable machining conditions</li> <li>good impact resistance with average to low cutting speed</li> <li>first choice for machining in interrupted cut</li> </ul>
<h3>HTA</h3> <p>revêtement PVD PVD Beschichtung PVD coating</p>	<h3>AS</h3> <p>revêtement PVD PVD Beschichtung PVD coating</p>	<h3>N</h3> <p>non revêtu unbeschichtet uncoated</p>
<ul style="list-style-type: none"> <li>très bonne résistance à l'usure</li> <li>pour le tronçonnage des aciers, aciers inoxydables et alliages de titane</li> <li>déconseillé en coupe interrompue</li> </ul>	<ul style="list-style-type: none"> <li>nuance pour métaux non ferreux</li> <li>très faible coefficient de frottement</li> <li>1<sup>er</sup> choix pour l'usinage des aluminiums jusqu'à 5% Si, des cuivres et titanes faiblement alliés</li> </ul>	<ul style="list-style-type: none"> <li>nuance pour les laitons, pour la géométrie PNW et PRW</li> </ul>
<ul style="list-style-type: none"> <li>sehr gute Verschleissfestigkeit</li> <li>für die Bearbeitung von Stahl, rostfreiem Stahl und Titanlegierung bestens geeignet</li> <li>für unterbrochene Schnitte ungeeignet</li> </ul>	<ul style="list-style-type: none"> <li>Sorte für Nichteisenmetalle</li> <li>sehr geringer Reibwert</li> <li>für die Bearbeitung von Aluminium bis 5% Si, Kupfer und niedriglegiertem Titan bestens geeignet</li> </ul>	<ul style="list-style-type: none"> <li>Sorte für Messing, für PNW und PRW Geometrie</li> </ul>
<ul style="list-style-type: none"> <li>very good wear resistance</li> <li>first choice for steel, stainless steel and titanium alloys machining</li> <li>not suitable for interrupted cut</li> </ul>	<ul style="list-style-type: none"> <li>grade for non-ferrous materials</li> <li>very low friction ratio</li> <li>first choice for Aluminium up to 5% Si, copper and low alloyed titanium</li> </ul>	<ul style="list-style-type: none"> <li>grade for brass, for PNW and PRW geometry</li> </ul>

Géométries de coupe

Spanformgeometrie

Cutting geometries

UN

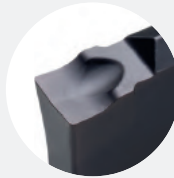
UR  
UL

- géométrie positive universelle, bonne maîtrise du copeau
- allgemeine Geometrie, sehr gute Spankontrolle
- all-round insert with efficient chip control

PN

PR

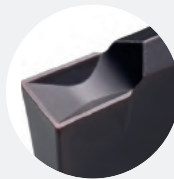

- géométrie légèrement positive pour les aciers, aciers au carbone, aciers alliés
- leicht positive Geometrie für Stahl, Kohlenstoffstahl, legiertem Stahl
- slightly positive geometry for steel, carbon steel, alloyed steel

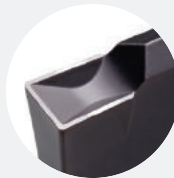
PNW  
PRW

- géométrie neutre pour les laitons
- neutrale Geometrie für Messing
- neutral geometry for brasses

TN



- géométrie négative pour de fortes avances dans des conditions de rigidité favorable
- negative Geometrie für hohe Vorschübe in guten Stabilitätsfällen
- negative geometry for high feed rate in case of good stability

GN



- géométrie universelle pour fonçage-tournage, peut également être utilisée en tronçonnage
- allgemeine Geometrie zum einstecken-langdrehen, kann auch zum abstechen verwendet werden
- all-round insert for grooving and turning, can also be used for parting off







# CUT-LINE

Paramètres de coupe indicatifs

Empfohlene Schnittwerte

Standard machining data

## CUT 16

		P Acier Stahl Steel						M Inox Rostfreistahl Stainless steel		
		Acier de décolletage Automatenstahl Free-cutting steel		Acier faiblement allié Leicht legierter Stahl Low alloyed steel		Acier fortement allié Legierter Stahl High alloyed steel		Austénitique et martensitique Austenitisch und martensitisch Austenitic and martensitic		
		VC (m/min)	F (mm/U)	VC (m/min)	F (mm/U)	VC (m/min)	F (mm/U)	VC (m/min)	F (mm/U)	
Avance standard Standard Vorschub Standard feed rate	CUT16-UN-001 	TiAlN	90-140	0.03-0.07	60-120	0.03-0.07	50-100	0.04-0.08	50-120	0.03-0.07
		Tmax	100-170	0.03-0.07	70-150	0.03-0.07	60-120	0.04-0.08	60-150	0.03-0.07
		Zmax	80-130*	0.04-0.10	50-110*	0.04-0.10	50-90*	0.04-0.08	50-120*	0.04-0.10
		HTA	70-120	0.03-0.05	60-100	0.03-0.05	50-90	0.03-0.05	50-100	0.03-0.06
		AS								
	CUT16-PR-801 	TiAlN	90-140	0.03-0.07	60-120	0.03-0.07	50-100	0.03-0.07	50-120	0.03-0.07
	Tmax	100-170	0.03-0.07	70-150	0.03-0.07	60-120	0.03-0.07	60-150	0.03-0.07	
CUT16-PRW-801 	N									
Avance modérée Niedriger Vorschub Low feed rate	CUT16-UN-000F 	TiAlN	80-130	0.02-0.05	50-110	0.02-0.05	50-90	0.02-0.05	50-80	0.02-0.05
		HTA	60-100	0.01-0.04	50-90	0.01-0.04	50-80	0.02-0.05	50-80	0.02-0.05
		AS								
	CUT16-UL/R-800F 	TiAlN	80-130	0.02-0.05	50-110	0.02-0.05	50-90	0.02-0.05	50-80	0.02-0.05
		HTA	60-100	0.01-0.04	50-90	0.01-0.04	50-80	0.02-0.05	50-80	0.02-0.05
		AS								
	CUT16-UL/R-1500F 	TiAlN	80-130	0.02-0.05	50-110	0.02-0.05	50-90	0.02-0.05	50-80	0.02-0.05
		HTA	60-100	0.01-0.04	50-90	0.01-0.04	50-80	0.02-0.05	50-80	0.02-0.05
		AS								

\*\* arête de coupe vive

\*\* scharfe Schneidkante

\*\* sharp cutting edge

N Alliage d'aluminium et non ferreux Aluminium- und Nichteisenlegierungen Aluminium and non-ferrous alloys								S Titane Titan Titanium			
Aluminium		Alu silicium max. 5% Aluminiumsilicium max. 5% Aluminium silicon max. 5%		Cuivre Kupfer Copper		Laiton & bronze Messing & Bronze Brass & bronze		Gr. 1 - 3		Gr. 4 - 5	
VC (m/min)	F (mm/U)	VC (m/min)	F (mm/U)	VC (m/min)	F (mm/U)	VC (m/min)	F (mm/U)	VC (m/min)	F (mm/U)	VC (m/min)	F (mm/U)
100-250	0.03-0.10	100-250	0.03-0.10	100-300	0.03-0.10	100-300	0.03-0.10			30-60	0.04-0.08
100-300	0.04-0.10	100-250	0.04-0.10	100-300	0.03-0.08	150-300	0.03-0.08			30-60	0.04-0.08
150-300	0.04-0.15	100-300	0.04-0.10	100-300	0.04-0.10	150-300	0.02-0.08	30-60	0.04-0.08	30-60	0.04-0.08
						150-300	0.03-0.10				
						100-500	0.02-0.10				
100-300	0.02-0.05	100-250	0.01-0.04	100-250	0.01-0.04	100-300	0.02-0.05			30-60	0.01-0.04
100-300	0.02-0.05	100-250	0.02-0.05	100-250	0.02-0.05	100-300	0.02-0.05			30-60	0.02-0.06
100-300	0.02-0.05	100-250	0.02-0.05	100-250	0.02-0.05	100-300	0.02-0.05	30-60	0.02-0.06	30-60	0.02-0.06
100-300	0.02-0.05	100-250	0.01-0.04	100-250	0.01-0.04	100-300	0.02-0.05			30-60	0.01-0.04
100-300	0.02-0.05	100-250	0.02-0.05	100-250	0.02-0.05	100-300	0.02-0.05			30-60	0.02-0.06
100-300	0.02-0.05	100-250	0.02-0.05	100-250	0.02-0.05	100-300	0.02-0.05	30-60	0.02-0.06	30-60	0.02-0.06
100-300	0.02-0.05	100-250	0.01-0.04	100-250	0.01-0.04	100-300	0.02-0.05			30-60	0.01-0.04
100-300	0.02-0.05	100-250	0.02-0.05	100-250	0.02-0.05	100-300	0.02-0.05			30-60	0.02-0.06
100-300	0.02-0.05	100-250	0.02-0.05	100-250	0.02-0.05	100-300	0.02-0.05	30-60	0.02-0.06	30-60	0.02-0.06









# CUT-LINE

Paramètres de coupe indicatifs

Empfohlene Schnittwerte

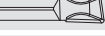
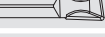
Standard machining data

## CUT 22

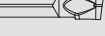
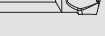
			P Acier Stahl Steel						M Inox Rostfreistahl Stainless steel	
			Acier de décolletage Automatenstahl Free-cutting steel		Acier faiblement allié Leicht legierter Stahl Low alloyed steel		Acier fortement allié Legierter Stahl High alloyed steel		Austénitique et martensitique Austenitisch und martensitisch Austenitic and martensitic	
			VC (m/min)	F (mm/U)	VC (m/min)	F (mm/U)	VC (m/min)	F (mm/U)	VC (m/min)	F (mm/U)
Avance standard Standard Vorschub Standard feed rate	CUT22-UN-002 CUT22-UR-802 	TiAlN	90-140	0.04-0.08	60-120	0.04-0.08	50-100	0.04-0.08	50-120	0.04-0.08
		Tmax	100-170	0.04-0.08	70-150	0.04-0.08	60-120	0.04-0.08	60-150	0.04-0.08
		Zmax	80-130*	0.04-0.10	50-110*	0.04-0.10	50-90*	0.04-0.08	50-120*	0.04-0.10
		HTA	70-120	0.04-0.06	60-100	0.04-0.06	50-90	0.04-0.06	50-100	0.04-0.06
		AS								
	CUT22-PN-002 	TiAlN	90-140	0.04-0.10	60-120	0.04-0.08	50-100	0.04-0.08		
	Tmax	100-170	0.04-0.10	70-150	0.04-0.10	60-120	0.04-0.10			
	CUT22-PNW-002 	N								
	CUT22-PR-002 	TiAlN	90-140	0.04-0.08	60-120	0.04-0.08	50-100	0.04-0.08	50-120	0.04-0.08
	Tmax	100-170	0.04-0.08	70-150	0.04-0.08	60-120	0.04-0.08	60-150	0.04-0.08	
CUT22-PRW-002 	N									
CUT22-TN-002 	TiAlN	90-140	0.08-0.18	60-120	0.08-0.18	50-100	0.08-0.15	50-120	0.08-0.20	
Tmax	100-170	0.08-0.18	70-150	0.08-0.18	60-120	0.08-0.15	60-150	0.08-0.20		
Zmax	80-130*	0.08-0.18	50-110*	0.08-0.18	50-90*	0.08-0.15				
CUT22-GN-002 *** 	TiAlN	90-140	0.03-0.12	60-120	0.03-0.12	50-100	0.03-0.10	50-120	0.03-0.08	
Tmax	100-170	0.03-0.12	70-150	0.03-0.12	60-120	0.03-0.10	70-120	0.03-0.08		
AS										
Avance modérée Niedriger Vorschub Low feed rate	CUT22-UN-000F 	TiAlN	80-130	0.02-0.05	50-110	0.02-0.05	50-90	0.02-0.05	50-80	0.02-0.05
		HTA	60-100	0.01-0.04	50-90	0.01-0.04	50-80	0.02-0.05	50-80	0.02-0.05
		AS								
	CUT22-UL/R-800F 	TiAlN	80-130	0.02-0.05	50-110	0.02-0.05	50-90	0.02-0.05	50-80	0.02-0.05
		HTA	60-100	0.01-0.04	50-90	0.01-0.04	50-80	0.02-0.05	50-80	0.02-0.05
		AS								
	CUT22-UL/R-802F 	TiAlN	80-130	0.02-0.05	50-110	0.02-0.05	50-90	0.02-0.05	50-80	0.02-0.05
		HTA	60-100	0.01-0.04	50-90	0.01-0.04	50-80	0.02-0.05	50-80	0.02-0.05
		AS								
	CUT22-UL/R-1500F 	TiAlN	80-130	0.02-0.05	50-110	0.02-0.05	50-90	0.02-0.05	50-80	0.02-0.05
		HTA	60-100	0.01-0.04	50-90	0.01-0.04	50-80	0.02-0.05	50-80	0.02-0.05
		AS								

\* premier choix en cas de coupe interrompue

\*\* arête de coupe vive

\*\*\* géométrie fonçage-tournage (évent. tronçonnage)

\* beste Basis für unterbrochene Schnitte

\*\* scharfe Schneidkante

\*\*\* Geometrie zum einstechen und drehen (event. abstechen)

\* first choice for interrupted cut

\*\* sharp cutting edge

\*\*\* geometry for grooving and turning (event. parting off)

N Allages d'aluminium et non ferreux Aluminium- und Nichteisenlegierungen Aluminium and non-ferrous alloys								S Titane Titan Titanium			
Aluminium		Alu silicium max. 5% Aluminiumsilicium max. 5% Aluminium silicium max. 5%		Cuivre Kupfer Copper		Laiton & bronze Messing & Bronze Brass & bronze		Gr. 1 - 3		Gr. 4 - 5	
VC (m/min)	F (mm/U)	VC (m/min)	F (mm/U)	VC (m/min)	F (mm/U)	VC (m/min)	F (mm/U)	VC (m/min)	F (mm/U)	VC (m/min)	F (mm/U)
100-250	0.03-0.10	100-250	0.03-0.10	100-300	0.03-0.10	100-300	0.03-0.10			30-60	0.04-0.08
100-300	0.04-0.10	100-250	0.04-0.10	100-300	0.03-0.08	150-300	0.03-0.08			30-60	0.04-0.08
150-300	0.04-0.15	100-300	0.04-0.10	100-300	0.04-0.10	150-300	0.02-0.08	30-60	0.04-0.08	30-60	0.04-0.08
						150-300	0.03-0.10				
						100-500	0.02-0.10				
						150-300	0.03-0.10				
						100-500	0.02-0.10				
						150-300	0.05-0.20				
100-300	0.03-0.12	100-200	0.03-0.10	100-200	0.03-0.10	100-300	0.03-0.12			30-60	0.04-0.08
						100-300	0.03-0.12				
100-300	0.03-0.12	100-200	0.03-0.10	100-200	0.03-0.10	100-300	0.03-0.12	30-60	0.04-0.08	30-60	0.04-0.08
100-300	0.02-0.05	100-250	0.01-0.04	100-250	0.01-0.04	100-300	0.02-0.05			30-60	0.01-0.04
100-300	0.02-0.05	100-250	0.02-0.05	100-250	0.02-0.05	100-300	0.02-0.05			30-60	0.02-0.06
100-300	0.02-0.05	100-250	0.02-0.05	100-250	0.02-0.05	100-300	0.02-0.05	30-60	0.02-0.06	30-60	0.02-0.06
100-300	0.02-0.05	100-250	0.01-0.04	100-250	0.01-0.04	100-300	0.02-0.05			30-60	0.01-0.04
100-300	0.02-0.05	100-250	0.02-0.05	100-250	0.02-0.05	100-300	0.02-0.05			30-60	0.02-0.06
100-300	0.02-0.05	100-250	0.02-0.05	100-250	0.02-0.05	100-300	0.02-0.05	30-60	0.02-0.06	30-60	0.02-0.06
100-300	0.02-0.05	100-250	0.01-0.04	100-250	0.01-0.04	100-300	0.02-0.05			30-60	0.01-0.04
100-300	0.02-0.05	100-250	0.02-0.05	100-250	0.02-0.05	100-300	0.02-0.05			30-60	0.02-0.06
100-300	0.02-0.05	100-250	0.02-0.05	100-250	0.02-0.05	100-300	0.02-0.05	30-60	0.02-0.06	30-60	0.02-0.06
100-300	0.02-0.05	100-250	0.01-0.04	100-250	0.01-0.04	100-300	0.02-0.05			30-60	0.01-0.04
100-300	0.02-0.05	100-250	0.02-0.05	100-250	0.02-0.05	100-300	0.02-0.05			30-60	0.02-0.06
100-300	0.02-0.05	100-250	0.02-0.05	100-250	0.02-0.05	100-300	0.02-0.05	30-60	0.02-0.06	30-60	0.02-0.06









# CUT-LINE

Paramètres de coupe indicatifs

Empfohlene Schnittwerte

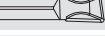
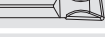
Standard machining data

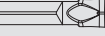
## CUT 31

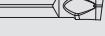
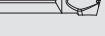
		P Acier Stahl Steel						M Inox Rostfreistahl Stainless steel		
		Acier de décolletage Automatenstahl Free-cutting steel		Acier faiblement allié Leicht legierter Stahl Low alloyed steel		Acier fortement allié Legierter Stahl High alloyed steel		Austénitique et martensitique Austenitisch und martensitisch Austenitic and martensitic		
		VC (m/min)	F (mm/U)	VC (m/min)	F (mm/U)	VC (m/min)	F (mm/U)	VC (m/min)	F (mm/U)	
Avance standard Standard Vorschub Standard feed rate	CUT31-UN-002 	TiAlN	90-140	0.04-0.08	60-120	0.04-0.08	50-100	0.04-0.08	50-120	0.04-0.10
		Tmax	100-170	0.04-0.08	70-150	0.04-0.08	60-120	0.04-0.08	60-150	0.04-0.10
		Zmax	80-130*	0.04-0.10	50-110*	0.04-0.10	50-90*	0.04-0.08	50-120*	0.04-0.10
		HTA	70-120	0.04-0.06	60-100	0.04-0.06	50-90	0.04-0.06	50-100	0.04-0.06
		AS								
	CUT31-PN-002 	TiAlN	90-140	0.04-0.10	60-120	0.04-0.08	50-100	0.04-0.08		
		Tmax	100-170	0.04-0.10	70-150	0.04-0.10	60-120	0.04-0.10		
	CUT31-PNW-002 	N								
	CUT31-PR-802 	TiAlN	90-140	0.04-0.08	60-120	0.04-0.08	50-100	0.04-0.08	50-120	0.04-0.08
		Tmax	100-170	0.04-0.08	70-150	0.04-0.08	60-120	0.04-0.08	60-150	0.04-0.08
CUT31-PRW-802 	N									
CUT31-TN-002 	TiAlN	90-140	0.08-0.20	60-120	0.08-0.20	50-100	0.08-0.15	50-120	0.08-0.20	
	Tmax	100-170	0.08-0.20	70-150	0.08-0.20	60-120	0.08-0.15	60-150	0.08-0.20	
	Zmax	80-130*	0.08-0.20	50-110*	0.08-0.20	50-90*	0.08-0.15			
CUT31-GN-002 *** 	TiAlN	90-140	0.04-0.15	60-120	0.04-0.15	50-100	0.04-0.10	50-120	0.04-0.10	
	Tmax	100-170	0.04-0.15	70-150	0.04-0.15	60-120	0.04-0.10	70-120	0.04-0.10	
	AS									
Avance modérée Niedriger Vorschub Low feed rate	CUT31-UN-000F 	TiAlN	80-130	0.02-0.05	50-110	0.02-0.05	50-90	0.02-0.05	50-80	0.02-0.05
		HTA	60-100	0.01-0.04	50-90	0.01-0.04	50-80	0.02-0.05	50-80	0.02-0.05
		AS								
	CUT31-UL/R-800F 	TiAlN	80-130	0.02-0.05	50-110	0.02-0.05	50-90	0.02-0.05	50-80	0.02-0.05
		HTA	60-100	0.01-0.04	50-90	0.01-0.04	50-80	0.02-0.05	50-80	0.02-0.05
		AS								
	CUT31-UL/R-802F 	TiAlN	80-130	0.02-0.05	50-110	0.02-0.05	50-90	0.02-0.05	50-80	0.02-0.05
		HTA	60-100	0.01-0.04	50-90	0.01-0.04	50-80	0.02-0.05	50-80	0.02-0.05
		AS								
	CUT31-UL/R-1500F 	TiAlN	80-130	0.02-0.05	50-110	0.02-0.05	50-90	0.02-0.05	50-80	0.02-0.05
		HTA	60-100	0.01-0.04	50-90	0.01-0.04	50-80	0.02-0.05	50-80	0.02-0.05
		AS								

\* premier choix en cas de coupe interrompue

\*\* arête de coupe vive

\*\*\* géométrie fonçage-tournage (évent. tronçonnage)

\* beste Basis für unterbrochene Schnitte

\*\* scharfe Schneidkante

\*\*\* Geometrie zum einstechen und drehen (event. abstechen)

\* first choice for interrupted cut

\*\* sharp cutting edge

\*\*\* geometry for grooving and turning (event. parting off)



N Allages d'aluminium et non ferreux Aluminium- und Nichteisenlegierungen Aluminium and non-ferrous alloys								S Titane Titan Titanium			
Aluminium		Alu silicium max. 5% Aluminiumsilicium max. 5% Aluminium silicium max. 5%		Cuivre Kupfer Copper		Laiton & bronze Messing & Bronze Brass & Bronze		Gr. 1 - 3		Gr. 4 - 5	
VC (m/min)	F (mm/U)	VC (m/min)	F (mm/U)	VC (m/min)	F (mm/U)	VC (m/min)	F (mm/U)	VC (m/min)	F (mm/U)	VC (m/min)	F (mm/U)
100-250	0.03-0.10	100-250	0.03-0.10	100-300	0.03-0.10	100-300	0.03-0.10			30-60	0.04-0.08
100-300	0.04-0.10	100-250	0.04-0.10	100-300	0.03-0.08	150-300	0.03-0.08			30-60	0.04-0.08
150-300	0.04-0.15	100-300	0.04-0.10	100-300	0.04-0.10	150-300	0.02-0.08	30-60	0.04-0.08	30-60	0.04-0.08
						150-300	0.03-0.10				
						100-500	0.02-0.15				
						150-300	0.03-0.10				
						100-500	0.02-0.15				
						150-300	0.05-0.20				
100-300	0.04-0.15	100-200	0.04-0.10	100-200	0.04-0.10	100-300	0.04-0.15			30-60	0.04-0.08
						100-300	0.04-0.15				
100-300	0.04-0.15	100-200	0.04-0.10	100-200	0.04-0.10	100-300	0.04-0.15	30-60	0.04-0.08	30-60	0.04-0.08
100-300	0.02-0.05	100-250	0.01-0.04	100-250	0.01-0.04	100-300	0.02-0.05			30-60	0.01-0.04
100-300	0.02-0.05	100-250	0.02-0.05	100-250	0.02-0.05	100-300	0.02-0.05			30-60	0.02-0.06
100-300	0.02-0.05	100-250	0.02-0.05	100-250	0.02-0.05	100-300	0.02-0.05	30-60	0.02-0.06	30-60	0.02-0.06
100-300	0.02-0.05	100-250	0.01-0.04	100-250	0.01-0.04	100-300	0.02-0.05			30-60	0.01-0.04
100-300	0.02-0.05	100-250	0.02-0.05	100-250	0.02-0.05	100-300	0.02-0.05			30-60	0.02-0.06
100-300	0.02-0.05	100-250	0.02-0.05	100-250	0.02-0.05	100-300	0.02-0.05	30-60	0.02-0.06	30-60	0.02-0.06
100-300	0.02-0.05	100-250	0.01-0.04	100-250	0.01-0.04	100-300	0.02-0.05			30-60	0.01-0.04
100-300	0.02-0.05	100-250	0.02-0.05	100-250	0.02-0.05	100-300	0.02-0.05			30-60	0.02-0.06
100-300	0.02-0.05	100-250	0.02-0.05	100-250	0.02-0.05	100-300	0.02-0.05	30-60	0.02-0.06	30-60	0.02-0.06
100-300	0.02-0.05	100-250	0.01-0.04	100-250	0.01-0.04	100-300	0.02-0.05			30-60	0.01-0.04
100-300	0.02-0.05	100-250	0.02-0.05	100-250	0.02-0.05	100-300	0.02-0.05			30-60	0.02-0.06
100-300	0.02-0.05	100-250	0.02-0.05	100-250	0.02-0.05	100-300	0.02-0.05	30-60	0.02-0.06	30-60	0.02-0.06



# CUT-LINE

Porte-outils

Halter

Holder

Ø max 34 mm

H Series

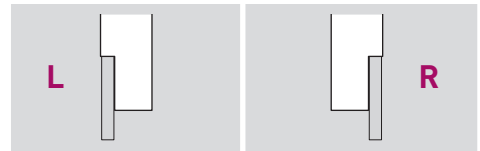
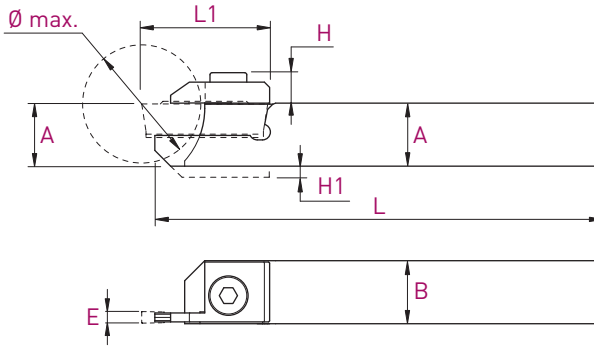

Plaquettes WSP Inserts	A x B	L	Ø max.	L1	H	H1	Art. N°	Art. N°
<b>E</b> 1.6 mm <b>Type</b> CUT16	8 x 10	115	16	19.5	6.2	2	CUT16-H0810L	CUT16-H0810R
	10 x 10	115	16	19.5	6.2	-	CUT16-H1010L	CUT16-H1010R
	12 x 12	130	16	19.5	6.2	-	CUT16-H1212L	CUT16-H1212R
	12 x 12	90	16	19.5	6.2	-	CUT16-H1212L-90	CUT16-H1212R-90
	12.7 x 12.7	130	16	19.5	6.2	-	CUT16-H127127L	CUT16-H127127R
	16 x 16	130	16	19.5	6.2	-	CUT16-H1616L	CUT16-H1616R
20 x 20	120	16	19.5	6.2	-	CUT16-H2020L	CUT16-H2020R	
<b>E</b> 2.2 mm <b>Type</b> CUT22	10 x 12	115	20	24	6.4	-	CUT22-H1012L	CUT22-H1012R
	12 x 12	130	20	24	6.4	-	CUT22-H1212L	CUT22-H1212R
	12 x 12	90	20	24	6.4	-	CUT22-H1212L-90	CUT22-H1212R-90
	12.7 x 12.7	130	20	24	6.4	-	CUT22-H127127L	CUT22-H127127R
	16 x 16	130	20	24	6.4	-	CUT22-H1616L	CUT22-H1616R
	20 x 20	120	20	24	6.4	-	CUT22-H2020L	CUT22-H2020R
<b>E</b> 3.1 mm <b>Type</b> CUT31	16 x 16	130	34	35	7.8	-	CUT31-H1616L	CUT31-H1616R
	20 x 20	120	34	35	7.8	-	CUT31-H2020L	CUT31-H2020R
	25 x 25	140	34	35	7.8	-	CUT31-H2525L	CUT31-H2525R

Pièces de rechange Ersatzteile Spare parts	L	R	Serrage Anzug Torque	
	Art. N°	Art. N°		Art. N°
CUT 16	CUT16L-SET	CUT16R-SET	V-M4X10-BN7	3.5 Nm
CUT 22	CUT22L-SET	CUT22R-SET	V-M4X10-BN7	3.5 Nm
CUT 31	CUT31L-SET	CUT31R-SET	V-M5X10-BN7	4.5 Nm

Porte-outils

Halter

Holders

Ø max 42 mm

HX Series

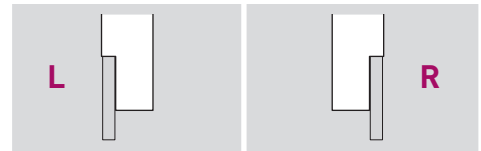
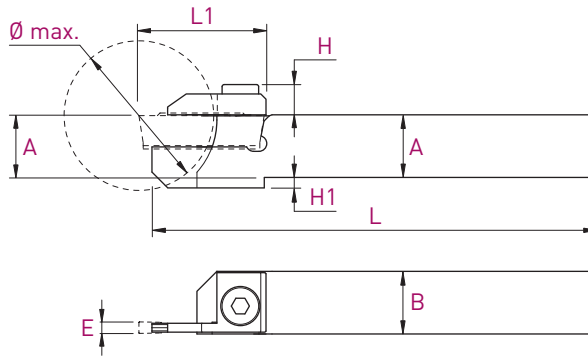

Plaquettes WSP Inserts	A x B	L	Ø max.	L1	H	H1	Art. N°	Art. N°
<b>E</b> 1.6 mm <b>Type</b> CUT16	10 x 12	115	20	21	6.2	2	CUT16-H1012LX	CUT16-H1012RX
	12 x 12	130	20	21	6.2	-	CUT16-H1212LX	CUT16-H1212RX
	12 x 12	90	20	21	6.2	-	CUT16-H1212LX-90	CUT16-H1212RX-90
	12.7 x 12.7	130	20	21	6.2	-	CUT16-H127127LX	CUT16-H127127RX
	16 x 16	130	20	21	6.2	-	CUT16-H1616LX	CUT16-H1616RX
	20 x 20	120	20	21	6.2	-	CUT16-H2020LX	CUT16-H2020RX
<b>E</b> 2.2 mm <b>Type</b> CUT22	10 x 12	115	26	25	6.4	4	CUT22-H1012LX	CUT22-H1012RX
	12 x 12	130	26	25	6.4	2	CUT22-H1212LX	CUT22-H1212RX
	12 x 12	90	26	25	6.4	2	CUT22-H1212LX-90	CUT22-H1212RX-90
	12.7 x 12.7	130	26	25	6.4	-	CUT22-H127127LX	CUT22-H127127RX
	16 x 16	130	26	25	6.4	-	CUT22-H1616LX	CUT22-H1616RX
	20 x 20	120	26	25	6.4	-	CUT22-H2020LX	CUT22-H2020RX
<b>E</b> 3.1 mm <b>Type</b> CUT31	16 x 16	120	42	37	7.8	4	CUT31-H1616LX	CUT31-H1616RX
	20 x 20	120	42	37	7.8	-	CUT31-H2020LX	CUT31-H2020RX
	25 x 25	140	42	37	7.8	-	CUT31-H2525LX	CUT31-H2525RX

Pièces de rechange Ersatzteile Spare parts	L	R		Serrage Anzug Torque
	Art. N°	Art. N°	Art. N°	
CUT 16	CUT16LX-SET	CUT16RX-SET	V-M4X10-BN7	3.5 Nm
CUT 22	CUT22LX-SET	CUT22RX-SET	V-M4X10-BN7	3.5 Nm
CUT 31	CUT31LX-SET	CUT31RX-SET	V-M5X10-BN7	4.5 Nm

# CUT-LINE

Porte-outils

Halter

Holders

Ø max 65 mm

HZ Series

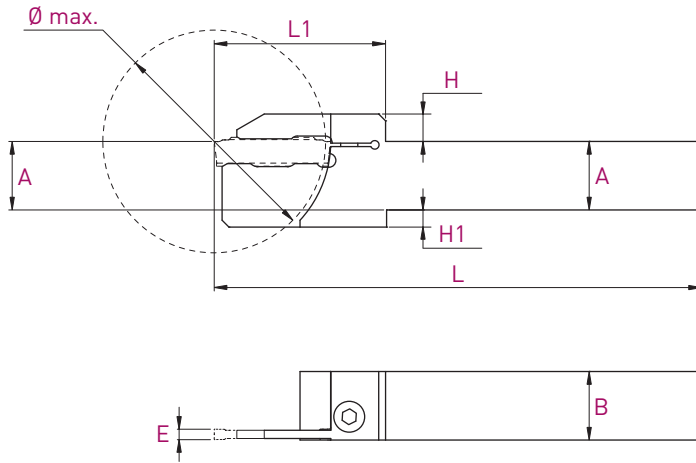

Plaquettes WSP Inserts	A x B	L	Ø max.	L1	H	H1	Art. N°	Art. N°
<b>E</b> 2.2 mm	16 x 16	130	32	30	7	-	CUT22-H1616LZ-D32	CUT22-H1616RZ-D32
	20 x 20	130	32	30	7	-	CUT22-H2020LZ-D32	CUT22-H2020RZ-D32
<b>Type</b> CUT22	16 x 16	130	42	35	7	4	CUT22-H1616LZ-D42	CUT22-H1616RZ-D42
	20 x 20	130	42	35	7	-	CUT22-H2020LZ-D42	CUT22-H2020RZ-D42
<b>E</b> 3.1 mm	20 x 20	140	52	44	8	5	CUT31-H2020LZ-D52	CUT31-H2020RZ-D52
	25 x 25	140	52	44	8	-	CUT31-H2525LZ-D52	CUT31-H2525RZ-D52
<b>Type</b> CUT31	20 x 20	140	65	50	8	5	CUT31-H2020LZ-D65	CUT31-H2020RZ-D65
	25 x 25	140	65	50	8	-	CUT31-H2525LZ-D65	CUT31-H2525RZ-D65

Pièces de rechange Ersatzteile Spare parts		Serrage Anzug Torque
	Art. N°	
CUT 22	V-M4X10-BN7	3.5 Nm
CUT 31	V-M5X10-BN7	4.5 Nm

Porte-outils avec arrosage intégré  
 Halter mit integrierter Kühlmittelzufuhr  
 Holders with integrated coolant supply

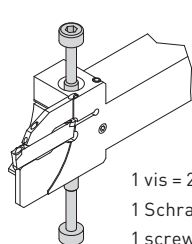
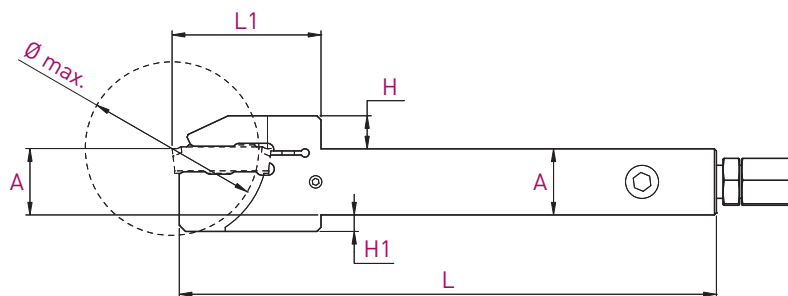

HZ-JET Series

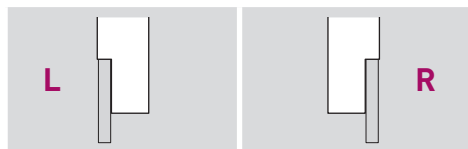
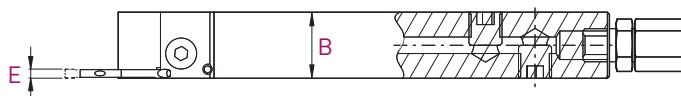

1 vis = 2 possibilités de serrage  
 1 Schraube = 2 Spannmöglichkeiten  
 1 screw = 2 clamp possibilities

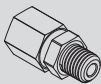

Plaquettes WSP Inserts	A x B	L	Ø max.	L1	H	H1	Art. N°	Art. N°
<b>E</b> 2.2 mm	16 x 16	130	42	36	8	4	CUT22-H1616LZ-JET42	CUT22-H1616RZ-JET42
<b>Type</b> CUT22	20 x 20	130	42	36	8	-	CUT22-H2020LZ-JET42	CUT22-H2020RZ-JET42
<b>E</b> 3.1 mm	16 x 16	140	65	49	9	9	CUT31-H1616LZ-JET65	CUT31-H1616RZ-JET65
<b>Type</b> CUT31	20 x 20	140	65	51	9	5	CUT31-H2020LZ-JET65	CUT31-H2020RZ-JET65
	25 x 25	140	65	51	9	-	CUT31-H2525LZ-JET65	CUT31-H2525RZ-JET65

Pièces de rechange Ersatzteile Spare parts		Serrage Anzug Torque		
	Art. N°		Art. N°	Art. N°
CUT 22	V-M4X22-CUT	3.5 Nm	J-M8X1-D6	JB-M8X1
CUT 31	V-M5X25-CUT	4.5 Nm	J-M8X1-D6	JB-M8X1

# CUT-LINE

Plaquettes de tronçonnage

Abstechwendeplatten

Cut off inserts

UN Series

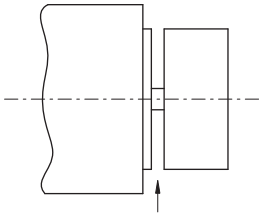
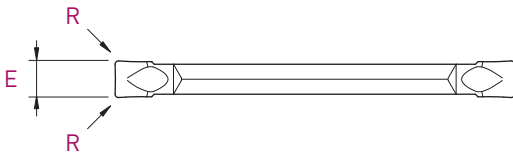
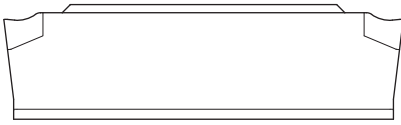

Type	E $\pm$ 0.1	R	Art. N°	TiAlN	Tmax	Zmax	HTA	AS
CUT16	1.6	0.02	CUT16-UN-000F	■			■	■
	1.6	0.10	CUT16-UN-001	■	■	■	■	■
CUT22	2.2	0.02	CUT22-UN-000F	■			■	■
	2.2	0.20	CUT22-UN-002	■	■	■	■	■
CUT31	3.1	0.02	CUT31-UN-000F	■			■	■
	3.1	0.20	CUT31-UN-002	■	■	■	■	■

Plaquettes de tronçonnage

Abstechwendeplatten

Cut off inserts

UL-UR Series

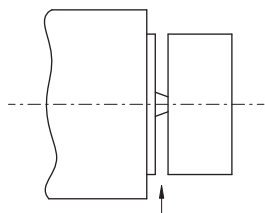
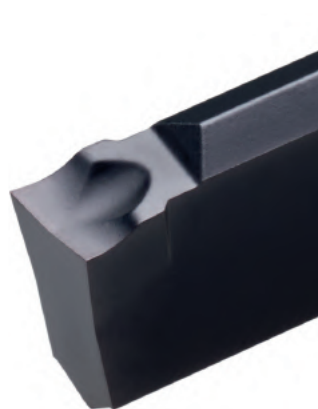
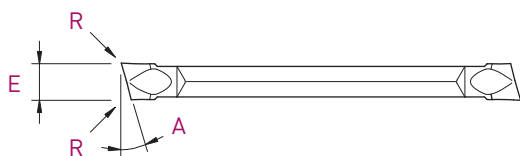
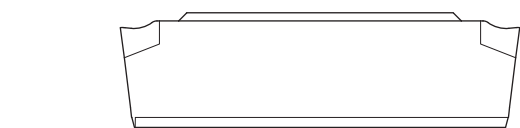

				UL			UR						
Type	E ±0.1	A	R	Art. N°	TiAlN	HTA	AS	Art. N°	TiAlN	Tmax	Zmax	HTA	AS
CUT16	1.6	8°	0.02	CUT16-UL-800F	■	■	■	CUT16-UR-800F	■			■	■
	1.6	15°	0.02	CUT16-UL-1500F	■	■	■	CUT16-UR-1500F	■			■	■
CUT22	2.2	8°	0.02	CUT22-UL-800F	■	■	■	CUT22-UR-800F	■			■	■
	2.2	8°	0.20	-				CUT22-UR-802		■	■		
	2.2	8°	0.20	CUT22-UL-802F	■	■	■	CUT22-UR-802F	■			■	■
	2.2	15°	0.02	CUT22-UL-1500F	■	■	■	CUT22-UR-1500F	■			■	■
CUT31	3.1	8°	0.02	CUT31-UL-800F	■	■	■	CUT31-UR-800F	■			■	■
	3.1	8°	0.20	CUT31-UL-802F	■	■	■	CUT31-UR-802F	■			■	■
	3.1	15°	0.02	CUT31-UL-1500F	■	■	■	CUT31-UR-1500F	■			■	■

# CUT-LINE

Plaquettes de tronçonnage

Abstechwendeplatten

Cut off inserts

PN Series

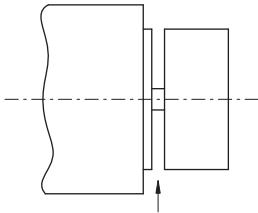
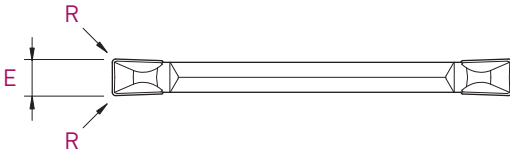
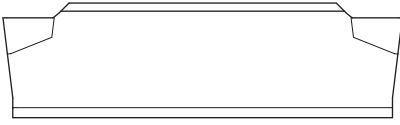

Type	E ±0.1	R	Art. N°	TrAIN	Tmax
CUT22	2.2	0.20	CUT22-PN-002	■	■
CUT31	3.1	0.20	CUT31-PN-002	■	■



Plaquettes de tronçonnage

Abstechwendeplatten

Cut off inserts

## PR Series

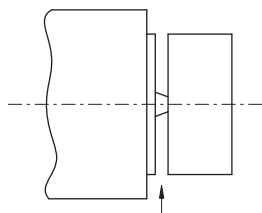
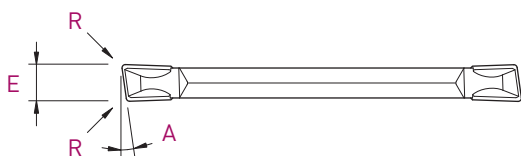
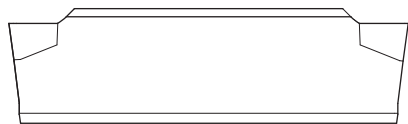

Type	E ±0.1	A	R	Art. N°	TiAlN	Tmax
CUT16	1.6	8°	0.10	CUT16-PR-801	■	■
CUT22	2.2	8°	0.20	CUT22-PR-802	■	■
CUT31	3.1	8°	0.20	CUT31-PR-802	■	■

# CUT-LINE

Plaquettes de tronçonnage  
 Abstechwendeplatten  
 Cut off inserts

PNW Series

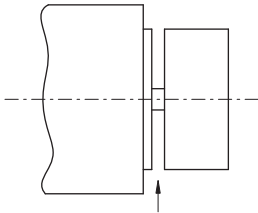
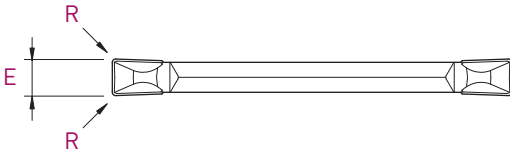
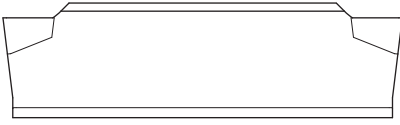

Type	E ±0.1	R	Art. N°	Z
CUT22	2.2	0.20	CUT22-PNW-002	■
CUT31	3.1	0.20	CUT31-PNW-002	■

Plaquettes de tronçonnage

Abstechwendeplatten

Cut off inserts

PRW Series

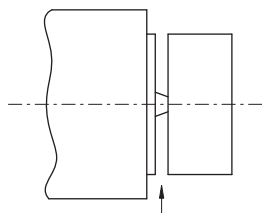
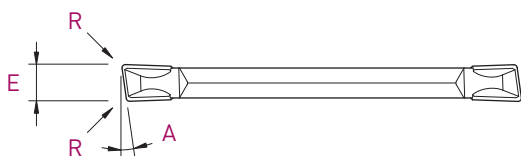
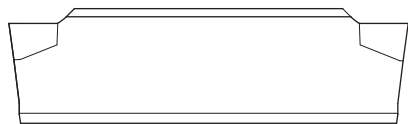

PRW



Type	E ±0.1	A	R	Art. N°	z
CUT16	1.6	8°	0.10	CUT16-PRW-801	■
CUT22	2.2	8°	0.20	CUT22-PRW-802	■
CUT31	3.1	8°	0.20	CUT31-PRW-802	■

# CUT-LINE

Plaquettes de tronçonnage  
 Abstechwendeplatten  
 Cut off inserts

Negative geometry

TN Series

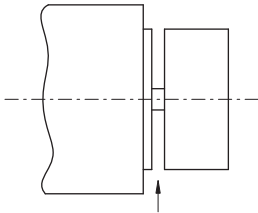
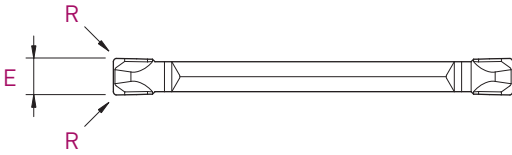
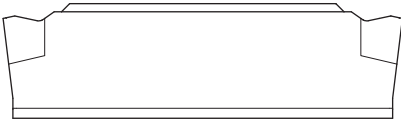

Type	E ±0.1	R	Art. N°	TiAlN	Tmax	Zmax
CUT22	2.2	0.20	CUT22-TN-002	■	■	■
CUT31	3.1	0.20	CUT31-TN-002	■	■	■

Plaquettes de fonçage, tournage et tronçonnage  
 WSP zum einstecken, drehen und abstechen  
 Solid carbide inserts for grooving, turning and cut off

## GN Series

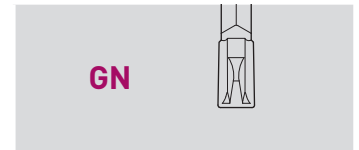
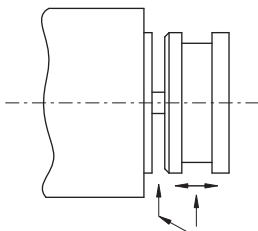
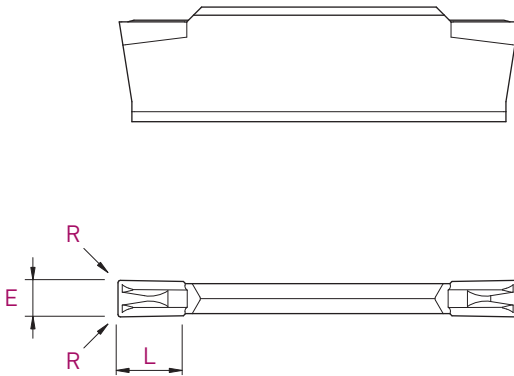

Type	E ±0.1	L	R	Art. N°	TiAlN	Tmax	AS
CUT22	2.2	3.5	0.15	CUT22-GN-002	■	■	■
CUT31	3.1	5.0	0.15	CUT31-GN-002	■	■	■

Conseils d'utilisation pour plaquettes type GN  
 Anwendungsempfehlungen für GN-Wendeleplatten  
 Application recommendations for GN inserts

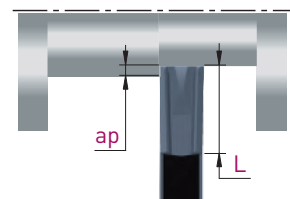
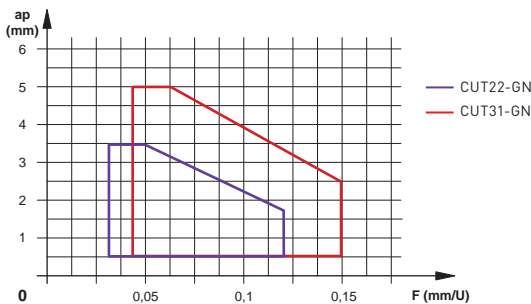

$a_p \text{ max} = T$  dans matière à bonne usinabilité  
 $a_p \text{ max} = T$  in Werkstoffe mit gute Zerspanbarkeit  
 $a_p \text{ max} = T$  in material with good machinability

**BH**

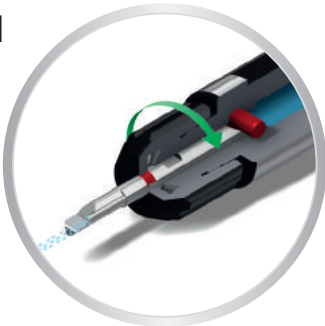

**BHS**

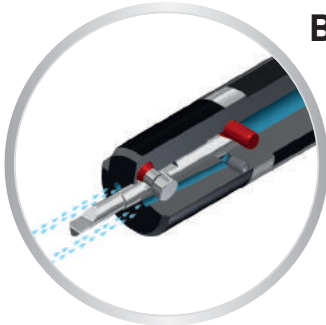

**BHY**

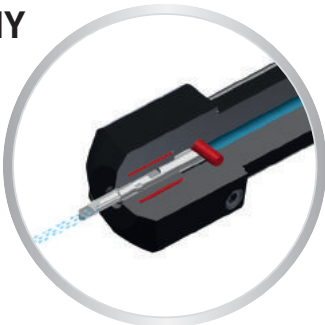

**BHK**

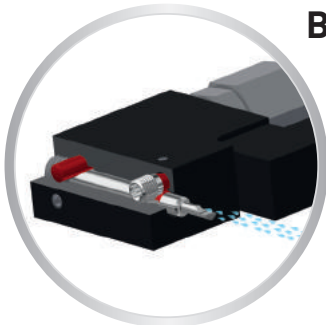

Système de désignation  
Bezeichnungssystem  
Designation system **Info** > **10.02**

Nuances & paramètres de coupe  
Sorten & Schnittwerte  
Grades & machining data > **10.08**

Porte-outils  
Halter  
Holders **BH / BHS / BHY / BHK** > **10.10**

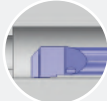
Alésage  
Ausbohren  
Boring **BA / BAX**  > **10.20**

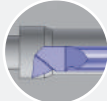
Alésage-copiage  
Ausbohren-kopieren  
Boring chambering **BCX**  > **10.24**

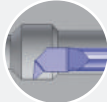
Copiage  
Kopieren  
Chambering **C45 / C45X**  > **10.26**

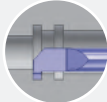
Gorge  
Einstechen  
Grooving **GX**  > **10.30**

Fonçage-tournage  
Einstechen und drehen  
Grooving and turning **GTX**  > **10.32**

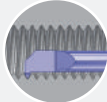
Filetage  
Gewindedrehen  
Threading **TP60° / TP55° / TM**  > **10.34**

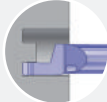
Gorge frontale  
Axiales Stechen  
Axial grooving **FEG / FIG**   > **10.40**

Ébauches / Jauges d'alignement / Adaptations machines / Accessoires  
Rohlinge / Richtplatten / Maschinenanpassungen / Zubehöre  
Blanks / Adjusting tools / Machines adapters / Accessories > **10.42**





Système de désignation des porte-outils

Halter Bezeichnungssystem

Holders designation system

BHK

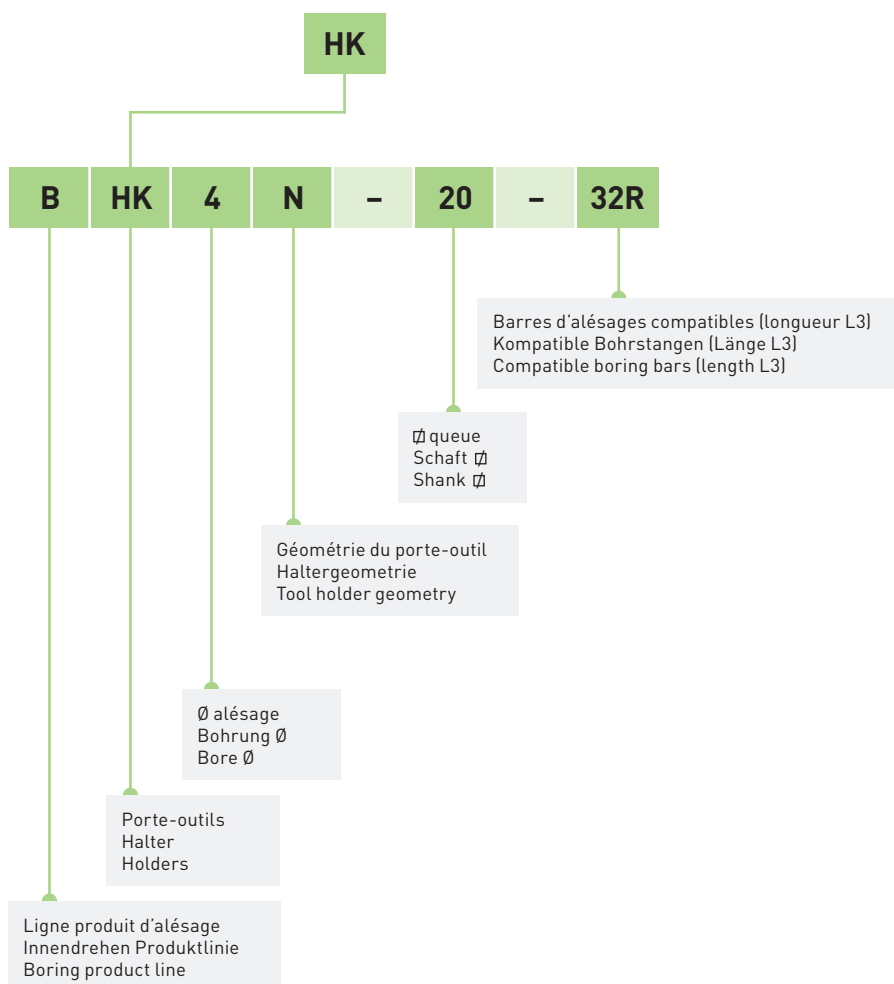
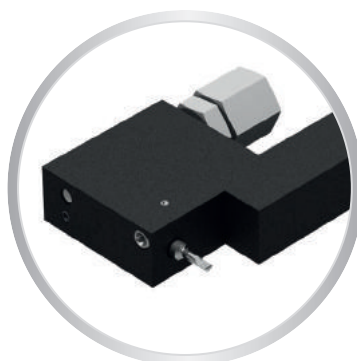

Système de désignation des barres d'alésage

Bohrstangen Bezeichnungssystem

Boring bars designation system

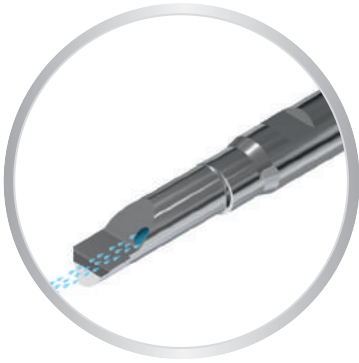

**B**

**F**

**B B 4 R - 25 - 75 - BAX - R05 - ZN**

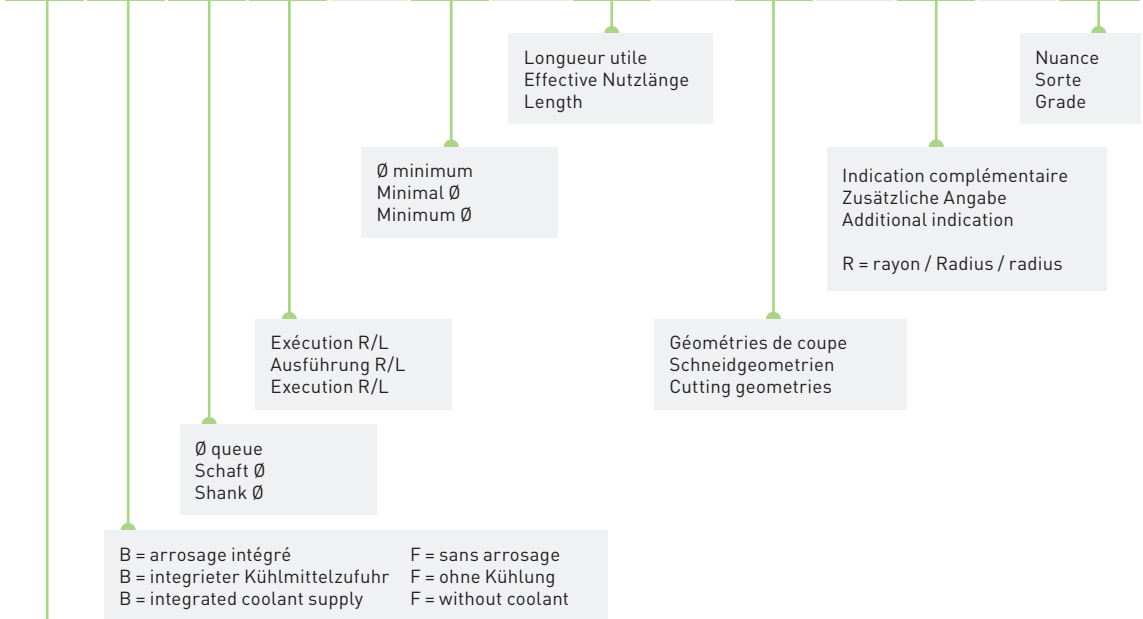

Porte-outils avec écrou de serrage

Halter mit Spannmutter

Tool holders with clamping nut

BH-D

Arrosage par la barre d'alésage

Kühlung durch die Bohrstange

Cooling through the boring bar

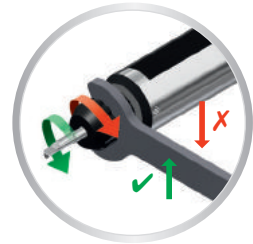
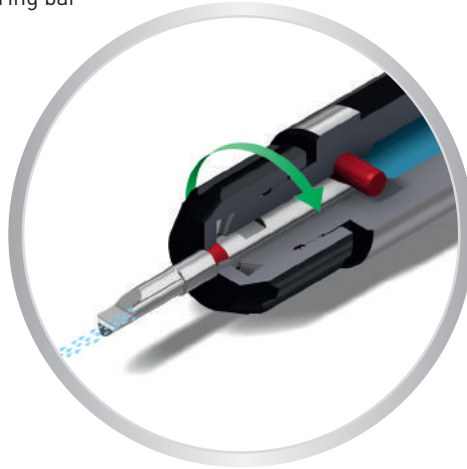

Porte-outils avec arrosage multiple

Halter mit mehrfaches Kühlungssystem

Tool holders with multiple coolant system

BHS-D

Système de serrage à vis transversale

Querverschraubungssystem

Clamping system with transverse screw

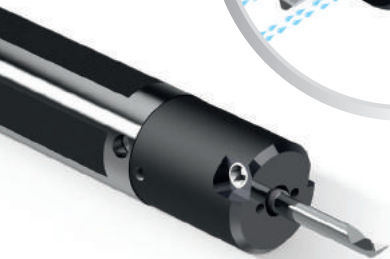
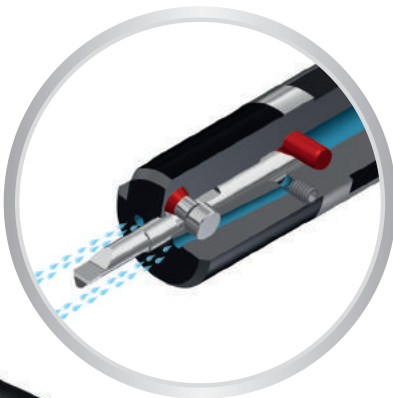

Arrosage sur l'arête de coupe

Kühlung auf der Schneidkante

Cooling on the cutting edge

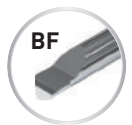
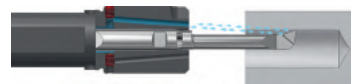

Arrosage favorisant l'évacuation des copeaux

Spanabfuhr fördernde Kühlung

Cooling for better chip outflow

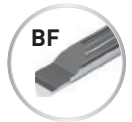
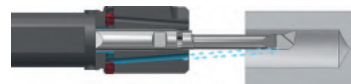

Arrosage par le centre de l'outil

Zentrale Kühlmittelzufuhr

Cooling through the center of the tool

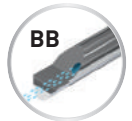

## IN-LINE

- Porte-outils à serrage hydraulique
- Halter mit Hydro-Dehnspann-System
- Tool holders with hydraulic clamping system

BHY



Excellente absorption des vibrations!  
Ausgezeichnete Schwingungsdämpfung!  
Excellent vibration absorption!

Arrosage par la barre d'alésage  
Kühlung durch die Bohrstange  
Cooling through the boring bar

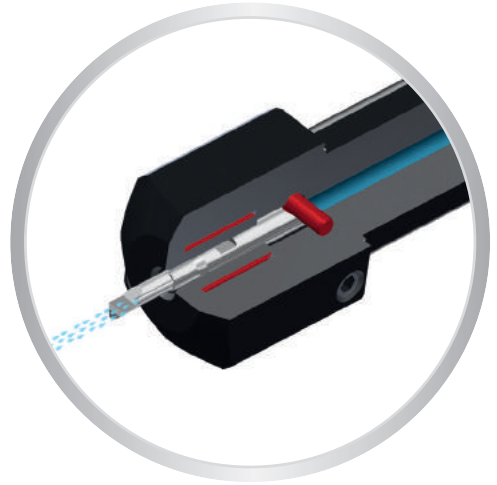

- Porte-outils coudés
- Gekröpfte Halter
- Cranked tool holders

BHK

Système de serrage à vis transversale  
Querverschraubungssystem  
Clamping system with transverse screw

Arrosage par la barre d'alésage  
Kühlung durch die Bohrstange  
Cooling through the boring bar

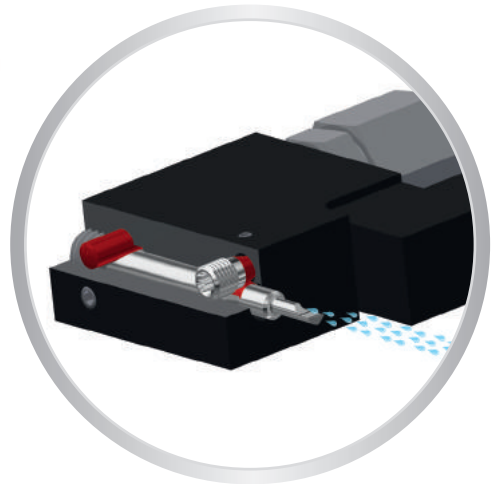
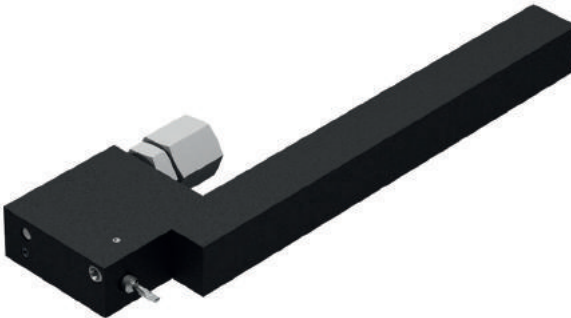

Accessoires de serrage

Spannzubehöre

Clamping accessories

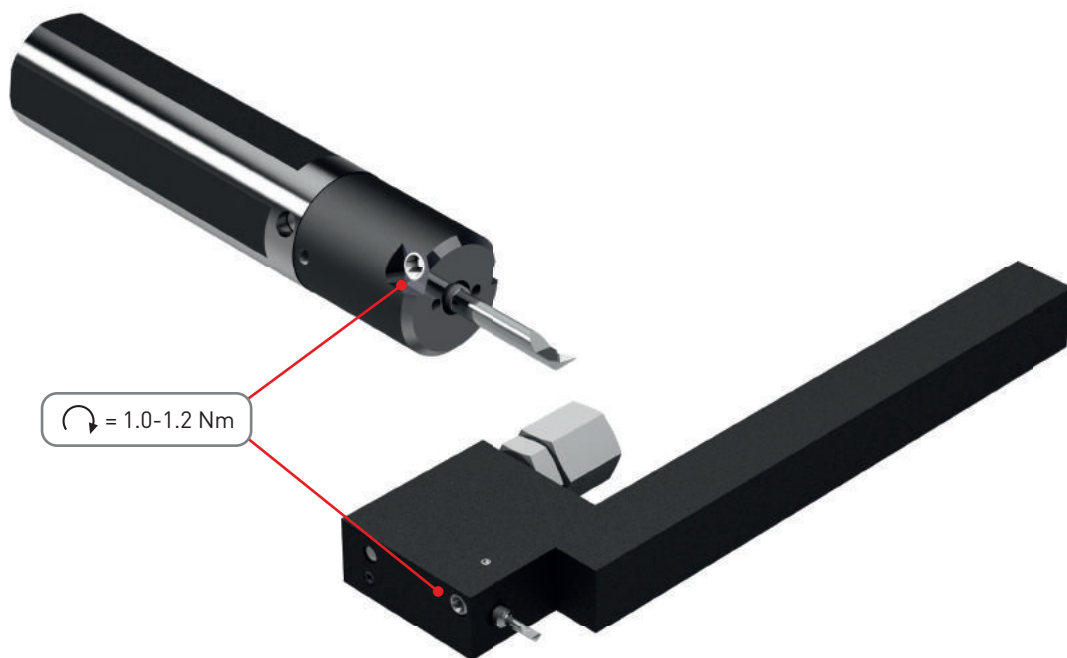

Nous recommandons le serrage des porte-outils types BHS et BHK avec ce type de tournevis dynamométrique.

Wir empfehlen für das Anziehen der Halter Typ BHS und BHK diese Art von Drehmomentschraubendreher.

For holders type BHS and BHK clamping, we recommend this kind of torque screwdriver.



Art. N°

SET-NM1.2-TX8

Nuances

Sorten

Grades

**P**

**M**

**N**

**S**

## ZTAF

ZN + revêtement PVD  
ZN + PVD Beschichtung  
ZN + PVD coating

- nuance universelle pour l'usinage des aciers, aciers inoxydables, aciers alliés, alliage de titane
- bonne résistance à la température

- Universalsorte für die Bearbeitung von Stahl, rostfreiem Stahl, Stahllegierung, Titanlegierung
- gute Warmfestigkeit

- universal grade for steel, stainless steel, alloyed steel, titanium alloys
- good heat resistance

**P**

**M**

**S**

## ZTAXF

ZN + revêtement PVD  
ZN + PVD Beschichtung  
ZN + PVD coating

- nuance très résistante à l'usure et à la température, recommandée pour l'usinage des matières suivantes: Inox 304, 316L, 317L, 904, Phynox
- aciers alliés contenant: Chrome Nickel, Vanadium, Molybdène, ...

- sehr verschleissfeste und temperaturbeständige Sorte. Für folgende Materialien empfohlen: Inox 304, 316L, 317L, 904, Phynox
- legierter Stahl enthaltend: Chrom-Nickel, Vanadium, Molybdän, ...

- very wear and high temperature resistant grade. Recommended for following material: Inox 304, 316L, 317L, 904, Phynox
- alloy steel containing: Chrome-nickel, Vanadium, Molybdenum, ...

**P**

**N**

**S**

## ZN

non revêtu  
unbeschichtet  
uncoated

- nuance de base micro-grain tenace
- 1<sup>er</sup> choix pour l'usinage des métaux non ferreux

- zähe Basis Feinkornsorte
- beste Wahl für die Bearbeitung von Nichteisenmetalle

- tough base micro-grain grade
- first choice for non-ferrous materials

## Paramètres de coupe

## Schnittwerte

## Machining data

Matière Werkstoff Material	VC (m/min)	Ø barre d'alésage Bohrstange Ø boring bar Ø		
		Ø1.0 - Ø2.0 (mm/U)	Ø2.5 - Ø4.0 (mm/U)	Ø4.5 - Ø5.5 (mm/U)
Acier de décolletage Automatenstahl Free-cutting steel (P)	60-100	0.02-0.03	0.02-0.08	0.03-0.10
Acier faiblement allié Leicht legierter Stahl Low alloyed steel (P)	50-80	0.01-0.03	0.02-0.05	0.03-0.06
Acier fortement allié Legierter Stahl High alloyed steel (P)	40-60	0.01-0.02	0.02-0.04	0.02-0.06
Acier inoxydable Rostfreistahl Stainless steel (M)	40-90	0.01-0.03	0.02-0.05	0.03-0.08
Aluminium (N)	60-150	0.01-0.03	0.02-0.06	0.03-0.10
Cuivre, laiton, bronze Kupfer, Messing, Bronze Copper, brass, bronze (N)	60-150	0.01-0.03	0.02-0.05	0.03-0.08
Titane Titan Titanium (S)	30-70	0.01-0.03	0.02-0.05	0.03-0.10

Porte-outils avec écrou de serrage

Halter mit Spannmutter

Tool holders with clamping nut

## BH4-D

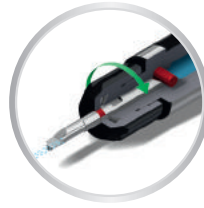

> page 10.05

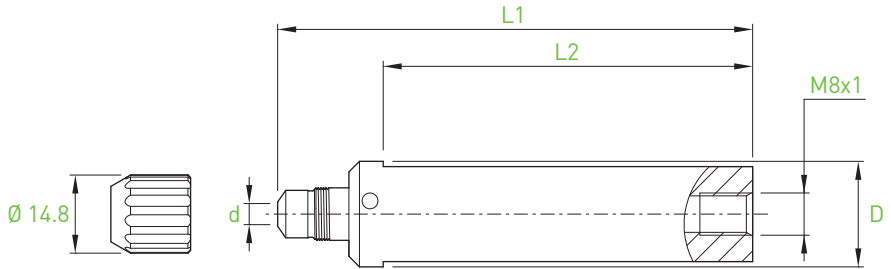
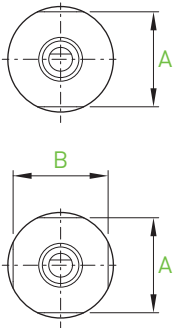

d	Bars	D	L1	L2	A x B	2 flats	4 flats	Art. N°
4	BB4... BF4...	10	75	55	8.8x8.8	■		BH4-D10-75
		12	75	55	11.2x11.2	■		BH4-D12-75
		12.7	75	55	11.2x11.2	■		BH4-D12.7-75
		15.87	75	55	14x14	■		BH4-D15.87-75
		16	75	55	14x14	■		BH4-D16-75
		16	75	55	14x14		■	BH4-D16-75-F4
		19.05	90	70	17x17	■		BH4-D19.05-90
		20	90	70	18x18	■		BH4-D20-90
		20	90	70	18x18		■	BH4-D20-90-F4
		20	160	140	18x18		■	BH4-D20-160-F4
		22	90	70	20x20	■		BH4-D22-90
		22	90	70	20x20		■	BH4-D22-90-F4
		22	130	110	20x20		■	BH4-D22-130-F4
		25	100	80	23x23	■		BH4-D25-100
		25	100	80	23x23		■	BH4-D25-100-F4
		25	170	150	23x23		■	BH4-D25-170-F4
25.4	100	80	23.4x23.4	■		BH4-D25.4-100		
28	100	80	26x26	■		BH4-D28-100		

Pièces de rechange  
Ersatzteile  
Spare parts



Art. N°



Art. N°

BH4...

BH4-M10

C-BH4-M10

Option

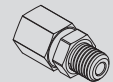

Art. N°

BH4...

J-M8X1-D6

more option  
see JET-Line



Porte-outils avec écrou de serrage

Halter mit Spannmutter

Tool holders with clamping nut

BH6-D



> page 10.05

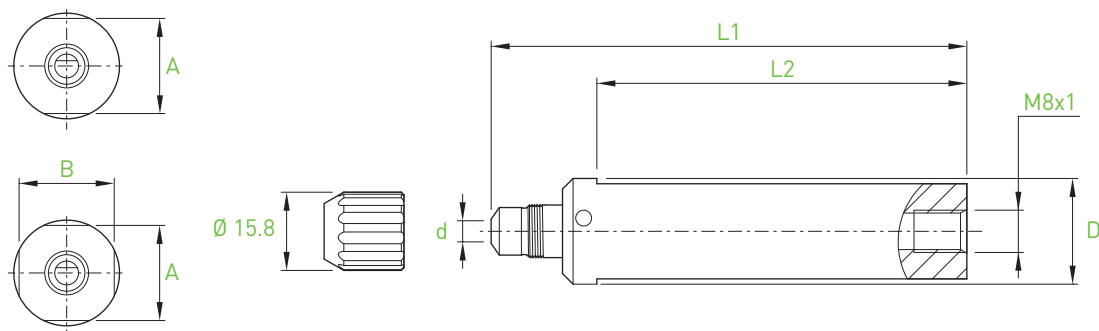

d	Bars	D	L1	L2	A x B	2 flats	4 flats	Art. N°
6	BB6... BF6...	12	75	55	11.2x11.2	■		BH6-D12-75
		12.7	75	55	11.2x11.2	■		BH6-D12.7-75
		15.87	75	55	14x14	■		BH6-D15.87-75
		16	75	55	14x14	■		BH6-D16-75
		19.05	90	70	17x17	■		BH6-D19.05-90
		20	90	70	18x18	■		BH6-D20-90
		20	90	70	18x18		■	BH6-D20-90-F4
		20	160	140	18x18		■	BH6-D20-160-F4
		22	90	70	20x20	■		BH6-D22-90
		22	90	70	20x20		■	BH6-D22-90-F4
		22	130	110	20x20		■	BH6-D22-130-F4
		25	100	80	23x23	■		BH6-D25-100
		25	100	80	23x23		■	BH6-D25-100-F4
		25	170	150	23x23		■	BH6-D25-170-F4
		25.4	100	80	23.4x23.4	■		BH6-D25.4-100
28	100	80	26x26	■		BH6-D28-100		

Pièces de rechange  
Ersatzteile  
Spare parts



Art. N°

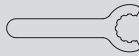

Art. N°

BH6...

BH6-M12

C-BH6-M12

Option

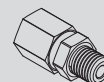

Art. N°

BH6...

J-M8X1-D6

more option  
see JET-Line

■ = disponible / verfügbar / available

□ = selon disponibilité du stock / jenach Lagerverfügbarkeit / depending the stock availability

Porte-outils avec arrosage multiple  
 Halter mit mehrfaches Kühlungssystem  
 Tool holders with multiple coolant system

## BHS4-D

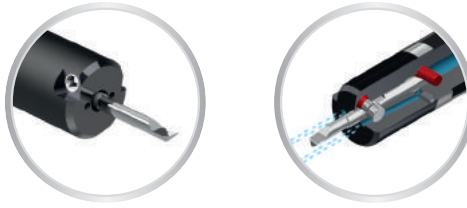

> page 10.05/10.07

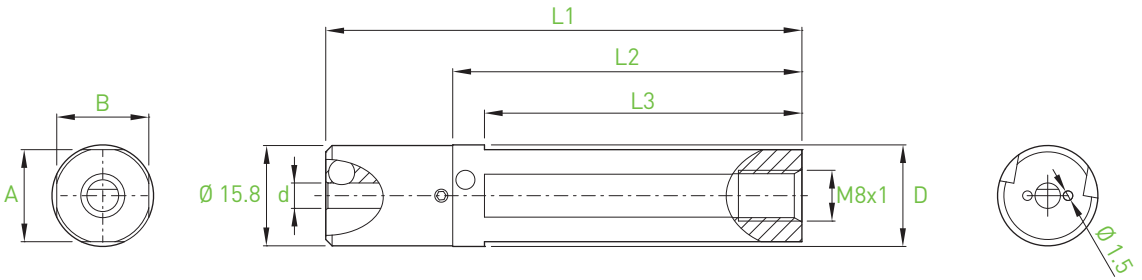

d	Bars	D	L1	L2	L3	A x B	Art. N°
4	BB4... BF4...	10	75	55	50	9.2x9.2	BHS4-D10-75-F4
		12	75	55	50	11x11	BHS4-D12-75-F4
		12.7	75	55	50	11.7x11.7	BHS4-D12.7-75-F4
		15.87	75	55	50	14.5x14.5	BHS4-D15.87-75-F4
		16	75	55	50	14.5x14.5	BHS4-D16-75-F4
		16	110	90	85	14.5x14.5	BHS4-D16-110-F4
		19.05	90	70	65	17x17	BHS4-D19.05-90-F4
		20	90	70	65	18x18	BHS4-D20-90-F4
		20	160	140	135	18x18	BHS4-D20-160-F4
		22	90	70	65	20x20	BHS4-D22-90-F4
		22	130	110	105	20x20	BHS4-D22-130-F4
		25	100	80	75	23x23	BHS4-D25-100-F4
		25	170	150	145	23x23	BHS4-D25-170-F4
		25.4	100	80	75	23x23	BHS4-D25.4-100-F4
28	100	80	75	26x26	BHS4-D28-100-F4		

Pièces de rechange  
 Ersatzteile  
 Spare parts

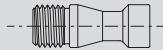

Art. N°



Art. N°

BHS4...

V-BHS-M4X0.5-T8

C-T8

Option

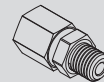

Art. N°



Art. N°

BHS4...

J-M8X1-D6

SET-NM1.2-TX8

more option  
 see JET-Line

Porte-outils avec arrosage multiple  
 Halter mit mehrfaches Kühlungssystem  
 Tool holders with multiple coolant system

BHS6-D

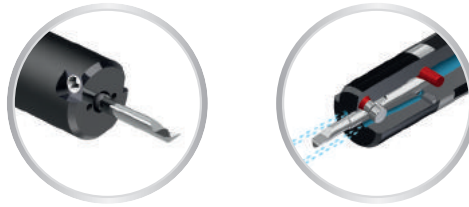

> page 10.05/10.07

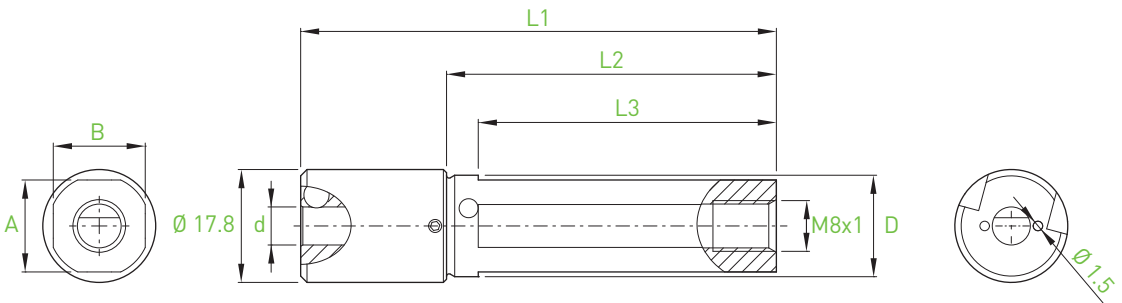

d	Bars	D	L1	L2	L3	A x B	Art. N°
6	BB6... BF6...	12	75	52	47	11x11	BHS6-D12-75-F4
		12.7	75	52	47	11.7x11.7	BHS6-D12.7-75-F4
		15.87	75	52	47	14.5x14.5	BHS6-D15.87-75-F4
		16	75	52	47	14.5x14.5	BHS6-D16-75-F4
		16	110	87	82	14.5x14.5	BHS6-D16-110-F4
		19.05	90	67	62	17x17	BHS6-D19.05-90-F4
		20	90	67	62	18x18	BHS6-D20-90-F4
		20	160	137	132	18x18	BHS6-D20-160-F4
		22	90	67	62	20x20	BHS6-D22-90-F4
		22	130	107	102	20x20	BHS6-D22-130-F4
		25	100	77	72	23x23	BHS6-D25-100-F4
		25	170	147	142	23x23	BHS6-D25-170-F4
		25.4	100	77	72	23x23	BHS6-D25.4-100-F4
28	100	77	72	26x26	BHS6-D28-100-F4		

Pièces de rechange  
 Ersatzteile  
 Spare parts

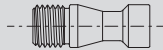

Art. N°

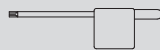

Art. N°

BHS6...

V-BHS-M4X0.5-T8

C-T8

Option

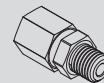

Art. N°



Art. N°

BHS6...

J-M8X1-D6

SET-NM1.2-TX8

more option  
 see JET-Line

Porte-outils à serrage hydraulique  
 Halter mit Hydro-Dehnspann-System  
 Tool holders with hydraulic clamping system

## BHY4-D



> page 10.06

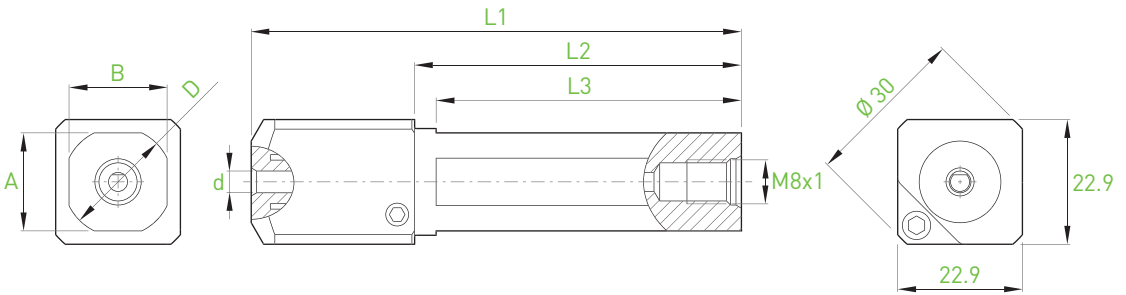

d	Bars	D	L1	L2	L3	A x B	Art. N°
4	BB4... BF4...	12	90	60	55	11.2x11.2	BHY4-D12-90-F4
		16	90	60	55	14.5x14.5	BHY4-D16-90-F4
		19.05	90	60	55	17x17	BHY4-D19.05-90-F4
		20	90	60	55	18x18	BHY4-D20-90-F4
		22	90	60	55	20x20	BHY4-D22-90-F4
		25	100	70	65	23x23	BHY4-D25-100-F4

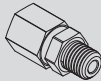
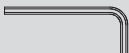
Pièces de rechange Ersatzteile Spare parts	 Art. N°	 Art. N°
BHY4...	<b>J-M8X1-D6</b> more option see JET-Line	<b>C-6P-3.0</b>

Porte-outils à serrage hydraulique  
 Halter mit Hydro-Dehnspann-System  
 Tool holders with hydraulic clamping system

BHY6-D

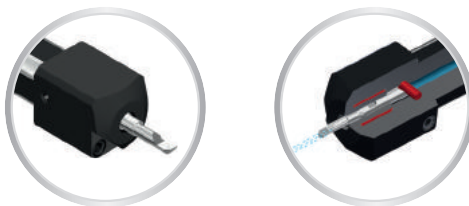

> page 10.06

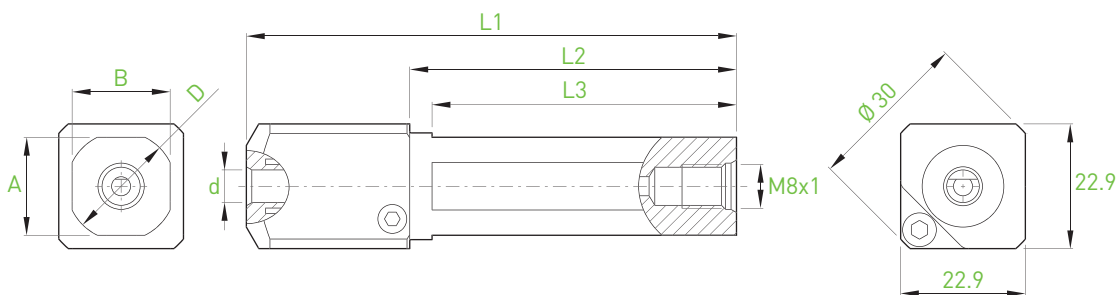

d	Bars	D	L1	L2	L3	A x B	Art. N°
6	BB6... BF6...	12	90	60	55	11.2x11.2	BHY6-D12-90-F4
		16	90	60	55	14.5x14.5	BHY6-D16-90-F4
		19.05	90	60	55	17x17	BHY6-D19.05-90-F4
		20	90	60	55	18x18	BHY6-D20-90-F4
		22	90	60	55	20x20	BHY6-D22-90-F4
		25	100	70	65	23x23	BHY6-D25-100-F4

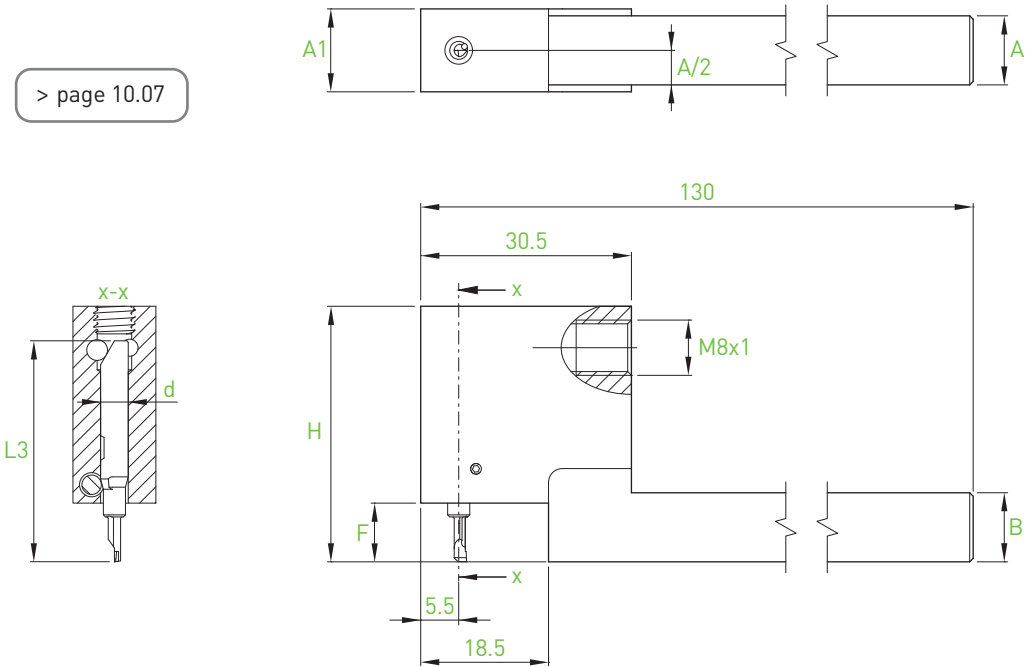

Pièces de rechange Ersatzteile Spare parts		
BHY6...	Art. N° <b>J-M8X1-D6</b> more option see JET-Line	Art. N° <b>C-6P-3.0</b>

> page 10.07

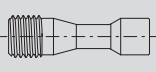
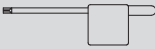

d	Bars	L3	A x B	F	H	A1	Art. N°
4	BB4R... BF4R...	32	8x8	8.5	37	12	BHK4N-0808X-32R
			10x10	8.5	37	12	BHK4N-1010X-32R
			12x12	8.5	37	12	BHK4N-1212X-32R
			16x16	8.5	37	16	BHK4N-1616X-32R
		37	8x8	13.5	42	12	BHK4N-0808X-37R
			10x10	13.5	42	12	BHK4N-1010X-37R
			12x12	13.5	42	12	BHK4N-1212X-37R
			16x16	13.5	42	16	BHK4N-1616X-37R
		42	10x10	18.5	47	12	BHK4N-1010X-42R
			12x12	18.5	47	12	BHK4N-1212X-42R
			16x16	18.5	47	16	BHK4N-1616X-42R

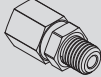
Pièces de rechange Ersatzteile Spare parts		
	Art. N°	Art. N°
BHK4N...	V-BHK-M4X0.5-T8	C-T8

Option		
	Art. N°	Art. N°
BHK4N...	J-M8X1-D6	SET-NM1.2-TX8
	more option see JET-Line	

Porte-outils coudés

Kröpfunghalter

Cranked tool holders

BHK6N

> page 10.07

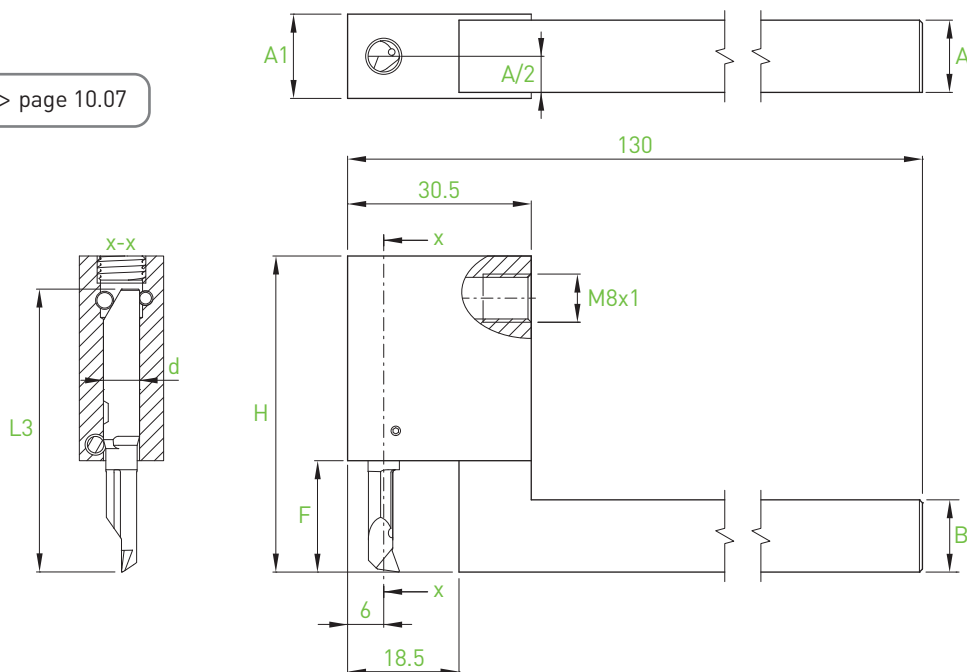

d	Bars	L3	A x B	F	H	A1	Art. N°
6	BB6R... BF6R...	47	10x10	18.5	52.5	12	BHK6N-1010X-47R
			12x12	18.5	52.5	12	BHK6N-1212X-47R
			16x16	18.5	52.5	16	BHK6N-1616X-47R
		57	10x10	28.5	62.5	12	BHK6N-1010X-57R
			12x12	28.5	62.5	12	BHK6N-1212X-57R
			16x16	28.5	62.5	16	BHK6N-1616X-57R

Pièces de rechange  
Ersatzteile  
Spare parts

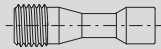

Art. N°



Art. N°

BHK6N...

V-BHK-M4X0.5-T8

C-T8

Option

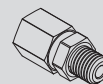

Art. N°



Art. N°

BHK6N...

J-M8X1-D6

SET-NM1.2-TX8

more option  
see JET-Line

# IN-LINE

Porte-outils section carrée  
 Viereckige Halter  
 Square holders

**BHS4**

**new**

> page 10.07

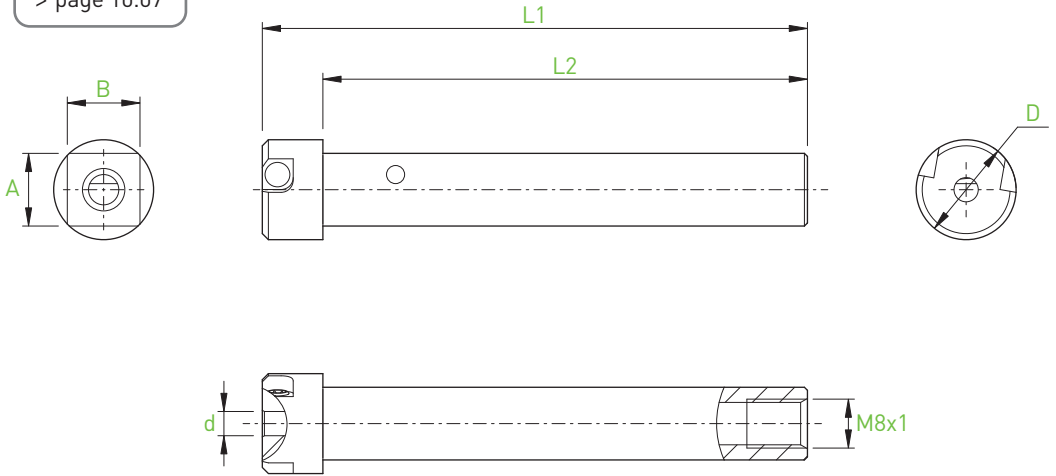

d	Bars	A x B	L1	L2	D	Art. N°
4	BB4... BF4...	12x12	90	80	16.5	<b>BHS4-1212-90</b>
		16x16	100	90	15.5	<b>BHS4-1616-90</b>

Pièces de rechange  
 Ersatzteile  
 Spare parts

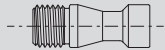

Art. N°



Art. N°

BHS4...

**V-BHS-M4X0.5-T8**

**C-T8**

Option

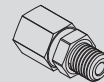

Art. N°



Art. N°

BHS4...

**J-M8X1-D6**

**SET-NM1.2-TX8**

more option  
 see JET-Line



Porte-outils section carrée

Viereckige Halter

Square holders

BHS6

**new**

> page 10.05

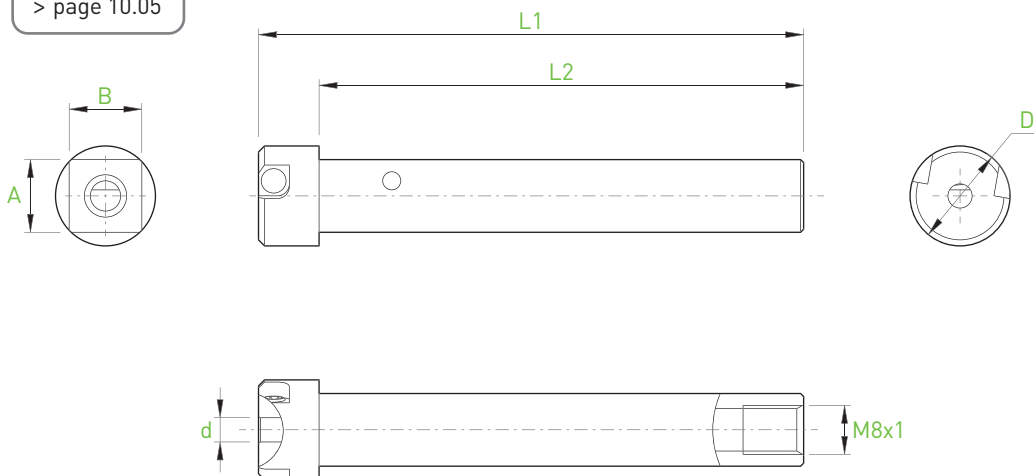

d	Bars	A x B	L1	L2	D	Art. N°
6	BB6... BF6...	12x12 16x16	90 100	80 -	17.5 -	BHS6-1212-90 BHS6-1616-90

Pièces de rechange  
Ersatzteile  
Spare parts

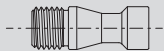

Art. N°

BHS6...

V-BHS-M4X0.5-T8

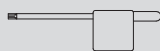

Art. N°

C-T8

Option

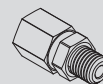

Art. N°

BHS6...

J-M8X1-D6

more option  
see JET-Line



Art. N°

SET-NM1.2-TX8

# IN-LINE

Alésage  
Ausbohren  
Boring

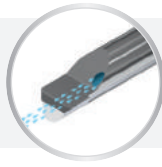

BB4...

BA

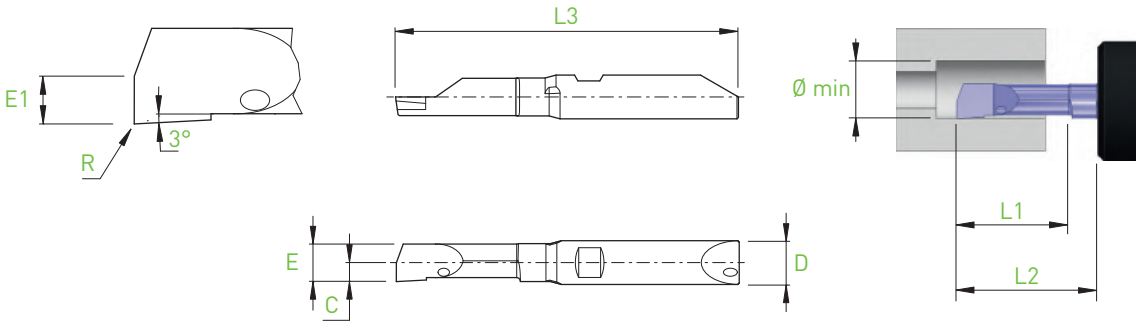

D h5	Holder	Ø min	L1	L2 BH4... BHY4...	L2 BHS4... BHK4...	E	E1	C	R	L3	Art. N°	R			L		
												ZTAF	ZTAXF	ZN	ZTAF	ZTAXF	ZN
4	BH4... BHS4... BHY4... BHK4...	0.3	0.9	10	8.5	0.27	0.13	0.15	0	32	BB4R/L-0309-BA	■	■	■	□	□	□
		0.4	1.2	10	8.5	0.36	0.18	0.20	0	32	BB4R/L-0412-BA	■	■	■	□	□	□
		0.5	1.5	10	8.5	0.45	0.22	0.25	0	32	BB4R/L-0515-BA	■	■	■	□	□	□
		0.6	1.8	10	8.5	0.54	0.27	0.30	0	32	BB4R/L-0618-BA	■	■	■	□	□	new
		0.7	2.1	10	8.5	0.63	0.31	0.35	0	32	BB4R/L-0721-BA	■	■	■	□	□	new
		0.8	2.4	10	8.5	0.72	0.36	0.40	0	32	BB4R/L-0824-BA	■	■	■	□	□	new
		0.9	2.7	10	8.5	0.81	0.40	0.45	0	32	BB4R/L-0927-BA	■	■	■	□	□	new
		1.0	3.0	10	8.5	0.90	0.45	0.60	0.02	32	BB4R/L-1030-BA-R02	■	■	■	□	□	
		1.2	3.6	10	8.5	1.08	0.54	0.60	0.02	32	BB4R/L-1236-BA-R02	■	■	■	□	□	new
		1.5	4.5	10	8.5	1.35	0.67	0.65	0.02	32	BB4R/L-1545-BA-R02	■	■	■	□	□	
		2.0	6.0	10	8.5	1.80	0.90	1.15	0.02	32	BB4R/L-2060-BA-R02	■	■	■	□	□	
		2.5	7.5	10	8.5	2.25	1.13	1.30	0.02	32	BB4R/L-2575-BA-R02	■	■	■	□	□	
		3.0	9.0	15	13.5	2.70	1.35	1.35	0.05	37	BB4R/L-3090-BA-R05	■	■	■	□	□	
3.5	10.5	15	13.5	3.15	1.58	1.60	0.05	37	BB4R/L-35105-BA-R05	■	■	■	□	□			

Alésage  
Ausbohren  
Boring



BF4...

BA

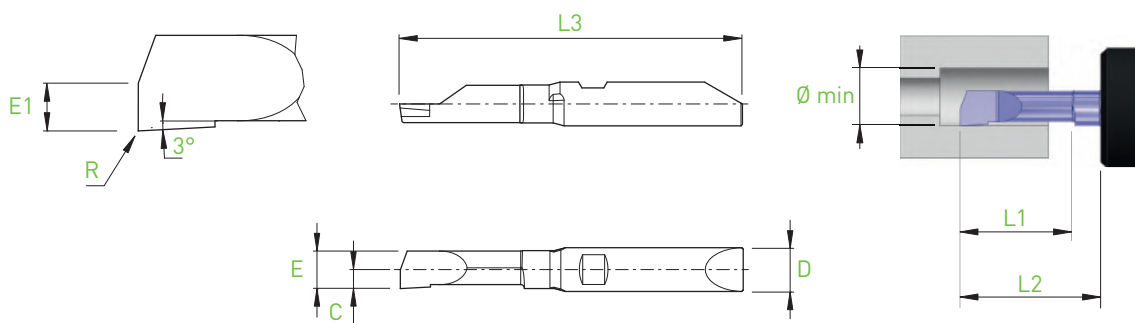

D h5	Holder	Ø min	L1	L2 BH4... BHY4...	L2 BHS4... BHK4...	E	E1	C	R	L3	Art. N°	R			L		
												ZTAF	ZTAXF	ZN	ZTAF	ZTAXF	ZN
4	BH4... BHS4... BHY4... BHK4...	0.3	0.9	10	8.5	0.27	0.13	0.15	0	32	BF4R/L-0309-BA	■	■	■	□	□	□
		0.4	1.2	10	8.5	0.36	0.18	0.20	0	32	BF4R/L-0412-BA	■	■	■	□	□	□
		0.5	1.5	10	8.5	0.45	0.22	0.25	0	32	BF4R/L-0515-BA	■	■	■	□	□	□
		0.6	1.8	10	8.5	0.54	0.27	0.30	0	32	BF4R/L-0618-BA	■	■	■	□	□	new
		0.7	2.1	10	8.5	0.63	0.31	0.35	0	32	BF4R/L-0721-BA	■	■	■	□	□	new
		0.8	2.4	10	8.5	0.72	0.36	0.40	0	32	BF4R/L-0824-BA	■	■	■	□	□	new
		0.9	2.7	10	8.5	0.81	0.40	0.45	0	32	BF4R/L-0927-BA	■	■	■	□	□	new
		1.0	3.0	10	8.5	0.90	0.45	0.60	0.02	32	BF4R/L-1030-BA-R02	■	■	■	□	□	
		1.2	3.6	10	8.5	1.08	0.54	0.60	0.02	32	BF4R/L-1236-BA-R02	■	■	■	□	□	new
		1.5	4.5	10	8.5	1.35	0.67	0.65	0.02	32	BF4R/L-1545-BA-R02	■	■	■	□	□	
		2.0	6.0	10	8.5	1.80	0.90	1.15	0.02	32	BF4R/L-2060-BA-R02	■	■	■	□	□	
		2.5	7.5	10	8.5	2.25	1.13	1.30	0.02	32	BF4R/L-2575-BA-R02	■	■	■	□	□	
		3.0	9.0	15	13.5	2.70	1.35	1.35	0.05	37	BF4R/L-3090-BA-R05	■	■	■	□	□	
		3.5	10.5	15	13.5	3.15	1.58	1.60	0.05	37	BF4R/L-35105-BA-R05	■	■	■	□	□	

■ = disponible / verfügbar / available  
□ = selon disponibilité du stock / jenach Lagerverfügbarkeit / depending the stock availability

# IN-LINE

Alésage  
Ausbohren  
Boring

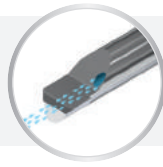

## BB4... / BB6...

## BAX

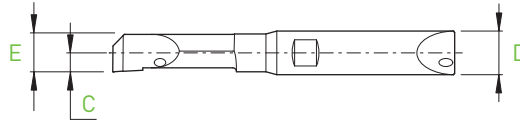
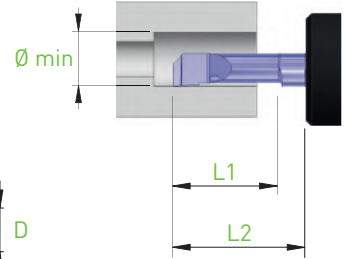
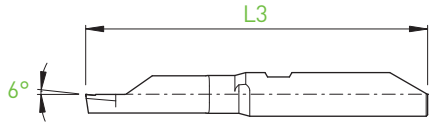
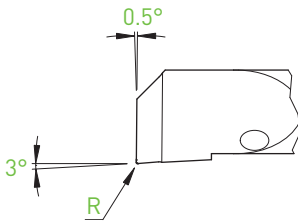

D <sub>h5</sub>	Holder	Ø min	L1	L2 BH4... BHY4...	L2 BHS4... BHK4...	E	C	R	L3	Art. N°	R			L		
											ZTAF	ZTAXF	ZN	ZTAF	ZN	
4	BH4... BHS4... BHY4... BHK4...	0.5	1.5	10	8.5	0.45	0.25	0	32	BB4R/L-0515-BAX	■	■	■	□	□	
		0.6	1.8	10	8.5	0.54	0.30	0	32	BB4R/L-0618-BAX	■	■	■	□	□	
		0.7	2.1	10	8.5	0.63	0.35	0	32	BB4R/L-0721-BAX	■	■	■	□	□	
		0.8	2.4	10	8.5	0.72	0.40	0	32	BB4R/L-0824-BAX	■	■	■	□	□	
		0.9	2.7	10	8.5	0.81	0.45	0	32	BB4R/L-0927-BAX	■	■	■	□	□	
		1.0	3.0	10	8.5	0.90	0.60	0.02	32	BB4R/L-1030-BAX-R02	■	■	■	□	□	
			5.0	10	8.5	0.90	0.60	0.02	32	BB4R/L-1050-BAX-R02	■	■	■	□	□	
		1.5	4.5	10	8.5	1.35	0.65	0.02	32	BB4R/L-1545-BAX-R02	■	■	■	□	□	
			7.5	10	8.5	1.35	0.65	0.02	32	BB4R/L-1575-BAX-R02	■	■	■	□	□	
		2.0	6.0	10	8.5	1.80	1.15	0.02	32	BB4R/L-2060-BAX-R02	■	■	■	□	□	
			10.0	15	13.5	1.80	1.15	0.02	37	BB4R/L-20100-BAX-R02	■	■	■	□	□	
		2.5	7.5	10	8.5	2.25	1.30	0.05	32	BB4R/L-2575-BAX-R05	■	■	■	□	□	
			12.5	15	13.5	2.25	1.30	0.05	37	BB4R/L-25125-BAX-R05	■	■	■	□	□	
		3.0	9.0	15	13.5	2.70	1.35	0.05	37	BB4R/L-3090-BAX-R05	■	■	■	□	□	
			15.0	20	18.5	2.70	1.35	0.05	42	BB4R/L-30150-BAX-R05	■	■	■	□	□	
		3.5	10.5	15	13.5	3.15	1.60	0.05	37	BB4R/L-35105-BAX-R05	■	■	■	□	□	
17.5	20		18.5	3.15	1.60	0.05	42	BB4R/L-35175-BAX-R05	■	■	■	□	□			

D <sub>h5</sub>	Holder	Ø min	L1	L2 BH6... BHY6...	L2 BHS6... BHK6...	E	C	R	L3	Art. N°	ZTAF	ZTAXF	ZN	ZTAF	ZN
											■	■	■	□	□
6	BH6... BHS6... BHY6... BHK6...	4.0	12.0	20	18.5	3.80	2.20	0.05	47	BB6R/L-40120-BAX-R05	■	■	■	□	□
			20.0	30	28.5	3.80	2.20	0.05	57	BB6R/L-40200-BAX-R05	■	■	■	□	□
		4.5	13.5	20	18.5	4.28	2.30	0.05	47	BB6R/L-45135-BAX-R05	■	■	■	□	□
			22.5	30	28.5	4.28	2.30	0.05	57	BB6R/L-45225-BAX-R05	■	■	■	□	□
		5.0	15.0	20	18.5	4.75	2.40	0.05	47	BB6R/L-50150-BAX-R05	■	■	■	□	□
			25.0	30	28.5	4.75	2.40	0.05	57	BB6R/L-50250-BAX-R05	■	■	■	□	□
		5.5	16.5	20	18.5	5.15	2.60	0.05	47	BB6R/L-55165-BAX-R05	■	■	■	□	□
			27.5	30	28.5	5.15	2.60	0.05	57	BB6R/L-55275-BAX-R05	■	■	■	□	□

Alésage  
Ausbohren  
Boring

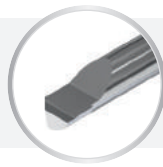

BF4... / BF6...

BAX

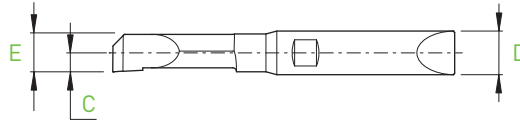
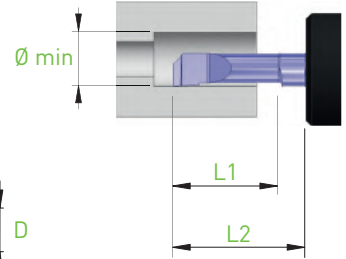
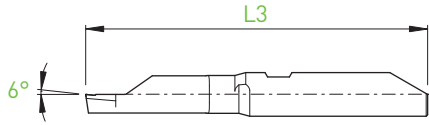
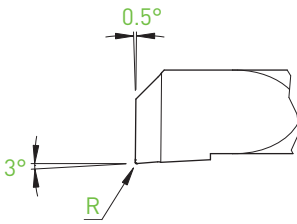

D h5	Holder	Ø min	L1	L2 BH4... BHY4...	L2 BHS4... BHK4...	E	C	R	L3	Art. N°	R			L		
											ZTAF	ZTAXF	ZN	ZTAF	ZN	
4	BH4... BHS4... BHY4... BHK4...	0.5	1.5	10	8.5	0.45	0.25	0	32	BF4R/L-0515-BAX	■	■	■	□	□	
		0.6	1.8	10	8.5	0.54	0.30	0	32	BF4R/L-0618-BAX	■	■	■	□	□	
		0.7	2.1	10	8.5	0.63	0.35	0	32	BF4R/L-0721-BAX	■	■	■	□	□	
		0.8	2.4	10	8.5	0.72	0.40	0	32	BF4R/L-0824-BAX	■	■	■	□	□	
		0.9	2.7	10	8.5	0.81	0.45	0	32	BF4R/L-0927-BAX	■	■	■	□	□	
		1.0	3.0	10	8.5	0.90	0.60	0.02	32	BF4R/L-1030-BAX-R02	■	■	■	□	□	
			5.0	10	8.5	0.90	0.60	0.02	32	BF4R/L-1050-BAX-R02	■	■	■	□	□	
		1.5	4.5	10	8.5	1.35	0.65	0.02	32	BF4R/L-1545-BAX-R02	■	■	■	□	□	
			7.5	10	8.5	1.35	0.65	0.02	32	BF4R/L-1575-BAX-R02	■	■	■	□	□	
		2.0	6.0	10	8.5	1.80	1.15	0.02	32	BF4R/L-2060-BAX-R02	■	■	■	□	□	
			10.0	15	13.5	1.80	1.15	0.02	37	BF4R/L-20100-BAX-R02	■	■	■	□	□	
		2.5	7.5	10	8.5	2.25	1.30	0.05	32	BF4R/L-2575-BAX-R05	■	■	■	□	□	
			12.5	15	13.5	2.25	1.30	0.05	37	BF4R/L-25125-BAX-R05	■	■	■	□	□	
		3.0	9.0	15	13.5	2.70	1.35	0.05	37	BF4R/L-3090-BAX-R05	■	■	■	□	□	
			15.0	20	18.5	2.70	1.35	0.05	42	BF4R/L-30150-BAX-R05	■	■	■	□	□	
		3.5	10.5	15	13.5	3.15	1.60	0.05	37	BF4R/L-35105-BAX-R05	■	■	■	□	□	
17.5	20		18.5	3.15	1.60	0.05	42	BF4R/L-35175-BAX-R05	■	■	■	□	□			

D h5	Holder	Ø min	L1	L2 BH6... BHY6...	L2 BHS6... BHK6...	E	C	R	L3	Art. N°	ZTAF	ZTAXF	ZN	ZTAF	ZN
											■	■	■	■	■
6	BH6... BHS6... BHY6... BHK6...	4.0	12.0	20	18.5	3.80	2.20	0.05	47	BF6R/L-40120-BAX-R05	■	■	■	□	□
			20.0	30	28.5	3.80	2.20	0.05	57	BF6R/L-40200-BAX-R05	■	■	■	□	□
		4.5	13.5	20	18.5	4.28	2.30	0.05	47	BF6R/L-45135-BAX-R05	■	■	■	□	□
			22.5	30	28.5	4.28	2.30	0.05	57	BF6R/L-45225-BAX-R05	■	■	■	□	□
		5.0	15.0	20	18.5	4.75	2.40	0.05	47	BF6R/L-50150-BAX-R05	■	■	■	□	□
			25.0	30	28.5	4.75	2.40	0.05	57	BF6R/L-50250-BAX-R05	■	■	■	□	□
		5.5	16.5	20	18.5	5.15	2.60	0.05	47	BF6R/L-55165-BAX-R05	■	■	■	□	□
			27.5	30	28.5	5.15	2.60	0.05	57	BF6R/L-55275-BAX-R05	■	■	■	□	□

■ = disponible / verfügbar / available  
□ = selon disponibilité du stock / jenach Lagerverfügbarkeit / depending the stock availability

# IN-LINE

- Alésage-copiage
- Ausbohren-kopieren
- Boring chambering

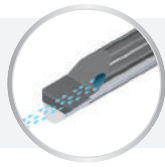

BB4... / BB6...

BCX

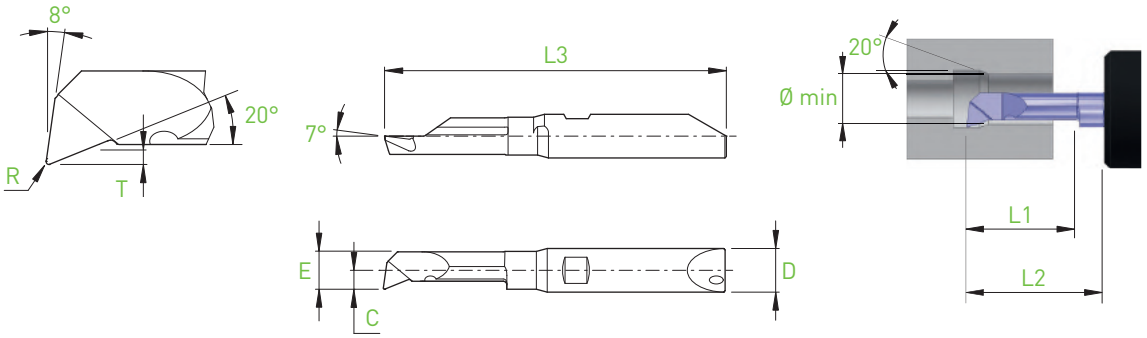

D h5	Holder	Ø min	L1	L2 BH4... BHY4...	L2 BHS4... BHK4...	T	E	C	R	L3	Art. N°	R		L				
												ZTAF	ZTAXF	ZN	ZTAF	ZN		
4	BH4... BHS4... BHY4... BHK4...	1.0	3.0	10	8.5	0.15	0.90	0.70	0.05	32	BB4R/L-1030-BCX-R05	■	■	■	□	□		
			5.0	10	8.5	0.15	0.90	0.70	0.05	32	BB4R/L-1050-BCX-R05	■	■	■	□	□		
		1.5	4.5	10	8.5	0.23	1.35	0.75	0.05	32	BB4R/L-1545-BCX-R05	■	■	■	□	□		
			7.5	10	8.5	0.23	1.35	0.75	0.05	32	BB4R/L-1575-BCX-R05	■	■	■	□	□		
		2.0	6.0	10	8.5	0.30	1.80	1.15	0.05	32	BB4R/L-2060-BCX-R05	■	■	■	□	□		
			10.0	15	13.5	0.30	1.80	1.15	0.05	37	BB4R/L-20100-BCX-R05	■	■	■	□	□		
		2.5	7.5	10	8.5	0.38	2.25	1.30	0.10	32	BB4R/L-2575-BCX-R10	■	■	■	□	□		
			12.5	15	13.5	0.38	2.25	1.30	0.10	37	BB4R/L-25125-BCX-R10	■	■	■	□	□		
		3.0	9.0	15	13.5	0.45	2.70	1.35	0.10	37	BB4R/L-3090-BCX-R10	■	■	■	□	□		
			15.0	20	18.5	0.45	2.70	1.35	0.10	42	BB4R/L-30150-BCX-R10	■	■	■	□	□		
		3.5	10.5	15	13.5	0.53	3.15	1.60	0.10	37	BB4R/L-35105-BCX-R10	■	■	■	□	□		
			17.5	20	18.5	0.53	3.15	1.60	0.10	42	BB4R/L-35175-BCX-R10	■	■	■	□	□		
		D h5	Holder	Ø min	L1	L2 BH6... BHY6...	L2 BHS6... BHK6...	T	E	C	R	L3	Art. N°	ZTAF	ZTAXF	ZN	ZTAF	ZN
		6	BH6... BHS6... BHY6... BHK6...	4.0	12.0	20	18.5	0.60	3.80	2.20	0.15	47	BB6R/L-40120-BCX-R15	■	■	■	□	□
20.0	30				28.5	0.60	3.80	2.20	0.15	57	BB6R/L-40200-BCX-R15	■	■	■	□	□		
4.5	13.5			20	18.5	0.68	4.28	2.30	0.15	47	BB6R/L-45135-BCX-R15	■	■	■	□	□		
	22.5			30	28.5	0.68	4.28	2.30	0.15	57	BB6R/L-45225-BCX-R15	■	■	■	□	□		
5.0	15.0			20	18.5	0.75	4.75	2.40	0.15	47	BB6R/L-50150-BCX-R15	■	■	■	□	□		
	25.0			30	28.5	0.75	4.75	2.40	0.15	57	BB6R/L-50250-BCX-R15	■	■	■	□	□		
5.5	16.5			20	18.5	0.83	5.15	2.60	0.15	47	BB6R/L-55165-BCX-R15	■	■	■	□	□		
	27.5			30	28.5	0.83	5.15	2.60	0.15	57	BB6R/L-55275-BCX-R15	■	■	■	□	□		

Alésage-copiage  
 Ausbohren-kopieren  
 Boring chambering

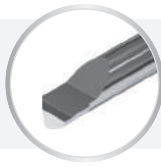

BF4... / BF6...

BCX

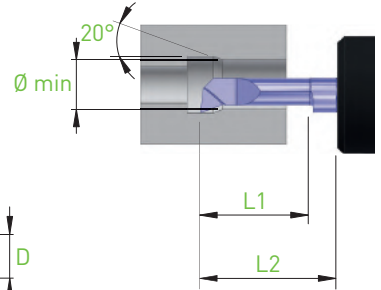
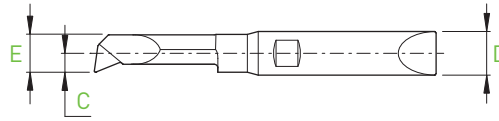
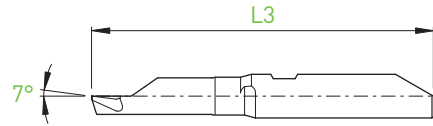
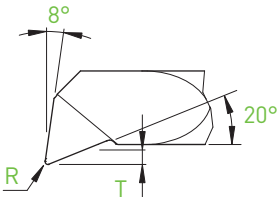

D h5	Holder	Ø min	L1	L2 BH4... BHY4...	L2 BHS4... BHK4...	T	E	C	R	L3	Art. N°	R		L		
												ZTAF	ZTAXF	ZN	ZTAF	ZN
4	BH4... BHS4... BHY4... BHK4...	1.0	3.0	10	8.5	0.15	0.90	0.70	0.05	32	BF4R/L-1030-BCX-R05	■	■	■	□	□
			5.0	10	8.5	0.15	0.90	0.70	0.05	32	BF4R/L-1050-BCX-R05	■	■	■	□	□
		1.5	4.5	10	8.5	0.23	1.35	0.75	0.05	32	BF4R/L-1545-BCX-R05	■	■	■	□	□
			7.5	10	8.5	0.23	1.35	0.75	0.05	32	BF4R/L-1575-BCX-R05	■	■	■	□	□
		2.0	6.0	10	8.5	0.30	1.80	1.15	0.05	32	BF4R/L-2060-BCX-R05	■	■	■	□	□
			10.0	15	13.5	0.30	1.80	1.15	0.05	37	BF4R/L-20100-BCX-R05	■	■	■	□	□
		2.5	7.5	10	8.5	0.38	2.25	1.30	0.10	32	BF4R/L-2575-BCX-R10	■	■	■	□	□
			12.5	15	13.5	0.38	2.25	1.30	0.10	37	BF4R/L-25125-BCX-R10	■	■	■	□	□
		3.0	9.0	15	13.5	0.45	2.70	1.35	0.10	37	BF4R/L-3090-BCX-R10	■	■	■	□	□
			15.0	20	18.5	0.45	2.70	1.35	0.10	42	BF4R/L-30150-BCX-R10	■	■	■	□	□
		3.5	10.5	15	13.5	0.53	3.15	1.60	0.10	37	BF4R/L-35105-BCX-R10	■	■	■	□	□
			17.5	20	18.5	0.53	3.15	1.60	0.10	42	BF4R/L-35175-BCX-R10	■	■	■	□	□
D h5	Holder	Ø min	L1	L2 BH6... BHY6...	L2 BHS6... BHK6...	T	E	C	R	L3	Art. N°	ZTAF	ZTAXF	ZN	ZTAF	ZN
6	BH6... BHS6... BHY6... BHK6...	4.0	12.0	20	18.5	0.60	3.80	2.20	0.15	47	BF6R/L-40120-BCX-R15	■	■	■	□	□
			20.0	30	28.5	0.60	3.80	2.20	0.15	57	BF6R/L-40200-BCX-R15	■	■	■	□	□
		4.5	13.5	20	18.5	0.68	4.28	2.30	0.15	47	BF6R/L-45135-BCX-R15	■	■	■	□	□
			22.5	30	28.5	0.68	4.28	2.30	0.15	57	BF6R/L-45225-BCX-R15	■	■	■	□	□
		5.0	15.0	20	18.5	0.75	4.75	2.40	0.15	47	BF6R/L-50150-BCX-R15	■	■	■	□	□
			25.0	30	28.5	0.75	4.75	2.40	0.15	57	BF6R/L-50250-BCX-R15	■	■	■	□	□
		5.5	16.5	20	18.5	0.83	5.15	2.60	0.15	47	BF6R/L-55165-BCX-R15	■	■	■	□	□
			27.5	30	28.5	0.83	5.15	2.60	0.15	57	BF6R/L-55275-BCX-R15	■	■	■	□	□

■ = disponible / verfügbar / available  
 □ = selon disponibilité du stock / jenach Lagerverfügbarkeit / depending the stock availability

Copiage  
Kopieren  
Chamfering

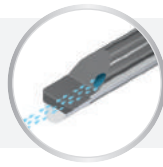

## BB4... / BB6...

## C45

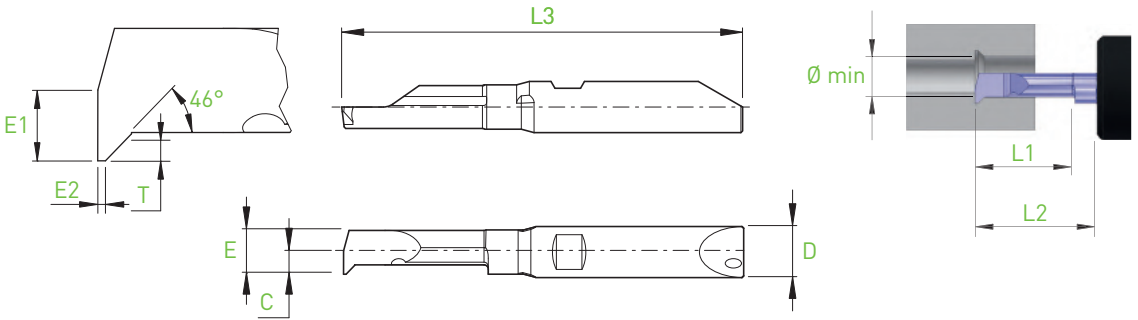

D h5	Holder	Ø min	L1	L2 BH4... BHY4...	L2 BHS4... BHK4...	T	E	E1	C	E2	L3	Art. N°	R		L	
													ZTAF	ZTAXF	ZN	ZTAF
4	BH4... BHS4... BHY4... BHK4...	0.3	0.6	10	8.5	0.05	0.27	0.13	0.15	0.03	32	BB4R/L-0306-C45-E03	<input type="checkbox"/>	<input type="checkbox"/>	<input type="checkbox"/>	<input type="checkbox"/>
		0.4	0.8	10	8.5	0.07	0.36	0.18	0.20	0.03	32	BB4R/L-0408-C45-E03	<input type="checkbox"/>	<input type="checkbox"/>	<input type="checkbox"/>	<input type="checkbox"/>
		0.5	1.0	10	8.5	0.08	0.45	0.22	0.25	0.03	32	BB4R/L-0510-C45-E03	<input type="checkbox"/>	<input type="checkbox"/>	<input type="checkbox"/>	<input type="checkbox"/>
		0.6	1.2	10	8.5	0.10	0.54	0.27	0.30	0.03	32	BB4R/L-0612-C45-E03	<input type="checkbox"/>	<input type="checkbox"/>	<input type="checkbox"/>	<input type="checkbox"/>
		0.7	1.2	10	8.5	0.12	0.63	0.32	0.35	0.03	32	BB4R/L-0714-C45-E03	<input type="checkbox"/>	<input type="checkbox"/>	<input type="checkbox"/>	<input type="checkbox"/>
		0.8	1.6	10	8.5	0.14	0.72	0.36	0.40	0.05	32	BB4R/L-0816-C45-E05	<input type="checkbox"/>	<input type="checkbox"/>	<input type="checkbox"/>	<input type="checkbox"/>
		0.9	1.8	10	8.5	0.15	0.81	0.41	0.45	0.05	32	BB4R/L-0918-C45-E05	<input type="checkbox"/>	<input type="checkbox"/>	<input type="checkbox"/>	<input type="checkbox"/>
		1.0	3.0	10	8.5	0.17	0.90	0.45	0.70	0.10	32	BB4R/L-1030-C45-E10	<input type="checkbox"/>	<input type="checkbox"/>	<input type="checkbox"/>	<input type="checkbox"/>
		1.2	3.6	10	8.5	0.20	1.08	0.54	0.70	0.10	32	BB4R/L-1236-C45-E10	<input type="checkbox"/>	<input type="checkbox"/>	<input type="checkbox"/>	<input type="checkbox"/>
		1.5	4.5	10	8.5	0.25	1.35	0.67	0.75	0.10	32	BB4R/L-1545-C45-E10	<input type="checkbox"/>	<input type="checkbox"/>	<input type="checkbox"/>	<input type="checkbox"/>
		2.0	6.0	10	8.5	0.34	1.80	0.90	1.15	0.20	32	BB4R/L-2060-C45-E20	<input type="checkbox"/>	<input type="checkbox"/>	<input type="checkbox"/>	<input type="checkbox"/>
		2.5	7.5	10	8.5	0.43	2.25	1.13	1.30	0.20	32	BB4R/L-2575-C45-E20	<input type="checkbox"/>	<input type="checkbox"/>	<input type="checkbox"/>	<input type="checkbox"/>
3.0	9.0	15	13.5	0.51	2.70	1.35	1.35	0.30	37	BB4R/L-3090-C45-E30	<input type="checkbox"/>	<input type="checkbox"/>	<input type="checkbox"/>	<input type="checkbox"/>		
3.5	10.5	15	13.5	0.60	3.15	1.58	1.60	0.30	37	BB4R/L-35105-C45-E30	<input type="checkbox"/>	<input type="checkbox"/>	<input type="checkbox"/>	<input type="checkbox"/>		
6	BH6... BHS6... BHY6... BHK6...	4.0	12.0	20	18.5	0.68	3.80	1.90	2.30	0.40	47	BB6R/L-40120-C45-E40	<input type="checkbox"/>	<input type="checkbox"/>	<input type="checkbox"/>	<input type="checkbox"/>
		5.0	15.0	20	18.5	0.85	4.75	2.37	2.50	0.50	47	BB6R/L-50150-C45-E50	<input type="checkbox"/>	<input type="checkbox"/>	<input type="checkbox"/>	<input type="checkbox"/>

new



- Copiage
- Kopieren
- Chambering



BF4... / BF6...

C45

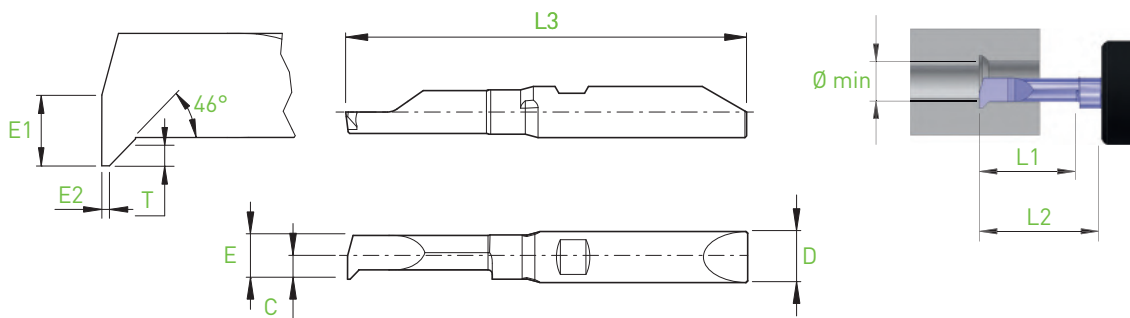

D h5	Holder	Ø min	L1	L2 BH4... BHY4...	L2 BHS4... BHK4...	T	E	E1	C	E2	L3	Art. N°	R		L		
													ZTAF	ZTAXF	ZN	ZTAF	ZN
4	BH4... BHS4... BHY4... BHK4...	0.3	0.6	10	8.5	0.05	0.27	0.13	0.15	0.03	32	BF4R/L-0306-C45-E03	■	■	■	□	□
		0.4	0.8	10	8.5	0.07	0.36	0.18	0.20	0.03	32	BF4R/L-0408-C45-E03	■	■	■	□	□
		0.5	1.0	10	8.5	0.08	0.45	0.22	0.25	0.03	32	BF4R/L-0510-C45-E03	■	■	■	□	□
		0.6	1.2	10	8.5	0.10	0.54	0.27	0.30	0.03	32	BF4R/L-0612-C45-E03	■	■	■	□	□
		0.7	1.2	10	8.5	0.12	0.63	0.32	0.35	0.03	32	BF4R/L-0714-C45-E03	■	■	■	□	□
		0.8	1.6	10	8.5	0.14	0.72	0.36	0.40	0.05	32	BF4R/L-0816-C45-E05	■	■	■	□	□
		0.9	1.8	10	8.5	0.15	0.81	0.41	0.45	0.05	32	BF4R/L-0918-C45-E05	■	■	■	□	□
		1.0	3.0	10	8.5	0.17	0.90	0.45	0.70	0.10	32	BF4R/L-1030-C45-E10	■	■	■	□	□
		1.2	3.6	10	8.5	0.20	1.08	0.54	0.70	0.10	32	BF4R/L-1236-C45-E10	■	■	■	□	□
		1.5	4.5	10	8.5	0.25	1.35	0.67	0.75	0.10	32	BF4R/L-1545-C45-E10	■	■	■	□	□
		2.0	6.0	10	8.5	0.34	1.80	0.90	1.15	0.20	32	BF4R/L-2060-C45-E20	■	■	■	□	□
		2.5	7.5	10	8.5	0.43	2.25	1.13	1.30	0.20	32	BF4R/L-2575-C45-E20	■	■	■	□	□
3.0	9.0	15	13.5	0.51	2.70	1.35	1.35	0.30	37	BF4R/L-3090-C45-E30	■	■	■	□	□		
3.5	10.5	15	13.5	0.60	3.15	1.58	1.60	0.30	37	BF4R/L-35105-C45-E30	■	■	■	□	□		
6	BH6... BHS6... BHY6... BHK6...	4.0	12.0	20	18.5	0.68	3.80	1.90	2.30	0.40	47	BF6R/L-40120-C45-E40	■	■	■	□	□
		5.0	15.0	20	18.5	0.85	4.75	2.37	2.50	0.50	47	BF6R/L-50150-C45-E50	■	■	■	□	□

■ = disponible / verfügbar / available  
 □ = selon disponibilité du stock / jenach Lagerverfügbarkeit / depending the stock availability

Copiage  
Kopieren  
Chamfering

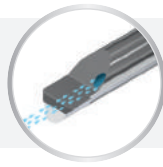

## BB4... / BB6...

## C45X

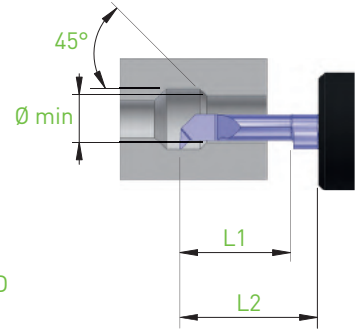
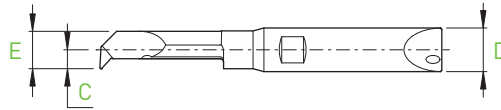
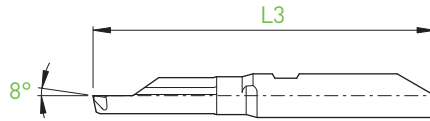
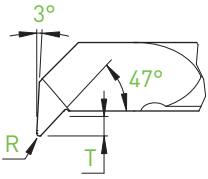

D h5	Holder	Ø min	L1	L2 BH4... BHY4...	L2 BHS4... BHK4...	T	E	C	R	L3	Art. N°	R		L	
												ZTAF	ZTAXF	ZN	ZTAF
4	BH4... BHS4... BHY4... BHK4...	2.5	7.5	10	8.5	0.50	2.25	1.35	0.10	32	<b>BB4R/L-2575-C45X-R10</b>	<input checked="" type="checkbox"/>	<input checked="" type="checkbox"/>	<input type="checkbox"/>	<input type="checkbox"/>
			12.5	15	13.5	0.50	2.25	1.35	0.10	37	<b>BB4R/L-25125-C45X-R10</b>	<input checked="" type="checkbox"/>	<input checked="" type="checkbox"/>	<input type="checkbox"/>	<input type="checkbox"/>
		3.0	9.0	15	13.5	0.60	2.70	1.45	0.10	37	<b>BB4R/L-3090-C45X-R10</b>	<input checked="" type="checkbox"/>	<input checked="" type="checkbox"/>	<input type="checkbox"/>	<input type="checkbox"/>
			15.0	20	18.5	0.60	2.70	1.45	0.10	42	<b>BB4R/L-30150-C45X-R10</b>	<input checked="" type="checkbox"/>	<input checked="" type="checkbox"/>	<input type="checkbox"/>	<input type="checkbox"/>
		3.5	10.5	15	13.5	0.70	3.15	1.60	0.10	37	<b>BB4R/L-35105-C45X-R10</b>	<input checked="" type="checkbox"/>	<input checked="" type="checkbox"/>	<input type="checkbox"/>	<input type="checkbox"/>
			17.5	20	18.5	0.70	3.15	1.60	0.10	42	<b>BB4R/L-35175-C45X-R10</b>	<input checked="" type="checkbox"/>	<input checked="" type="checkbox"/>	<input type="checkbox"/>	<input type="checkbox"/>
6	BH6... BHS6... BHY6... BHK6...	4.0	12.0	20	18.5	0.80	3.80	2.30	0.15	47	<b>BB6R/L-40120-C45X-R15</b>	<input checked="" type="checkbox"/>	<input checked="" type="checkbox"/>	<input type="checkbox"/>	<input type="checkbox"/>
			20.0	30	28.5	0.80	3.80	2.30	0.15	57	<b>BB6R/L-40200-C45X-R15</b>	<input checked="" type="checkbox"/>	<input checked="" type="checkbox"/>	<input type="checkbox"/>	<input type="checkbox"/>
		4.5	13.5	20	18.5	0.90	4.28	2.40	0.15	47	<b>BB6R/L-45135-C45X-R15</b>	<input checked="" type="checkbox"/>	<input checked="" type="checkbox"/>	<input type="checkbox"/>	<input type="checkbox"/>
			22.5	30	28.5	0.90	4.28	2.40	0.15	57	<b>BB6R/L-45225-C45X-R15</b>	<input checked="" type="checkbox"/>	<input checked="" type="checkbox"/>	<input type="checkbox"/>	<input type="checkbox"/>
		5.0	15.0	20	18.5	1.00	4.75	2.50	0.15	47	<b>BB6R/L-50150-C45X-R15</b>	<input checked="" type="checkbox"/>	<input checked="" type="checkbox"/>	<input type="checkbox"/>	<input type="checkbox"/>
			25.0	30	28.5	1.00	4.75	2.50	0.15	57	<b>BB6R/L-50250-C45X-R15</b>	<input checked="" type="checkbox"/>	<input checked="" type="checkbox"/>	<input type="checkbox"/>	<input type="checkbox"/>
		5.5	16.5	20	18.5	1.10	5.15	2.60	0.15	47	<b>BB6R/L-55165-C45X-R15</b>	<input checked="" type="checkbox"/>	<input checked="" type="checkbox"/>	<input type="checkbox"/>	<input type="checkbox"/>
			27.5	30	28.5	1.10	5.15	2.60	0.15	57	<b>BB6R/L-55275-C45X-R15</b>	<input checked="" type="checkbox"/>	<input checked="" type="checkbox"/>	<input type="checkbox"/>	<input type="checkbox"/>

Copiage  
Kopieren  
Chambering

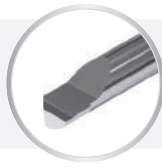

BF4... / BF6...

C45X

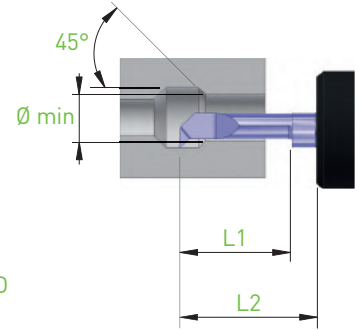
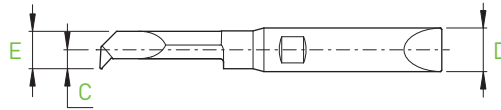
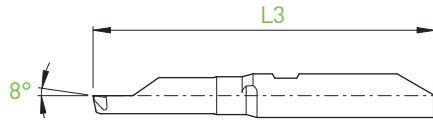
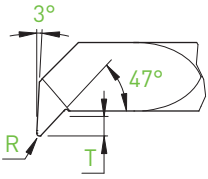

D <sub>h5</sub>	Holder	Ø min	L1	L2 BH4... BHY4...	L2 BHS4... BHK4...	T	E	C	R	L3	Art. N°	R		L		
												ZTAF	ZTAXF	ZN	ZTAF	ZN
4	BH4... BHS4... BHY4... BHK4...	2.5	7.5	10	8.5	0.50	2.25	1.35	0.10	32	<b>BF4R/L-2575-C45X-R10</b>	■	■	■	□	□
			12.5	15	13.5	0.50	2.25	1.35	0.10	37	<b>BF4R/L-25125-C45X-R10</b>	■	■	■	□	□
		3.0	9.0	15	13.5	0.60	2.70	1.45	0.10	37	<b>BF4R/L-3090-C45X-R10</b>	■	■	■	□	□
			15.0	20	18.5	0.60	2.70	1.45	0.10	42	<b>BF4R/L-30150-C45X-R10</b>	■	■	■	□	□
		3.5	10.5	15	13.5	0.70	3.15	1.60	0.10	37	<b>BF4R/L-35105-C45X-R10</b>	■	■	■	□	□
			17.5	20	18.5	0.70	3.15	1.60	0.10	42	<b>BF4R/L-35175-C45X-R10</b>	■	■	■	□	□
D <sub>h5</sub>	Holder	Ø min	L1	L2 BH6... BHY6...	L2 BHS6... BHK6...	T	E	C	R	L3	Art. N°	ZTAF	ZTAXF	ZN	ZTAF	ZN
6	BH6... BHS6... BHY6... BHK6...	4.0	12.0	20	18.5	0.80	3.80	2.30	0.15	47	<b>BF6R/L-40120-C45X-R15</b>	■	■	■	□	□
			20.0	30	28.5	0.80	3.80	2.30	0.15	57	<b>BF6R/L-40200-C45X-R15</b>	■	■	■	□	□
		4.5	13.5	20	18.5	0.90	4.28	2.40	0.15	47	<b>BF6R/L-45135-C45X-R15</b>	■	■	■	□	□
			22.5	30	28.5	0.90	4.28	2.40	0.15	57	<b>BF6R/L-45225-C45X-R15</b>	■	■	■	□	□
		5.0	15.0	20	18.5	1.00	4.75	2.50	0.15	47	<b>BF6R/L-50150-C45X-R15</b>	■	■	■	□	□
			25.0	30	28.5	1.00	4.75	2.50	0.15	57	<b>BF6R/L-50250-C45X-R15</b>	■	■	■	□	□
		5.5	16.5	20	18.5	1.10	5.15	2.60	0.15	47	<b>BF6R/L-55165-C45X-R15</b>	■	■	■	□	□
			27.5	30	28.5	1.10	5.15	2.60	0.15	57	<b>BF6R/L-55275-C45X-R15</b>	■	■	■	□	□

■ = disponible / verfügbar / available  
□ = selon disponibilité du stock / jenach Lagerverfügbarkeit / depending the stock availability

# IN-LINE

Gorge  
Einstecken  
Grooving

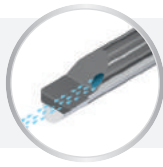

## BB4... / BB6...

## GX

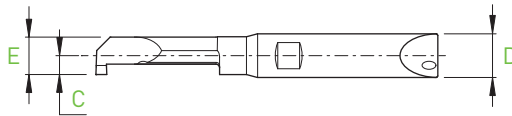
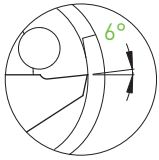
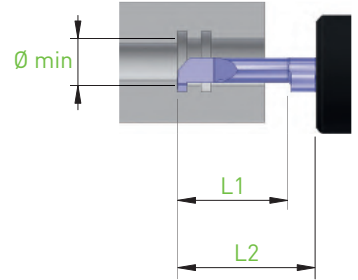
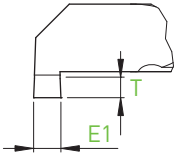

D <sub>h5</sub>	Holder	Ø min	L1	L2 BH4... BHY4...	L2 BHS4... BHK4...	E1	T	E	C	L3	Art. N°	R			L			
												ZTAF	ZTAXF	ZN	ZTAF	ZTAXF	ZN	
4	BH4... BHS4... BHY4... BHK4...	3.0	9.0	15	13.5	0.50	0.60	2.70	1.45	37	BB4R/L-3090-G050X	■	■	■	□	□	□	
			15.0	20	18.5	0.50	0.60	2.70	1.45	42	BB4R/L-30150-G050X	■	■	■	□	□	□	
		3.5	10.5	15	13.5	0.75	0.70	3.15	1.60	37	BB4R/L-35105-G075X	■	■	■	□	□	□	
			17.5	20	18.5	0.75	0.70	3.15	1.60	42	BB4R/L-35175-G075X	■	■	■	□	□	□	
D <sub>h5</sub>	Holder	Ø min	L1	L2 BH6... BHY6...	L2 BHS6... BHK6...	E1	T	E	C	L3	Art. N°	ZTAF	ZTAXF	ZN	ZTAF	ZN		
6	BH6... BHS6... BHY6... BHK6...	4.0	12.0	20	18.5	1.00	0.80	3.80	2.20	47	BB6R/L-40120-G100X	■	■	■	□	□	□	
			20.0	30	28.5	1.00	0.80	3.80	2.20	57	BB6R/L-40200-G100X	■	■	■	□	□	□	
			4.5	13.5	20	18.5	1.00 1.50	0.90	4.28	2.40	47	BB6R/L-45135-G100X BB6R/L-45135-G150X	■	■	■	□	□	□
				22.5	30	28.5	1.00 1.50	0.90	4.28	2.40	57	BB6R/L-45225-G100X BB6R/L-45225-G150X	■	■	■	□	□	□
		5.0	15.0	20	18.5	1.00 1.50	1.00	4.75	2.50	47	BB6R/L-50150-G100X BB6R/L-50150-G150X	■	■	■	□	□	□	
				25.0	30	28.5	1.00 1.50	1.00	4.75	2.50	57	BB6R/L-50250-G100X BB6R/L-50250-G150X	■	■	■	□	□	□
			5.5	16.5	20	18.5	1.00 1.50 2.00	1.10	5.15	2.60	47	BB6R/L-55165-G100X BB6R/L-55165-G150X BB6R/L-55165-G200X	■	■	■	□	□	□
					27.5	30	28.5	1.00 1.50 2.00	1.10	5.15	2.60	57	BB6R/L-55275-G100X BB6R/L-55275-G150X BB6R/L-55275-G200X	■	■	■	□	□

Gorge  
Einstecken  
Grooving

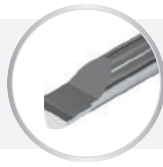

BF4... / BF6...

GX

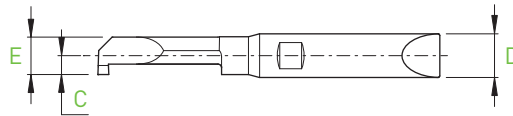
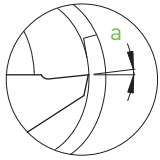
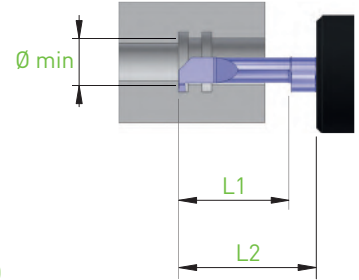
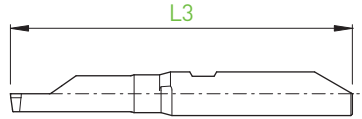
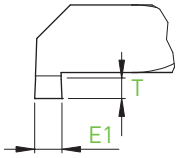

D h5	Holder	Ø min	L1	L2		E1	T	E	a	C	L3	Art. N°	R		L	
				BH4... BHY4...	BHS4... BHK4...								ZTAF	ZTAXF	ZN	ZTAF
4	BH4... BHS4... BHY4... BHK4...	0.5	1.0	10	8.5	0.15	0.10	0.45	3°	0.25	32	BF4R/L-0510-G015X	<input type="checkbox"/>	<input type="checkbox"/>	<input type="checkbox"/>	<input type="checkbox"/>
		0.7	1.4	10	8.5	0.20	0.14	0.63		0.35	32	BF4R/L-0714-G020X	<input type="checkbox"/>	<input type="checkbox"/>	<input type="checkbox"/>	<input type="checkbox"/>
		1.0	2.0	10	8.5	0.30	0.20	0.90		0.60	32	BF4R/L-1020-G030X	<input type="checkbox"/>	<input type="checkbox"/>	<input type="checkbox"/>	<input type="checkbox"/>
		1.5	3.0	10	8.5	0.40	0.30	1.35	6°	0.80	32	BF4R/L-1530-G040X	<input type="checkbox"/>	<input type="checkbox"/>	<input type="checkbox"/>	<input type="checkbox"/>
		2.0	6.0	10	8.5	0.40	0.40	1.80		1.15	32	BF4R/L-2060-G040X	<input type="checkbox"/>	<input type="checkbox"/>	<input type="checkbox"/>	<input type="checkbox"/>
		2.5	7.5	10	8.5	0.50	0.50	2.25		1.15	32	BF4R/L-2575-G050X	<input type="checkbox"/>	<input type="checkbox"/>	<input type="checkbox"/>	<input type="checkbox"/>
		3.0	9.0	15	13.5	0.50	0.60	2.70		1.45	37	BF4R/L-3090-G050X	<input type="checkbox"/>	<input type="checkbox"/>	<input type="checkbox"/>	<input type="checkbox"/>
			15.0	20	18.5	0.50	0.60	2.70		1.45	42	BF4R/L-30150-G050X	<input type="checkbox"/>	<input type="checkbox"/>	<input type="checkbox"/>	<input type="checkbox"/>
		3.5	10.5	15	13.5	0.75	0.70	3.15		1.60	37	BF4R/L-35105-G075X	<input type="checkbox"/>	<input type="checkbox"/>	<input type="checkbox"/>	<input type="checkbox"/>
			17.5	20	18.5	0.75	0.70	3.15		1.60	42	BF4R/L-35175-G075X	<input type="checkbox"/>	<input type="checkbox"/>	<input type="checkbox"/>	<input type="checkbox"/>
6	BH6... BHS6... BHY6... BHK6...	4.0	12.0	20	18.5	1.00	0.80	3.80	6°	2.20	47	BF6R/L-40120-G100X	<input type="checkbox"/>	<input type="checkbox"/>	<input type="checkbox"/>	<input type="checkbox"/>
			20.0	30	28.5	1.00	0.80	3.80		2.20	57	BF6R/L-40200-G100X	<input type="checkbox"/>	<input type="checkbox"/>	<input type="checkbox"/>	<input type="checkbox"/>
		4.5	13.5	20	18.5	1.00	0.90	4.28		2.40	47	BF6R/L-45135-G100X	<input type="checkbox"/>	<input type="checkbox"/>	<input type="checkbox"/>	<input type="checkbox"/>
			22.5	30	28.5	1.50	0.90	4.28			57	BF6R/L-45225-G100X	<input type="checkbox"/>	<input type="checkbox"/>	<input type="checkbox"/>	<input type="checkbox"/>
		5.0	15.0	20	18.5	1.00	1.00	4.75		2.50	47	BF6R/L-50150-G100X	<input type="checkbox"/>	<input type="checkbox"/>	<input type="checkbox"/>	<input type="checkbox"/>
				25.0	30	28.5	1.50	1.00			4.75	57	BF6R/L-50150-G150X	<input type="checkbox"/>	<input type="checkbox"/>	<input type="checkbox"/>
			25.0	30	28.5	1.50	1.00	4.75	57		BF6R/L-50250-G100X	<input type="checkbox"/>	<input type="checkbox"/>	<input type="checkbox"/>	<input type="checkbox"/>	
		5.5	16.5	20	18.5	1.50	1.10	5.15	2.60	47	BF6R/L-55165-G100X	<input type="checkbox"/>	<input type="checkbox"/>	<input type="checkbox"/>	<input type="checkbox"/>	
					2.00	5.15	47	BF6R/L-55165-G150X			<input type="checkbox"/>	<input type="checkbox"/>	<input type="checkbox"/>	<input type="checkbox"/>		
				2.00	5.15	47	BF6R/L-55165-G200X	<input type="checkbox"/>		<input type="checkbox"/>	<input type="checkbox"/>	<input type="checkbox"/>				
				1.00	5.15	47	BF6R/L-55275-G100X	<input type="checkbox"/>		<input type="checkbox"/>	<input type="checkbox"/>	<input type="checkbox"/>				
				1.50	5.15	57	BF6R/L-55275-G150X	<input type="checkbox"/>		<input type="checkbox"/>	<input type="checkbox"/>	<input type="checkbox"/>				
		2.00	5.15	57	BF6R/L-55275-G200X	<input type="checkbox"/>	<input type="checkbox"/>	<input type="checkbox"/>	<input type="checkbox"/>							

■ = disponible / verfügbar / available  
□ = selon disponibilité du stock / jenach Lagerverfügbarkeit / depending the stock availability

# IN-LINE

Fonçage-tournage  
Einstecken und drehen  
Grooving and turning

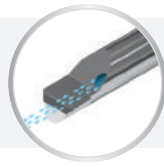

## BB4... / BB6...

## GTX

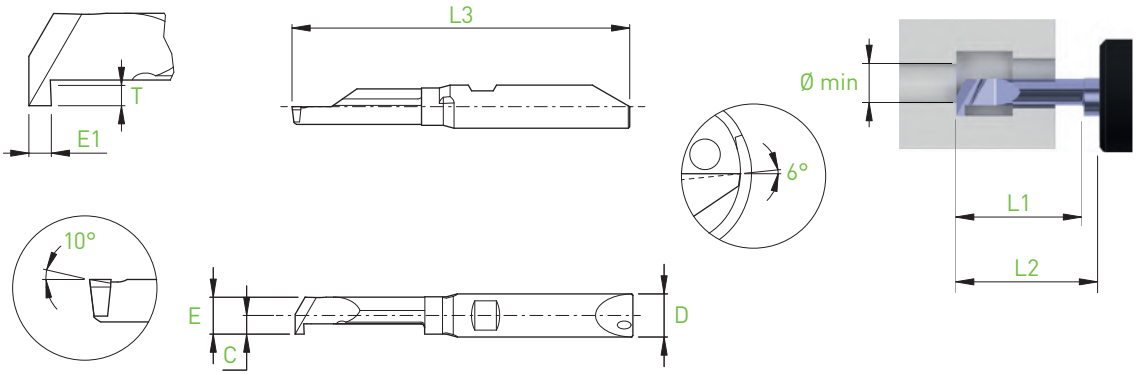

D h5	Holder	Ø min	L1	L2 BH4... BHY4...	L2 BHS4... BHK4...	E1	T	E	C	L3	Art. N°	R		L		
												ZTAF	ZTAXF	ZN	ZTAF	ZN
4	BH4... BHS4... BHY4... BHK4...	3.0	9.0	15	13.5	1.00	0.60	2.7	1.45	37	BB4R/L-3090-GT100X	■	■	■	□	□
			15.0	20	18.5	1.00	0.60	2.7	1.45	42	BB4R/L-30150-GT100X	■	■	■	□	□
	3.5	10.5	15	13.5	1.00	0.70	3.15	1.6	37	BB4R/L-35105-GT100X	■	■	■	□	□	
		17.5	20	18.5	1.00	0.70	3.15	1.6	42	BB4R/L-35175-GT100X	■	■	■	□	□	
D h5	Holder	Ø min	L1	L2 BH6... BHY6...	L2 BHS6... BHK6...	E1	T	E	C	L3	Art. N°	ZTAF	ZTAXF	ZN	ZTAF	ZN
6	BH6... BHS6... BHY6... BHK6...	4.0	14.0	20	18.5	1.25	0.80	3.8	2.2	47	BB6R/L-40140-GT125X	■	■	■	□	□
			22.0	30	28.5	1.25	0.80	3.8	2.2	57	BB6R/L-40220-GT125X	■	■	■	□	□
		4.5	16.0	20	18.5	1.25	0.90	4.28	2.4	47	BB6R/L-45160-GT125X	■	■	■	□	□
			25.0	30	28.5	1.25	0.90	4.28	2.4	57	BB6R/L-45250-GT125X	■	■	■	□	□
		5.0	17.5	20	18.5	1.25	1.00	4.75	2.5	47	BB6R/L-50175-GT125X	■	■	■	□	□
			27.5	30	28.5	1.25	1.00	4.75	2.5	57	BB6R/L-50275-GT125X	■	■	■	□	□
		5.5	17.5	20	18.5	1.25	1.10	5.15	2.6	47	BB6R/L-55175-GT125X	■	■	■	□	□
			27.5	30	28.5	1.25	1.10	5.15	2.6	57	BB6R/L-55275-GT125X	■	■	■	□	□

Fonçage-tournage

Einstechen und drehen

Grooving and turning

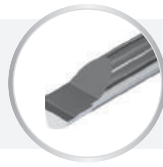

BF4... / BF6...

GTX

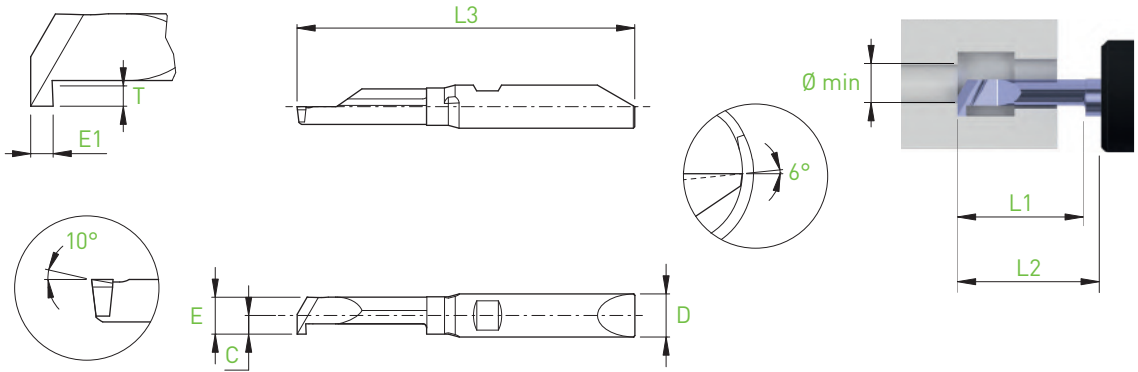

D h5	Holder	Ø min	L1	L2 BH4... BHY4...	L2 BHS4... BHK4...	E1	T	E	C	L3	Art. N°	R		L		
												ZTAF	ZTAXF	ZN	ZTAF	ZN
4	BH4... BHS4... BHY4... BHK4...	3.0	9.0	15	13.5	1.00	0.60	2.7	1.45	37	BF4R/L-3090-GT100X	■	■	■	□	□
			15.0	20	18.5	1.00	0.60	2.7	1.45	42	BF4R/L-30150-GT100X	■	■	■	□	□
	3.5	10.5	15	13.5	1.00	0.70	3.15	1.6	37	BF4R/L-35105-GT100X	■	■	■	□	□	
		17.5	20	18.5	1.00	0.70	3.15	1.6	42	BF4R/L-35175-GT100X	■	■	■	□	□	
D h5	Holder	Ø min	L1	L2 BH6... BHY6...	L2 BHS6... BHK6...	E1	T	E	C	L3	Art. N°	ZTAF	ZTAXF	ZN	ZTAF	ZN
6	BH6... BHS6... BHY6... BHK6...	4.0	14.0	20	18.5	1.25	0.80	3.8	2.2	47	BF6R/L-40140-GT125X	■	■	■	□	□
			22.0	30	28.5	1.25	0.80	3.8	2.2	57	BF6R/L-40220-GT125X	■	■	■	□	□
		4.5	16.0	20	18.5	1.25	0.90	4.28	2.4	47	BF6R/L-45160-GT125X	■	■	■	□	□
			25.0	30	28.5	1.25	0.90	4.28	2.4	57	BF6R/L-45250-GT125X	■	■	■	□	□
		5.0	17.5	20	18.5	1.25	1.00	4.75	2.5	47	BF6R/L-50175-GT125X	■	■	■	□	□
			27.5	30	28.5	1.25	1.00	4.75	2.5	57	BF6R/L-50275-GT125X	■	■	■	□	□
		5.5	17.5	20	18.5	1.25	1.10	5.15	2.6	47	BF6R/L-55175-GT125X	■	■	■	□	□
			27.5	30	28.5	1.25	1.10	5.15	2.6	57	BF6R/L-55275-GT125X	■	■	■	□	□

■ = disponible / verfügbar / available

□ = selon disponibilité du stock / jenach Lagerverfügbarkeit / depending the stock availability

# IN-LINE

Filetage  
Gewindedrehen  
Threading

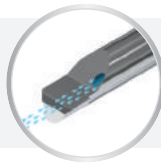

BB4... / BB6...

TP60

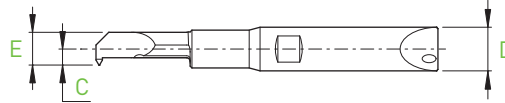
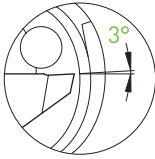
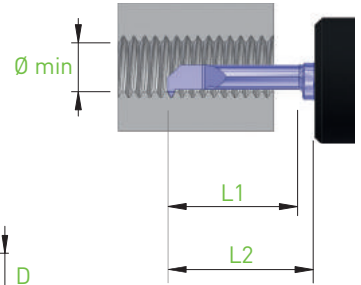
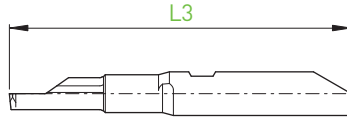
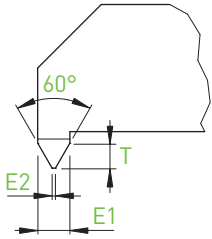

D h5	Holder	Ø min	L1	L2 BH4... BHY4...	L2 BHS4... BHK4...	P (mm)	P (TPI)	E1	E2 (0/-0.01)	T	E	C	L3	Art. N°	R		L	
															ZTAF	ZN	ZTAF	ZN
4	BH4... BHS4... BHY4... BHK4...	1.25	3.2	10	8.5	0.20-0.35	80	0.30	0.02	0.25	1.10	0.80	32	BB4R/L-1232-TP60	■	■	□	□
		1.6	4.0	10	8.5	0.25-0.40	72-64	0.35	0.03	0.28	1.41	0.90	32	BB4R/L-1640-TP60	■	■	□	□
		2.5	6.0	10	8.5	0.35-0.50	56-48	0.44	0.04	0.34	2.25	1.35	32	BB4R/L-2560-TP60	■	■	□	□
			9.0	15	13.5	0.35-0.50	56-48	0.44	0.04	0.34	2.25	1.35	37	BB4R/L-2590-TP60	■	■	□	□
		3.3	8.0	15	13.5	0.50-0.75	40-36	0.62	0.06	0.48	2.97	1.50	37	BB4R/L-3380-TP60	■	■	□	□
12.0	15		13.5	0.50-0.75	40-36	0.62	0.06	0.48	2.97	1.50	37	BB4R/L-33120-TP60	■	■	□	□		
6	BH6... BHS6... BHY6... BHK6...	4.2	10.0	20	18.5	0.50-0.80	36-32	0.70	0.06	0.55	3.78	2.10	47	BB6R/L-42100-TP60	■	■	□	□
			15.0	20	18.5	0.50-0.80	36-32	0.70	0.06	0.55	3.78	2.10	47	BB6R/L-42150-TP60	■	■	□	□
		5.0	12.0	20	18.5	0.75-1.00	28-24	0.89	0.09	0.69	4.50	2.20	47	BB6R/L-50120-TP60	■	■	□	□
			18.0	20	18.5	0.75-1.00	28-24	0.89	0.09	0.69	4.50	2.20	47	BB6R/L-50180-TP60	■	■	□	□



**Filetage**  
**Gewindedrehen**  
**Threading**

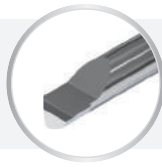

**BF4... / BF6...**

**TP60**

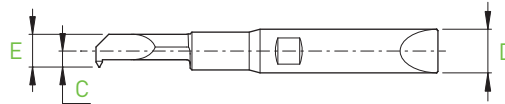
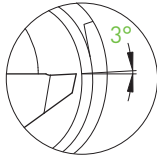
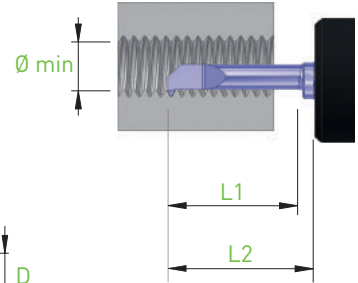
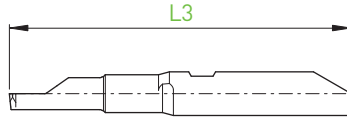
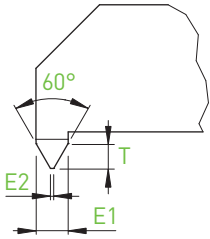

D <sub>h5</sub>	Holder	Ø min	L1	L2 BH4... BHY4...	L2 BHS4... BHK4...	P (mm)	P (TPI)	E1	E2 (0/-0.01)	T	E	C	L3	Art. N°	R		L	
															ZTAF	ZN	ZTAF	ZN
4	BH4... BHS4... BHY4... BHK4...	1.25	3.2	10	8.5	0.20-0.35	80	0.30	0.02	0.25	1.10	0.80	32	BF4R/L-1232-TP60	■	■	□	□
		1.6	4.0	10	8.5	0.25-0.40	72-64	0.35	0.03	0.28	1.41	0.90	32	BF4R/L-1640-TP60	■	■	□	□
		2.5	6.0	10	8.5	0.35-0.50	56-48	0.44	0.04	0.34	2.25	1.35	32	BF4R/L-2560-TP60	■	■	□	□
			9.0	15	13.5	0.35-0.50	56-48	0.44	0.04	0.34	2.25	1.35	37	BF4R/L-2590-TP60	■	■	□	□
		3.3	8.0	15	13.5	0.50-0.75	40-36	0.62	0.06	0.48	2.97	1.50	37	BF4R/L-3380-TP60	■	■	□	□
12.0	15		13.5	0.50-0.75	40-36	0.62	0.06	0.48	2.97	1.50	37	BF4R/L-33120-TP60	■	■	□	□		
6	BH6... BHS6... BHY6... BHK6...	4.2	10.0	20	18.5	0.50-0.80	36-32	0.70	0.06	0.55	3.78	2.10	47	BF6R/L-42100-TP60	■	■	□	□
			15.0	20	18.5	0.50-0.80	36-32	0.70	0.06	0.55	3.78	2.10	47	BF6R/L-42150-TP60	■	■	□	□
		5.0	12.0	20	18.5	0.75-1.00	28-24	0.89	0.09	0.69	4.50	2.20	47	BF6R/L-50120-TP60	■	■	□	□
			18.0	20	18.5	0.75-1.00	28-24	0.89	0.09	0.69	4.50	2.20	47	BF6R/L-50180-TP60	■	■	□	□

■ = disponible / verfügbar / available  
□ = selon disponibilité du stock / jenach Lagerverfügbarkeit / depending the stock availability

# IN-LINE

Filetage  
Gewindedrehen  
Threading

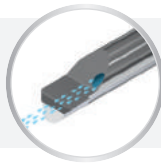

BB4... / BB6...

TP55

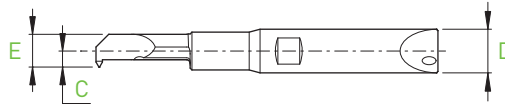
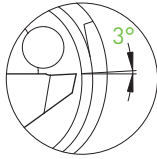
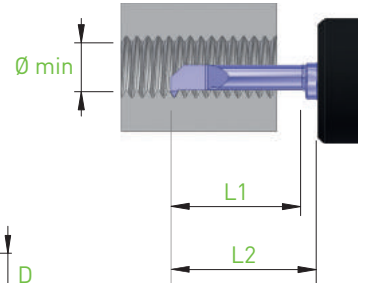
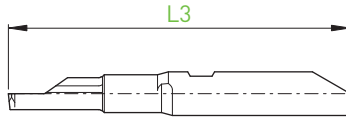
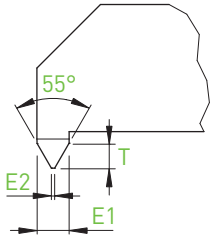

D <sub>h5</sub>	Holder	Ø min	L1	L2 BH4... BHY4...	L2 BHS4... BHK4...	P (TPI)	E1	E2 [0/-0.02]	T	E	C	L3	Art. N°	R		L	
														ZTAF	ZN	ZTAF	ZN
4	BH4...	1.85	4.5	10	8.5	48	0.54	0.09	0.44	1.67	0.97	32	BB4R/L-1845-TP55	■	■	□	□
	BHS4...																
	BHY4... BHK4...	2.55	6.0	10	8.5	40	0.64	0.10	0.52	2.25	1.35	32	BB4R/L-2560-TP55	■	■	□	□
D <sub>h5</sub>	Holder	Ø min	L1	L2 BH6... BHY6...	L2 BHS6... BHK6...	P (TPI)	E1	E2 [0/-0.02]	T	E	C	L3	Art. N°	ZTAF	ZN	ZTAF	ZN
6	BH6...	3.70	11.0	20	18.5	32-24	1.08	0.13	0.91	3.33	1.83	47	BB6R/L-37110-TP55	■	■	□	□
	BHS6...	5.10	15.0	20	18.5	26-20	1.30	0.16	1.09	4.60	2.05	47	BB6R/L-51150-TP55	■	■	□	□
	BHY6...																
	BHK6...	5.50	16.0	20	18.5	22-16	1.48	0.19	1.24	5.15	2.60	47	BB6R/L-55160-TP55	■	■	□	□

Filetage  
Gewindedrehen  
Threading



BF4... / BF6...

TP55

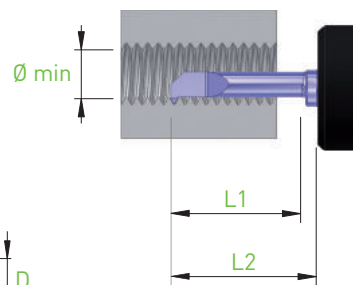
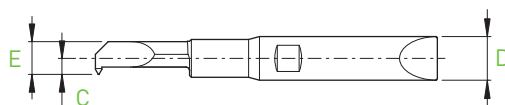
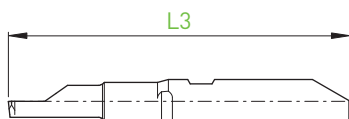
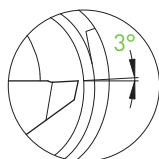
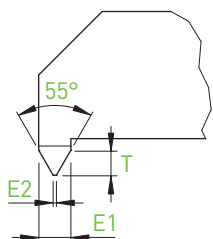

D <sub>h5</sub>	Holder	Ø min	L1	L2 BH4... BHY4...	L2 BHS4... BHK4...	P (TPI)	E1	E2 (0/-0.02)	T	E	C	L3	Art. N°	R		L	
														ZTAF	ZN	ZTAF	ZN
4	BH4...	1.85	4.5	10	8.5	48	0.54	0.09	0.44	1.67	0.97	32	BF4R/L-1845-TP55	■	■	□	□
	BHS4...																
	BHY4... BHK4...	2.55	6.0	10	8.5	40	0.64	0.10	0.52	2.25	1.35	32	BF4R/L-2560-TP55	■	■	□	□
D <sub>h5</sub>	Holder	Ø min	L1	L2 BH6... BHY6...	L2 BHS6... BHK6...	P (TPI)	E1	E2 (0/-0.02)	T	E	C	L3	Art. N°	ZTAF	ZN	ZTAF	ZN
6	BH6...	3.70	11.0	20	18.5	32-24	1.08	0.13	0.91	3.33	1.83	47	BF6R/L-37110-TP55	■	■	□	□
	BHS6...	5.10	15.0	20	18.5	26-20	1.30	0.16	1.09	4.60	2.05	47	BF6R/L-51150-TP55	■	■	□	□
	BHY6...																
	BHK6...	5.50	16.0	20	18.5	22-16	1.48	0.19	1.24	5.15	2.60	47	BF6R/L-55160-TP55	■	■	□	□

■ = disponible / verfügbar / available  
□ = selon disponibilité du stock / jenach Lagerverfügbarkeit / depending the stock availability

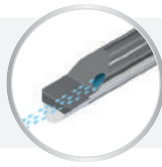

Profil complet métrique  
Metrisches Vollprofil  
Metric full profile

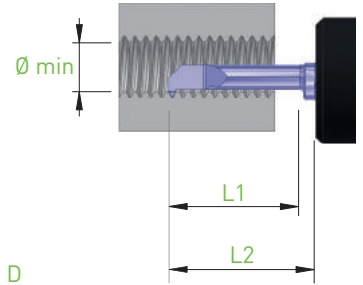
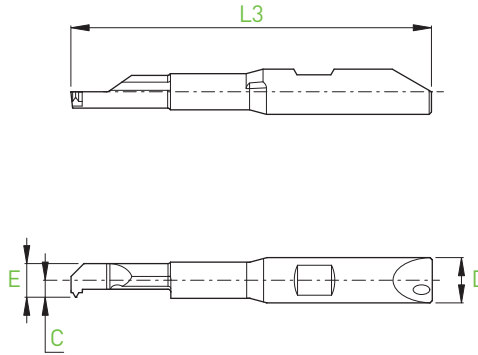
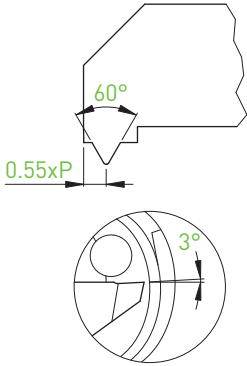

D <sub>h5</sub>	Holder	M (min)	Ø min	P (mm)	L1	L2 BH4... BHY4...	L2 BHS4... BHK4...	E	C	L3	Art. N°	R	
												ZTAF	ZN
4	BH4... BHS4... BHY4... BHK4...	M3x0.5	2.50	0.50	6.0	10	8.5	2.25	1.35	32	BB4R-2560-TM-0.50	■	■
		M4x0.7	3.30	0.70	8.0	15	13.5	2.97	1.50	37	BB4R-3380-TM-0.70	■	■
D <sub>h5</sub>	Holder	M (min)	Ø min	P (mm)	L1	L2 BH6... BHY6...	L2 BHS6... BHK6...	E	C	L3	Art. N°	R	
												ZTAF	ZN
6	BH6... BHS6... BHY6... BHK6...	M5x0.8	4.20	0.80	10.0	20	18.5	3.78	2.10	47	BB6R-42100-TM-0.80	■	■
		M6x1.0	5.00	1.00	12.0	20	18.5	4.50	2.20	47	BB6R-50120-TM-1.00	■	■

Filetage  
Gewindedrehen  
Threading

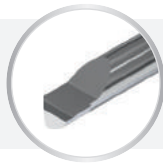

BF4... / BF6...

TM

Profil complet métrique  
Metrisches Vollprofil  
Metric full profile

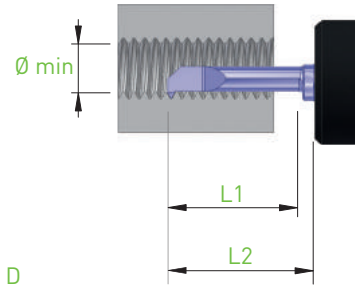
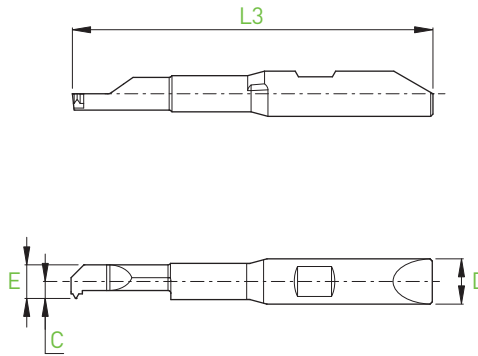
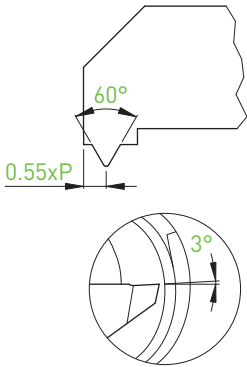

R

D h5	Holder	M (min)	Ø min	P (mm)	L1	L2 BH4... BHY4...	L2 BHS4... BHK4...	E	C	L3	Art. N°	ZTAF	ZN
4	BH4... BHS4... BHY4... BHK4...	M3x0.5	2.50	0.50	6.0	10	8.5	2.25	1.35	32	BF4R-2560-TM-0.50	■	■
		M4x0.7	3.30	0.70	8.0	15	13.5	2.97	1.50	37	BF4R-3380-TM-0.70	■	■
D h5	Holder	M (min)	Ø min	P (mm)	L1	L2 BH6... BHY6...	L2 BHS6... BHK6...	E	C	L3	Art. N°	ZTAF	ZN
6	BH6... BHS6... BHY6... BHK6...	M5x0.8	4.20	0.80	10.0	20	18.5	3.78	2.10	47	BF6R-42100-TM-0.80	■	■
		M6x1.0	5.00	1.00	12.0	20	18.5	4.50	2.20	47	BF6R-50120-TM-1.00	■	■

# IN-LINE

- Gorge frontale extérieure
- Aussen axiales stechen
- External axial grooving

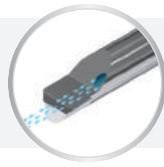

BB6...

FEG

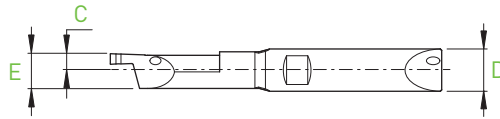
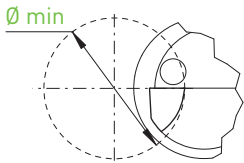
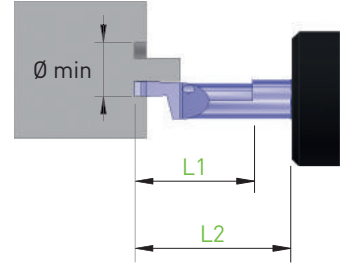
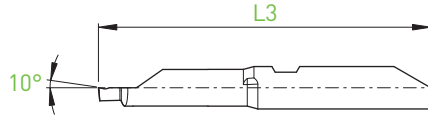
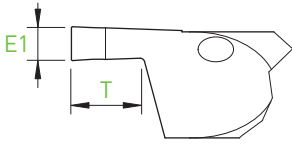

R

D h5	Holder	Ø min	L1	L2 BH6... BHY6...	L2 BHS6... BHK6...	T	E	C	E1	L3	Art. N°	ZTAF	ZN
6	BH6... BHS6... BHY6... BHK6...	5.0	15.0	20	18.5	3.00	4.90	2.30	1.50	47	BB6R-50150-FEG150X	■	■

P  
 M  
 N  
 S  
 P  
 N  
 S  
 ZTAF  
 ZN

Gorge frontale intérieure

Innen axiales stechen

Internal axial grooving

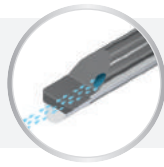

BB6...

FIG

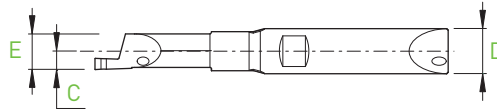
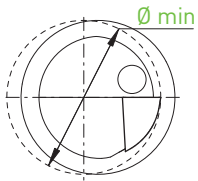
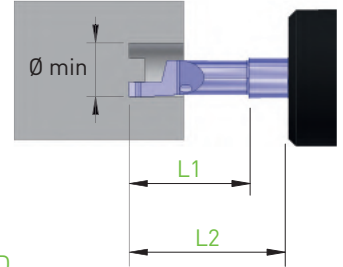
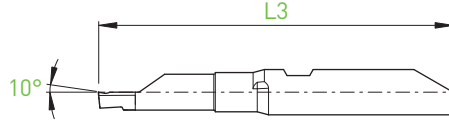
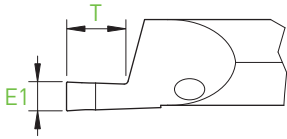

R

D h5	Holder	Ø min	L1	L2 BH6... BHY6...	L2 BHS6... BHK6...	T	E	C	E1	L3	Art. N°	ZTAF	ZN
6	BH6... BHS6... BHY6... BHK6...	5.0	15.0	20	18.5	3.00	4.75	2.45	1.50	47	BB6R-50150-FIG150X	■	■

■ = disponible / verfügbar / available

□ = selon disponibilité du stock / jenach Lagerverfügbarkeit / depending the stock availability

# IN-LINE

Ébauches avec arrosage  
 Rohlinge mit Kühlung  
 Blanks with coolant

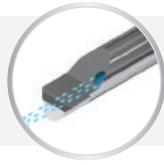

**BB4... / BB6...**

**BB\_E**

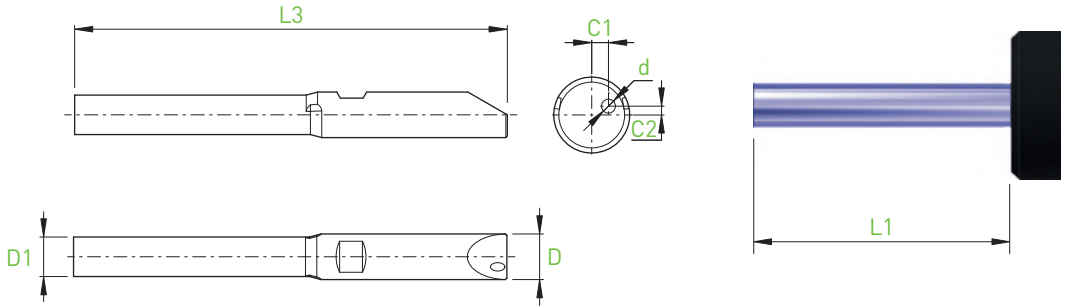

$D_{h5}$	Holder	L1 BH4... BHY4...	L1 BHS4... BHK4...	$D1$	$C1$	$C2$	$d$	$L3$	Art. N°	ZN
4	BH4... BHS4... BHY4... BHK4...	20.0	18.5	3.20	0.84	0.55	0.85	42	BB4R-E42	■
$D_{h5}$	Holder	L1 BH6... BHY6...	L1 BHS6... BHK6...	$D1$	$C1$	$C2$	$d$	$L3$	Art. N°	ZN
6	BH6... BHS6... BHY6... BHK6...	30.0	28.5	5.20	1.33	0.70	1.10	57	BB6R-E57	■



Ébauches

Rohlinge

Blanks

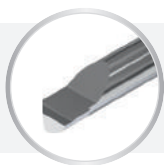

BF4... / BF6...

BF\_E

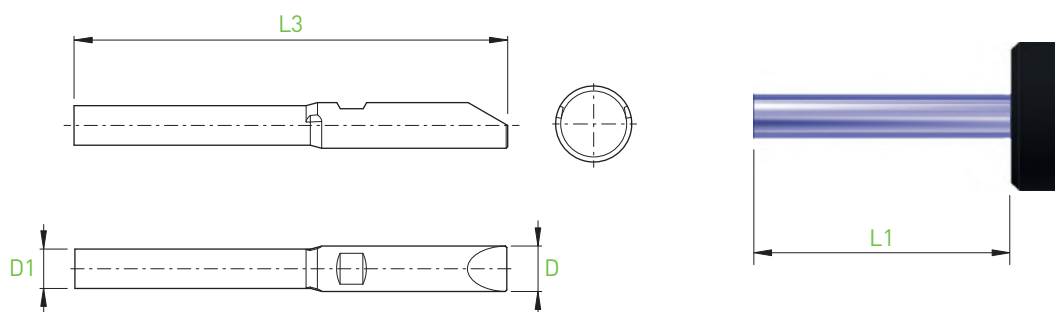

D h5	Holder	L1 BH4... BHY4...	L1 BHS4... BHK4...	D1	L3	Art. N°	ZN
4	BH4... BHS4... BHY4... BHK4...	20.0	18.5	3.20	42	BF4-E42	■
D h5	Holder	L1 BH6... BHY6...	L1 BHS6... BHK6...	D1	L3	Art. N°	ZN
6	BH6... BHS6... BHY6... BHK6...	30.0	28.5	5.20	57	BF6-E57	■

# IN-LINE

Jauges d'alignement

Richtplatten

Adjusting tools

## MASTER

## BH4 / BH6

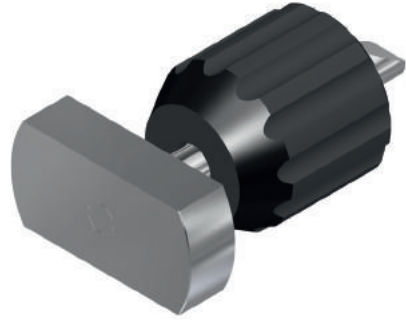
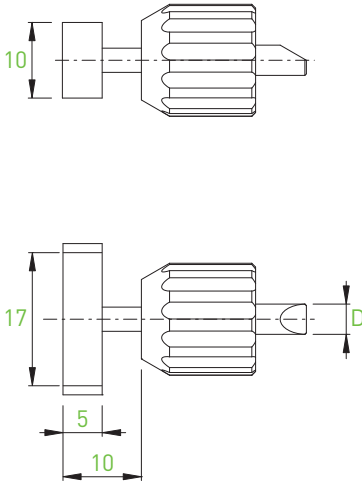

D h5	Art. N°	
4	BH4-MASTER	■
6	BH6-MASTER	■

Jauges d'alignement

Richtplatten

Adjusting tools

## MASTER

## BHSY...

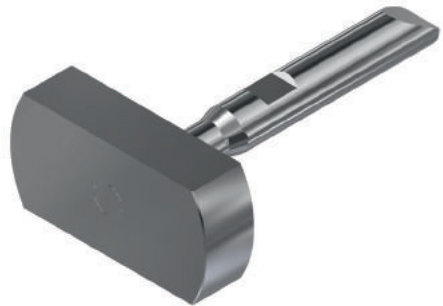
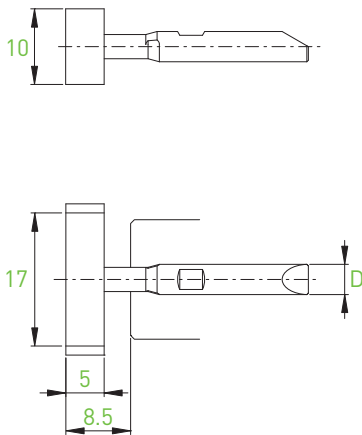

D h5	Art. N°	
4	BHSY4-MASTER	■
6	BHSY6-MASTER	■

Porte-outils avec arrosage pour contre-opération - Machines STAR  
 Halter mit Kühlungssystem für Gegenbearbeitung – STAR-Maschinen  
 Backworking holders with through coolant – STAR-Machines

BH4 / BH6  
 BHS4 / BHS6

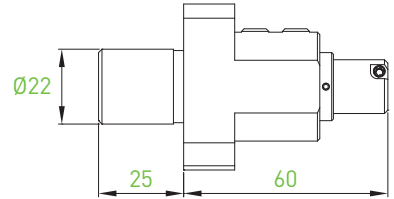
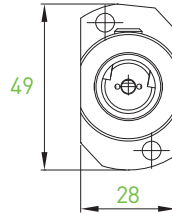

Art. N°

BWD1-2022-STAR-SRR

Art. N°

BHS4-D20-55-BWD1  
 BHS6-D20-55-BWD1

Types of STAR machines

SR10J (T22+T24)  
 SB16/20 Types C + D + E (T21-T24)  
 SB20R Types E + G + N (T21-T24)  
 SR20J / JN (T21-T24)  
 SR20R / II / III (T21-T24)  
 SR20R IV (T21-T24)  
 SR32J/JN (T21-T24)  
 SW12RII (T21-T24)  
 SV20R (T21-T24)  
 ECAS12/20 (T21-T24)  
 SW20 (T21-T23)

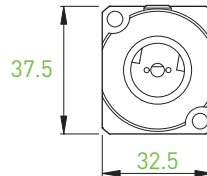
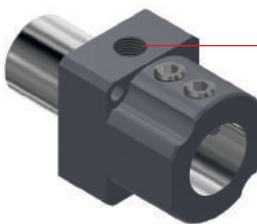

Art. N°

BWD1-2022-STAR-SW

Art. N°

BHS4-D20-55-BWD1  
 BHS6-D20-55-BWD1

Types of STAR machines

SW12RII (T21-T28)  
 SW20 (T21-T23 + T25-T27)  
 SV20R (T21-T28)  
 SR-20R IV (T21-T28)  
 SB12/20R (T22-T24)  
 SR38 (T21-T28)

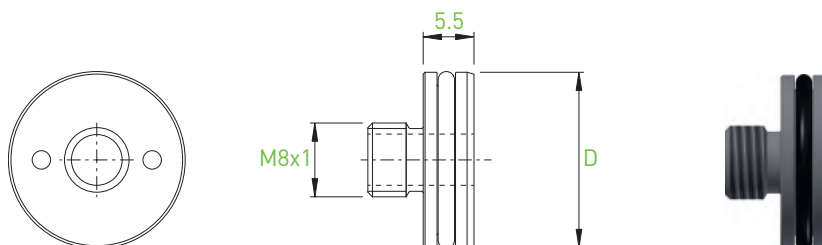
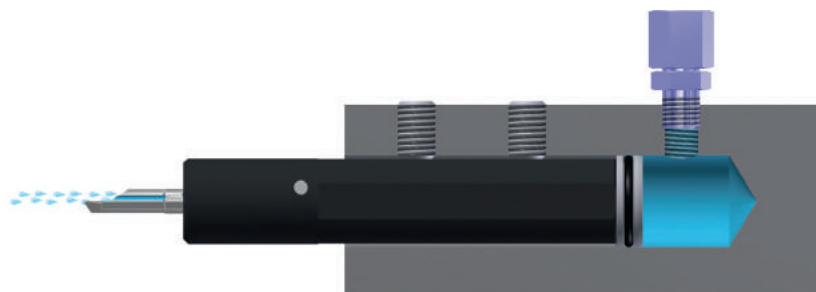

D	Art. N°	
19.05	JB-M8X1-D19.05	■
20	JB-M8X1-D20	■
22	JB-M8X1-D22	■
25	JB-M8X1-D25	■
25.4	JB-M8X1-D25.4	■

# JET-LINE

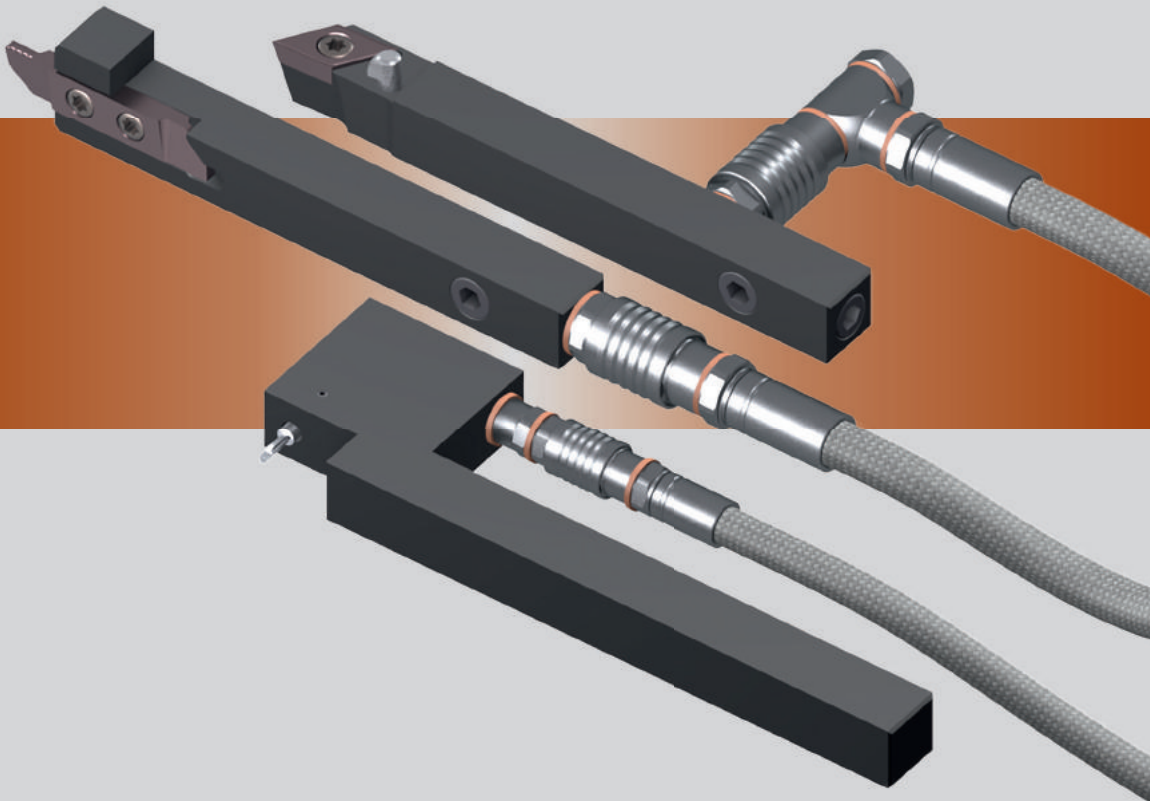

DISCOVER JET-LINE IN CHAPTER 16!

Avantages  
Vorteile  
Advantages

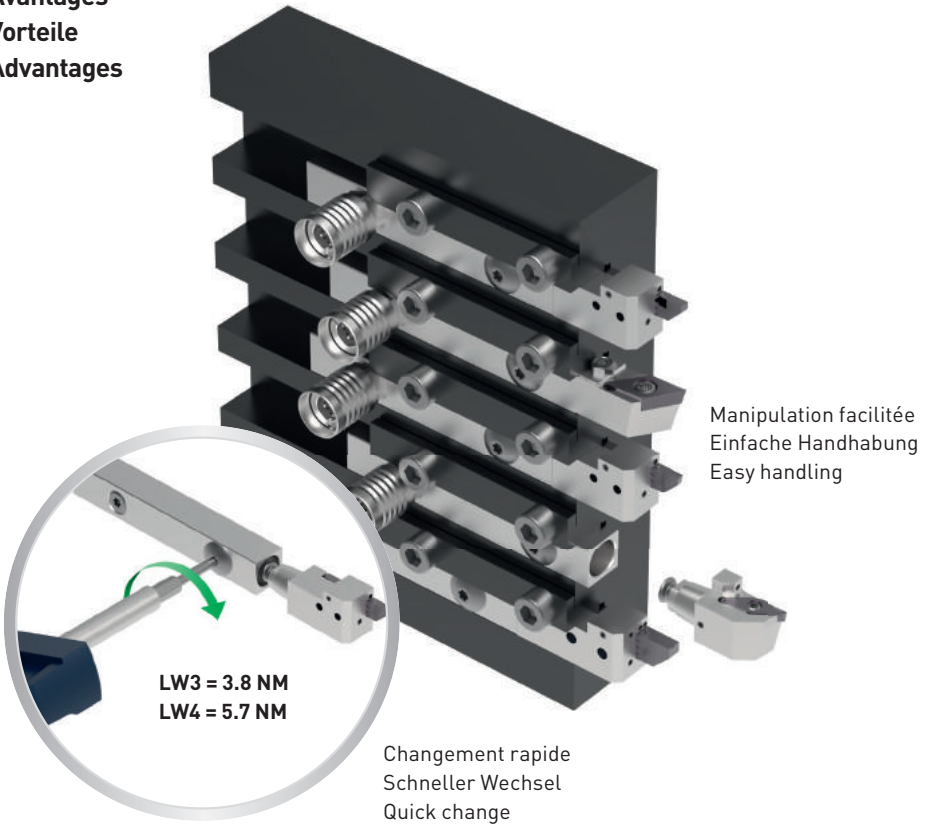

Lubrification intégrée  
Integrierte Kühlung  
Integrated coolant

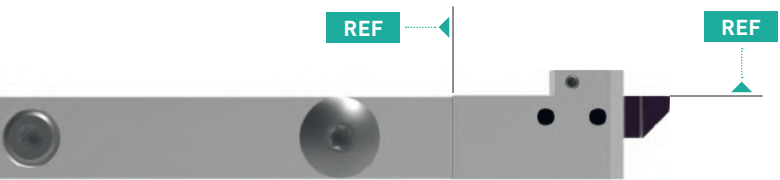
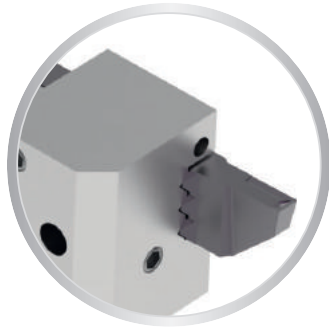

Excellente répétabilité  
Ausgezeichnete  
Wiederholgenauigkeit  
Excellent repeatability

INFO > **11.02**

Supports carrés  
Viereckige Halter  
Square holders



> **11.05**

Têtes interchangeables | Wechsetköpfe | Interchangeable heads

TOP-Line



LW-730-740

> **11.06**

LW-750-760

> **11.07**

LW-770-780

> **11.08**

TURN-Line



88°

LW-310-320

> **11.09**

LW-310-BC/320-BC

> **11.10**

85°

LW-330-340

> **11.11**

ISO-Line



80°

LW-SCL

> **11.12**

LW-SCM

> **11.13**

55°

LW-SDJ

> **11.14**

LW-SDN

> **11.15**

LW-SDH

> **11.16**

35°

LW-SVJ

> **11.17**

LW-SVV

> **11.18**

Supports cylindriques  
Zylindrische Halter  
Cylinder holders



> **11.19**

Têtes interchangeables porte-pince  
Spannzangenwechsetköpfe  
Interchangeable head gripper holder



> **11.20**

Porte-outils  
Halter  
Holders



> **11.21**

# SWITCH-LINE

Désignations - Carrés  
 Bezeichnungen - Quadrat  
 Designation - Square

INFO

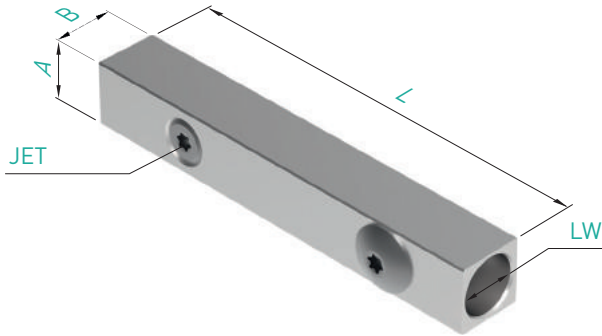

LW	A x B	L	JET
Interface	Section	Longueur Länge Length	Arrosage intégré Integrierte Kühlung Integrated coolant

Désignations - Têtes interchangeables  
 Bezeichnungen - Wechselköpfe  
 Designation - Interchangeable heads

INFO

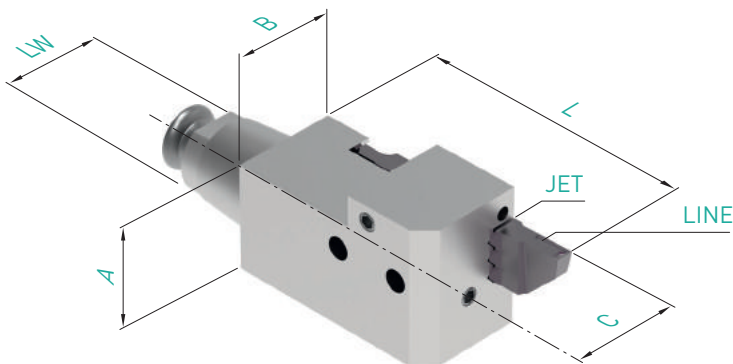

LW	LINE	A x B	C	L	JET
Interface	Serie	Section	Localisation axe Achselokalisation Axis location	Longueur Länge Length	Arrosage intégré Integrierte Kühlung Integrated coolant



Désignations - Cylindres

Bezeichnungen - Zylinder

Designations - Cylinder

INFO

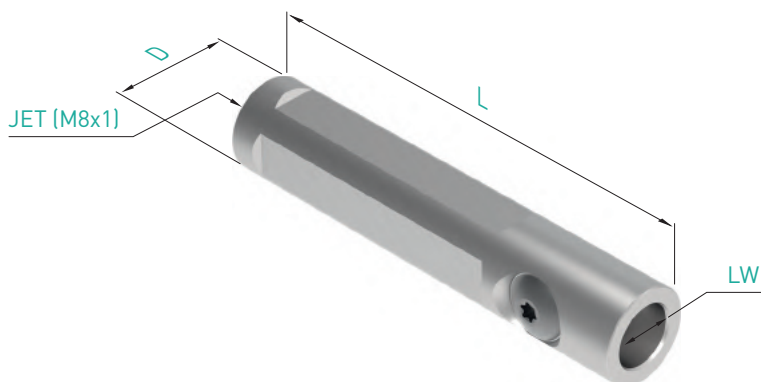

LW	D	L	JET
Interface	∅	Longueur Länge Length	Arrosage intégré Integrierte Kühlung Integrated coolant

Désignations - Têtes porte-pinces

Bezeichnungen - Spannzangenköpfe

Designation - Gripper holder heads

INFO

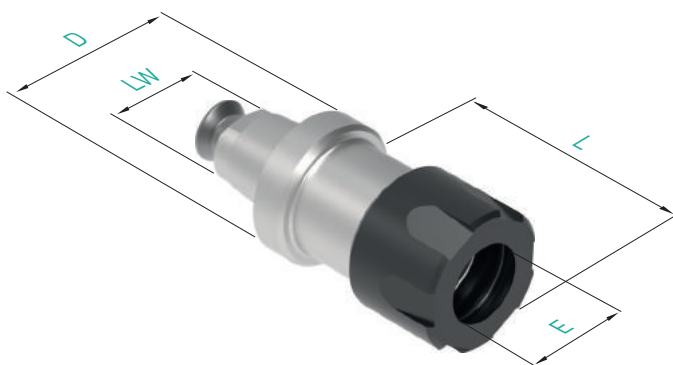

LW	E	D	L
Interface	Pince type Spannzange Typ Gripper type	∅	Longueur Länge Length

# SWITCH-LINE

Désignations - HSK  
 Bezeichnungen - HSK  
 Designation - HSK

INFO

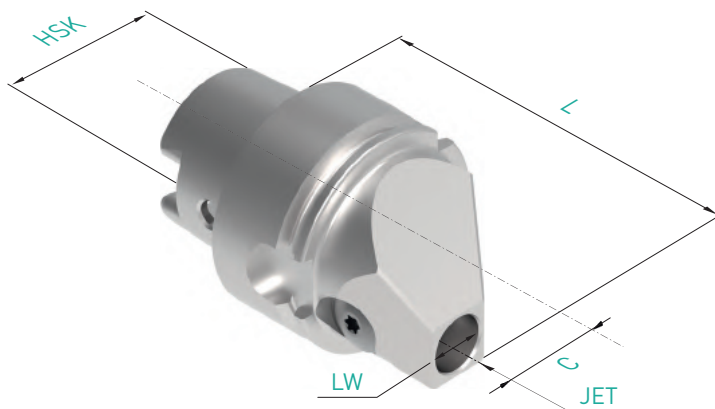

HSK	LW	C	L	JET	X
Machine interface	Interface tête interchangeable Wechselkopfschnittstelle Interchangeable head interface	Localisation axe Achsellokalisierung Axis location LW	Longueur Länge Length	Arrosage intégré Integrierte Kühlung Integrated coolant	Spécificité fabricant machine Spezifität Maschinenhersteller Specificity machine manufacturer

Supports carrés  
 Viereckige Halter  
 Square holders

LW-JET

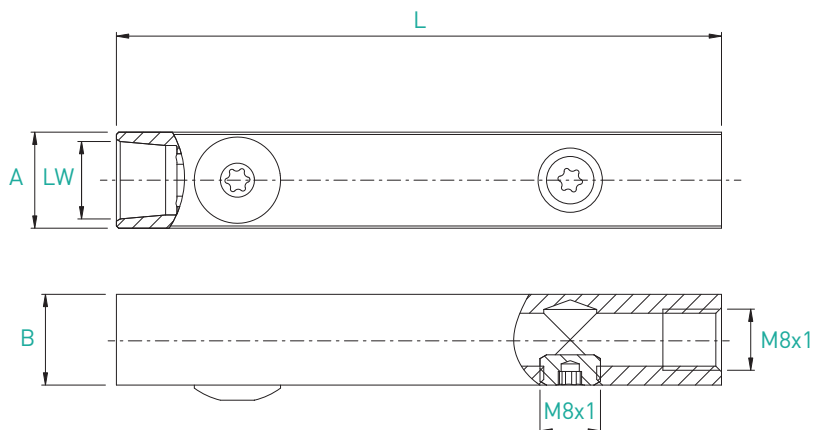

Pièces rechanges Ersatzteile Spare parts		Options	

LW	A x B	L	Art. N°	Art. N°	Art. N°	Art. N°	Art. N°
LW3	12x12	80	LW3-1212-80-JET	JB-M8X1	LW3-ER1.012.014	CD-NM3.8	TX15-E6.3
LW3	12.7x12	80	LW3-12.7-80-JET				
LW4	15.87x16	25	LW4-15.87-80-JET	JB-M8X1	LW4-ER1.014.019	CD-NM5.7	TX20-E6.3
LW4	16x16	25	LW4-1616-80-JET				



Utilisation clé dynamométrique recommandée  
 Benutzung eines Drehmomentschlüssels empfohlen  
 Recommended use of dynamometric key

Options	
	<b>Art. N°</b>
	<b>M8X1</b> voir JET-LINE siehe JET-LINE see JET-LINE

# SWITCH-LINE



Têtes interchangeables  
Wechselköpfe  
Interchangeable heads

TOP-Line

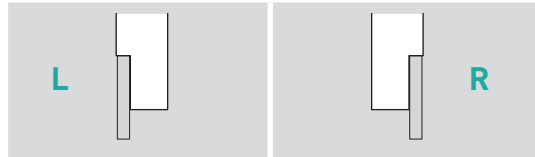
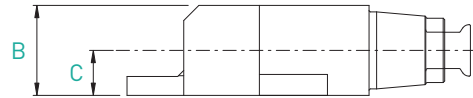
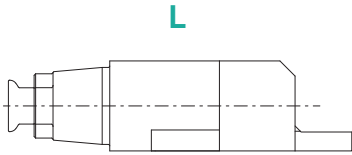
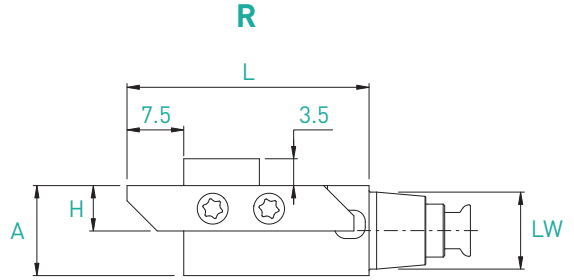
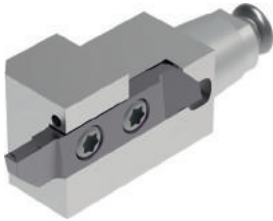
LW-730/740-JET

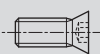

Plaquettes WSP Inserts	LW	A x B	H	C	L	Art. N°	
73_-74_	LW3	12x12	6	6	32	LW3-730-12-0632-JET	LW3-740-12-0632-JET
	LW4	16x16	8	8	32	LW4-730-16-0832-JET	LW4-740-16-0832-JET

Pièces de rechange Ersatzteile Spare parts	LW			
		Art. N°	Art. N°	Art. N°
		LW3	V-M3X7-T8	C-T8
LW4			LW4-U00.ER1.000	

Têtes interchangeables

Wechselköpfe



Interchangeable heads

TOP-Line

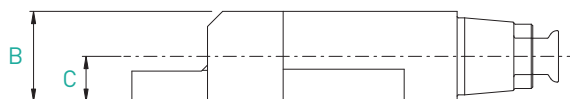
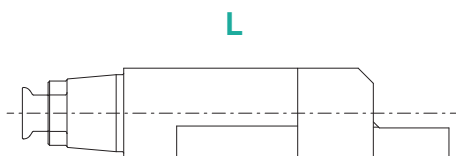
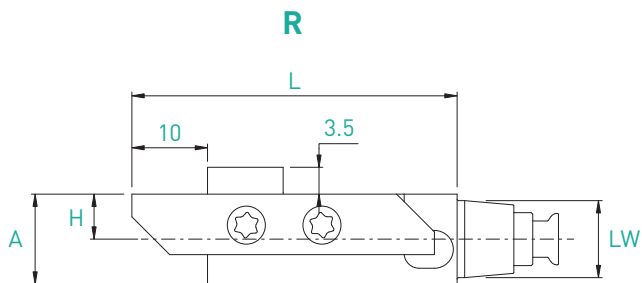
LW-750/760-JET

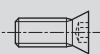

Plaquettes WSP Inserts	LW	A x B	H	C	L	Art. N°	
						Art. N°	Art. N°
75_-76_	LW3	12x12	6	6	43	LW3-750-12-0643-JET	LW3-760-12-0643-JET
	LW4	16x16	8	8	43	LW4-750-16-0843-JET	LW4-760-16-0843-JET

Pièces de rechange Ersatzteile Spare parts	LW			
		Art. N°	Art. N°	Art. N°
		LW3	V-M4X9-T15	C-T15
LW4			LW4-U00.ER1.000	

# SWITCH-LINE

Têtes interchangeables  
Wechselköpfe  
Interchangeable heads

TOP-Line

LW-770/780-JET

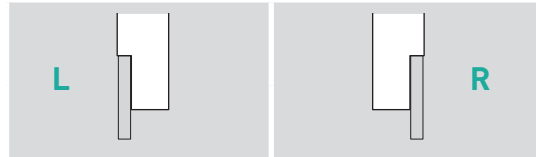
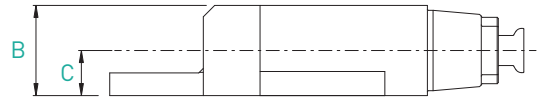
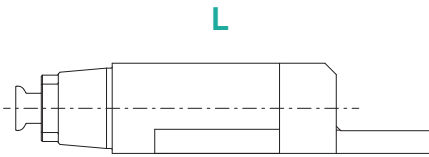
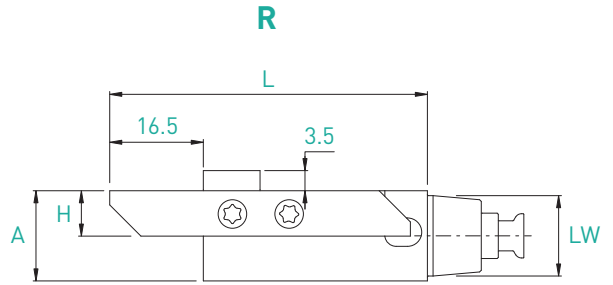
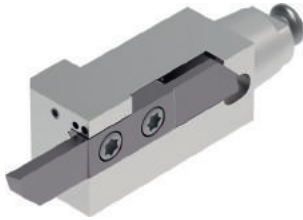

Plaquettes WSP Inserts	LW	A x B	H	C	L	Art. N°	Art. N°
77_-78_	LW4	16x16	8	8	56	LW4-770-16-0856-JET	LW4-780-16-0856-JET

Pièces de rechange Ersatzteile Spare parts	LW	Art. N°	Art. N°	Art. N°
	LW4	V-M4X9-T15	C-T15	LW4-U00.ER1.000

Têtes interchangeables

Wechselköpfe



Interchangeable heads

TURN-Line 88°

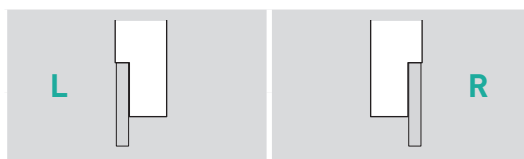
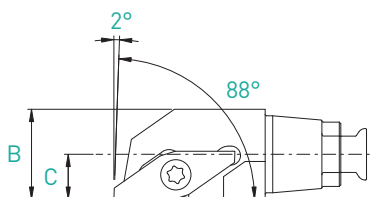
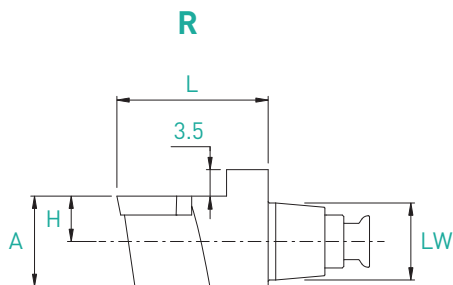
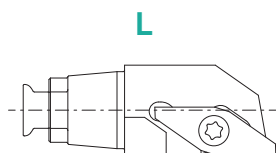
LW-310/320-JET

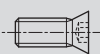

Plaquettes WSP Inserts	LW	A x B	H	C	L	Art. N°	
						Art. N°	Art. N°
31_-32_	LW3	12x12	6	6	20	LW3-310-12-0620-JET	LW3-320-12-0620-JET
	LW4	16x16	8	8	25	LW4-310-16-0825-JET	LW4-320-16-0825-JET

Pièces de rechange Ersatzteile Spare parts	LW			
		Art. N°	Art. N°	Art. N°
	LW3	V-M2.5X7.8-T8	C-T8	LW3-U00.ER1.000
	LW4			LW4-U00.ER1.000

# SWITCH-LINE

Têtes interchangeables  
Wechselköpfe  
Interchangeable heads



**TURN-Line**

**88°**

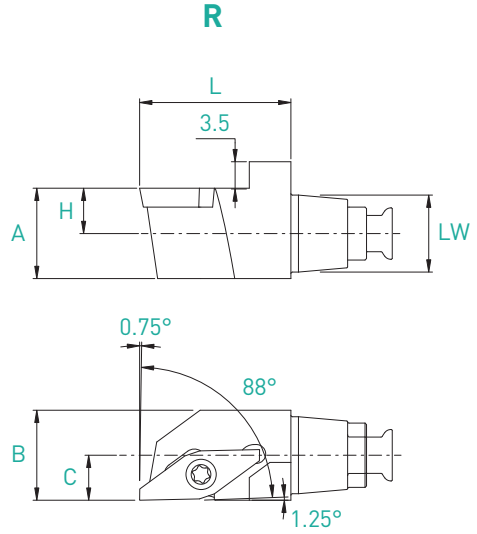
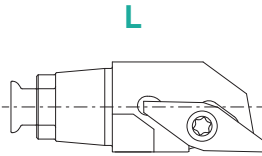
**LW-310-BC/320-BC-JET**

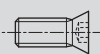

Plaquettes WSP Inserts	LW	A x B	H	C	L	Art. N°	
						L	R
31_-32_	LW3	12x12	6	6	20	LW3-310-12-0620-BC-JET	LW3-320-12-0620-BC-JET
	LW4	16x16	8	8	25	LW4-310-16-0825-BC-JET	LW4-320-16-0825-BC-JET

Pièces de rechange Ersatzteile Spare parts	LW			
		Art. N°	Art. N°	Art. N°
LW3	V-M2.5X7.8-T8	C-T8	LW3-U00.ER1.000	
LW4			LW4-U00.ER1.000	





Têtes interchangeables  
 Wechselköpfe  
 Interchangeable heads

TURN-Line 85°

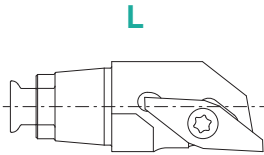
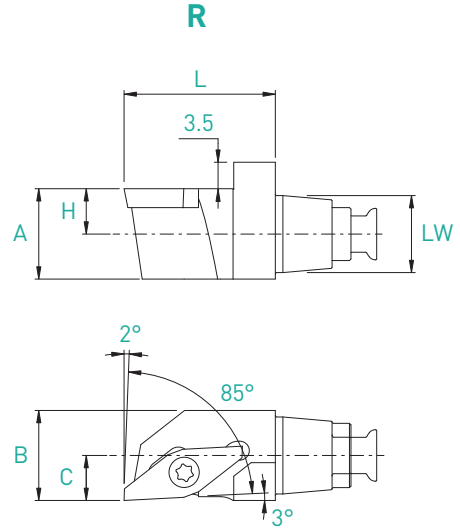
LW-330/340-JET

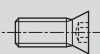

Plaquettes WSP Inserts	LW	A x B	H	C	L	Art. N°	
						Art. N°	Art. N°
33_-34_	LW3	12x12	6	6	20	LW3-330-12-0620-JET	LW3-340-12-0620-JET
	LW4	16x16	8	8	25	LW4-330-16-0825-JET	LW4-340-16-0825-JET

Pièces de rechange Ersatzteile Spare parts	LW			
		Art. N°	Art. N°	Art. N°
		LW3	V-M2.5X7.8-T8	C-T8
LW4			LW4-U00.ER1.000	

# SWITCH-LINE

Têtes interchangeables  
Wechselköpfe  
Interchangeable heads

ISO-Line 80°

LW-SCL-JET

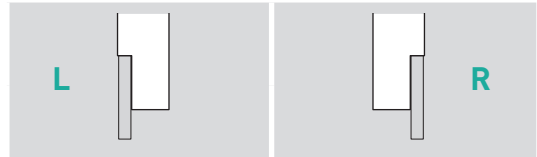
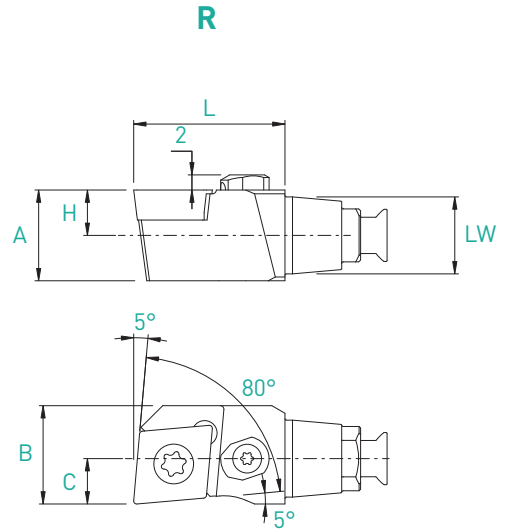
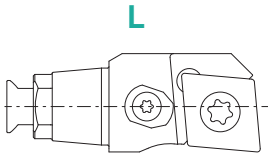

Plaquettes WSP Inserts	LW	A x B	H	C	L	Art. N°	
						Art. N°	Art. N°
CC...-0602..	LW3	12x12	6	6	20	LW3-SCLCL-12-0620-06-JET	LW3-SCLCR-12-0620-06-JET
	LW4	16x16	8	8	25	LW4-SCLCL-16-0825-06-JET	LW4-SCLCR-16-0825-06-JET
CC...-09T3..	LW3	12x12	6	6	20	LW3-SCLCL-12-0620-09-JET	LW3-SCLCR-12-0620-09-JET
	LW4	16x16	8	8	25	LW4-SCLCL-16-0825-09-JET	LW4-SCLCR-16-0825-09-JET

Pièces de rechange Ersatzteile Spare parts	Plaquettes WSP Inserts	LW	Art. N°			
			Art. N°	Art. N°	Art. N°	Art. N°
	CC...-0602..	LW3	V-M2.5X7.8-T8	C-T8	LWX-ER1.007.002	LW3-U00.ER1.000
		LW4				LW4-U00.ER1.000
	CC...-09T3..	LW3	V-M4X9-T15-ISO	C-T15		LW3-U00.ER1.000
		LW4				LW4-U00.ER1.000

Têtes interchangeables

Wechselköpfe

Interchangeable heads



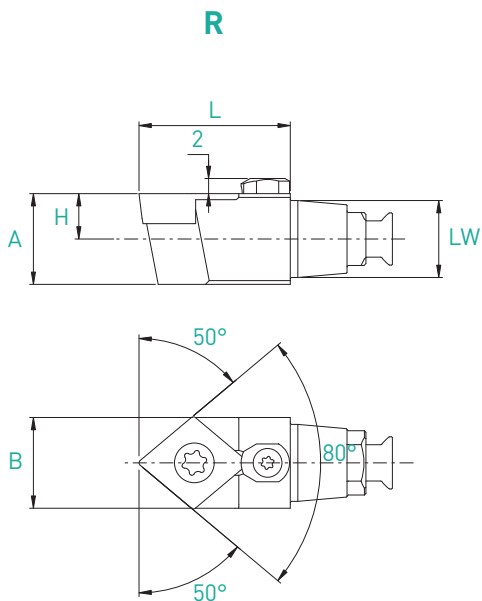

ISO-Line

80°

LW-SCM-JET

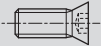

Plaquettes WSP Inserts	LW	A x B	H	L	Art. N°
CC...-0602..	LW3	12x12	6	20	LW3-SCMCN-12-0020-06-JET
	LW4	16x16	8	25	LW4-SCMCN-16-0025-06-JET
CC...-09T3..	LW3	12x12	6	20	LW3-SCMCN-12-0020-09-JET
	LW4	16x16	8	25	LW4-SCMCN-16-0025-09-JET

Pièces de rechange Ersatzteile Spare parts	Plaquettes WSP Inserts	LW				
			Art. N°	Art. N°	Art. N°	Art. N°
CC...-0602..	LW3	V-M2.5X7.8-T8	C-T8	LWX-ER1.007.002	LW3-U00.ER1.000	
	LW4				LW4-U00.ER1.000	
CC...-09T3..	LW3	V-M4X9-T15-ISO	C-T15	LWX-ER1.007.002	LW3-U00.ER1.000	
	LW4				LW4-U00.ER1.000	

# SWITCH-LINE

Têtes interchangeables  
Wechselköpfe  
Interchangeable heads

ISO-Line 55°

LW-SDJ-JET

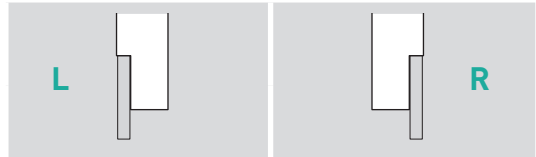
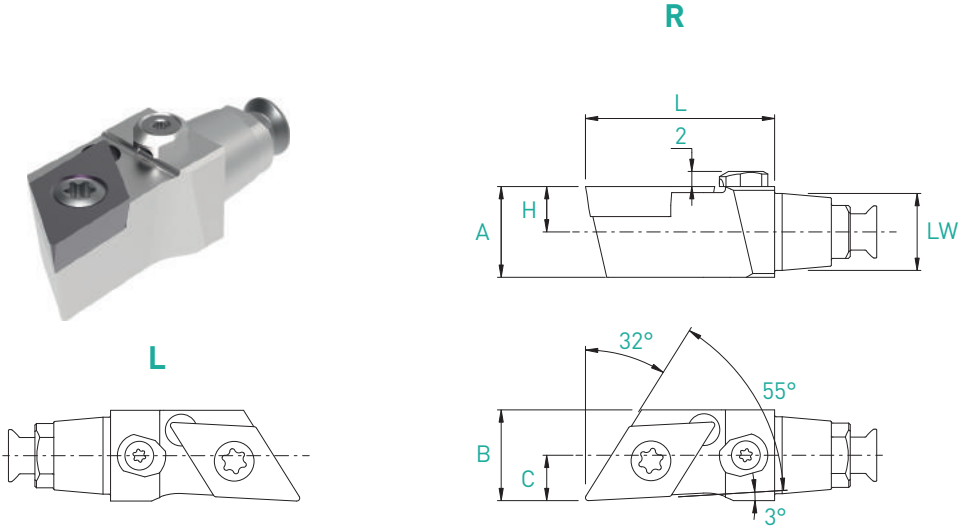

Plaquettes WSP Inserts	LW	A x B	H	C	L	Art. N°	
						Art. N°	Art. N°
DC...-0702..	LW3	12x12	6	6	20	LW3-SDJCL-12-0620-07-JET	LW3-SDJCR-12-0620-07-JET
	LW4	16x16	8	8	25	LW4-SDJCL-16-0825-07-JET	LW4-SDJCR-16-0825-07-JET
DC...-11T3..	LW3	12x12	6	6	25	LW3-SDJCL-12-0625-11-JET	LW3-SDJCR-12-0625-11-JET
	LW4	16x16	8	8	25	LW4-SDJCL-16-0825-11-JET	LW4-SDJCR-16-0825-11-JET

Pièces de rechange Ersatzteile Spare parts	Plaquettes WSP Inserts	LW	Art. N°			
			Art. N°	Art. N°	Art. N°	Art. N°
DC...-0702..	LW3	LW4	V-M2.5X7.8-T8	C-T8	LWX-ER1.007.002	LW3-U00.ER1.000
						LW4-U00.ER1.000
	LW3	LW4	V-M4X9-T15-ISO	C-T15		LW3-U00.ER1.000
						LW4-U00.ER1.000

Têtes interchangeables

Wechselköpfe



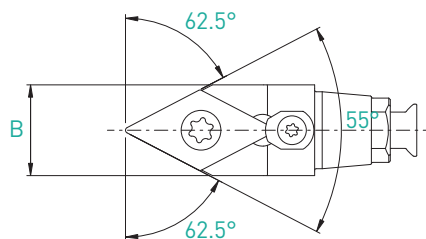
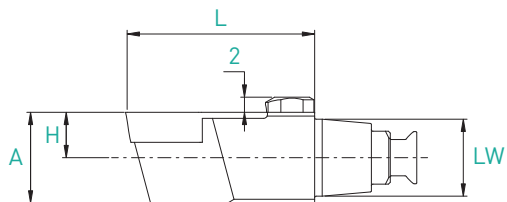
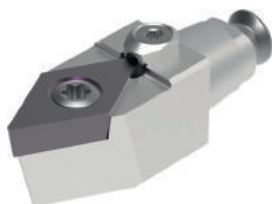

Interchangeable heads

ISO-Line 55°

LW-SDN-JET

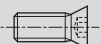

Plaquettes WSP Inserts	LW	A x B	H	L	Art. N°
DC..-0702	LW3	12x12	6	20	LW3-SDNCN-12-0020-07-JET
	LW4	16x16	8	25	LW4-SDNCN-16-0025-07-JET
DC..-11T3	LW3	12x12	6	25	LW3-SDNCN-12-0025-11-JET
	LW4	16x16	8	25	LW4-SDNCN-16-0025-11-JET

Pièces de rechange Ersatzteile Spare parts	Plaquettes WSP Inserts	LW				
			Art. N°	Art. N°	Art. N°	Art. N°
DC..-0702	LW3	V-M2.5X7.8-T8	C-T8	LWX-ER1.007.002	LW3-U00.ER1.000	
	LW4				LW4-U00.ER1.000	
DC..-11T3	LW3	V-M4X9-T15-ISO	C-T15	LWX-ER1.007.002	LW3-U00.ER1.000	
	LW4				LW4-U00.ER1.000	

# SWITCH-LINE

Têtes interchangeables  
Wechselköpfe  
Interchangeable heads

ISO-Line 55°

LW-SDH-JET

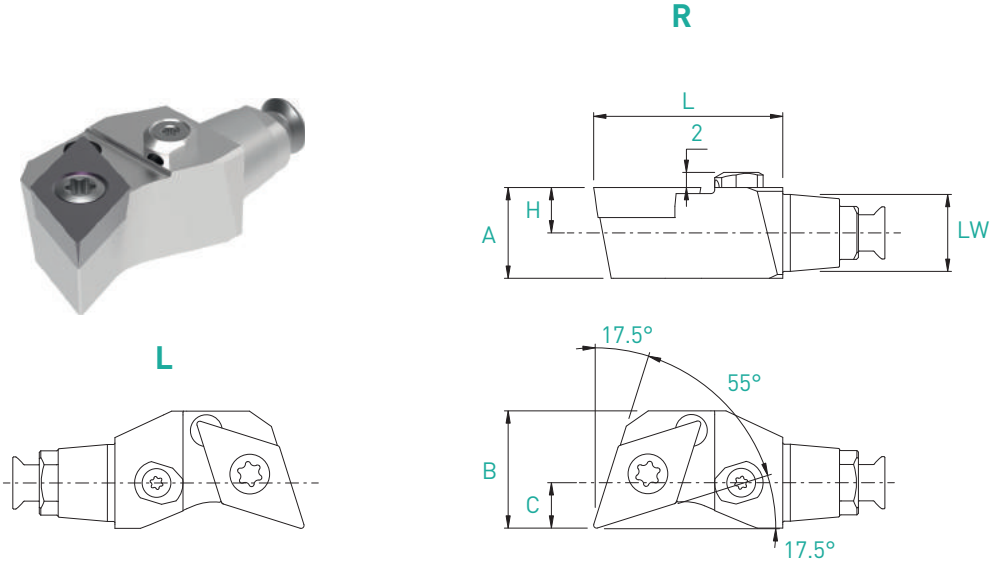

Plaquettes WSP Inserts	LW	A x B	H	C	L	Art. N°	
						Art. N°	Art. N°
DC...-0702..	LW3	12x15.5	6	6	20	LW3-SDHCL-12-0620-07-JET	LW3-SDHCR-12-0620-07-JET
	LW4	16x16	8	8	25	LW4-SDHCL-16-0825-07-JET	LW4-SDHCR-16-0825-07-JET
DC...-11T3..	LW3	12x15.5	6	6	25	LW3-SDHCL-12-0625-11-JET	LW3-SDHCR-12-0625-11-JET
	LW4	16x16	8	8	25	LW4-SDHCL-16-0825-11-JET	LW4-SDHCR-16-0825-11-JET

Pièces de rechange Ersatzteile Spare parts	Plaquettes WSP Inserts	LW	Art. N°	Art. N°	Art. N°	Art. N°
			V-M2.5X7.8-T8	C-T8	LWX-ER1.007.002	LW3-U00.ER1.000 LW4-U00.ER1.000
DC...-0702..	LW3	V-M2.5X7.8-T8	C-T8	LWX-ER1.007.002		LW3-U00.ER1.000
	LW4				LW4-U00.ER1.000	
DC...-11T3..	LW3	V-M4X9-T15-ISO	C-T15	LWX-ER1.007.002	LW3-U00.ER1.000	
	LW4				LW4-U00.ER1.000	

Têtes interchangeables

Wechselköpfe

Interchangeable heads

ISO-Line

35°

LW-SVJ-JET



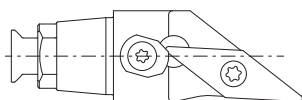

L

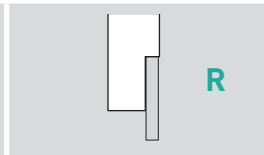
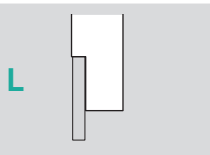
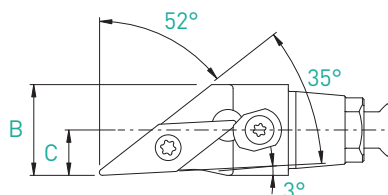
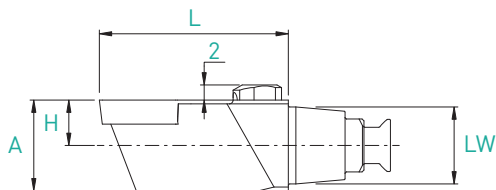

R

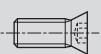
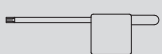

Plaquettes WSP Inserts	LW	A x B	H	C	L	Art. N°	Art. N°
VC...-1103..	LW3	12x12	6	6	25	LW3-SVJCL-12-0625-11-JET	LW3-SVJCR-12-0625-11-JET
	LW4	16x16	8	8	25	LW4-SVJCL-16-0825-11-JET	LW4-SVJCR-16-0825-11-JET
VC...-1303..	LW3	12x12	6	6	30	LW3-SVJCL-12-0630-13-JET	LW3-SVJCR-12-0630-13-JET
	LW4	16x16	8	8	30	LW4-SVJCL-16-0830-13-JET	LW4-SVJCR-16-0830-13-JET
VC...-1604..	LW4	16x16	8	8	35	LW4-SVJCL-16-0835-16-JET	LW4-SVJCR-16-0835-16-JET

Pièces de rechange Ersatzteile Spare parts	Plaquettes WSP Inserts	LW				
			Art. N°	Art. N°	Art. N°	Art. N°
VC...-1103..	LW3	V-M2.5X7.8-T8	C-T8	LWX-ER1.007.002	LW3-U00.ER1.000	
	LW4				LW4-U00.ER1.000	
VC...-1303..	LW3	V-M4X9-T15-ISO	C-T15	LWX-ER1.007.002	LW3-U00.ER1.000	
	LW4				LW4-U00.ER1.000	
VC...-1604..	LW4	V-M4X9-T15-ISO	C-T15	LWX-ER1.007.002	LW4-U00.ER1.000	



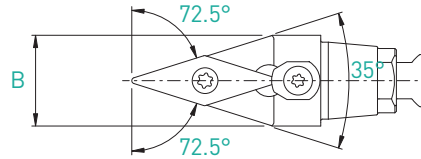
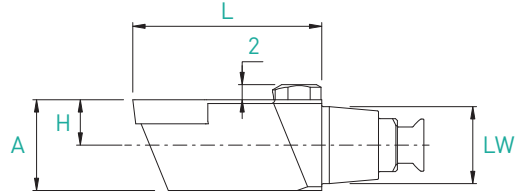
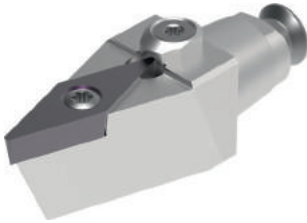

Têtes interchangeables  
 Wechselköpfe  
 Interchangeable heads

ISO-Line 35°

LW-SVV-JET



Plaquettes WSP Inserts	LW	A x B	H	L	Art. N°
VC..-1103..	LW3	12x12	6	25	LW3-SVVCN-12-0025-11-JET
	LW4	16x16	8	25	LW4-SVVCN-16-0025-11-JET
VC..-1303..	LW3	12x12	6	30	LW3-SVVCN-12-0030-13-JET
	LW4	16x16	8	30	LW4-SVVCN-16-0030-13-JET
VC..-1604..	LW4	16x16	8	35	LW4-SVVCN-16-0035-16-JET

Pièces de rechange Ersatzteile Spare parts	Plaquettes WSP Inserts	LW				
			Art. N°	Art. N°	Art. N°	Art. N°
VC..-1103..	LW3	V-M2.5X7.8-T8	C-T8	LWX-ER1.007.002	LW3-U00.ER1.000	
	LW4				LW4-U00.ER1.000	
VC..-1303..	LW3	V-M3X7.3-T8-ISO	C-T8	LWX-ER1.007.002	LW3-U00.ER1.000	
	LW4				LW4-U00.ER1.000	
VC..-1604..	LW4	V-M4X9-T15-ISO	C-T15		LW4-U00.ER1.000	







Supports cylindriques

Zylindrische Halter

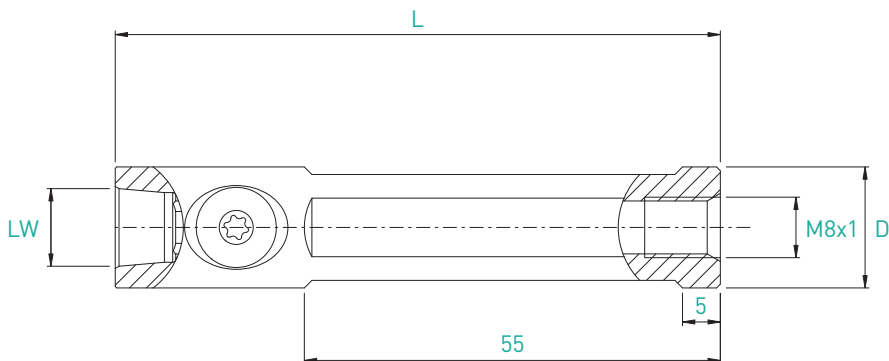
Cylinder holders

LW-D

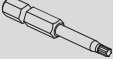

				Pièces rechanges Ersatzteile Spare parts		Options		
								
LW	D	L	L1	Art. N°	Art. N°	Art. N°	Art. N°	
LW3	16	80	55	LW3-D16-80-JET	LW3-ER1.012.014	JB-M8X1	CD-NM3.8	TX15-E6.3
LW4	19.05	80	55	LW4-D19.05-80-JET	LW4-ER1.014.018		CD-NM5.7	TX20-E6.3
	20	80	55	LW4-D20-80-JET	LW4-ER1.014.019			
	22	80	55	LW4-D22-80-JET	LW4-ER1.014.019			
	25	80	55	LW4-D25-80-JET	LW4-ER1.015.023			
	25.4	80	55	LW4-D25.4-80-JET	LW4-ER1.015.023			



Utilisation clé dynamométrique recommandée  
 Benutzung eines Drehmomentschlüssel empfohlen  
 Recommended use of dynamometric key

Options raccords	
	Art. N°
	<b>M8X1</b> voir JET-LINE siehe JET-LINE see JET-LINE

# SWITCH-LINE

Têtes interchangeables porte-pince  
 Spannzangenwechselköpfe  
 Interchangeable heads gripper holder

LW-E

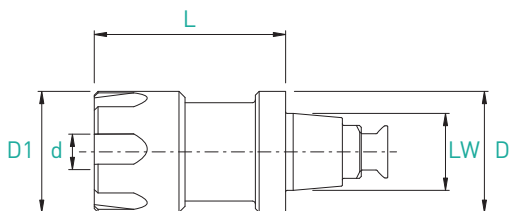

Pièces rechanges  
 Ersatzteile  
 Spare parts



LW	D	D1	L	Pince type	d	Art. N°	Art. N°	Art. N°
LW3	16	16	26	ER11	0.5-7	LW3-E11-D16-26	E11-ER1.001-012	LW3-U00.ER1.00
LW4	19	16	26	ER11	0.5-7	LW4-E11-D19-26		LW4-U00.ER1.00
	19	22	35	ER16	0.5-10	LW4-E16-D19-35	E16-ER1.001-018	

Porte-outils

Halter

Holders

HSK-40-LW3

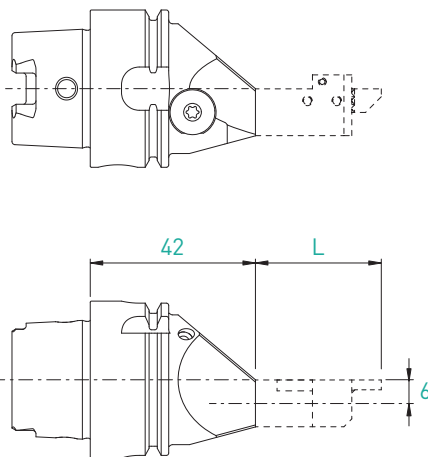

BUMOTEC S191

LW	Compatibility	Page	L	Art. N°	Art. N°
LW3	LW3-740..	11.06	32	HSK-T40-LW3-0642-JET	HSK-A40-LW3-0642-JET-BU**
	LW3-760..	11.07	43		
	LW3-320-340..	11.09/11.11	20		
	LW3-SCLCR..	11.12	20		
	LW3-SCMCN..	11.13	20		
	LW3-SDJCR..	11.14	20		
	LW3-SDNCN..	11.15	20		
	LW3-SDHCR..	11.16	20		
LW3-SVJCR..	11.17	25			

\*\* Pour machines Bumotec

Pièces rechanges Ersatzteile Spare parts	Options	
Art. N°	Art. N°	Art. N°
LW3-ER1.012.014	CD-NM3.8	C-TX15-E6.3



Système d'outils modulaires

Modulares Werkzeugsystem

Modular tooling system

Original system

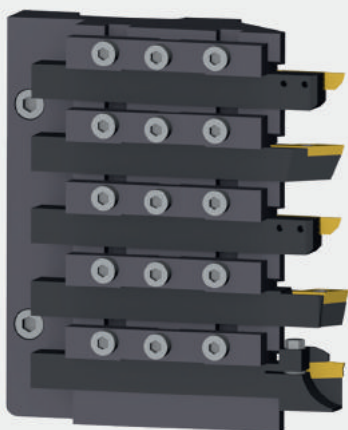

MODU-Line system

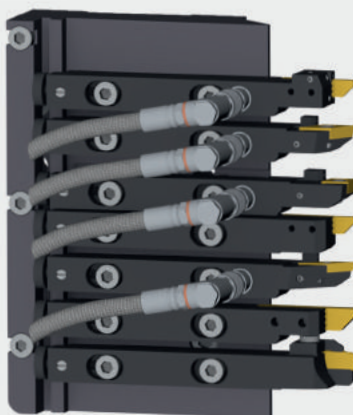

Système d'outils modulaires  
pour tours automatiques

Modulares Werkzeugsystem  
für Langdrehautomaten

Modular tooling system for  
sliding headstock automatic lathes

Les avantages

Die Vorteile

The advantages

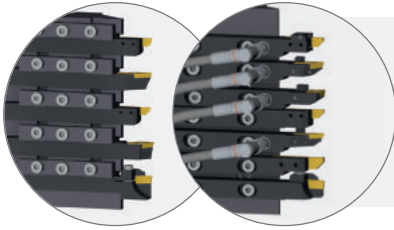

Plus d'outils disponibles  
Höhere Werkzeuganzahl  
More available tools

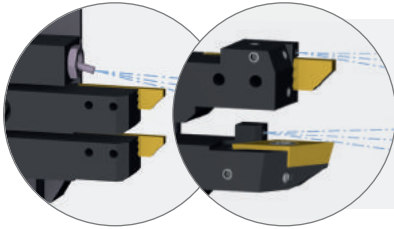

Système d'arrosage efficace  
Effizientes Kühlmittelzufuhrsystem  
Efficient coolant supply system

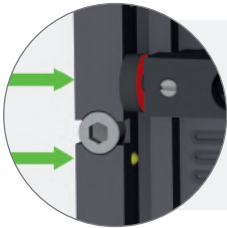

Repositionnement précis, poussée axiale automatique  
Präzise Nachpositionierung, automatischer Axialschub  
Precise repositioning, automatic axial thrust

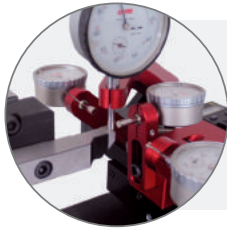

Possibilité de pré réglage et de réglage de la longueur des outils  
Voreinstellbar auf feste oder einstellbare Länge  
Presetting on fixed or adjustable length

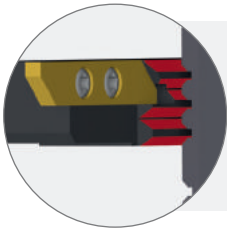

Système de fixation robuste et rigide  
Robustes und starres Spannsystem  
Strong and stable clamping system

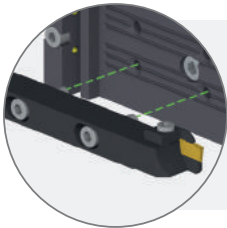

Changement d'outil simple et rapide  
Einfacher und schneller Werkzeugwechsel  
Easy and quick tool replacement

Adaptations disponibles pour les machines suivantes:  
 Verfügbare Anpassungen für folgende Maschinen:  
 Available adapters for the following machines:

**Citizen - Hanwha -  
 Manurhin - Metafil - > 12.06  
 Star - Tornos - Tsugami**

Porte-outils  
 Halter  
 Holders

INFO > 12.60

**ML12**



**ML16**



Right cut

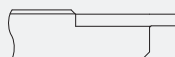

TOP-Line > 12.64

TURN-Line > 12.65

ISO-Line > 12.66

EVOCUT-Line > 12.68

CUT-Line > 12.69

PRO-Line > 12.70

ECO-Line > 12.70

IN-Line > 12.71

TOOLING-Line > 12.73

Cut off line



TOP-Line > 12.74

TURN-Line > 12.76

ISO-Line > 12.77

EVOCUT-Line > 12.78

CUT-Line > 12.79

PRO-Line > 12.80

ECO-Line > 12.81

Modules d'arrosage et de serrage  
 Kühlmittelzufuhr- und Spannelemente  
 Coolant and clamping supply unit

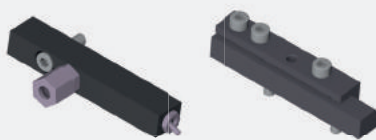

> 12.82

Banc de pré réglage  
 Voreinstellgerät  
 Presetting device

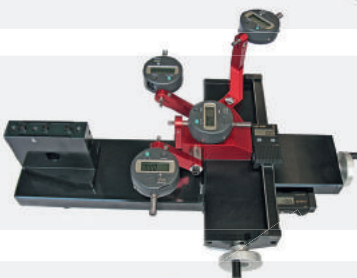

> 12.84

Pièces de rechange  
 Ersatzteile  
 Spare parts





> 12.86

## Adaptations disponibles pour les machines suivantes

## Verfügbare Anpassungen für folgende Maschinen

## Available adapters for the following machines

Fabricant Hersteller Manufacturer	Machine Maschine Machine	Adaptations Anpassungen Adapters	Type Typ Type	Page Seite Page	
Citizen	C12/C16	ML12-CITIZEN-C16	ML12	12.06	
	L12-1M7	ML12-CITIZEN-L12-1M7		12.07	
	L12-2M10	ML12-CITIZEN-L12-2M10		12.08	
	M16V/VIII	ML12-CITIZEN-M16V/VIII		12.09	
	R04			ML12-CITIZEN-R04-QTF3101-3T	12.12
				ML12-CITIZEN-R04-QTF5008-4T	12.10
				ML12-CITIZEN-R04-QTF5108-4T	
	R07			ML12-CITIZEN-R07-QTF4008-5T	12.13
				ML12-CITIZEN-R07-QTF4108-6T	
				ML12-CITIZEN-R07-QTF4208-3T	12.14
				ML12-CITIZEN-R07-QTF4608-4T	
	K12/K16	ML16-CITIZEN-K16		ML16	12.15
L16/L20-5M1/5M7	ML16-CITIZEN-L20	12.16			
L20E-1M8/L20X-1M10/ L20-2M8/2M12	ML16-CITIZEN-L20E		12.17		
Hanwha	XD20M	ML12-HANWHA-XD20M	ML12	12.18	
	SL12/16	ML16-HANWHA-SL12/16	ML16	12.19	
Manuhrin	KMX 426/526/626/ Swingg 20-26 MM	ML16-KMX26-DUO	ML16	12.20	
		ML16-KMX26-JET			
Metafil	D3/D10/D13	ML12-D10-3T	ML12	12.21	
Star	SB-12RG	ML12-STAR-SB-12RG	ML12	12.22	
	SR-10J	ML12-STAR-SR-10J		12.23	
	SW-12RII	ML12-STAR-SW-12RII-2T		12.24	
		ML12-STAR-SW-12RII-8T			
	SA-12/SA-16/SA-16R	ML16-STAR-SA-16	ML16	12.25	
	SB-16	ML16-STAR-SB-16		12.26	
	SB-16/20RG	ML16-STAR-SB-16/20RG		12.27	
	SB-20C/E	ML16-STAR-SB-20		12.28	
	SR-16R/SR-20R/SR-20RII	ML16-STAR-SR-20R		12.29	
	SR-20J/SR-20RIII	ML16-STAR-SR-20J		12.30	
	SR-20JII-A/B	ML16-STAR-SR-20JII-A/B 		12.31	
	SR-20RIV	ML16-STAR-SR-20RIV-2T		12.32	
		ML16-STAR-SR-20RIV-6T			
	SR-32J	ML16-STAR-SR-32J		12.33	
	SV-12/20	ML16-STAR-SV-12/20 		12.35	
	SV-20R	ML16-STAR-SV-20R		12.35	
	SW-20R	ML16-STAR-SW-20R-2T		12.36	
ML16-STAR-SW-20R-6T					



**Adaptations disponibles pour les machines suivantes**
**Verfügbare Anpassungen für folgende Maschinen**
**Available adapters for the following machines**

Fabricant Hersteller Manufacturer	Machine Maschine Machine	Adaptations Anpassungen Adapters	Type Typ Type	Page Seite Page
Tornos	DEC07/10 - EvoDECO 10	ML12-DEC010-DUO	ML12	12.37
		ML12-DEC010-JET		
	SWISS-NANO /SWISS-NANO 7	ML12-SWISS-NANO-2T		12.40
		ML12-SWISS-NANO-3T		
		ML12-SWISS-NANO-6T		
	SWISS-NANO 7	ML12-SWISS-NANO-4T		12.38
	DT13	ML12-DT13-2020206-9T		12.41
	CT20	ML12-CT20-2020019-7T		12.42
	GT13	ML12-GT13-390224-5T		12.43
		ML12-GT13-390223-7T		
	GT26	ML16-GT26-386210-5T		12.44
		ML16-GT26-386209-6T		
	GT32	ML16-GT32-389210-4T		12.46
		ML16-GT32-389209-5T		
	DEC013- EvoDECO16	ML16-DEC013-DUO		12.48
		ML16-DEC013-JET		
DEC020/26 - EvoDECO20/32	ML16-DEC020-DUO	12.50		
	ML16-DEC020-JET			
SIGMA20/32	ML16-S20-DUO	12.51		
	ML16-S20-JET			
SWISS ST26	ML16-SWISS-ST26-DUO	12.52		
	ML16-SWISS-ST26-JET			
DT26	ML16-DT26-2020206-7T	12.53		
Tsugami	B074	ML12-B074-1-6T	ML12	12.54
	B075	ML12-B075-1-8T		12.55
	PO34	ML12-PO34-1-5T		12.56
		ML12-PO34-1-7T		
		ML12-PO34-2-4T		
		ML12-PO34-2-10T		

**Citizen C12 / C16**

+ 2 outils (max 8)  
 + 2 Werkzeuge (max 8)  
 + 2 tools (max 8)

**ML12**

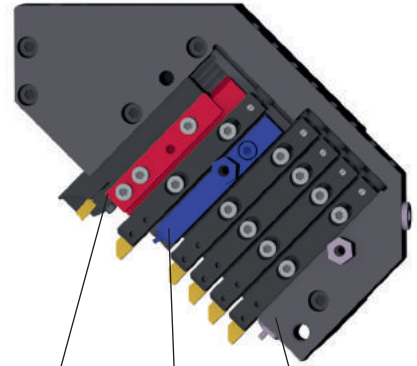
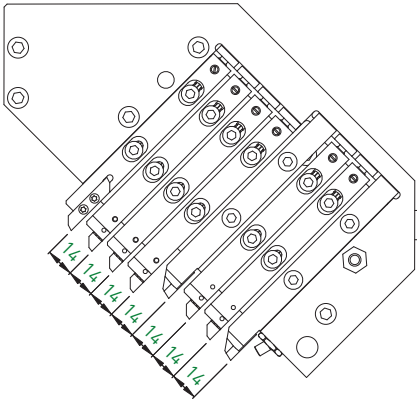

Outil  $\square$  12 mm possible avec module de serrage  
 Werkzeug  $\square$  12 mm mit Spannelement möglich  
 Tool  $\square$  12mm possible with clamping unit

Module d'arrosage (prend la place d'un outil)  
 Kühlmittelzufuhrelement (nimmt den Platz eines Werkzeuges)  
 Coolant supply unit (takes the place of one tool)

Arrosage intégré  
 Integrierter Kühlmittel  
 Integrated coolant

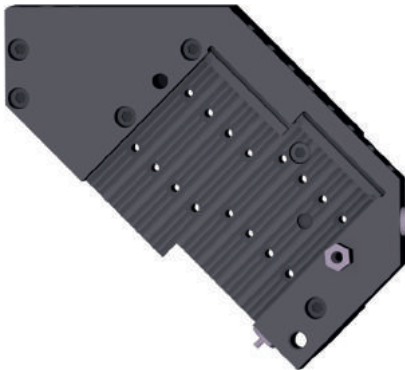

			Accessoires Zubehöre Accessories		
Art. N°	Porte-outils Halter Holders	Pages Seiten Pages	Module de serrage Spannelement Clamping unit	Module d'arrosage Kühlmittelzufuhrelement Coolant supply unit	Page Seite Page
ML12-CITIZEN-C16	ML12	> 12.63	<b>ML12-FIX-12/14</b>	<b>ML12-JET-5/16</b>	12.82

Citizen L12-1M7

- + 2 outils (max 8)
- + 2 Werkzeuge (max 8)
- + 2 tools (max 8)

ML12

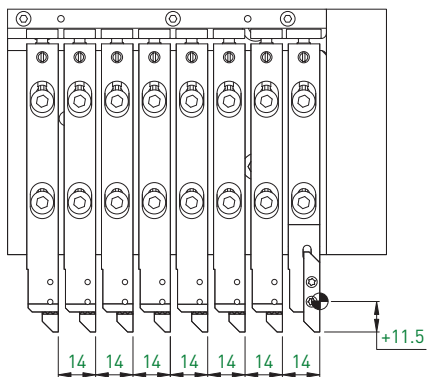

Accessoires  
Zubehöre  
Accessories

Art. N°	Porte-outils Halter Holders	Pages Seiten Pages	Module de serrage Spannelement Clamping unit	Module d'arrosage Kühlmittelzufuhrelement Coolant supply unit	Page Seite Page
ML12-CITIZEN-L12-1M7	ML12	> 12.63	-	<a href="#">ML12-JET-5/16</a>	12.82

**Citizen L12-2M10**

- + 3 outils (max 10)
- + 3 Werkzeuge (max 10)
- + 3 tools (max 10)

**ML12**

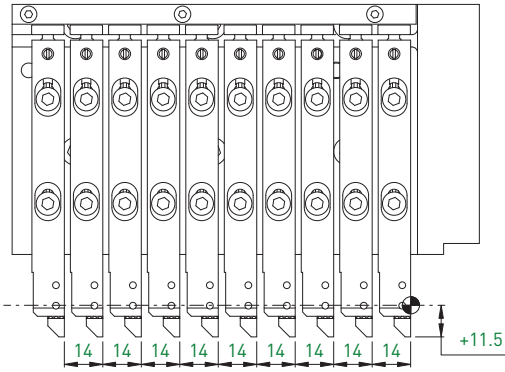

Accessoires  
Zubehöre  
Accessories

Art. N°	Porte-outils Halter Holders	Pages Seiten Pages	Module de serrage Spannelement Clamping unit	Module d'arrosage Kühlmittelzufuhrelement Coolant supply unit	Page Seite Page
ML12-CITIZEN-L12-2M10	ML12	> 12.63	-	<a href="#">ML12-JET-5/16</a>	12.82

Citizen M16 V/VIII

- + 2 outils (max 7)
- + 2 Werkzeuge (max 7)
- + 2 tools (max 7)

ML12

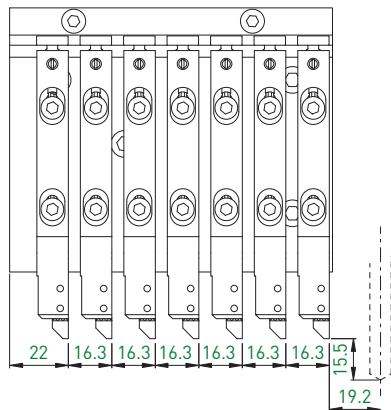

Accessoires  
Zubehöre  
Accessories

Art. N°	Porte-outils Halter Holders	Pages Seiten Pages	Module de serrage Spannelement Clamping unit	Module d'arrosage Kühlmittelzufuhrelement Coolant supply unit	Page Seite Page
ML12-CITIZEN-M16V/VIII	ML12	> 12.63	-	<a href="#">ML12-JET-5/16</a>	12.82

Citizen R04

- + 1 outil (max 8)
- + 1 Werkzeug (max 8)
- + 1 tool (max 8)

ML12

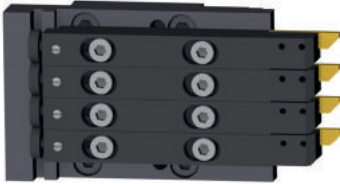
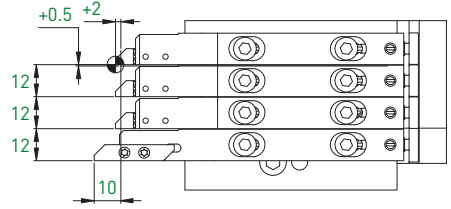
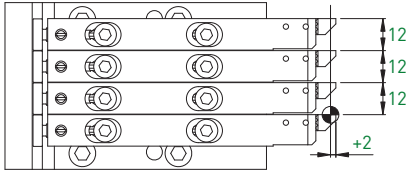

ML12-CITIZEN-R04-QTF5008-4T

ML12-CITIZEN-R04-QTF5108-4T

Type Typ Type	Art. N°	Porte-outils Halter Holders	Pages Seiten Pages	Module de serrage Spannelement Clamping unit	Module d'arrosage Kühlmittelzufuhrelement Coolant supply unit	Page Seite Page
4T	ML12-CITIZEN-R04-QTF5008-4T ML12-CITIZEN-R04-QTF5108-4T	ML12	> 12.63	-	ML12-JET-5/16	12.82

Accessoires  
Zubehöre  
Accessories

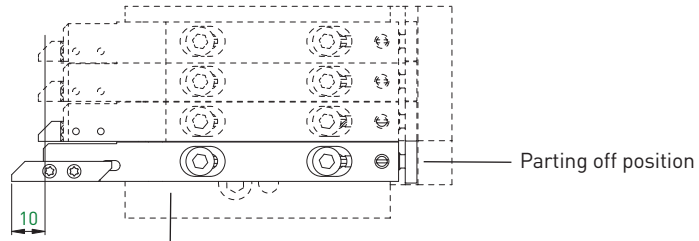

ML12-CITIZEN-R04-QTF5108-4T

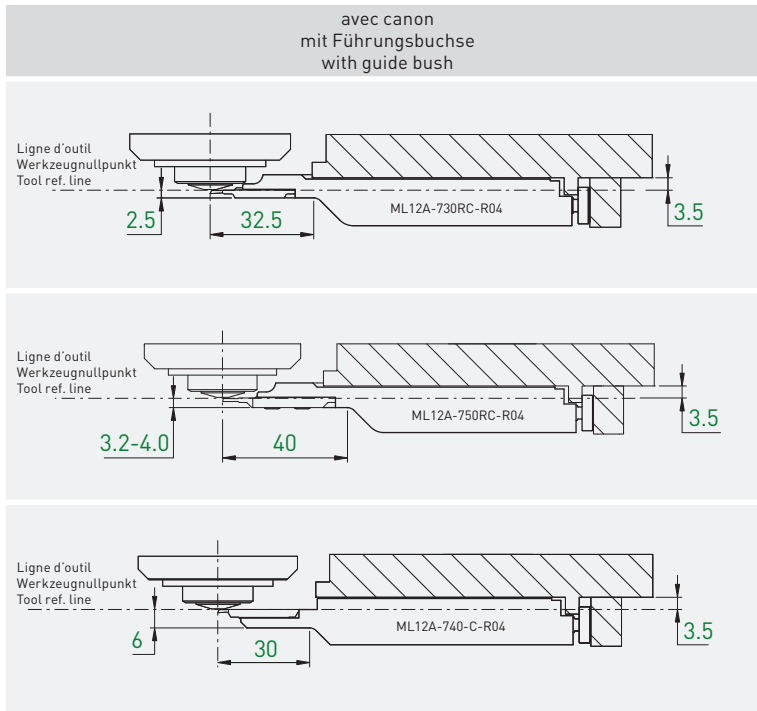

Type de machine Maschinen-Typ Type of machine	Porte-outils Halter Holders	Art. N°	Plaquettes Wendepplatten Inserts	Pages Seiten Pages
Citizen R04	ML12	ML12A-730RC-R04	731R... / 731RSF	> TOP-Line TOP-Watch
		ML12A-750RC-R04	751R... / 751RDSF	
		ML12A-740-C-R04	741 / 741SF	

Citizen R04

- + 3 outils (max 3)
- + 3 Werkzeuge (max 3)
- + 3 tools (max 3)

ML12

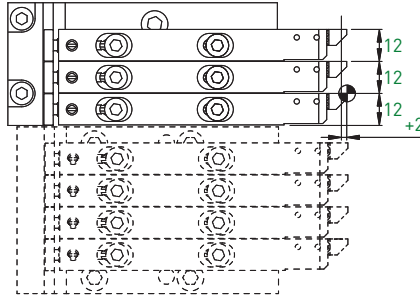

Art. N°	Porte-outils Halter Holders	Pages Seiten Pages	Accessoires Zubehöre Accessories		
			Module de serrage Spannelement Clamping unit	Module d'arrosage Kühlmittelzufuhrelement Coolant supply unit	Page Seite Page
ML12-CITIZEN-R04-QTF3101-3T	ML12	> 12.63	-	<a href="#">ML12-JET-5/16</a>	12.82



Citizen R07

- + 1 outil (max 11)
- + 1 Werkzeug (max 11)
- + 1 tool (max 11)

ML12

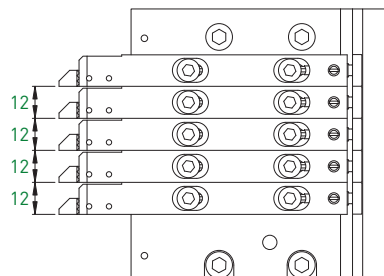
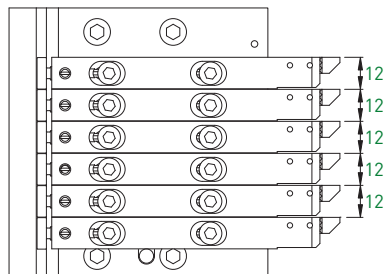

ML12-CITIZEN-R07-QTF4108-6T

ML12-CITIZEN-R07-QTF4008-5T

Type Typ Type	Art. N°	Porte-outils Halter Holders	Pages Seiten Pages	Module de serrage Spannelement Clamping unit	Module d'arrosage Kühlmittelzufuhrelement Coolant supply unit	Page Seite Page
5T	<b>ML12-CITIZEN-R07-QTF4008-5T</b>	ML12	> 12.63	-	<b>ML12-JET-5/16</b>	12.82
6T	<b>ML12-CITIZEN-R07-QTF4108-6T</b>					

Accessoires  
Zubehöre  
Accessories

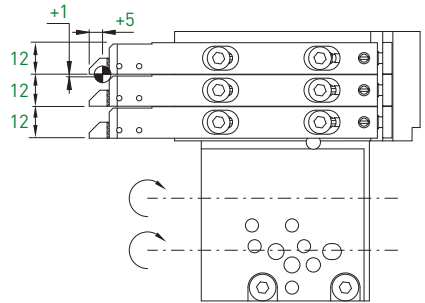
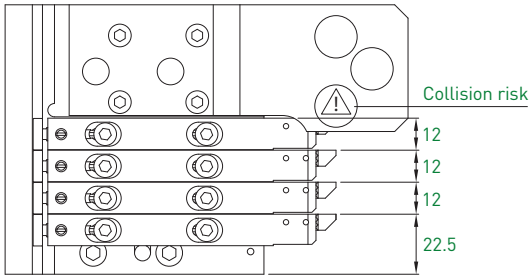

ML12-CITIZEN-R07-QTF4608-4T

ML12-CITIZEN-R07-QTF4208-3T

Type Typ Type	Art. N°	Porte-outils Halter Holders	Pages Seiten Pages	Module de serrage Spannelement Clamping unit	Accessoires Zubehöre Accessories	Page Seite Page
3T	ML12-CITIZEN-R07-QTF4208-3T	ML12	> 12.63	-	Module d'arrosage Kühlmittelzufuhrelement Coolant supply unit	ML12-JET-5/16
4T	ML12-CITIZEN-R07-QTF4608-4T					

Citizen K12 / K16  
K12E / K16E

+ 2 outils (max 8)  
+ 2 Werkzeuge (max 8)  
+ 2 tools (max 8)

ML16

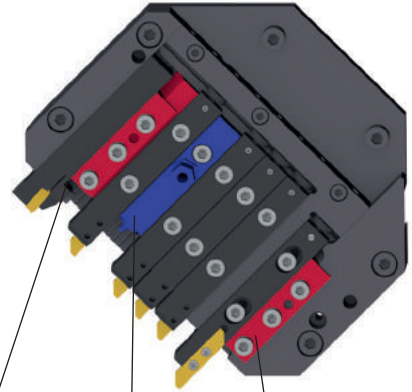
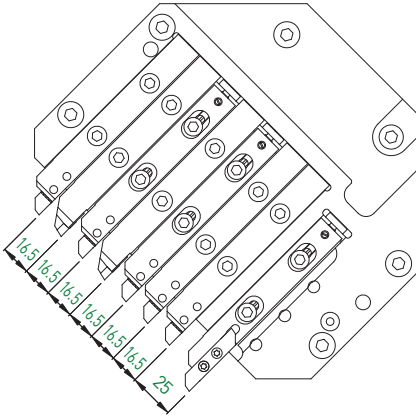

Outil  $\square$  16 mm possible avec module de serrage  
Werkzeug  $\square$  16 mm mit Spannelement möglich  
Tool  $\square$  16 mm possible with clamping unit

Module d'arrosage (prend la place d'un outil)  
Kühlmittelzufuhrelement (nimmt den Platz eines Werkzeuges)  
Coolant supply unit (takes the place of one tool)

1 serrage ML16-FIX-16 pour outil  $\square$  16 mm inclus  
1 Spannung ML16-FIX-16 für Werkzeug  $\square$  16 mm inbegriffen  
1 clamping ML16-FIX-16 for tool  $\square$  16 mm included

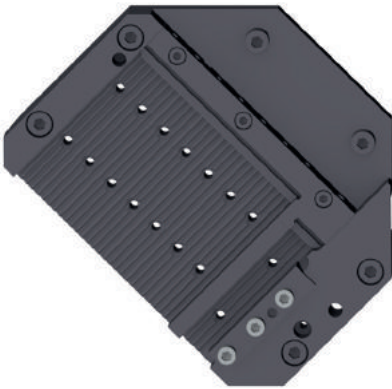

Accessoires  
Zubehöre  
Accessories

Art. N°	Porte-outils Halter Holders	Pages Seiten Pages	Module de serrage Spannelement Clamping unit	Module d'arrosage Kühlmittelzufuhrelement Coolant supply unit	Page Seite Page
ML16-CITIZEN-K16	ML16	> 12.63	<b>ML16-FIX-16/16.5</b>	<b>ML16-JET-7/16</b>	12.82

**Citizen L16 / L20-5M1 / 5M7**

- + 1 outil (max 7)
- + 1 Werkzeug (max 7)
- + 1 tool (max 7)

**ML16**

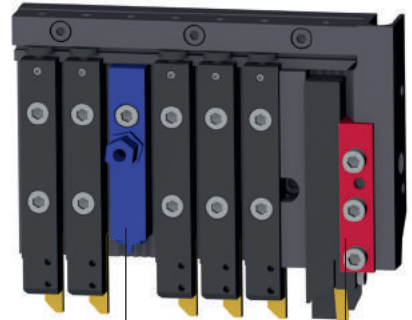
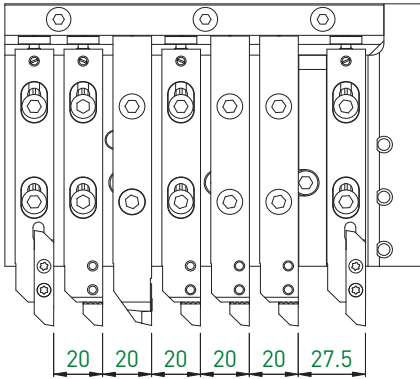

Module d'arrosage (prend la place d'un outil)  
 Kühlmittelzufuhrelement (nimmt den Platz eines Werkzeuges)  
 Coolant supply unit (takes the place of one tool)

- 1 serrage ML16-FIX-16 pour outil  $\varnothing$  16 mm inclus
- 1 Spannung ML16-FIX-16 für Werkzeug  $\varnothing$  16 mm inbegriffen
- 1 clamping ML16-FIX-16 for tool  $\varnothing$  16 mm included



Accessoires  
 Zubehöre  
 Accessories

Art. N°	Porte-outils Halter Holders	Pages Seiten Pages	Module de serrage Spannelement Clamping unit	Module d'arrosage Kühlmittelzufuhrelement Coolant supply unit	Page Seite Page
ML16-CITIZEN-L20	ML16	> 12.63	-	<a href="#">ML16-JET-7/16</a>	12.82

L20E-1M8

+ 1 outil (max 6)

Citizen L20X-1M10

+ 1 Werkzeug (max 6)

ML16

L20-2M8/2M12

+ 1 tool (max 6)

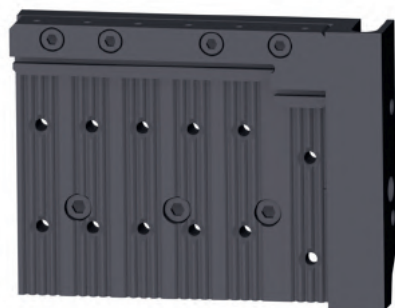
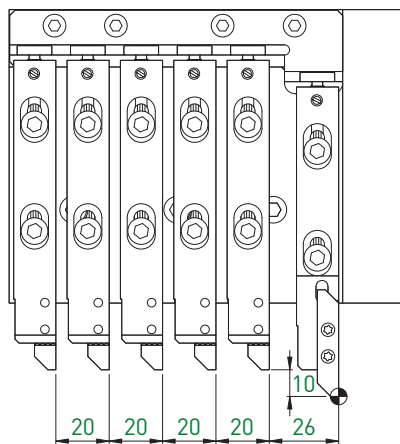

Accessoires  
Zubehöre  
Accessories

Art. N°	Porte-outils Halter Holders	Pages Seiten Pages	Module de serrage Spannelement Clamping unit	Module d'arrosage Kühlmitelzufuhrelement Coolant supply unit	Page Seite Page
ML16-CITIZEN-L20E	ML16	> 12.63	-	ML16-JET-7/16	12.82

**Hanwha XD20M**

- + 2 outils (max 7)
- + 2 Werkzeuge (max 7)
- + 2 tools (max 7)

**ML12**

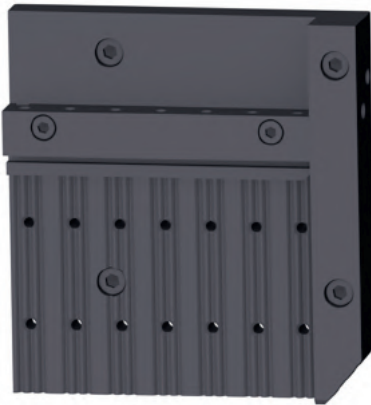
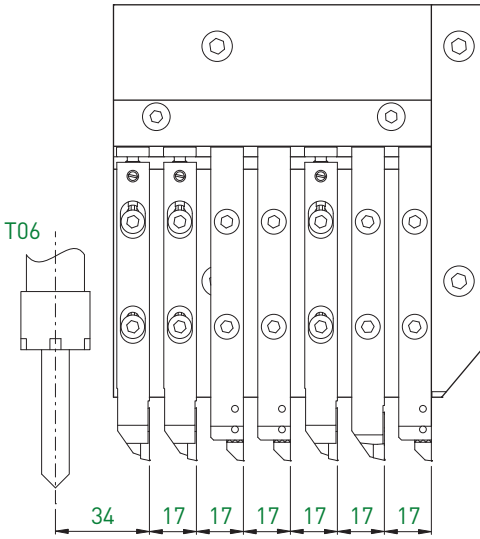

Accessoires  
Zubehöre  
Accessories

Art. N°	Porte-outils Halter Holders	Pages Seiten Pages	Module de serrage Spannelement Clamping unit	Module d'arrosage Kühlmittelzufuhrelement Coolant supply unit	Page Seite Page
ML12-HANWHA-XD20M	ML12	> 12.63	-	<a href="#">ML12-JET-5/16</a>	12.82

Hanwha SL12 / 16

- + 1 outil (max 7)
- + 1 Werkzeug (max 7)
- + 1 tool (max 7)

ML16

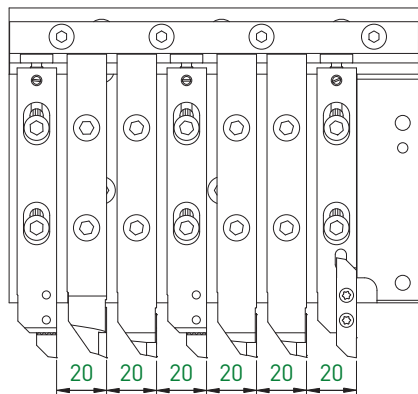

Accessoires  
Zubehöre  
Accessories

Art. N°	Porte-outils Halter Holders	Pages Seiten Pages	Module de serrage Spannelement Clamping unit	Module d'arrosage Kühlmittelzufuhrelement Coolant supply unit	Page Seite Page
ML16-HANWHA-SL12/16	ML16	> 12.63	-	<a href="#">ML16-JET-7/16</a>	12.82

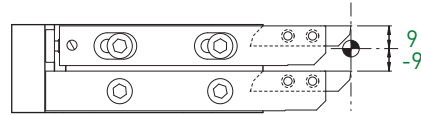
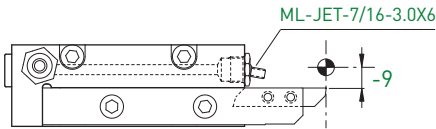
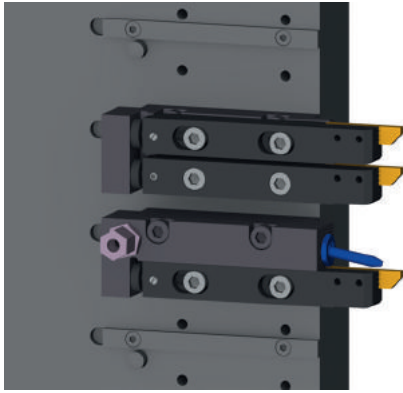

Jet



Duo

Accessoires  
Zubehöre  
Accessories

Type Typ Type	Art. N°	Porte-outils Halter Holders	Pages Seiten Pages	Module de serrage Spannelement Clamping unit	Module d'arrosage Kühlmittelzufuhrelement Coolant supply unit	Page Seite Page
Jet	<b>ML16-KMX26-JET</b>	ML16	> 12.63	-	<a href="#">ML-JET-7/16...</a>	12.82
Duo	<b>ML16-KMX26-DUO</b>				<a href="#">ML16-JET-7/16</a>	



D3	+ 1 outil (max 3)	<b>ML12</b>
Metafil D10	+ 1 Werkzeug (max 3)	
D13	+ 1 tool (max 3)	

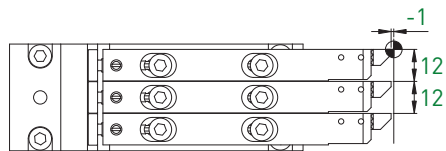

Art. N°	Porte-outils Halter Holders	Pages Seiten Pages	Accessoires Zubehöre Accessories		
			Module de serrage Spannelement Clamping unit	Module d'arrosage Kühlmittelzufuhrelement Coolant supply unit	Page Seite Page
ML12-D10-3T	ML12	> 12.63	-	<a href="#">ML12-JET-5/16</a>	12.82

**Star SB-12RG**

- + 2 outils (max 9)
- + 2 Werkzeuge (max 9)
- + 2 tools (max 9)

**ML12**

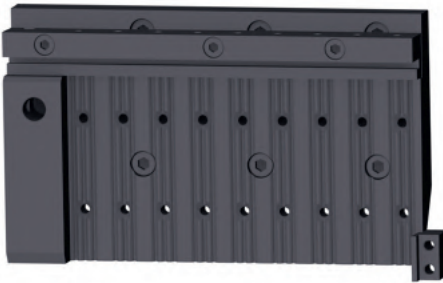
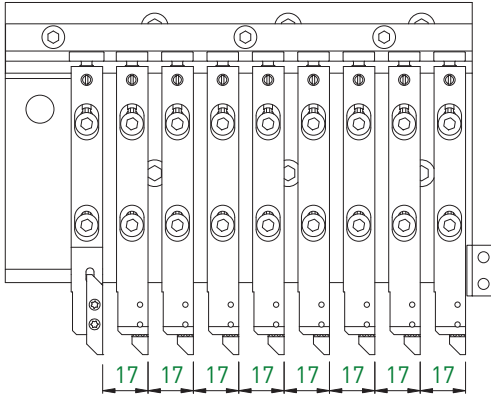

			Accessoires Zubehöre Accessories		
Art. N°	Porte-outils Halter Holders	Pages Seiten Pages	Module de serrage Spannelement Clamping unit	Module d'arrosage Kühlmittelzufuhrelement Coolant supply unit	Page Seite Page
ML12-STAR-SB-12RG	ML12	> 12.63	-	ML12-JET-5/16	12.82

Star SR-10J

- + 2 outils (max 8)
- + 2 Werkzeuge (max 8)
- + 2 tools (max 8)

ML12

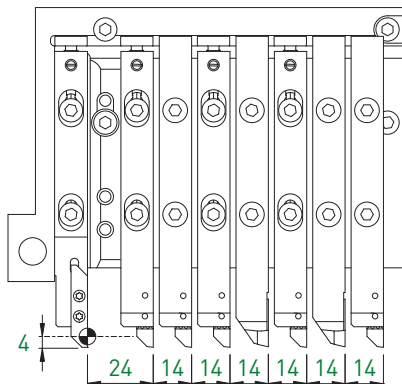

- 1 serrage ML12-FIX-12 pour outil  $\square$  12 mm inclus
- 1 Spannung ML12-FIX-12 für Werkzeug  $\square$  12 mm inbegriffen
- 1 clamping ML12-FIX-12 for tool  $\square$  12 mm included

Module d'arrosage (prend la place d'un outil)  
 Kühlmittelzufuhrelement (nimmt den Platz eines Werkzeuges)  
 Coolant supply unit (takes the place of one tool)



Accessoires  
 Zubehör  
 Accessories

Art. N°	Porte-outils Halter Holders	Pages Seiten Pages	Module de serrage Spannelement Clamping unit	Module d'arrosage Kühlmittelzufuhrelement Coolant supply unit	Page Seite Page
ML12-STAR-SR-10J	ML12	> 12.63	ML12-FIX-12/14	ML12-JET-5/16	12.82

**Star SW-12RII**

+ 2 outils (max 10)  
 + 2 Werkzeuge (max 10)  
 + 2 tools (max 10)

**ML12**

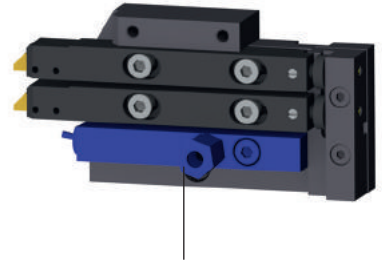
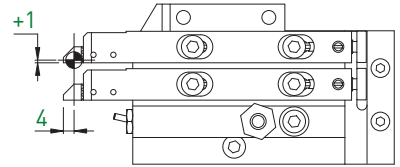
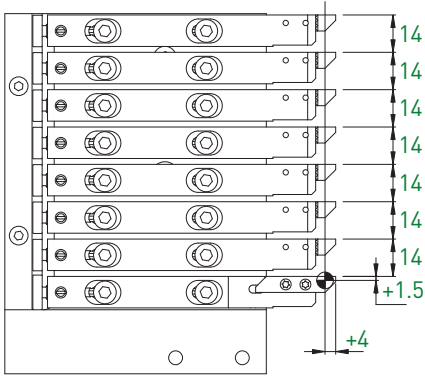

Position uniquement utilisable avec module d'arrosage, en option  
 Position nur mit Kühlmittelzufuhrelement verwendbar, optional  
 Position only with coolant supply unit usable, optional

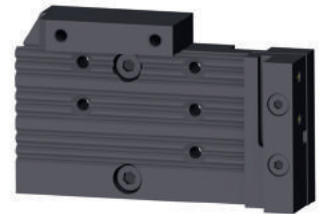

ML12-STAR-SW-12RII-8T

ML12-STAR-SW-12RII-2T

Accessoires  
 Zubehör  
 Accessories

Type Typ Type	Art. N°	Porte-outils Halter Holders	Pages Seiten Pages	Module de serrage Spannelement Clamping unit	Module d'arrosage Kühlmittelzufuhrelement Coolant supply unit	Page Seite Page
2T	<b>ML12-STAR-SW-12RII-2T</b>	ML12	> 12.63	-	<b>ML12-JET-5/16</b>	12.82
8T	<b>ML12-STAR-SW-12RII-8T</b>					

- SA-12 + 2 outils (max 8)
- Star SA-16 + 2 Werkzeuge (max 8)
- SA-16R + 2 tools (max 8)

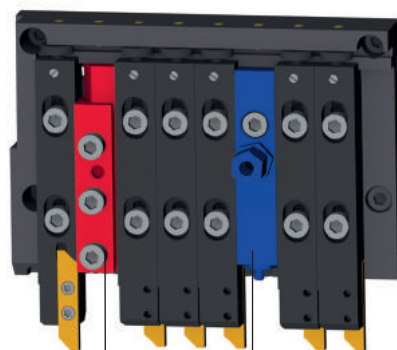
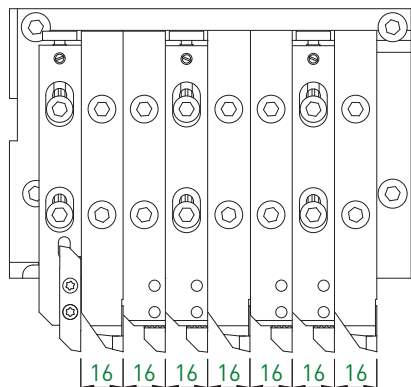

Outil 16 mm possible avec module de serrage  
 Werkzeug 16 mm mit Spannelement möglich  
 Tool 16 mm possible with clamping unit

Module d'arrosage (prend la place d'un outil)  
 Kühlmittelzufuhrelement (nimmt den Platz eines Werkzeuges)  
 Coolant supply unit (takes the place of one tool)



Accessoires  
 Zubehör  
 Accessories

Art. N°	Porte-outils Halter Holders	Pages Seiten Pages	Module de serrage Spannelement Clamping unit	Module d'arrosage Kühlmittelzufuhrelement Coolant supply unit	Page Seite Page
ML16-STAR-SA-16	ML16	> 12.63	ML16-FIX-16/16	ML16-JET-7/16	12.82

**Star SB-16**

- + 3 outils (max 8)
- + 3 Werkzeuge (max 8)
- + 3 tools (max 8)

**ML16**

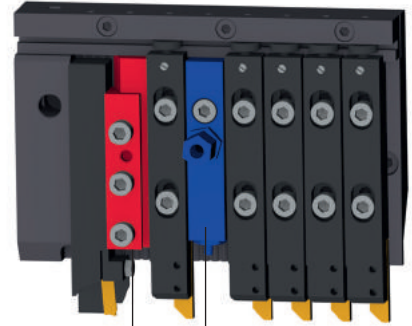
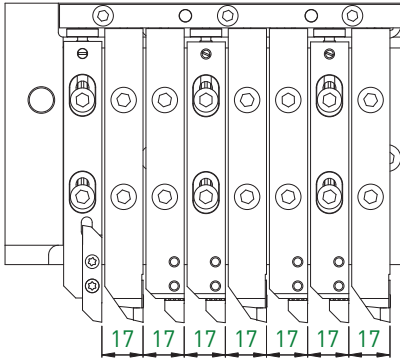

Outil  $\square$  16 mm possible avec module de serrage  
 Werkzeug  $\square$  16 mm mit Spannelement möglich  
 Tool  $\square$  16 mm possible with clamping unit

Module d'arrosage (prend la place d'un outil)  
 Kühlmittelzufuhrelement (nimmt den Platz eines Werkzeuges)  
 Coolant supply unit (takes the place of one tool)



Accessoires  
 Zubehöre  
 Accessories

Art. N°	Porte-outils Halter Holders	Pages Seiten Pages	Module de serrage Spannelement Clamping unit	Module d'arrosage Kühlmittelzufuhrelement Coolant supply unit	Page Seite Page
ML16-STAR-SB-16	ML16	> 12.63	<b>ML16-FIX-16/17</b>	<b>ML16-JET-7/16</b>	12.82

Star SB-16/20RG

- + 1 outil (max 7)
- + 1 Werkzeug (max 7)
- + 1 tool (max 7)

ML16

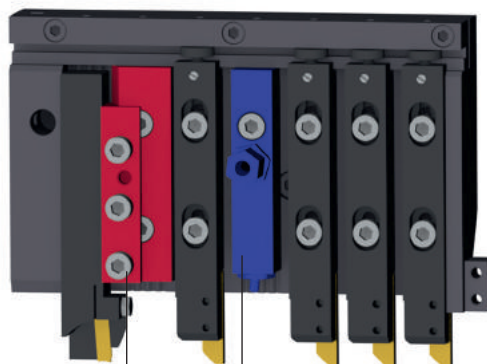
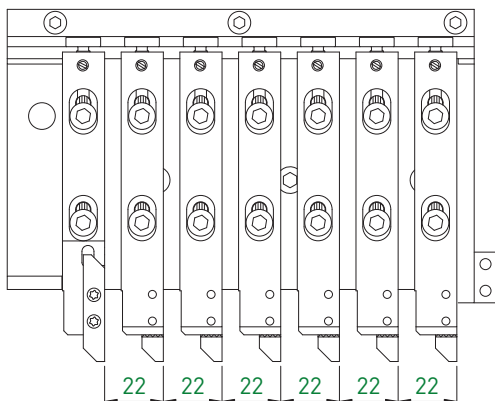

Outil  $\square$  16 mm possible avec module de serrage  
 Werkzeug  $\square$  16 mm mit Spannelement möglich  
 Tool  $\square$  16 mm possible with clamping unit

Module d'arrosage (prend la place d'un outil)  
 Kühlmittelzufuhrelement (nimmt den Platz eines Werkzeuges)  
 Coolant supply unit (takes the place of one tool)



Accessoires  
 Zubehör  
 Accessories

Art. N°	Porte-outils Halter Holders	Pages Seiten Pages	Module de serrage Spannelement Clamping unit	Module d'arrosage Kühlmittelzufuhrelement Coolant supply unit	Page Seite Page
ML16-STAR-SB-16/20RG	ML16	> 12.63	<b>ML16-FIX-16/22</b>	<b>ML16-JET-7/16</b>	12.82

Star SB-20C/E

- + 1 outil (max 7)
- + 1 Werkzeug (max 7)
- + 1 tool (max 7)

ML16

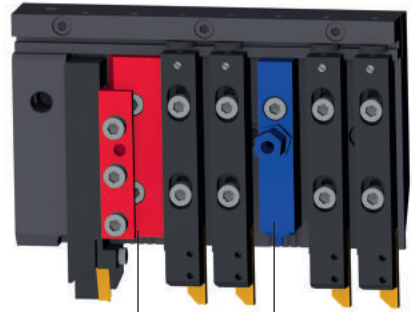
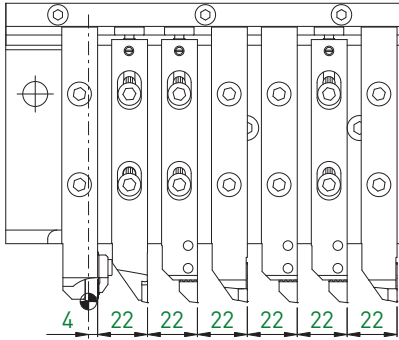

Outil  $\square$  16 mm possible avec module de serrage  
 Werkzeug  $\square$  16 mm mit Spannelement möglich  
 Tool  $\square$  16 mm possible with clamping unit

Module d'arrosage (prend la place d'un outil)  
 Kühlmittelzufuhrelement (nimmt den Platz eines Werkzeuges)  
 Coolant supply unit (takes the place of one tool)



Accessoires  
 Zubehöre  
 Accessories

Art. N°	Porte-outils Halter Holders	Pages Seiten Pages	Module de serrage Spannelement Clamping unit	Module d'arrosage Kühlmittelzufuhrelement Coolant supply unit	Page Seite Page
ML16-STAR-SB20C/E	ML16	> 12.63	ML16-FIX-16/22	ML16-JET-7/16	12.82



- SR-16R** + 3 outils (max 9)
- Star SR-20R** + 3 Werkzeuge (max 9)
- SR-20RII** + 3 tools (max 9)

**ML16**

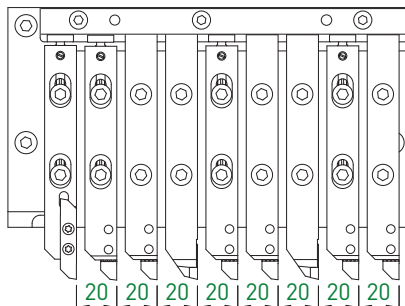

Outil 16 mm possible avec module de serrage  
 Werkzeug 16 mm mit Spannelement möglich  
 Tool 16 mm possible with clamping unit

Module d'arrosage (prend la place d'un outil)  
 Kühlmittelzufuhrelement (nimmt den Platz eines Werkzeuges)  
 Coolant supply unit (takes the place of one tool)



Accessoires  
 Zubehör  
 Accessories

Art. N°	Porte-outils Holder Holders	Pages Seiten Pages	Module de serrage Spannelement Clamping unit	Module d'arrosage Kühlmittelzufuhrelement Coolant supply unit	Page Seite Page
ML16-STAR-SR-20R	ML16	> 12.63	<b>ML16-FIX-16/20</b>	<b>ML16-JET-7/16</b>	12.82

# MODU-LINE

Star **SR-20RIII**  
**SR-20J**

+ 3 outils (max 9)  
+ 3 Werkzeuge (max 9)  
+ 3 tools (max 9)

**ML16**

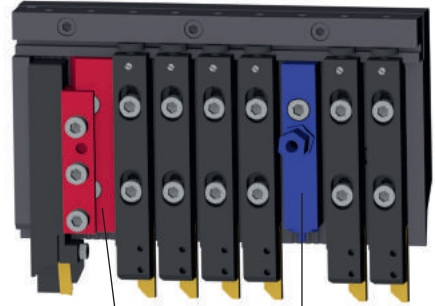
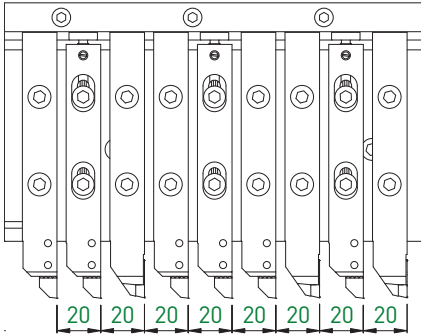

Outil 16 mm possible avec module de serrage  
Werkzeug 16 mm mit Spannelement möglich  
Tool 16 mm possible with clamping unit

Module d'arrosage (prend la place d'un outil)  
Kühlmittelzufuhrelement (nimmt den Platz eines Werkzeuges)  
Coolant supply unit (takes the place of one tool)

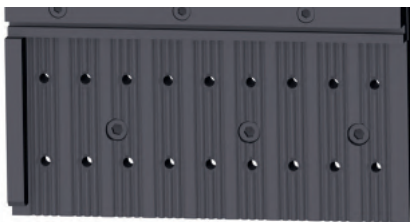

Art. N°	Porte-outils Halter Holders	Pages Seiten Pages	Accessoires Zubehöre Accessories		
			Module de serrage Spannelement Clamping unit	Module d'arrosage Kühlmittelzufuhrelement Coolant supply unit	Page Seite Page
ML16-STAR-SR-20RIII	ML16	> 12.63	<b>ML16-FIX-16/20</b>	<b>ML16-JET-7/16</b>	12.82
ML16-STAR-SR-20J					

Star SR20JII type A/B

- + 3 outils (max 9)
- + 3 Werkzeuge (max 9)
- + 3 tools (max 9)

ML16

**new**

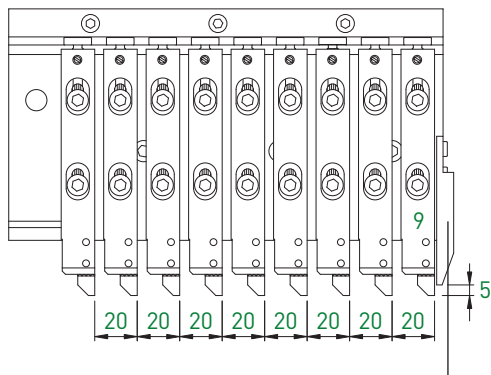

Risque de collision avec outil 9  
 Kollisionsrisiko mit Werkzeug 9  
 Collision risk with tool 9



Accessoires  
 Zubehöre  
 Accessories

Art. N°	Porte-outils Halter Holders	Pages Seiten Pages	Module de serrage Spannelement Clamping unit	Module d'arrosage Kühlmittelzufuhrelement Coolant supply unit	Page Seite Page
ML16-STAR-SR20JII-A/B	ML16	> 12.63	<b>ML16-FIX-16/20</b>	<b>ML16-JET-7/16</b>	12.82

**Star SR-20RIV**

- + 1 outil (max 8)
- + 1 Werkzeug (max 8)
- + 1 tool (max 8)

**ML16**

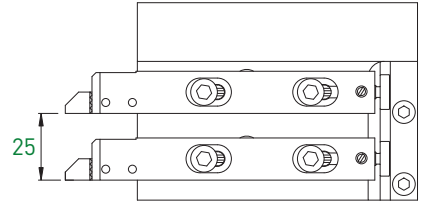
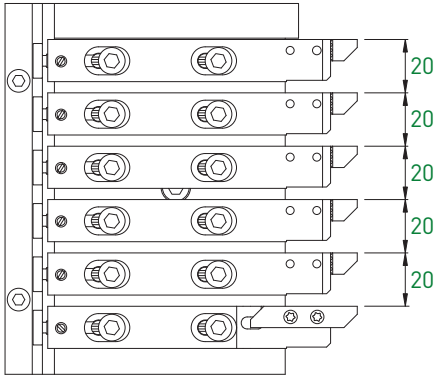

ML16-STAR-SR-20RIV-6T

ML16-STAR-SR-20RIV-2T

Type Typ Type	Art. N°	Porte-outils Halter Holders	Pages Seiten Pages	Module de serrage Spannelement Clamping unit	Accessoires Zubehöre Accessories	Page Seite Page
2T	<b>ML16-STAR-SR-20RIV-2T</b>	ML16	> 12.63	-	Module d'arrosage Kühlmittelezufuhrelement Coolant supply unit	<b>ML16-JET-7/16</b>
6T	<b>ML16-STAR-SR-20RIV-6T</b>					

**Star SR-32J**     $\varnothing$  max 32 mm    + 1 outil (max 7)  
 + 1 Werkzeug (max 7)  
 + 1 tool (max 7)

$\varnothing$  max 16 mm    + 7 outils (max 13)  
 + 7 Werkzeuge (max 13)    **ML16**  
 + 7 tools (max 13)

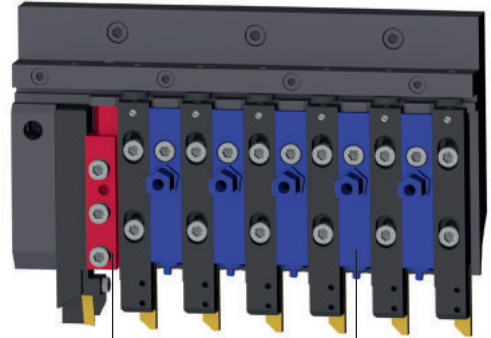
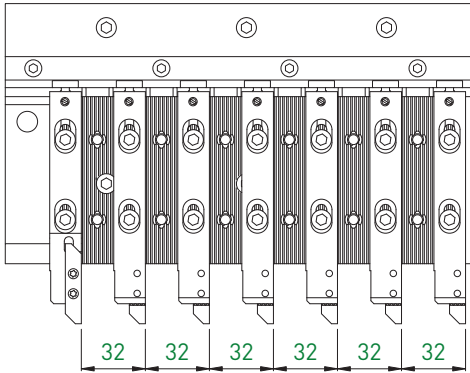

Outil  $\varnothing$  16 mm possible avec module de serrage  
 Werkzeug  $\varnothing$  16 mm mit Spannelement möglich  
 Tool  $\varnothing$  16 mm possible with clamping unit

Module d'arrosage (prend la place d'un outil)  
 Kühlmittelzufuhrelement (nimmt den Platz eines Werkzeuges)  
 Coolant supply unit (takes the place of one tool)

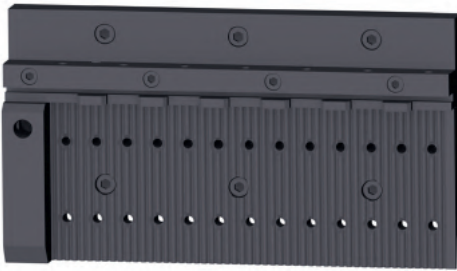

			Accessoires Zubehöre Accessories		
Art. N°	Porte-outils Halter Holders	Pages Seiten Pages	Module de serrage Spannelement Clamping unit	Module d'arrosage Kühlmittelzufuhrelement Coolant supply unit	Page Seite Page
ML16-STAR-SR-32J	ML16	> 12.63	<b>ML16-FIX-16/16</b>	<b>ML16-JET-7/16</b>	12.82

**Star SV-12 / 20**

+ 2 outils (max 7)  
 + 2 Werkzeuge (max 7)  
 + 2 tools (max 7)

**ML16**

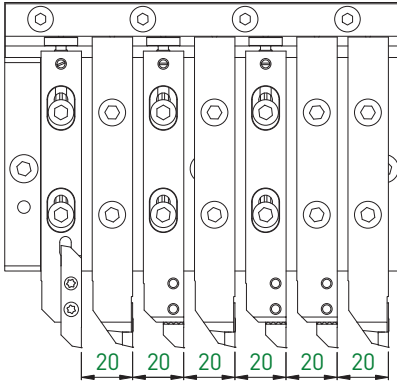

Outil  $\nabla$  16 mm possible avec module de serrage  
 Werkzeug  $\nabla$  16 mm mit Spannelement möglich  
 Tool  $\nabla$  16 mm possible with clamping unit

Module d'arrosage (prend la place d'un outil)  
 Kühlmittelzufuhrelement (nimmt den Platz eines Werkzeuges)  
 Coolant supply unit (takes the place of one tool)



Accessoires  
 Zubehöre  
 Accessories

Art. N°	Porte-outils Halter Holders	Pages Seiten Pages	Module de serrage Spannelement Clamping unit	Module d'arrosage Kühlmittelzufuhrelement Coolant supply unit	Page Seite Page
ML16-STAR-SV-12/20	ML16	> 12.63	<b>ML16-FIX-16/20</b>	<b>ML16-JET-7/16</b>	12.82

Star SV-20R

- + 2 outils (max 9)
- + 2 Werkzeuge (max 9)
- + 2 tools (max 9)

ML16

**new**

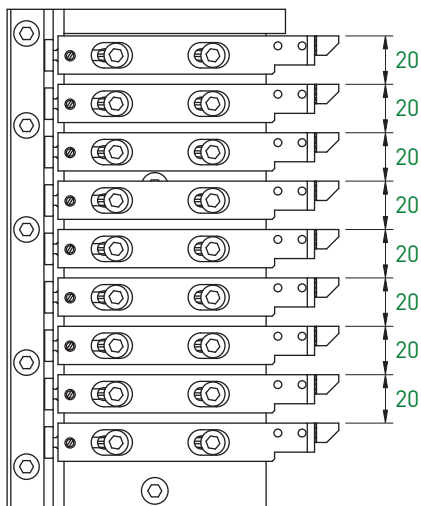

Accessoires  
Zubehöre  
Accessories

Art. N°	Porte-outils Halter Holders	Pages Seiten Pages	Module de serrage Spannelement Clamping unit	Module d'arrosage Kühlmittelzufuhrelement Coolant supply unit	Page Seite Page
ML16-STAR-SV-20R	ML16	> 12.63	<b>ML16-FIX-16/20</b>	<b>ML16-JET-7/16</b>	12.82

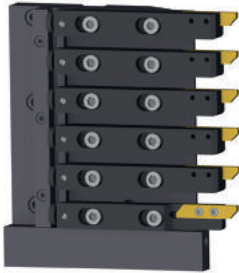
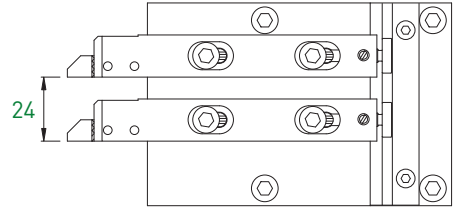
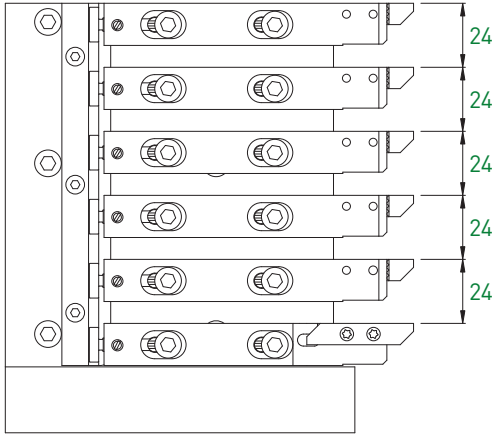

ML16-STAR-SW-20R-6T

ML16-STAR-SW-20R-2T

Accessoires  
 Zubehöre  
 Accessories

Type Typ Type	Art. N°	Porte-outils Halter Holders	Pages Seiten Pages	Module de serrage Spannelement Clamping unit	Module d'arrosage Kühlmittelezufuhrelement Coolant supply unit	Page Seite Page
2T	<b>ML16-STAR-SW-20R-2T</b>	ML16	> 62	-	<b>ML16-JET-7/16</b>	12.82
6T	<b>ML16-STAR-SW-20R-6T</b>			<b>ML16-FIX-16/24</b>		



Jet

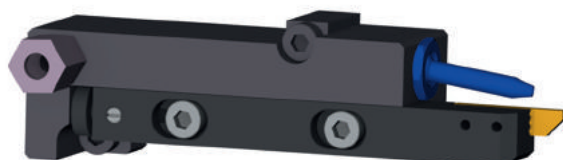

Duo

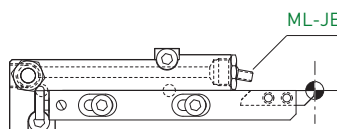
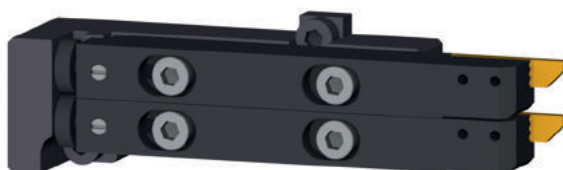

ML-JET-7/16-3.0x6

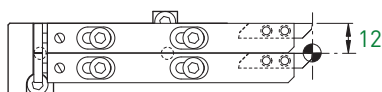

12



Jet



Duo

Accessoires  
Zubehöre  
Accessories

Type Typ Type	Art. N°	Porte-outils Halter Holders	Pages Seiten Pages	Module de serrage Spannelement Clamping unit	Module d'arrosage Kühlmittelezufuhrelement Coolant supply unit	Page Seite Page
Jet	ML12-DEC010-JET	ML12	> 12.63	-	ML-JET-7/16...	12.82
Duo	ML12-DEC010-DUO				ML12-JET-5/16	

**Tornos** SwissNano  
SwissNano 7

+ 2 outils (max 6)  
+ 2 Werkzeuge (max 6)  
+ 2 tools (max 6)

**ML12**

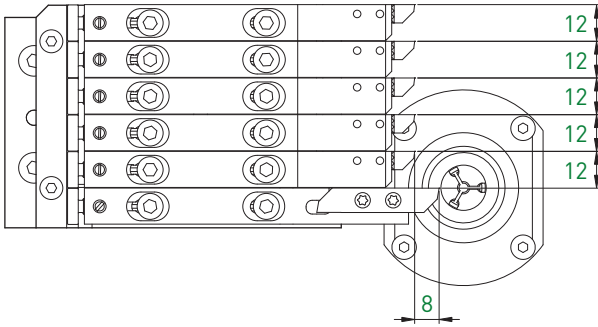

6T



6T

Accessoires  
Zubehöre  
Accessories

Type Typ Type	Art. N°	Porte-outils Halter Holders	Pages Seiten Pages	Module de serrage Spannelement Clamping unit	Module d'arrosage Kühlmittelezufuhrelement Coolant supply unit	Page Seite Page
6T	ML12-SWISS-NANO-6T	ML12	> 12.63	-	<a href="#">ML12-JET-5/16</a>	12.82

**Tornos** SwissNano  
SwissNano 7

**ML12**

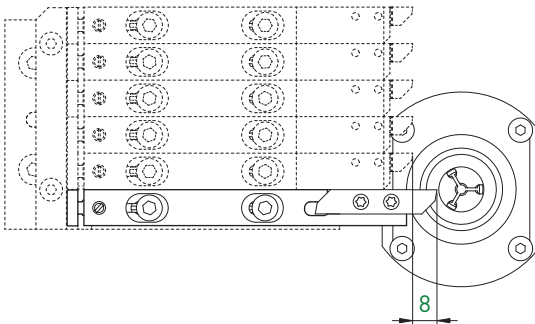

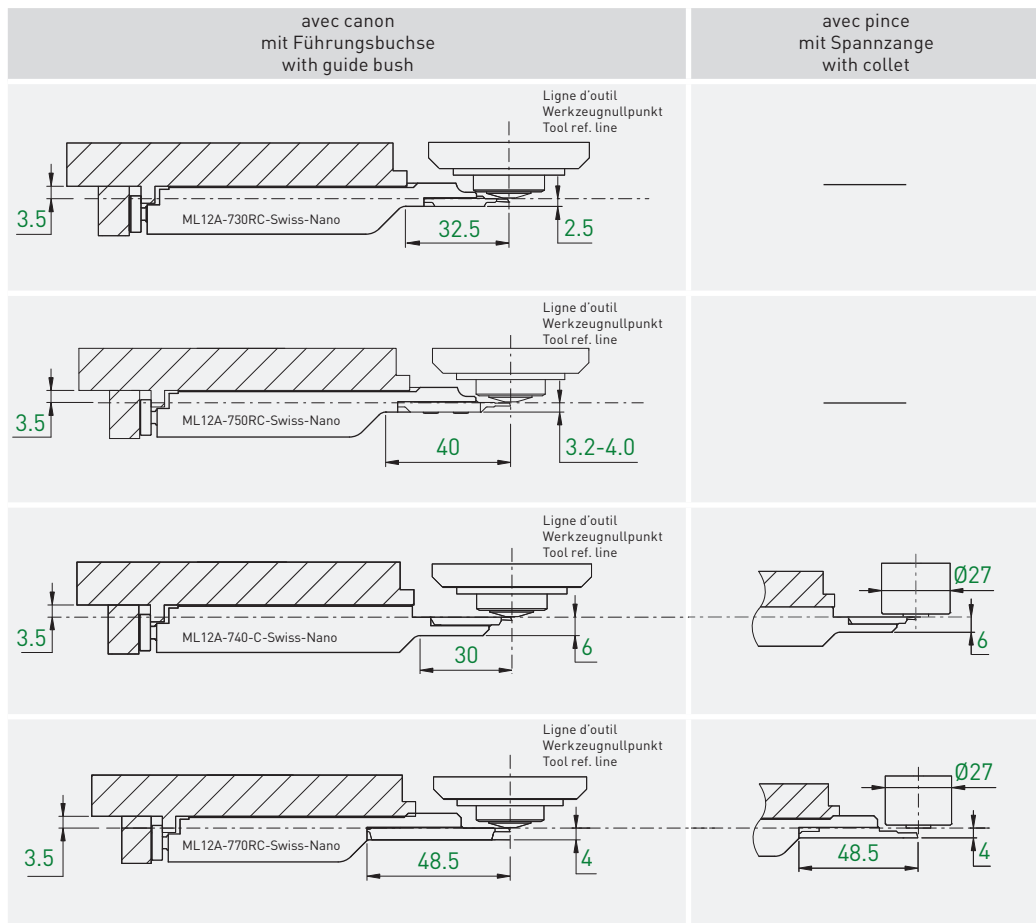

Type de machine Maschinen-Typ Type of machine	Porte-outils Halter Holders	Art. N°	Plaquettes Wendepplatten Inserts	Pages Seiten Pages
SwissNano	ML12	ML12A-730RC-SWISS-NANO	731R... / 731RSF	> TOP-Line TOP-Watch
		ML12A-750RC-SWISS-NANO	751R... / 751RDSF	
		ML12A-740-C-SWISS-NANO	741... / 741SF	> TOP-Line
		ML12A-770RC-SWISS-NANO	771R...	

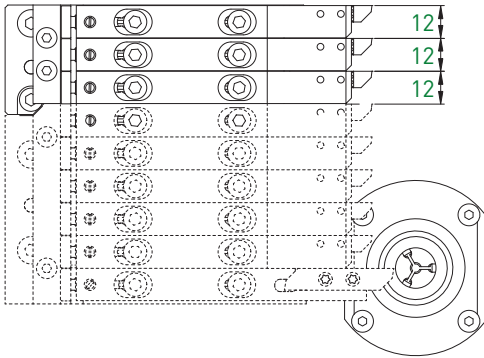
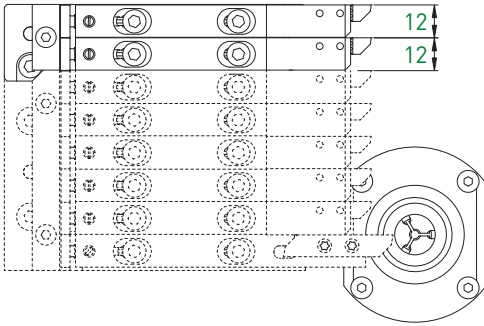

2T



3T

Accessoires  
Zubehöre  
Accessories

Type Typ Type	Art. N°	Porte-outils Halter Holders	Pages Seiten Pages	Module de serrage Spannelement Clamping unit	Module d'arrosage Kühlmittelzufuhrelement Coolant supply unit	Page Seite Page
2T	<b>ML12-SWISS-NANO-2T</b>	ML12	> 12.63	-	<b>ML12-JET-5/16</b>	12.82
3T	<b>ML12-SWISS-NANO-3T</b>					

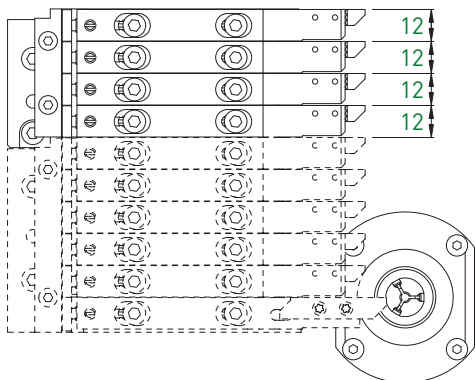

Type Typ Type	Art. N°	Porte-outils Halter Holders	Pages Seiten Pages	Accessoires Zubehöre Accessories		
				Module de serrage Spannelement Clamping unit	Module d'arrosage Kühlmittelelement Coolant supply unit	Page Seite Page
4T	ML12-SWISS-NANO-7-4T	ML12	> 12.63	-	ML12-JET-5/16	12.82

**Tornos DT 13**

+ 3 outils (max 9)  
 + 3 Werkzeuge (max 9)  
 + 3 tools (max 9)

**ML12**

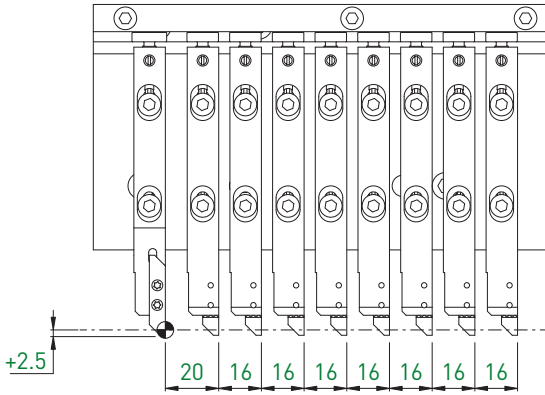

Accessoires  
 Zubehöre  
 Accessories

Type Typ Type	Art. N°	Porte-outils Halter Holders	Pages Seiten Pages	Module de serrage Spannelement Clamping unit	Module d'arrosage Kühlmitelzufuhrelement Coolant supply unit	Page Seite Page
9T	<b>ML12-DT13-2020206-9T</b>	ML12	> 12.63	-	<b>ML12-JET-5/16</b>	12.82

**Tornos CT 20**

- + 1 outil (max 7)
- + 1 Werkzeug (max 7)
- + 1 tool (max 7)

**ML12**

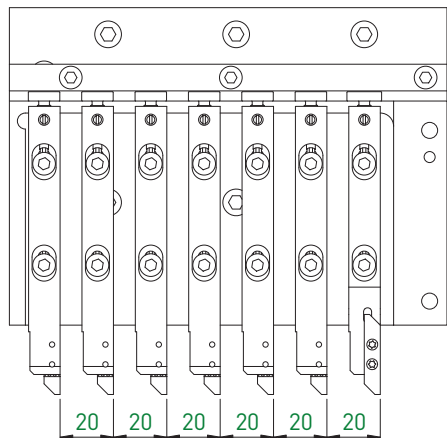

Accessoires  
Zubehöre  
Accessories

Type Typ Type	Art. N°	Porte-outils Halter Holders	Pages Seiten Pages	Module de serrage Spannelement Clamping unit	Module d'arrosage Kühlmitelzufuhrelement Coolant supply unit	Page Seite Page
7T	ML12-CT20-2020019-7T	ML12	> 12.63	-	ML12-JET-5/16	12.82

**Tornos GT 13**

- + 5 outils (max 12)
- + 5 Werkzeuge (max 12)
- + 5 tools (max 12)

**ML12**

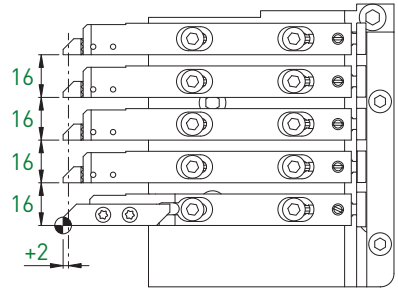
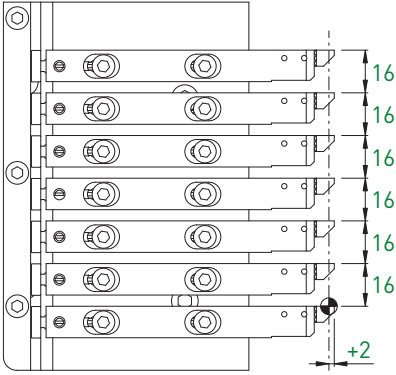





ML12-GT13-390223-7T



ML12-GT13-390224-5T

Type Typ Type	Art. N°	Porte-outils Halter Holders	Pages Seiten Pages	Accessoires Zubehöre Accessories		
				Module de serrage Spannelement Clamping unit	Module d'arrosage Kühlmittelzufuhrelement Coolant supply unit	Page Seite Page
5T	<b>ML12-GT13-390224-5T</b>	ML12	> 12.63	-	<b>ML12-JET-5/16</b>	12.82
7T	<b>ML12-GT13-390223-7T</b>					

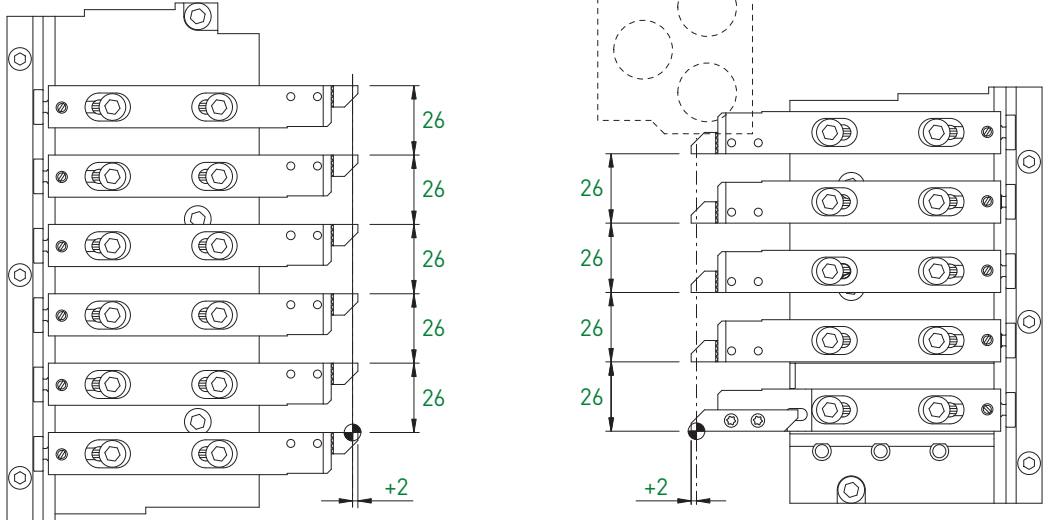

1 serrage ML16-FIX-16 pour outil  $\square$  16 mm inclus  
 1 Spannung ML16-FIX-16 für Werkzeug  $\square$  16 mm inbegriffen  
 1 clamping ML16-FIX-16 for tool  $\square$  16 mm included



ML16-GT26-386209-6T



ML16-GT26-386210-5T

Type Typ Type	Art. N°	Porte-outils Halter Holders	Pages Seiten Pages	Accessoires Zubehöre Accessories		
				Module de serrage Spannelement Clamping unit	Module d'arrosage Kühlmittelezufuhrelement Coolant supply unit	Page Seite Page
5T	<b>ML16-GT26-386210-5T</b>	ML16	> 12.63	-	<b>ML16-JET-7/16</b>	12.82
6T	<b>ML16-GT26-386209-6T</b>					

Tornos GT 32

+ 9 outils  
 max + 9 Werkzeuge  
 + 9 tools

ML16

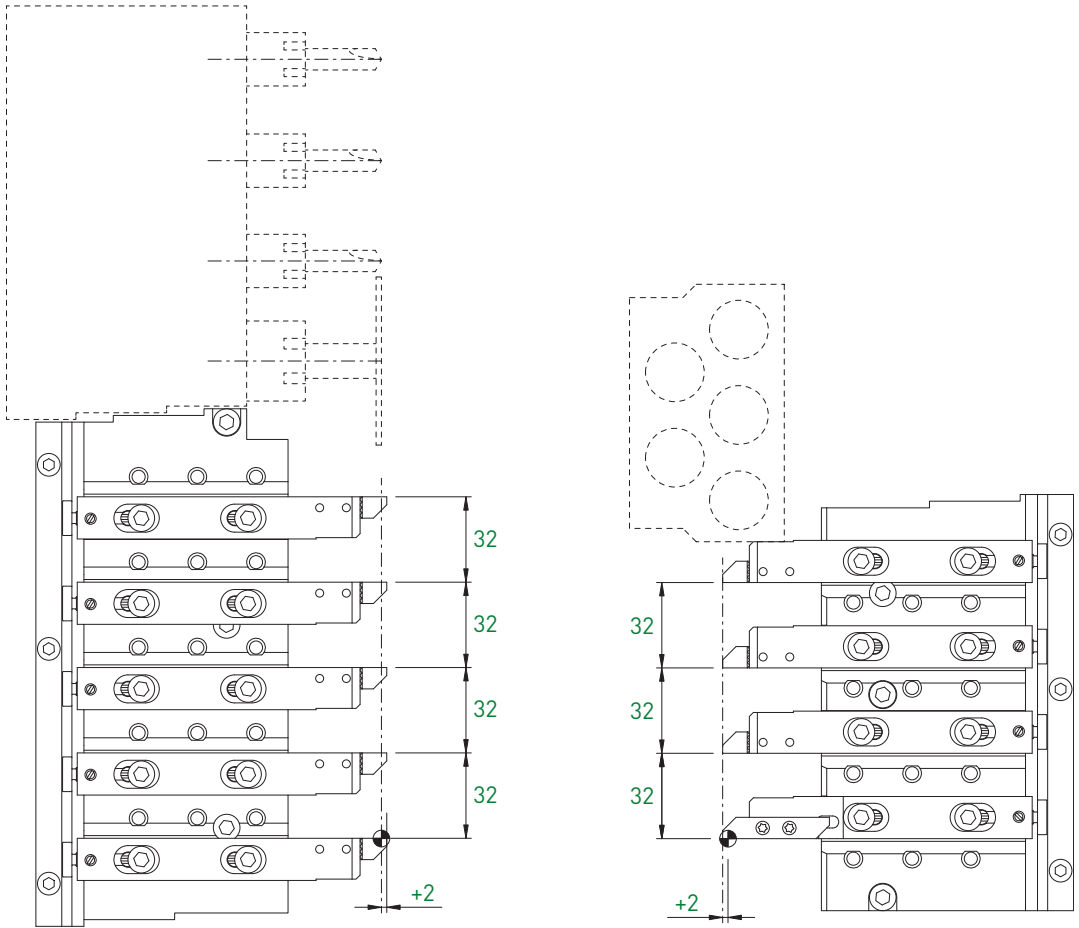

Holder ML16

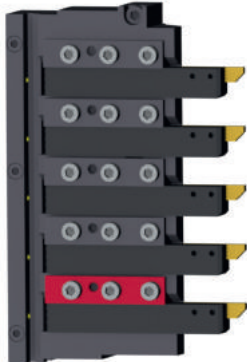

Holder □16



Holder ML16



Holder □16



ML16-GT32-386209-5T



ML16-GT32-386210-4T

				Accessoires Zubehöre Accessories				
Type Typ Type	Art. N°	Porte-outils Halter Holders	Pages Seiten Pages	Module de serrage Spannelement Clamping unit		Module d'arrosage Kühlmittelzufuhrelement Coolant supply unit		Pages Seiten Pages
4T	ML16-GT32-386210-4T	ML16	> 12.63	<b>1x inclus</b> <b>1x inbegriffen</b> <b>1x included</b>		<b>Option</b> <b>ML16-FIX-16</b>	<b>ML16-JET-7/16</b>	12.82
5T	ML16-GT32-386209-5T							

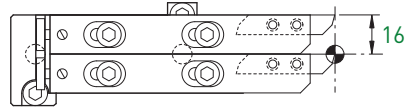
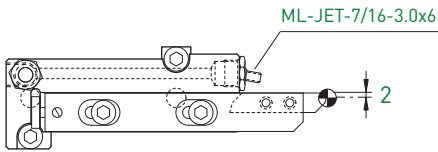

Jet

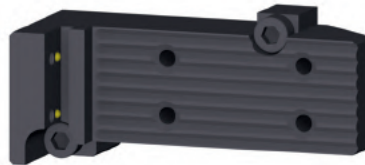

Duo

Accessoires  
Zubehöre  
Accessories

Type Typ Type	Art. N°	Porte-outils Halter Holders	Pages Seiten Pages	Module de serrage Spannelement Clamping unit	Module d'arrosage Kühlmittelezufuhrelement Coolant supply unit	Page Seite Page
Jet	<b>ML16-DEC013-JET</b>	ML16	> 12.63	-	<a href="#">ML-JET-7/16...</a>	12.82
Duo	<b>ML16-DEC013-DUO</b>				<a href="#">ML16-JET-7/16</a>	12.82

Jet



Duo

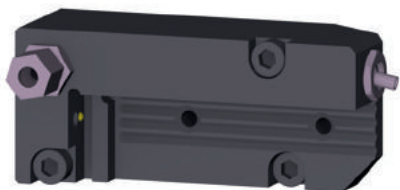
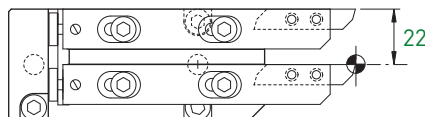
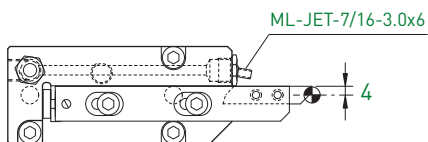

Jet



Duo

Accessoires  
Zubehöre  
Accessories

Type Typ Type	Art. N°	Porte-outils Halter Holders	Pages Seiten Pages	Module de serrage Spannelement Clamping unit	Module d'arrosage Kühlmittelezufuhrelement Coolant supply unit	Page Seite Page
Jet	<b>ML16-DECO20-JET</b>	ML16	> 12.63	-	<a href="#">ML-JET-7/16...</a>	12.82
Duo	<b>ML16-DECO20-DUO</b>				<a href="#">ML16-JET-7/16</a>	12.82

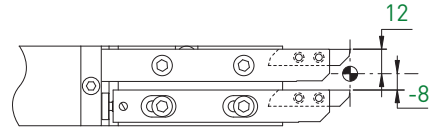
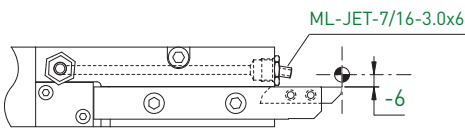
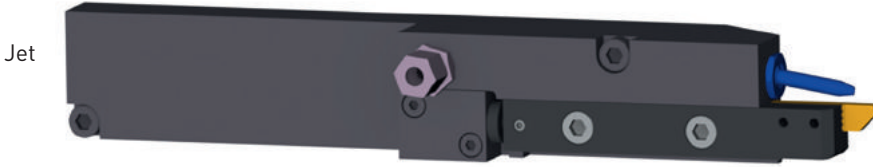

Jet



Duo

Accessoires  
Zubehöre  
Accessories

Type Typ Type	Art. N°	Porte-outils Halter Holders	Pages Seiten Pages	Module de serrage Spannelement Clamping unit	Module d'arrosage Kühlmittelezufuhrelement Coolant supply unit	Page Seite Page
Jet	ML16-S20-JET	ML16	> 12.63	-	ML-JET-7/16...	12.82
Duo	ML16-S20-DUO				ML16-JET-7/16	12.82



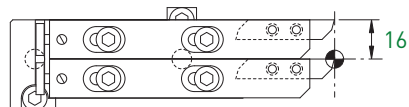
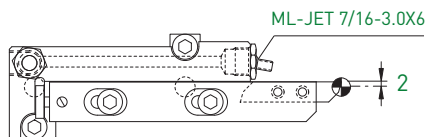
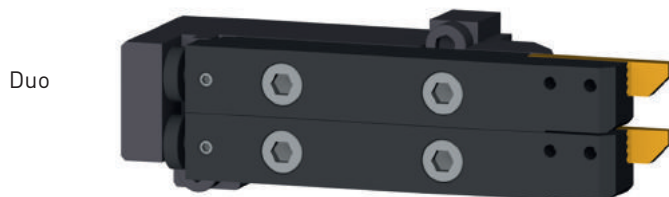

Jet

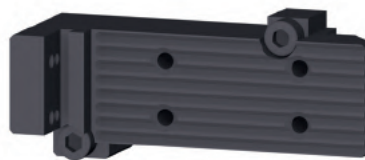

Duo

Type Typ Type	Art. N°	Porte-outils Halter Holders	Pages Seiten Pages	Module de serrage Spannelement Clamping unit	Accessoires Zubehöre Accessories	Page Seite Page
Jet	<b>ML16-SWISS-ST26-JET</b>	ML16	> 12.63	-	Module d'arrosage Kühlmittelezufuhrelement Coolant supply unit	12.82
Duo	<b>ML16-SWISS-ST26-DUO</b>				ML-JET-7/16...	12.82
					ML16-JET-7/16	12.82

**Tornos DT 26**

- + 1 outil (max 7)
- + 1 Werkzeug (max 7)
- + 1 tool (max 7)

**ML16**

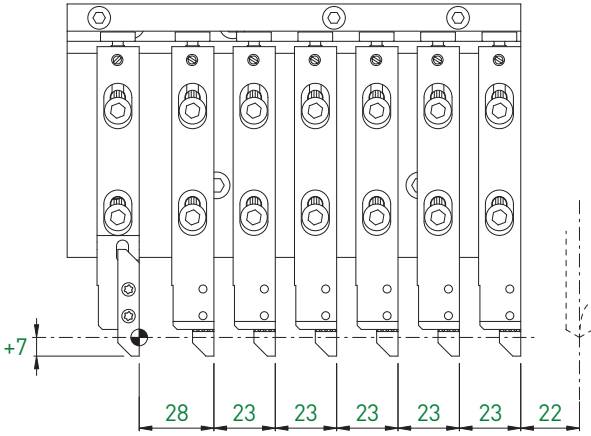

Accessoires  
Zubehöre  
Accessories

Type Typ Type	Art. N°	Porte-outils Halter Holders	Pages Seiten Pages	Module de serrage Spannelement Clamping unit	Module d'arrosage Kühlmittelzufuhrelement Coolant supply unit	Page Seite Page
7T	<b>ML16-DT26-2020206-7T</b>	ML16	> 12.63	-	<b>ML16-JET-7/16</b>	12.82

**Tsugami B074**

- + 3 outils (max 6)
- + 3 Werkzeuge (max 6)
- + 3 tools (max 6)

**ML12**

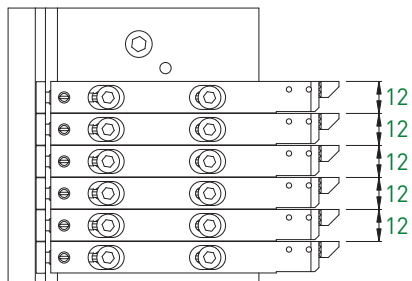

Type Typ Type	Art. N°	Porte-outils Halter Holders	Pages Seiten Pages	Accessoires Zubehöre Accessories		
				Module de serrage Spannelement Clamping unit	Module d'arrosage Kühlmittelzufuhrelement Coolant supply unit	Page Seite Page
6T	<b>ML12-B074-1-6T</b>	ML12	> 12.63	-	<b>ML12-JET-5/16</b>	12.82

**Tsugami B075**

- + 5 outils (max 8)
- + 5 Werkzeuge (max 8)
- + 5 tools (max 8)

**ML12**

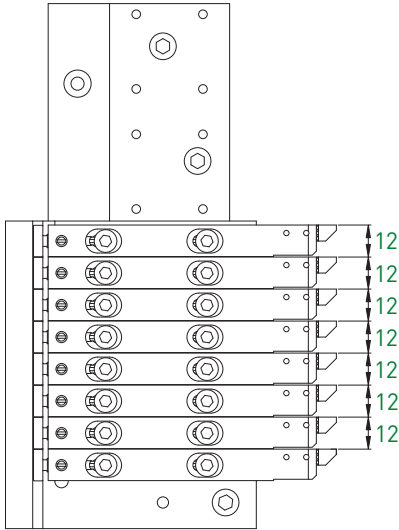

Type Typ Type	Art. N°	Porte-outils Halter Holders	Pages Seiten Pages	Accessoires Zubehöre Accessories		
				Module de serrage Spannelement Clamping unit	Module d'arrosage Kühlmitelzufuhrelement Coolant supply unit	Page Seite Page
8T	<b>ML12-B075-1-8T</b>	ML12	> 12.63	-	<b>ML12-JET-5/16</b>	12.82

Tsugami P034

- + 3 outils (max 9)
- + 3 Werkzeuge (max 9)
- + 3 tools (max 9)

ML12

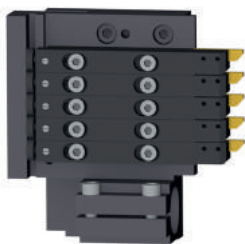
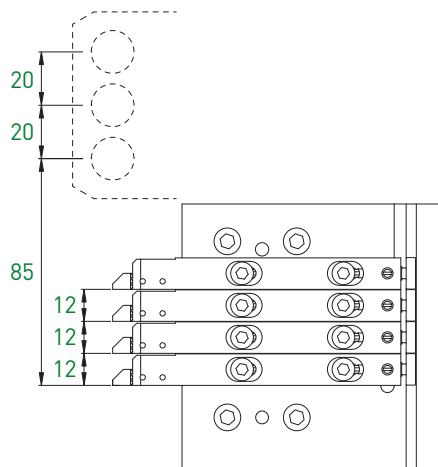
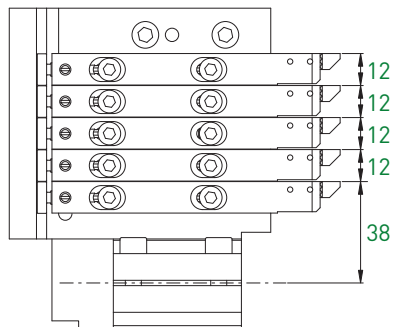

ML12-P034-1-5T

ML12-P034-2-4T

Type Typ Type	Art. N°	Porte-outils Halter Holders	Pages Seiten Pages	Module de serrage Spannelement Clamping unit	Module d'arrosage Kühlmittelzufuhrelement Coolant supply unit	Page Seite Page
4T	ML12-P034-2-4T	ML12	> 12.63	-	ML12-JET-5/16	12.82
5T	ML12-P034-1-5T					

Accessoires  
Zubehöre  
Accessories

Tsugami P034

max + 17 outils  
+ 17 Werkzeuge  
+ 17 tools

## ML12

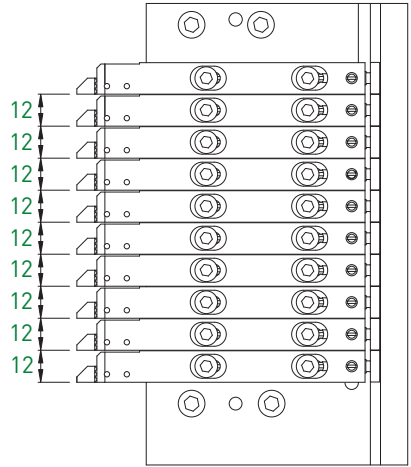
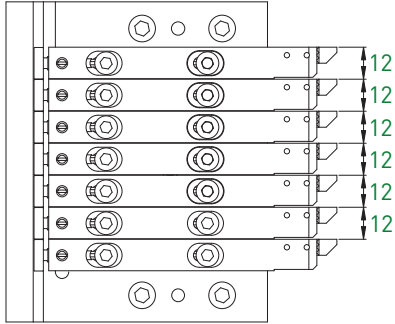

ML12-P034-1-7T

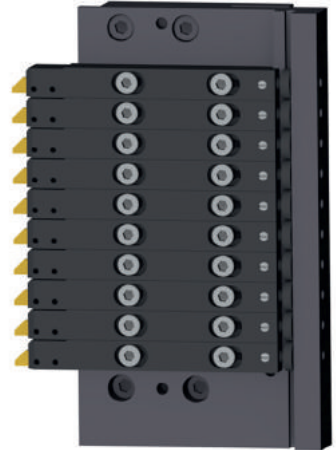

ML12-P034-2-10T



ML12-P034-1-7T



ML12-P034-2-10T

Type Typ Type	Art. N°	Porte-outils Halter Holders	Pages Seiten Pages	Accessoires Zubehöre Accessories		
				Module de serrage Spannelement Clamping unit	Module d'arrosage Kühlmitelzufuhrelement Coolant supply unit	Page Seite Page
7T	<b>ML12-P034-1-7T</b>	ML12	> 12.63	-	<b>ML12-JET-5/16</b>	12.82
10T	<b>ML12-P034-2-10T</b>					

Les différents types de porte-outils  
Die verschiedenen Haltertypen  
The various types of holders

Type Standard

ML12A-740



Type -D

ML12A-740-D



Type -JET-D

ML12A-740-JET-D

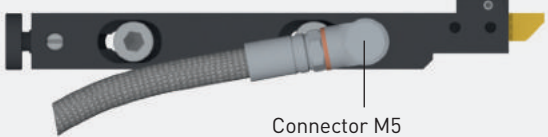

Connector M5

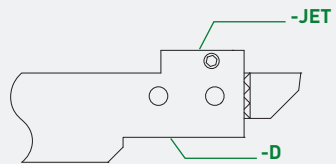

Type -JET

ML12A-740-JET



Connector M5

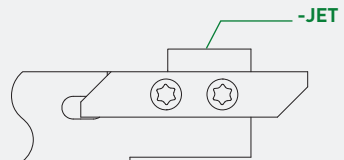



Informations techniques  
 Technische Informationen  
 Technical information

Porte-outils  
 Halter  
 Holders

Compatibilité  
 Kompatibilität  
 Compatibility

OK

NOT OK

-JET-D -D

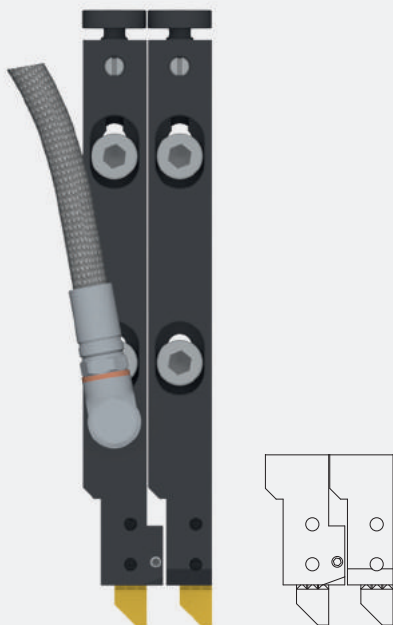

-JET-D -Standard

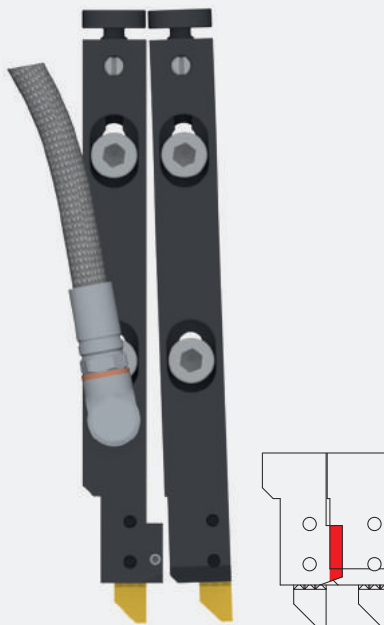

MIX

TYPE D

-Standard -JET-D -D



-JET-D -D -JET-D -D

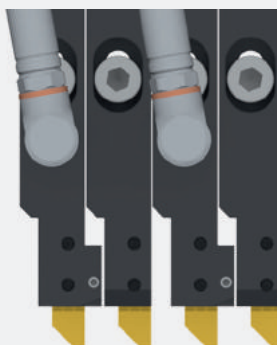

Exceptions  
 Ausnahmen  
 Exceptions

Exception ML12

Exception ML16

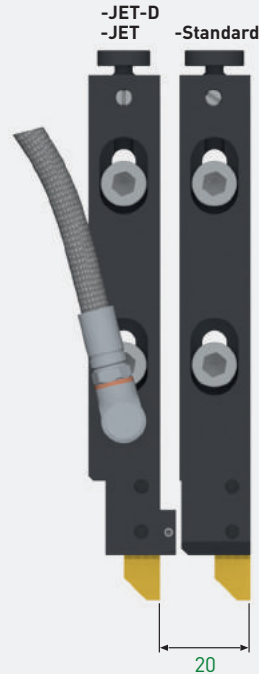
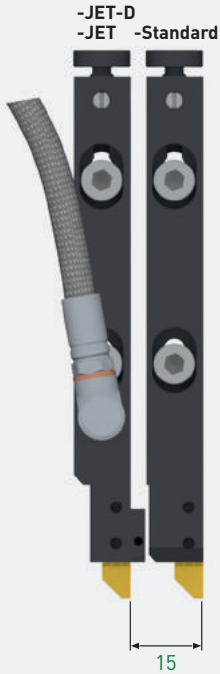

≥ 15 mm = Total compatibility

≥ 20 mm = Total compatibility

**Brochure JET-Line:**

Système de distribution du liquide de refroidissement pour haute pression

**JET-Line Broschüre:**

Kühlmittelverteilungssystem für hohen Druck

**JET-Line brochure:**

Coolant distribution system for high pressure

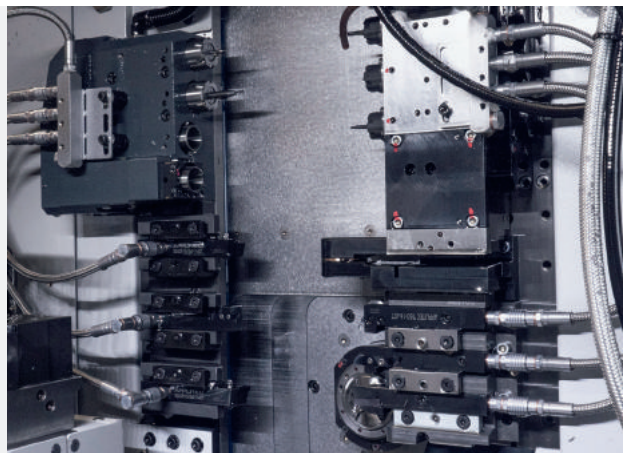

Porte-outils

Halter

Holders

ML12 / ML16

Système de fixation  
Befestigungssystem  
Clamping system

A = réglable  
einstellbar  
adjustable

F = longueur fixe  
fixlänge  
fixed length

ML12A

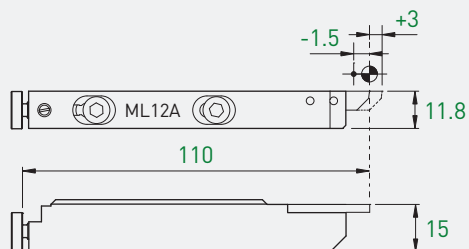

ML12F

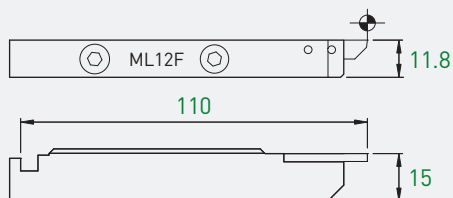

ML16A

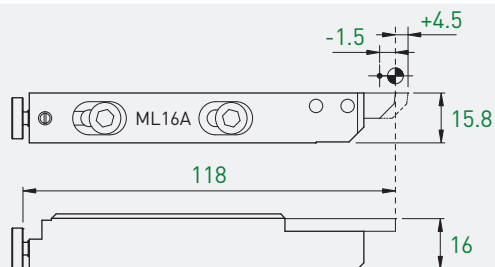

ML16F

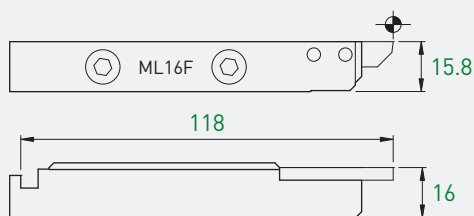

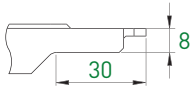

TOP-Line  
731-737

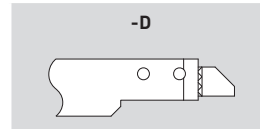

Art. N°	Art. N°	Art. N°
ML12	ML12	ML12
-	ML12A-730-C-D <b>new</b>	-

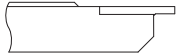

TOP-Line  
741-747

Standard	-D	-JET-D
ML12	ML12	ML12
ML12A-740	ML12A-740-D	ML12A-740-JET-D
ML12F-740	ML12F-740-D	-
ML16	ML16	ML16
ML16A-740	ML16A-740-D	ML16A-740-JET-D
ML16F-740	-	-

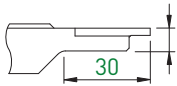

TOP-Line  
741-747

ML12	ML12	ML12
ML12A-740-C	ML12A-740-C-D	ML12A-740-C-JET-D
ML12F-740-C	ML12F-740-C-D	-

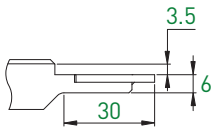

TOP-Line  
741

ML12	ML12	ML12
ML12A-740-C-R04	-	-
ML12A-740-C-SWISS-NANO	-	-

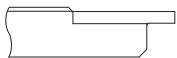

TOP-Line  
761-767

ML12	ML12	ML12
ML12A-760	ML12A-760-D	ML12A-760-JET-D
ML12F-760	ML12F-760-D	-
ML16	ML16	ML16
ML16A-760	ML16A-760-D	ML16A-760-JET-D
ML16F-760	-	-

Porte-plaquettes



WSP-Halter

Insert holders

TOP-Line

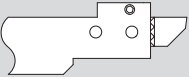

TOP-Line  
761-767

Standard	-D	-JET-D
		
Art. N°	Art. N°	Art. N°
ML16	ML16	ML16
ML16A-760-C	ML16A-760-C-D	-
ML16F-760-C	-	-

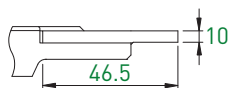

TOP-Line  
781

ML16	ML16	ML16
-	ML16A-780-C-D	-

Porte-plaquettes



WSP-Halter

Insert holders

TURN-Line

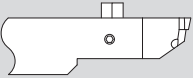

TURN-Line  
347-349

Standard	-D	-JET-D
		
Art. N°	Art. N°	Art. N°
ML12	ML12	ML12
ML12A-340	ML12A-340-D	ML12A-340-JET-D
ML12F-340	ML12F-340-D	-
ML16	ML16	ML16
ML16A-340	ML16A-340-D	ML16A-340-JET-D
ML16F-340	-	-

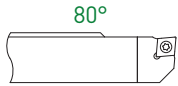

ISO-Line  
CC...-0602..

Standard	-D	-JET-D
Art. N°	Art. N°	Art. N°
<b>ML12</b>	<b>ML12</b>	<b>ML12</b>
ML12A-SCLCR06 ML12F-SCLCR06	ML12A-SCLCR06-D ML12F-SCLCR06-D	ML12A-SCLCR06-JET-D -
<b>ML16</b>	<b>ML16</b>	<b>ML16</b>
ML16A-SCLCR06 ML16F-SCLCR06	ML16A-SCLCR06-D ML16F-SCLCR06-D	ML16A-SCLCR06-JET-D -

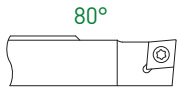

ISO-Line  
CC...-09T3..

<b>ML12</b>	<b>ML12</b>	<b>ML12</b>
ML12A-SCLCR09 ML12F-SCLCR09	ML12A-SCLCR09-D ML12F-SCLCR09-D	ML12A-SCLCR09-JET-D -
<b>ML16</b>	<b>ML16</b>	<b>ML16</b>
ML16A-SCLCR09 ML16F-SCLCR09	ML16A-SCLCR09-D ML16F-SCLCR09-D	ML16A-SCLCR09-JET-D -

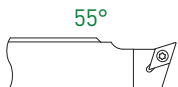

ISO-Line  
DC...-0702..

<b>ML16</b>	<b>ML16</b>	<b>ML16</b>
ML16A-SDHCR07	-	-

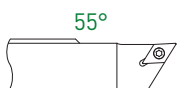

ISO-Line  
DC...-0702..

<b>ML12</b>	<b>ML12</b>	<b>ML12</b>
ML12A-SDJCR07 ML12F-SDJCR07	ML12A-SDJCR07-D ML12F-SDJCR07-D	ML12A-SDJCR07-JET-D -
<b>ML16</b>	<b>ML16</b>	<b>ML16</b>
ML16A-SDJCR07 ML16F-SDJCR07	ML16A-SDJCR07-D ML16F-SDJCR07-D	ML16A-SDJCR07-JET-D -

Porte-plaquettes

WSP-Halter

Insert holders

ISO-Line

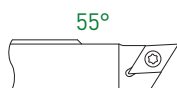

ISO-Line  
DC...-11T3..

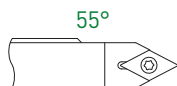

ISO-Line  
DC...-11T3..



ISO-Line  
VC...-1103..

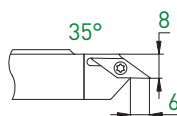

ISO-Line  
VC...-1103..

Standard	-D	-JET-D
Art. N°	Art. N°	Art. N°
ML12	ML12	ML12
ML12A-SDJCR11	ML12A-SDJCR11-D	ML12A-SDJCR11-JET-D
ML12F-SDJCR11	ML12F-SDJCR11-D	-
ML16	ML16	ML16
ML16A-SDJCR11	ML16A-SDJCR11-D	ML16A-SDJCR11-JET-D
ML16F-SDJCR11	ML16F-SDJCR11-D	-

ML12	ML12	ML12
ML12A-SDNCN11	ML12A-SDNCN11-D	-
ML12F-SDNCN11	ML12F-SDNCN11-D	-
ML16	ML16	ML16
ML16A-SDNCN11	ML16A-SDNCN11-D	-
ML16F-SDNCN11	ML16F-SDNCN11-D	-

ML12	ML12	ML12
ML12A-SVJCR11	ML12A-SVJCR11-D	ML12A-SVJCR11-JET-D
ML12F-SVJCR11	ML12F-SVJCR11-D	-
ML16	ML16	ML16
ML16A-SVJCR11	ML16A-SVJCR11-D	ML16A-SVJCR11-JET-D
ML16F-SVJCR11	ML16F-SVJCR11-D	-

ML12	ML12	ML12
ML12A-SV-CR11	ML12A-SV-CR11-D	-
ML16	ML16	ML16
ML16A-SV-CR11	ML16A-SV-CR11-D	-

# MODU-LINE

Porte-plaquettes  
WSP-Halter  
Insert holders

ISO-Line

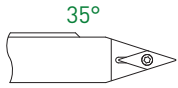

ISO-Line  
VC...-1103..

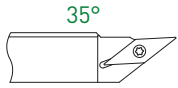

ISO-Line  
VC...-1303..

Standard	-D	-JET-D
Art. N°	Art. N°	Art. N°
<b>ML12</b>	<b>ML12</b>	<b>ML12</b>
<b>ML12A-SVVCN11</b>	<b>ML12A-SVVCN11-D</b>	<b>ML12A-SVVCN11-JET-D</b>
<b>ML12F-SVVCN11</b>	<b>ML12F-SVVCN11-D</b>	-
<b>ML16</b>	<b>ML16</b>	<b>ML16</b>
<b>ML16A-SVVCN11</b>	<b>ML16A-SVVCN11-D</b>	-
<b>ML16F-SVVCN11</b>	<b>ML16F-SVVCN11-D</b>	-
<b>ML12</b>	<b>ML12</b>	<b>ML12</b>
-	<b>ML12A-SVJCR13-D</b>	-
<b>ML16</b>	<b>ML16</b>	<b>ML16</b>
-	<b>ML16A-SVJCR13-D</b>	<b>ML16A-SVJCR13-JET-D</b>

Porte-plaquettes  
WSP-Halter  
Insert holders

EVOCUT-Line

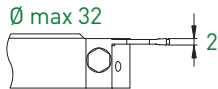

EVOCUT-Line  
ET20..

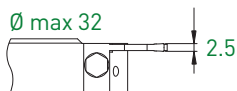

EVOCUT-Line  
ET25..

		-JET (-D)
Art. N°	Art. N°	Art. N°
<b>ML16</b>	<b>ML16</b>	<b>ML16</b>
-	-	<b>ML16A-ET20-JET32</b>
<b>ML16</b>	<b>ML16</b>	<b>ML16</b>
-	-	<b>ML16A-ET25-JET32</b>



Porte-plaquettes

WSP-Halter

Insert holders

EVOCUT-Line

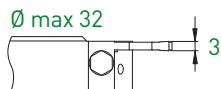

EVOCUT-Line  
ET30..

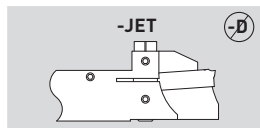

Art. N°	Art. N°	Art. N°
ML16	ML16	ML16
-	-	ML16A-ET30-JET32

Porte-plaquettes

WSP-Halter

Insert holders

CUT-Line

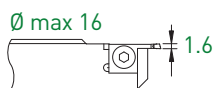

CUT-Line  
CUT16..

Standard		
Art. N°	Art. N°	Art. N°
ML12	ML12	ML12
ML12A-CUT16	-	-
ML12F-CUT16	-	-
ML16	ML16	ML16
ML16A-CUT16	-	-
ML16F-CUT16	-	-



CUT-Line  
CUT22..

ML12	ML12	ML12
ML12A-CUT22	-	-
ML12F-CUT22	-	-
ML16	ML16	ML16
ML16A-CUT22	-	-
ML16F-CUT22	-	-

# MODU-LINE

Porte-plaquettes  
WSP-Halter  
Insert holders

PRO-Line

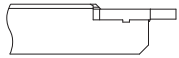

PRO-Line  
642-647

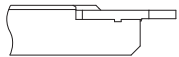

PRO-Line  
661

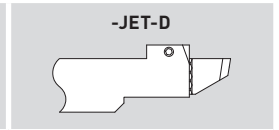
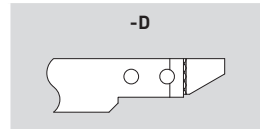

Art. N°	Art. N°	Art. N°
ML12	ML12	ML12
-	ML12A-640-D	ML12A-640-JET-D
ML16	ML16	ML16
-	ML16A-640-D	ML16A-640-JET-D

ML12	ML12	ML12
-	ML12A-660-D	ML12A-660-JET-D
ML16	ML16	ML16
-	ML16A-660-D	ML16A-660-JET-D

Porte-plaquettes  
WSP-Halter  
Insert holders

ECO-Line

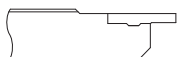

ECO-Line  
261-266

Standard	-D	-JET-D
Art. N°	Art. N°	Art. N°
ML12	ML12	ML12
ML12A-260	ML12A-260-D	ML12A-260-JET-D
ML12F-260	ML12F-260-D	-
ML16	ML16	ML16
ML16A-260	ML16A-260-D	ML16A-260-JET-D
ML16F-260	-	-

Porte-outils

Halter

Holder

IN-Line

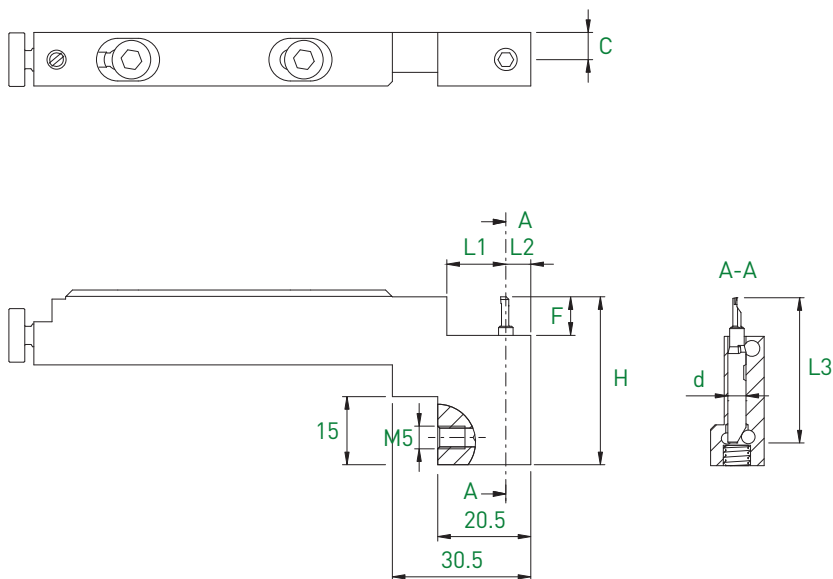

								ML12
d	Compatible bars	L3	F	H	C	L1	L2	Art. N°
4	BB4R... BF4R...	32	8.5	37	6	13	5.5	ML12A-BHK4N-32R-D
		37	13.5	42	6	13	5.5	ML12A-BHK4N-37R-D
		42	18.5	47	6	13	5.5	ML12A-BHK4N-42R-D

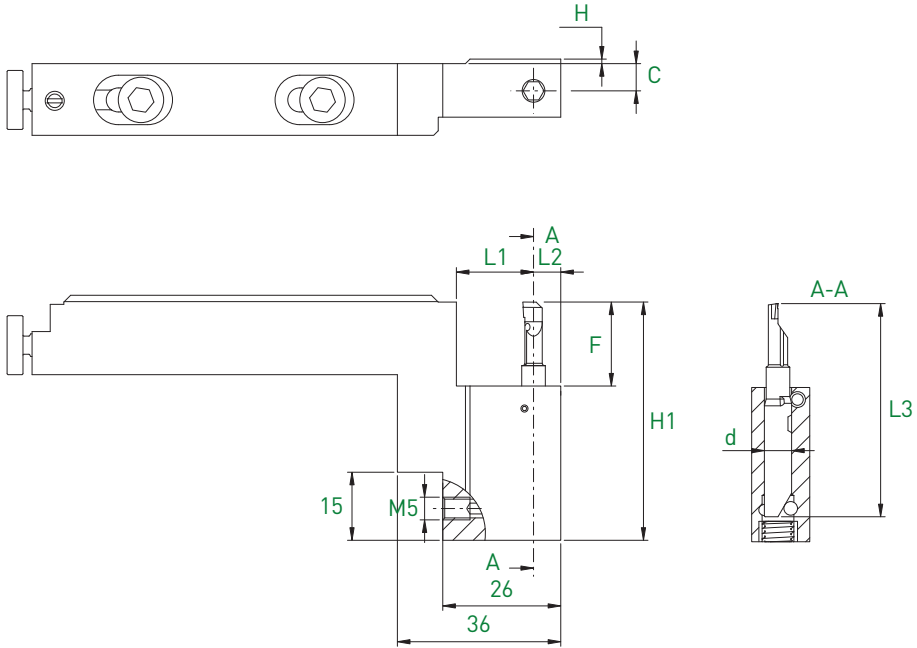

									ML16
d	Compatible bars	L3	F	H1	C	H	L1	L2	Art. N°
4	BB4R... BF4R...	32	8.5	37	6	-	17.5	5.5	ML16A-BHK4N-32R-D
		37	13.5	42	6	-	17.5	5.5	ML16A-BHK4N-37R-D
		42	18.5	47	6	-	17.5	5.5	ML16A-BHK4N-42R-D

									ML16
d	Compatible bars	L3	F	H1	C	H	L1	L2	Art. N°
6	BB4R... BF4R...	47	18.5	52.5	6	1	17	6	ML16A-BHK6N-47R-D
		57	28.5	62.5	6	1	17	6	ML16A-BHK6N-57R-D

Porte-outils

Halter

Holder

TOOLING-Line

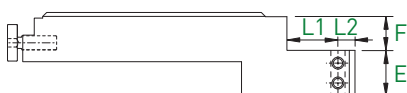
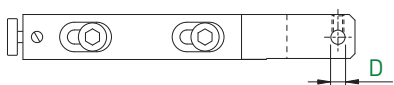

					ML12
F	D	E	L1	L2	Art. N°
8	3	12	13	6	ML12A-2440-8-3
8	4	12	13	6	ML12A-2440-8-4
8	5	12	13	6	ML12A-2440-8-5
12	6	12	13	6	ML12A-2440-12-6

					ML16
F	D	E	L1	L2	Art. N°
12	3	16	18	6	ML16A-2440-12-3
12	4	16	18	6	ML16A-2440-12-4
12	5	16	18	6	ML16A-2440-12-5
12	6	16	18	6	ML16A-2440-12-6
18	8	16	18	6	ML16A-2440-18-8

Porte-molettes

Rändelhalter

Knurl holders

TOOLING-Line

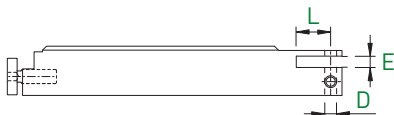
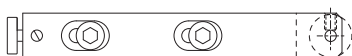

			ML12
E	D	L	Art. N°
4	4	8	ML12A-2402-44

			ML16
E	D	L	Art. N°
4	4	11	ML16A-2402-44

# MODU-LINE

Porte-plaquettes – Coupe déportée & contre-opération

WSP-Halter – Versetztes Schneiden & Gegenspindel

Insert holders – Cut off line & cut on subspindle

Coupe à droite déportée ou usinage à gauche sur contre-broche

Rechtsschneidend versetzt oder linksschneidend auf Gegenspindel

Right hand cut off line or left hand cut on subspindle

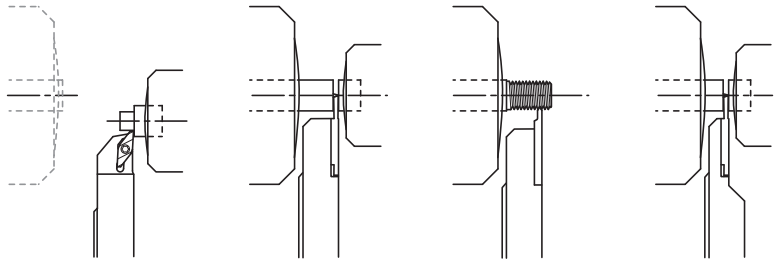

TURN-Line  
ISO-Line

TOP-Line  
EVOCUT-Line  
CUT-Line  
PRO-Line  
ECO-Line

TOP-Line  
EVOCUT-Line  
CUT-Line  
PRO-Line  
ECO-Line

TOP-Line  
PRO-Line  
ECO-Line

Porte-plaquettes – Coupe déportée & contre-opération



WSP-Halter – Versetztes Schneiden & Gegenspindel

Insert holders – Cut off line & cut on subspindle

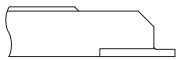
TOP-Line



TOP-Line  
731-737

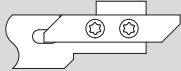



Standard	-D	-JET-D
		
Art. N°	Art. N°	Art. N°
ML12	ML12	ML12
ML12A-730-V	ML12A-730-V-D	ML12A-730-V-JET-D
ML16	ML16	ML16
ML16A-730-V	ML16A-730-V-D	ML16A-730-V-JET-D

Porte-plaquettes – Coupe déportée & contre-opération

WSP-Halter – Versetztes Schneiden & Gegenspindel

Insert holders – Cut off line & cut on subspindle

TOP-Line

Standard	-D	-JET 
		
Art. N°	Art. N°	Art. N°
ML12	ML12	ML12
ML12A-730RC	-	ML12A-730RC-JET

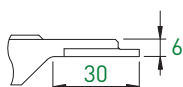

TOP-Line  
731R

ML16	ML16	ML16
ML16A-730RC	ML16A-730RC-D	ML16A-730RC-JET-D

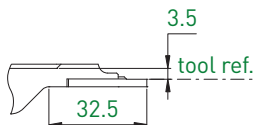

TOP-Line  
731R

ML12	ML12	ML12
ML12A-730RC-R04	-	-
ML12A-730RC-SWISS-NANO	-	-



TOP-Line  
751-757

ML12	ML12	ML12
ML12A-750-V	ML12A-750-V-D	ML12A-750-V-JET-D
ML16	ML16	ML16
ML16A-750-V	ML16A-750-V-D	ML16A-750-V-JET-D

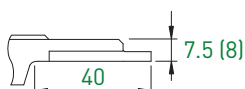

TOP-Line  
751R

ML12	ML12	ML12 
ML12A-750RC	-	ML12A-750RC-JET
ML16	ML16	ML16
ML16A-750RC	ML16A-750RC-D	ML16A-750RC-JET-D



# MODU-LINE

Porte-plaquettes – Coupe déportée & contre-opération  
 WSP-Halter – Versetztes Schneiden & Gegenspindel  
 Insert holders – Cut off line & cut on subspindle

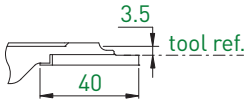
TOP-Line

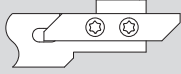

TOP-Line  
751R

Standard	-D	-JET-D
		
Art. N°	Art. N°	Art. N°
ML12	ML12	ML12
ML12A-750RC-R04	-	-
ML12A-750RC-SWISS-NANO	-	-

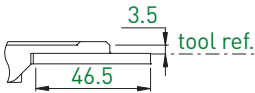

TOP-Line  
771R



ML12	ML12	ML12
ML12A-770RC-SWISS-NANO	-	-

Porte-plaquettes – Contre-opération  
 WSP-Halter – Gegenspindel  
 Insert holders – Cut on subspindle

TURN-Line



TURN-Line  
337-339

Standard	-D	-JET-D
		
Art. N°	Art. N°	Art. N°
ML12	ML12	ML12
ML12A-330-V	ML12A-330-V-D	ML12A-330-V-JET-D
ML16	ML16	ML16
ML16A-330-V	ML16A-330-V-D	ML16A-330-V-JET-D



Porte-plaquettes – Contre-opération

WSP-Halter – Gegenspindel

Insert holders – Cut on subspindle

ISO-Line

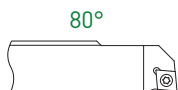

ISO-Line  
CC...0602..

Standard	-D	-JET-D
Art. N°	Art. N°	Art. N°
ML12	ML12	ML12
-	ML12A-SCLCL06-V-D	ML12A-SCLCL06-V-JET-D
ML16	ML16	ML16
-	ML16A-SCLCL06-V-D	ML16A-SCLCL06-V-JET-D

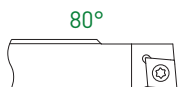

ISO-Line  
CC...9T3..

ML12	ML12	ML12
-	ML12A-SCLCL09-V-D	ML12A-SCLCL09-V-JET-D
ML16	ML16	ML16
-	ML16A-SCLCL09-V-D	ML16A-SCLCL09-V-JET-D

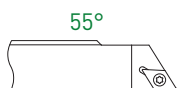

ISO-Line  
DC...0702..

ML12	ML12	ML12
-	ML12A-SDJCL07-V-D	ML12A-SDJCL07-V-JET-D
ML16	ML16	ML16
-	ML16A-SDJCL07-V-D	ML16A-SDJCL07-V-JET-D

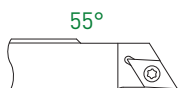

ISO-Line  
DC...11T3..

ML12	ML12	ML12
ML12A-SDJCL11-V	ML12A-SDJCL11-V-D	ML12A-SDJCL11-V-JET-D
ML16	ML16	ML16
ML16A-SDJCL11-V	ML16A-SDJCL11-V-D	ML16A-SDJCL11-V-JET-D

# MODU-LINE

Porte-plaquettes – Contre-opération

WSP-Halter – Gegenspindel

Insert holders – Cut on subspindle

ISO-Line

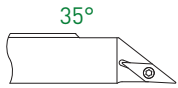

35°

ISO-Line  
VC...-1103..

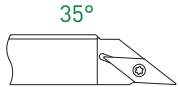

35°

ISO-Line  
VC...-1303..

Standard	-D	-JET-D
Art. N°	Art. N°	Art. N°
ML12	ML12	ML12
ML12A-SVJCL11-V	ML12A-SVJCL11-V-D	ML12A-SVJCL11-V-JET-D
ML16	ML16	ML16
ML16A-SVJCL11-V	ML16A-SVJCL11-V-D	ML16A-SVJCL11-V-JET-D

ML12	ML12	ML12
-	ML12A-SVJCL13-V-D	-
ML16	ML16	ML16
-	ML16A-SVJCL13-V-D	ML16A-SVJCL13-V-JET-D

Porte-plaquettes – Coupe déportée

WSP-Halter – Versetztes Schneiden

Insert holders – Cut off line

EVOCUT-Line

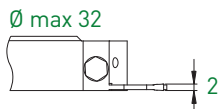

Ø max 32

EVOCUT-Line  
ET20

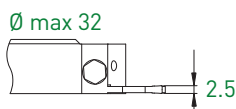

Ø max 32

EVOCUT-Line  
ET25

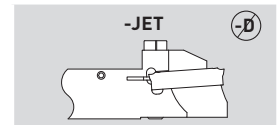

Art. N°	Art. N°	Art. N°
ML16	ML16	ML16
-	-	ML16A-ET20-V-JET32

ML16	ML16	ML16
-	-	ML16A-ET25-V-JET32

- Porte-plaquettes – Coupe déportée
- WSP-Halter – Versetztes Schneiden
- Insert holders – Cut off line

EVOCUT-Line

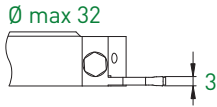

EVOCUT-Line  
ET30

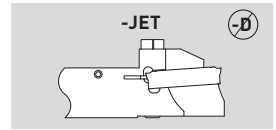

ML16	ML16	ML16
-	-	ML16A-ET30-V-JET32

- Porte-plaquettes – Coupe déportée
- WSP-Halter – Versetztes Schneiden
- Insert holders – Cut off line

CUT-Line

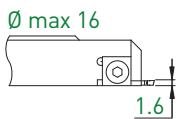

CUT-Line  
CUT16

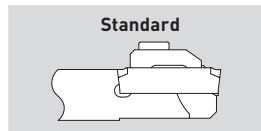

Art. N°	Art. N°	Art. N°
ML12	ML12	ML12
ML12A-CUT16-V	-	-
ML12F-CUT16-V	-	-
ML16	ML16	ML16
ML16A-CUT16-V	-	-
ML16F-CUT16-V	-	-

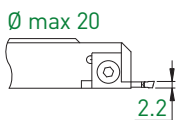

CUT-Line  
CUT22

ML12	ML12	ML12
ML12A-CUT22-V	-	-
ML12F-CUT22-V	-	-
ML16	ML16	ML16
ML16A-CUT22-V	-	-
ML16F-CUT22-V	-	-

Porte-plaquettes – Coupe déportée & contre-opération



WSP-Halter – Versetztes Schneiden & Gegenspindel

Insert holders – Cut off line & cut on subspindle

PRO-Line



PRO-Line  
632-636

Standard	-D	-JET-D
		
Art. N°	Art. N°	Art. N°
ML12	ML12	ML12
-	ML12A-630-V-D	ML12A-630-V-JET-D
ML16	ML16	ML16
-	ML16A-630-V-D	ML16A-630-V-JET-D

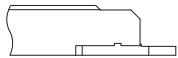

PRO-Line  
651R

ML12	ML12	ML12
-	ML12A-650-V-D	ML12A-650-V-JET-D
ML16	ML16	ML16
-	ML16A-650-V-D	ML16A-650-V-JET-D

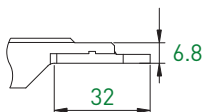

PRO-Line  
651R

ML12	ML12	ML12
ML12A-650RC	ML12A-650RC-D	-
ML16	ML16	ML16
-	ML16A-650RC-D	ML16A-650RC-JET-D

Porte-plaquettes – Coupe déportée & contre-opération



WSP-Halter – Versetztes Schneiden & Gegenspindel

Insert holders – Cut off line & cut on subspindle

ECO-Line

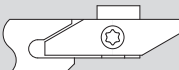

ECO-Line  
251-261

Standard	-D	-JET-D
		
Art. N°	Art. N°	Art. N°
ML12	ML12	ML12
ML12A-250-V	ML12A-250-V-D	ML12A-250-V-JET-D
ML16	ML16	ML16
ML16A-250-V	ML16A-250-V-D	ML16A-250-V-JET-D

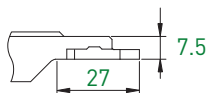

ECO-Line  
251R

ML12	ML12	ML12
-	ML12A-250RC-D	-
ML16	ML16	ML16
-	ML16A-250RC-D	-

# MODU-LINE

Modules d'arrosage  
Kühlmittelzufuhrelemente  
Coolant supply units

## ML12 / ML16

ML12

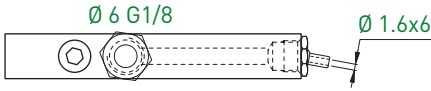

Raccord Anschluss Connection	Buses d'arrosage Kühlmitteldüse Coolant nozzles	ML12 Art. N°
Ø 6 G 1/8	5/16"	ML12-JET-5/16

ML16

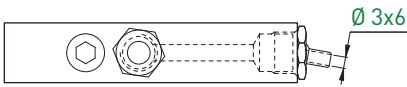

Raccord Anschluss Connection	Buses d'arrosage Kühlmitteldüse Coolant nozzles	ML16 Art. N°
Ø 6 G 1/8	7/16"	ML16-JET-7/16

buses optionnelles voir page 12.81  
zusätzliche Düsen siehe Seite 12.81  
optional nozzles see page 12.81

Modules de serrage  
Spannelemente  
Clamping units

## ML12 / ML16

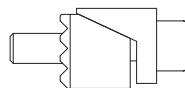
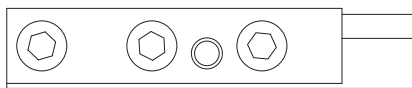

ML12 Art. N°	ML16 Art. N°
ML12-FIX-12/14	ML16-FIX-16/16
-	ML16-FIX-16/16.5
-	ML16-FIX-16/17
-	ML16-FIX-16/20
-	ML16-FIX-16/22
-	ML16-FIX-16/24

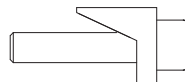
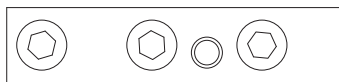

ML12 Art. N°	ML16 Art. N°
ML12-FIX-12	ML16-FIX-16

Buses d'arrosage

Kühlmitteldüsen

Coolant nozzles

5/16" / 7/16"

JET

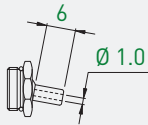
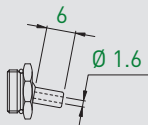
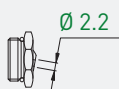
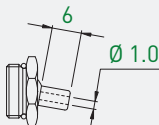
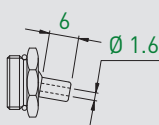
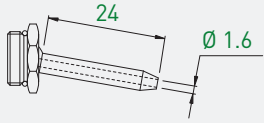
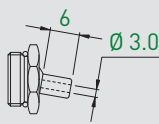
5/16"	Art. N°	Références compatibles Kompatible Artikeln Compatible items
	ML-JET 5/16-1.0X6	ML12-JET-5/1.6
	ML-JET 5/16-1.6X6	une buse <b>ML-JET-5/16-1.6x6</b> est comprise eine Düse <b>ML-JET-5/16-1.6x6</b> ist inbegriffen a nozzle <b>ML-JET-5/16-1.6x6</b> is included
	ML-JET 5/16-2.2X0	
7/16"	Art. N°	Références compatibles Kompatible Artikeln Compatible items
	ML-JET 7/16-1.0X6	
	ML-JET 7/16-1.6X6	ML16-KMX26-JET ML16-JET-7/16 ML12-DEC010-JET ML16-DEC013-JET ML16-DEC020-JET ML16-S20-JET ML16-SWISS-ST26-JET
	ML-JET-7/16-1.6X24	une buse <b>ML-JET-7/16-3.0x6</b> est comprise avec chaque article ci-dessus eine Düse <b>ML-JET 7/16-3.0x6</b> ist mit jedem vorstehenden Artikel inbegriffen
	ML-JET-7/16-3.0X6	a nozzle <b>ML-JET 7/16-3.0x6</b> is included with each above item

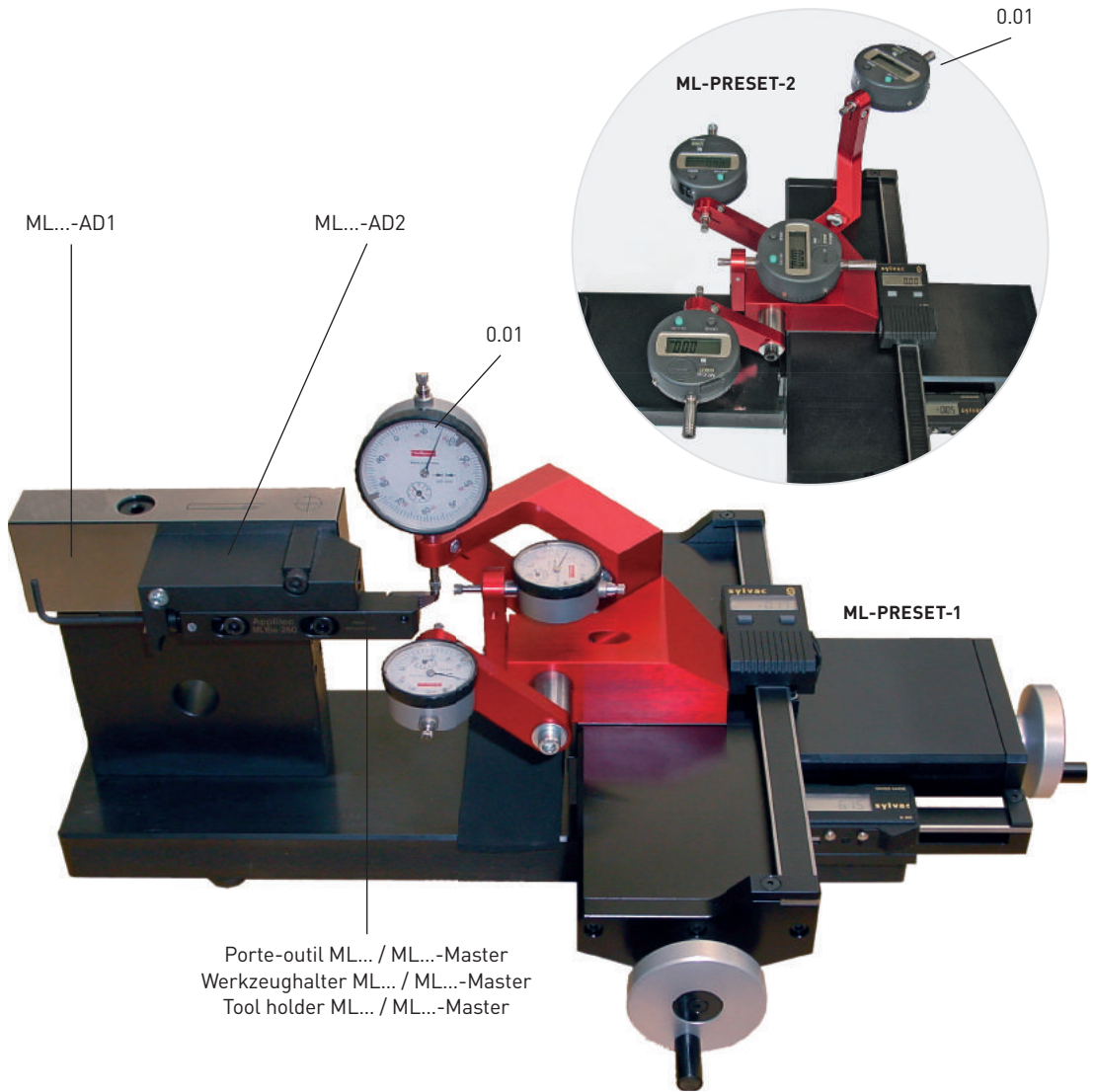

Art. N°

ML-PRESET-1

ML-PRESET-2



**Banc de pré réglage**

**Voreinstellgerät**

**Presetting device**

**ML12 / ML16**

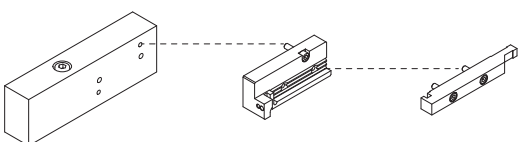
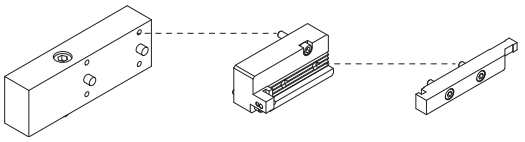
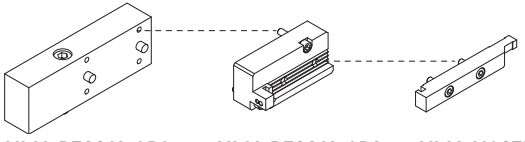
Type Typ Type	Fabricant Hersteller Manufacturer	Machines Maschinen Machines	Adaptateurs et jauges d'étalonnage Adapter und Einstellehre Adaptators and master gauges	
ML12	CITIZEN	C12/C16	 <p><b>ML12-AD1</b>      <b>ML12-AD2</b>      <b>ML12-MASTER</b></p>	
		L12-1M7		
		L12-2M10		
		M16 V/VIII		
		R04		
		R07		
	HANWHA	XD20M		
	METAFIL	D3/D10/D13		
		SB-12RG		
	STAR	SR10-J		
		SW-12RII		
	TORNOS	DECO7/10 - EvoDECO 10		
		SwissNano/SwissNano 7		
		DT13		
		CT20		
		GT13		
TSUGAMI	B074			
	B075			
	P034			
ML16	CITIZEN	K12/K16/K12E/K16E	 <p><b>ML16/20-AD1</b>      <b>ML16-AD2</b>      <b>ML16-MASTER</b></p>	
		L16/L20		
		L20E		
	HANWHA	SL12/16		
	MANUHRIN	KMX 426/526/626/Swing 20-26 MM		
		SA-12/SA-16/SA-16R		
		SB-16		
		SB-16/20RG		
		SB-20C/E		
		SR-20J/SR-20RIII		
		SR-20JII-A/B		
		SR-16R/SR-20R/SR-20RII		
		SR-20RIII/SR-20J		
		SR-20RIV		
		SR-32J		
		SV-12/20/ SV-20R		
		SW-20R		
		TORNOS		DECO20/26 - EvoDECO20/32
				SIGMA20/32
				DT26
GT26				
GT32				
ML16	TORNOS	DECO13-EvoDECO16	 <p><b>ML16-DECO13-AD1</b>      <b>ML16-DECO13-AD2</b>      <b>ML16-MASTER</b></p>	
		ST26		

### ML12

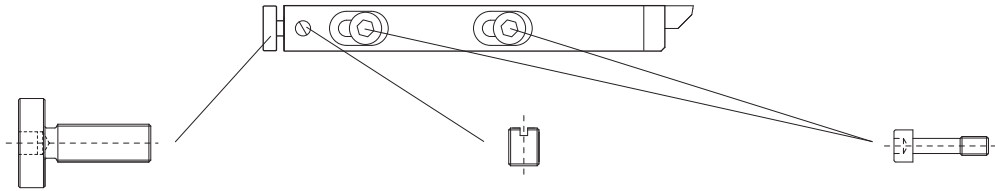

Vis de réglage  
Einstellungsschraube  
Setting screw

Art. N°

ML12A-M5X0.5

Vis de blocage  
Blockierschraube  
Locking screw

Art. N°

ML-M4X4-T

Vis de fixation  
Befestigungsschraube  
Fixing screw

Art. N°

ML12-M5XL20

### ML16

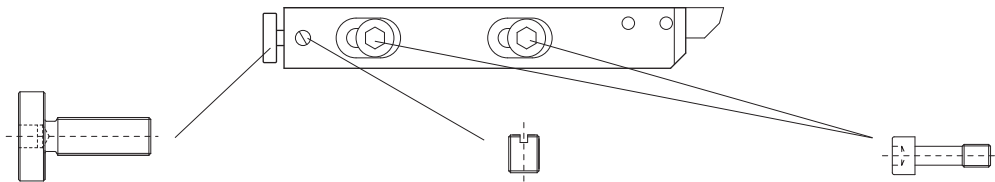

Vis de réglage  
Einstellungsschraube  
Setting screw

Art. N°

ML16A-M5X0.5

Vis de blocage  
Blockierschraube  
Locking screw

Art. N°

ML-M4X4-T

Vis de fixation  
Befestigungsschraube  
Fixing screw

Art. N°

ML16/20-M6XL20

Art. N°

ML-205004



Butée à ressort  
Federnde Schraube  
Spring bumper

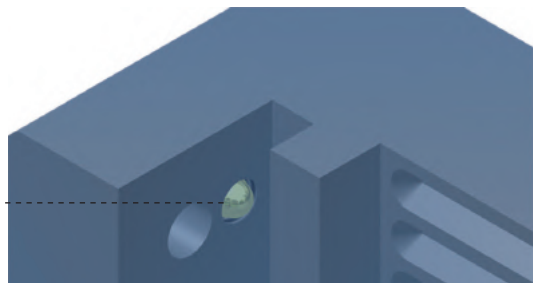





Pièces de rechange

Ersatzteile

Spare parts

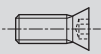
ML12 / ML16

Vis et clés pour le serrage des plaquettes  
Schrauben und Schlüssel für WSP-Befestigung  
Screws and keys for insert clamping

Porte-outils Halter Holders					
ML...250	<b>V-M4X9-T15</b>	<b>C-T15</b>	-	-	-
ML...260	<b>V-M4X9-T15</b>	<b>C-T15</b>	-	-	-
ML...330	<b>V-M2.5X7.8-T8</b>	<b>C-T8</b>	-	-	-
ML...340	<b>V-M2.5X7.8-T8</b>	<b>C-T8</b>	-	-	-
ML...630	<b>V-M4X9-T15</b>	<b>C-T15</b>	-	-	-
ML...640	<b>V-M4X9-T15</b>	<b>C-T15</b>	-	-	-
ML...650	<b>V-M4X9-T15</b>	<b>C-T15</b>	-	-	-
ML...650RC	<b>V-M4X6.5-T15</b>	<b>C-T15</b>	-	-	-
ML...660	<b>V-M4X9-T15</b>	<b>C-T15</b>	-	-	-
ML...730	<b>V-M3X7-T8</b>	<b>C-T8</b>	-	-	-
ML...730RC	<b>V-M3X5.5-T8</b>	<b>C-T8</b>	-	-	-
ML...730RC-R04	<b>V-M3X4.5-T8</b> <b>V-M3X7-T8</b>	<b>C-T8</b>	-	-	-
ML...730RC-SWISS-NANO	<b>V-M3X4.5-T8</b> <b>V-M3X7-T8</b>	<b>C-T8</b>	-	-	-
ML...740	<b>V-M3X7-T8</b>	<b>C-T8</b>	-	-	-
ML...750	<b>V-M4X9-T15</b>	<b>C-T15</b>	-	-	-
ML...750RC	<b>V-M4X7.3-T15</b>	<b>C-T15</b>	-	-	-
ML...750RC-R04	<b>V-M4X5.6-T15</b> <b>V-M4X7.3-T15</b>	<b>C-T15</b>	-	-	-
ML...750RC-SWISS-NANO	<b>V-M4X5.6-T15</b> <b>V-M4X7.3-T15</b>	<b>C-T15</b>	-	-	-
ML...760	<b>V-M4X9-T15</b>	<b>C-T15</b>	-	-	-
ML...770RC-SWISS-NANO	<b>V-M4X7.3-T15</b>	<b>C-T15</b>	-	-	-
ML...780	<b>V-M4X9-T15</b>	<b>C-T15</b>	-	-	-
ML...SC...06	<b>V-M2.5X5.8-T8</b>	<b>C-T8</b>	-	-	-
ML...SC...09	<b>V-M4X7-T15-ISO</b>	<b>C-T15</b>	-	-	-
ML...-SD...07	<b>V-M2.5X7.8-T8</b>	<b>C-T8</b>	-	-	-
ML...-SD...07-D	<b>V-M2.5X5.8-T8</b>	<b>C-T8</b>	-	-	-
ML12...-SDJ...11	<b>V-M4X7-T15-ISO</b>	<b>C-T15</b>	-	-	-
ML12...-SDN...11	<b>V-M4X9-T15-ISO</b>	<b>C-T15</b>	-	-	-
ML16...-SD...11	<b>V-M4X9-T15-ISO</b>	<b>C-T15</b>	-	-	-
ML...-SV...11	<b>V-M2.5X7.8-T8</b>	<b>C-T8</b>	-	-	-
ML...-SV...13	<b>V-M3X7.3-T8-ISO</b>	<b>C-T8</b>	-	-	-
ML...-CUT16	-	-	<b>CUT16RS-SET</b>	-	-
ML...-CUT16-V	-	-	<b>CUT16LS-SET</b>	-	-
ML...-CUT22	-	-	<b>CUT22RS-SET</b>	-	-
ML...-CUT16-V	-	-	<b>CUT22LS-SET</b>	-	-
ML16...-ET... JET32	-	-	-	-	-
ML16...-ET... V-JET32	-	-	-	<b>V-M5X21-6P7-J</b>	<b>C-6PEX-7.0</b>
ML...-BHK	<b>V-BHK-M4X0.5-T8</b>	-	-	-	-

**Outils et porte-outils traditionnels pour le décolletage et la mécanique de précision**

- Porte-outils
- Forets à centrer
- Burins intérieurs
- Porte-molettes
- Molettes MD

**Übliche Werkzeuge und Halter für Decolletage und Präzisionsmechanik**

- Werkzeughalter
- Zentrierbohrer
- Innendrehwerkzeuge
- Rändelhalter
- Rändelrädchen

**Usual tools and tool holders for automatic lathes and precision mechanics**

- Tool holders
- Centring drills
- Internal turning tools
- Knurl holders
- Knurling wheels



Index

Porte-outils  
Werkzeughalter  
Tool holders

**Type 14xx / 24xx**



> 13.02

Porte-outils monoblocs pour machines Tornos  
Monoblockwerkzeughalter für Tornos Maschinen  
Monobloc tool holders for Tornos machines

**Type 2435 / 2436**



> 13.12

Forets à centrer plats  
Zentrierflachbohrer  
Centering flat drills

**Type 1200 / 2200**



> 13.14

Forets à centrer hélicoïdaux  
Zentrierspiralbohrer  
Centering twist drills

**Type 15xx / 25xx**



> 13.15

Burins intérieurs en métal dur  
Vollhartmetall Innendrehwerkzeuge  
Solid carbide internal turning tools

**Type 16xx / 26xx**

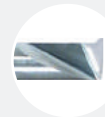

> 13.16

Porte-molettes  
Rändelhalter  
Knurl holders

**Type 1402 / 2402**



> 13.18

Molettes en métal dur  
Vollhartmetall Rändelrädchen  
Solid carbide knurling wheels

**Type 1107**



> 13.19

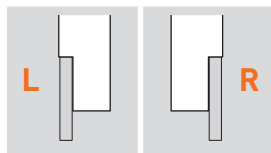
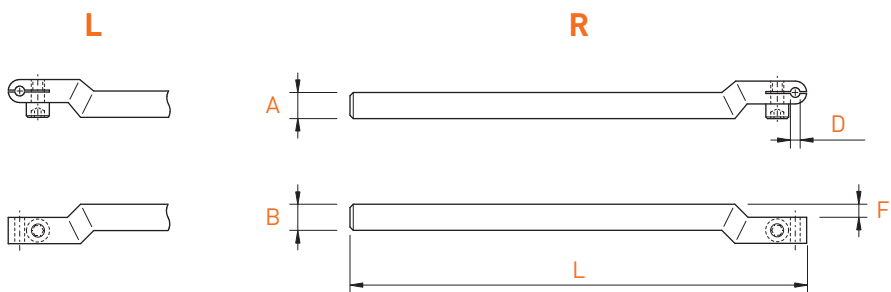

A x B	L	F	D	Art. N°	Art. N°
6 x 6	132	3	1.5	1400-J-615	2400-J-615
6 x 6	132	3	2.0	1400-J-620	2400-J-620
6 x 6	132	3	3.0	1400-J-630	2400-J-630
7 x 7	140	3	1.5	1400-J-715	2400-J-715
7 x 7	140	3	2.0	1400-J-720	2400-J-720
7 x 7	140	3	3.0	1400-J-730	2400-J-730
8 x 8	140	4	1.5	1400-J-815	2400-J-815
8 x 8	140	4	2.0	1400-J-820	2400-J-820
8 x 8	140	4	3.0	1400-J-830	2400-J-830

Porte-outils  
 Werkzeughalter  
 Tool holders

1401-K / 2401-K

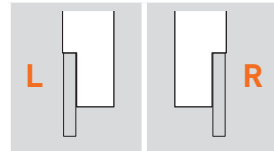
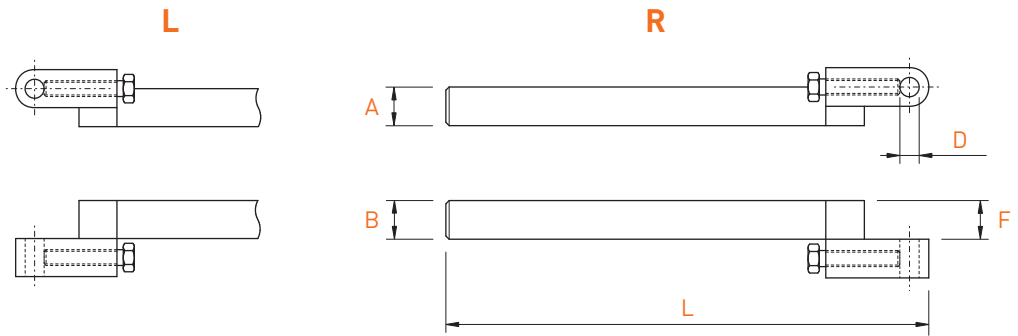

A x B	L	F	D	Art. N°	Art. N°
7 x 7	146	7	2.0	1401-K-720	-
7 x 7	146	7	3.0	1401-K-730	2401-K-730
7 x 7	146	7	4.0	1401-K-740	2401-K-740
8 x 8	146	8	2.0	1401-K-820	-
8 x 8	146	8	3.0	1401-K-830	2401-K-830
8 x 8	146	8	4.0	1401-K-840	2401-K-840
8 x 8	146	8	5.0	1401-K-850	2401-K-850
8 x 8	146	8	6.0	1401-K-860	2401-K-860
10 x 10	150	10	3.0	-	2401-K-1030
10 x 10	150	10	4.0	1401-K-1040	2401-K-1040
10 x 10	150	10	5.0	1401-K-1050	2401-K-1050
10 x 10	150	10	6.0	1401-K-1060	2401-K-1060
10 x 10	150	10	7.0	1401-K-1070	2401-K-1070
12 x 12	150	12	3.0	-	2401-K-1230
12 x 12	150	12	4.0	1401-K-1240	2401-K-1240
12 x 12	150	12	5.0	1401-K-1250	2401-K-1250
12 x 12	150	12	6.0	1401-K-1260	2401-K-1260
12 x 12	150	12	8.0	1401-K-1280	2401-K-1280
14 x 14	150	14	4.0	1401-K-1440	2401-K-1440
14 x 14	150	14	6.0	1401-K-1460	2401-K-1460
14 x 14	150	14	8.0	1401-K-1480	2401-K-1480

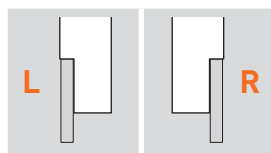
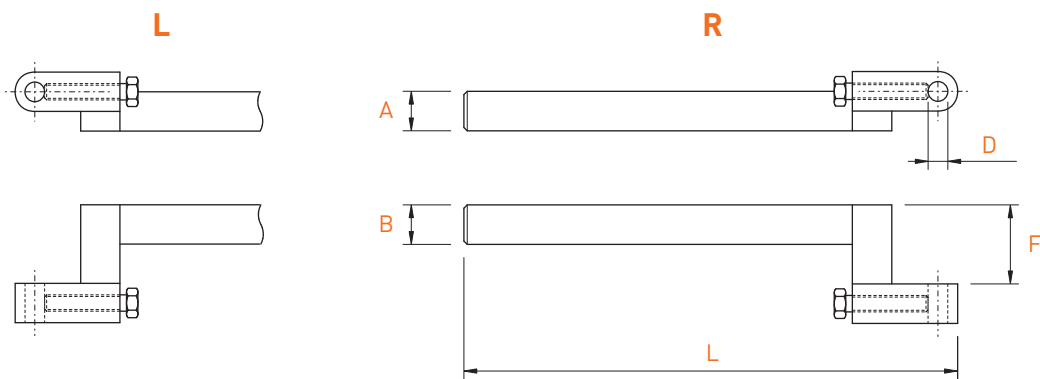

A x B	L	F	D	Art. N°	Art. N°
7 x 7	146	12	4.0	1420-7124	2420-7124
8 x 8	146	12	4.0	1420-8124	2420-8124
8 x 8	146	14	3.0	1420-8143	2420-8143
8 x 8	146	15	5.0	1420-8155	2420-8155
8 x 8	146	20	5.0	1420-8205	2420-8205
10 x 10	150	20	6.0	1420-10206	2420-10206
12 x 12	150	18	6.0	1420-12186	2420-12186
12 x 12	150	18	8.0	1420-12188	-
12 x 12	150	24	8.0	1420-12248	2420-12248
14 x 14	150	20	8.0	1420-14208	2420-14208
14 x 14	150	24	8.0	1420-14248	2420-14248



Porte-outils

Werkzeughalter

Tool holders

∅ 12 x 12

1460

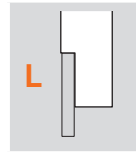
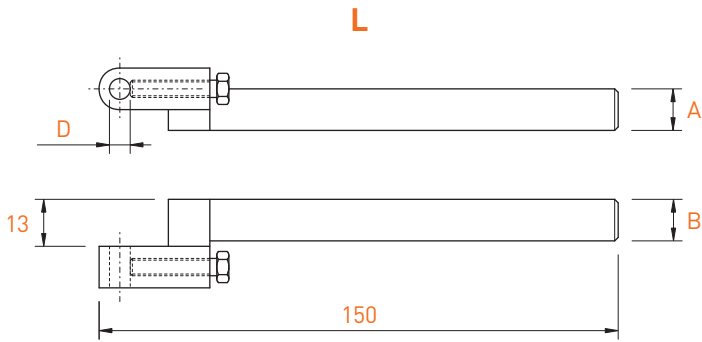

A x B	D	Art. N°
12 x 12	4.0	1460-4
12 x 12	5.0	1460-5
12 x 12	6.0	1460-6
12 x 12	8.0	1460-8

# TOOLING-LINE

Porte-outils  
Werkzeughalter  
Tool holders

∅ 10 x 10

2450-SP

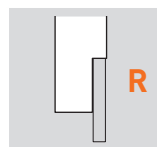
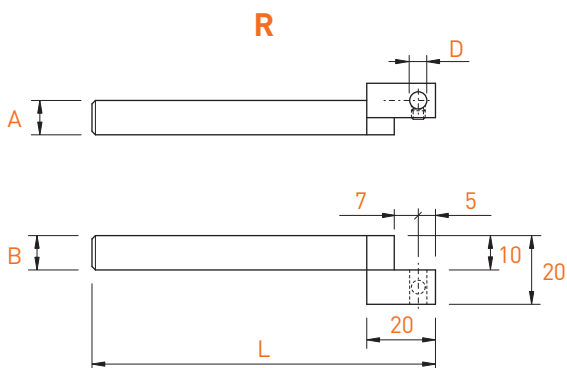

A x B	L	D	Art. N°
10 x 10	100	3.0	2450-SP-3
10 x 10	100	4.0	2450-SP-4
10 x 10	100	5.0	2450-SP-5
10 x 10	100	6.0	2450-SP-6
10 x 10	120	3.0	2450-SP-3-120
10 x 10	120	4.0	2450-SP-4-120
10 x 10	120	5.0	2450-SP-5-120
10 x 10	120	6.0	2450-SP-6-120

Porte-outils  
Werkzeughalter  
Tool holders

∅ 10 x 10

2470

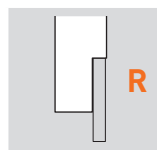
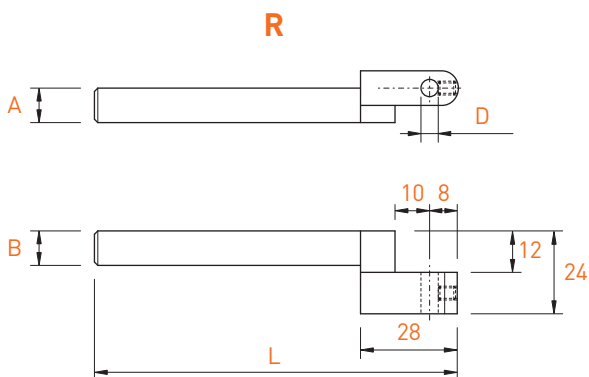

A x B	L	D	Art. N°
10 x 10	105	3.0	2470-3
10 x 10	105	4.0	2470-4
10 x 10	105	5.0	2470-5
10 x 10	105	6.0	2470-6
10 x 10	105	7.0	2470-7

Porte-outils  
Werkzeughalter  
Tool holders

∅ 12 x 12

2450

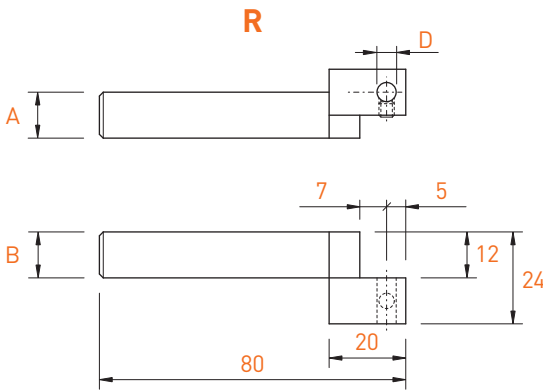

A x B	D	Art. N°
12 x 12	3.0	2450-3
12 x 12	4.0	2450-4
12 x 12	5.0	2450-5
12 x 12	6.0	2450-6
12 x 12	8.0	2450-8

Porte-outils  
Werkzeughalter  
Tool holders

∅ 12 x 12

2460

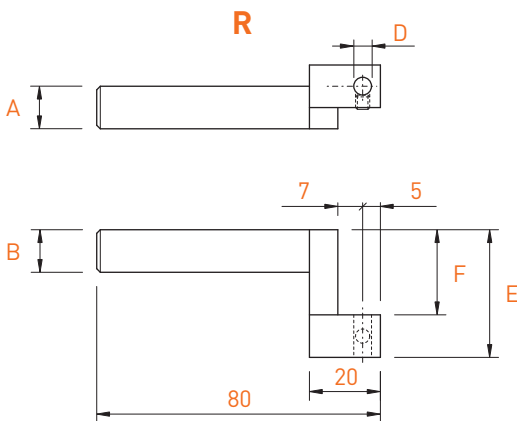

A x B	F	E	D	Art. N°
12 x 12	16	28	4.0	2460-284
12 x 12	16	28	6.0	2460-286
12 x 12	16	28	8.0	2460-288
12 x 12	20	32	4.0	2460-324
12 x 12	20	32	6.0	2460-326
12 x 12	20	32	8.0	2460-328
12 x 12	24	36	4.0	2460-364
12 x 12	24	36	6.0	2460-366
12 x 12	24	36	8.0	2460-368



A x B	L	F	D	Art. N°
8 x 8	120	8	3.0	2405-K-830
8 x 8	120	8	4.0	2405-K-840
8 x 8	120	8	5.0	2405-K-850
8 x 8	120	8	6.0	2405-K-860
10 x 10	100	10	4.0	2405-K-1040
10 x 10	100	10	5.0	2405-K-1050
10 x 10	100	10	6.0	2405-K-1060
12 x 12	150	12	4.0	2405-K-1240
12 x 12	150	12	6.0	2405-K-1260
12 x 12	150	12	8.0	2405-K-1280

Porte-outils

Werkzeughalter

Tool holders

2425



A x B	L	F	D	Art. N°
8 x 8	120	12	4.0	2425-8124
8 x 8	120	15	5.0	2425-8155
8 x 8	120	20	5.0	2425-8205
10 x 10	100	15	6.0	2425-10156
10 x 10	100	20	6.0	2425-10206
12 x 12	150	18	6.0	2425-12186
12 x 12	150	24	8.0	2425-12248

# TOOLING-LINE

Porte-outils  
Werkzeughalter  
Tool holders

□ 12 x 16

2441



A x B	D	Art. N°
12 x 16	3.0	2441-0-3
12 x 16	4.0	2441-0-4
12 x 16	5.0	2441-0-5
12 x 16	6.0	2441-0-6

Porte-outils  
Werkzeughalter  
Tool holders

□ 16 x 16

2440-0



A x B	D	Art. N°
16 x 16	3.0	2440-0-3
16 x 16	4.0	2440-0-4
16 x 16	5.0	2440-0-5
16 x 16	6.0	2440-0-6



# TOOLING-LINE

Porte-outils pour machines Tornos DECO 7/10 / EvoDECO 10

Werkzeughalter für Tornos DECO 7/10 / EvoDECO 10 Maschinen

Tool holders for Tornos DECO 7/10 / EvoDECO 10 machines

## 2435 / 2435-T

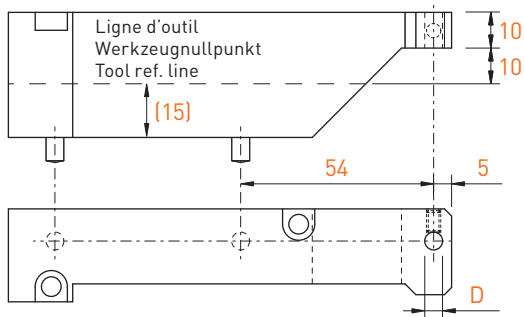

D	Art. N°
3.0	2435-3
4.0	2435-4
5.0	2435-5
6.0	2435-6

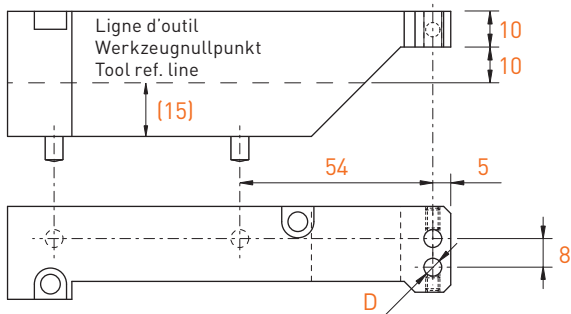

D	Art. N°
3.0	2435-3-T
4.0	2435-4-T
5.0	2435-5-T
6.0	2435-6-T



Porte-outils pour machines Tornos DECO 13 / EvoDECO 16

Werkzeughalter für Tornos DECO 13 / EvoDECO 16 Maschinen

Tool holders for Tornos DECO 13 / EvoDECO 16 machines

2436 / 2436T

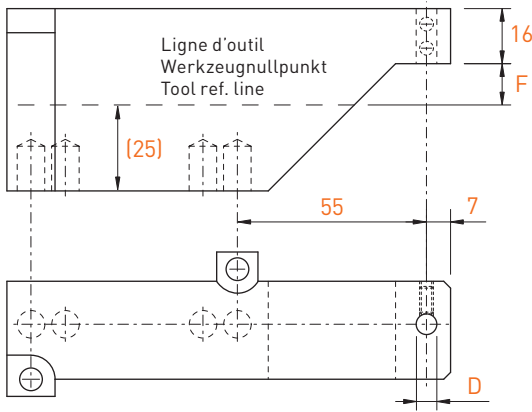

F	D	Art. N°
12	3.0	2436-12-3
12	4.0	2436-12-4
12	5.0	2436-12-5
12	6.0	2436-12-6
12	8.0	2436-12-8
18	3.0	2436-18-3
18	4.0	2436-18-4
18	5.0	2436-18-5
18	6.0	2436-18-6
18	8.0	2436-18-8

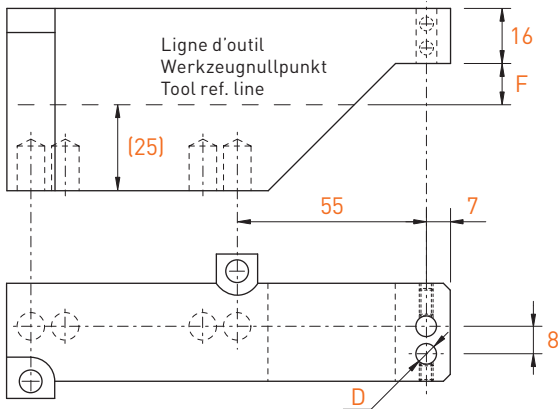

F	D	Art. N°
12	3.0	2436T-12-3
12	4.0	2436T-12-4
12	5.0	2436T-12-5
12	6.0	2436T-12-6
18	3.0	2436T-18-3
18	4.0	2436T-18-4
18	5.0	2436T-18-5
18	6.0	2436T-18-6

Entretroise

Erhöhungplatte

Spacer

2436-S12

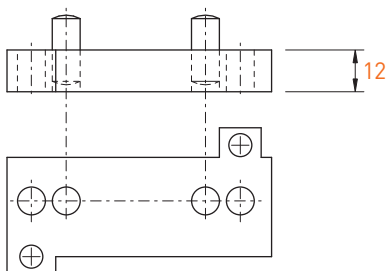

Art. N°

2436-S12

# TOOLING-LINE

Forets à centrer plats

Zentrierflachbohrer

Centering flat drills

90°

1200 / 2200

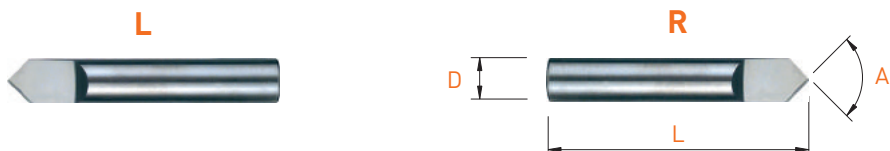

MD VHM HM			L	R
A	D	L	Art. N°	Art. N°
90°	3	17	1200-317	2200-317
90°	3	38	1200-338	2200-338
90°	4	40	1200-440	2200-440
90°	5	50	1200-550	2200-550
90°	6	50	1200-650	2200-650
90°	8	58	1200-858	2200-858
90°	10	66	1200-1066	2200-1066
90°	12	73	1200-1273	2200-1273

Forets à centrer hélicoïdaux  
 Zentrierspiralbohrer  
 Centering twist drills

90°

1500 / 2520

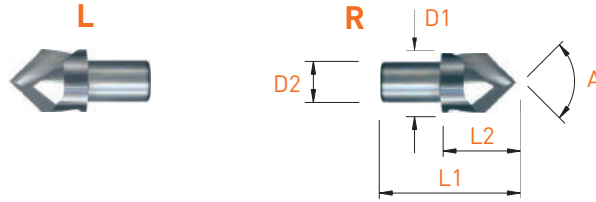

					HSS		MD / VHM / HM	
					L	R	L	R
A	D1	D2	L1	L2	Art. N°	Art. N°	Art. N°	Art. N°
90°	5	4	17	8	1500-5-HSS	2520-5-HSS	1500-5	2520-5
90°	7	5	17	8	1500-7-HSS	2520-7-HSS	1500-7	2520-7
90°	10	6	22	10	1500-10-HSS	2520-10-HSS	1500-10	2520-10
90°	12	8	26	12	1500-12-HSS	2520-12-HSS	1500-12	2520-12

Forets à centrer hélicoïdaux  
 Zentrierspiralbohrer  
 Centering twist drills

120°

1510 / 2530

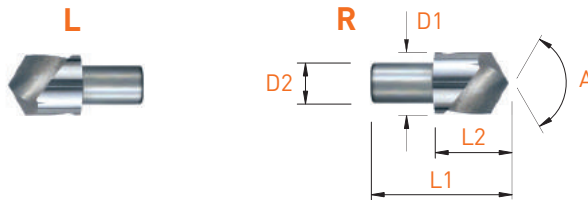

					MD VHM HM		L	R
A	D1	D2	L1	L2	Art. N°	Art. N°		
120°	5	4	17	8	1510-5	2530-5		
120°	7	5	17	8	1510-7	2530-7		
120°	10	6	22	10	1510-10	2530-10		
120°	12	8	26	12	1510-12	2530-12		

# TOOLING-LINE

Burins intérieurs en métal dur  
 Vollhartmetall Innendrehwerkzeuge  
 Solid carbide internal turning tools

1600 / 2620

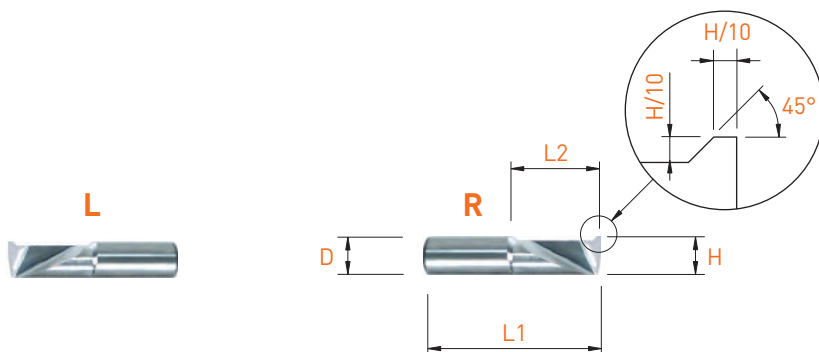

				L	R
				Art. N°	Art. N°
MD					
VHM					
HM					
H 0/-0.05	D	L1	L2	Art. N°	Art. N°
2	3	13	4	1600-2-4	2620-2-4
3	3	15	6	1600-3-6	2620-3-6
4	4	17	8	1600-4-8	2620-4-8
4	4	21	12	1600-4-12	2620-4-12
5	5	21	10	1600-5-10	2620-5-10
5	5	26	15	1600-5-15	2620-5-15
6	6	25	12	1600-6-12	2620-6-12
6	6	31	18	1600-6-18	2620-6-18
8	8	32	16	1600-8-16	2620-8-16
8	8	40	24	1600-8-24	2620-8-24

Burins intérieurs en métal dur  
 Vollhartmetall Innendrehwerkzeuge  
 Solid carbide internal turning tools

1610 / 2630

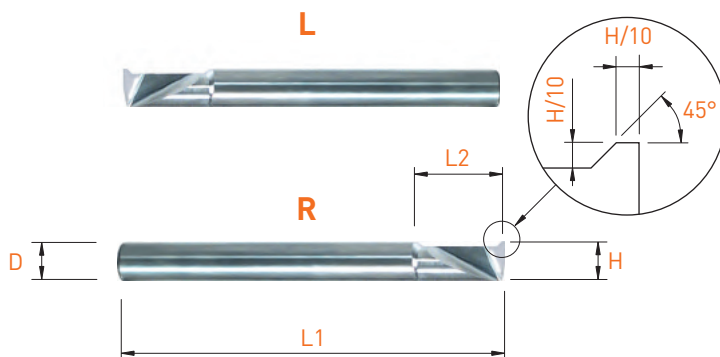

MD VHM HM				L	R
H 0/-0.05	D	L1	L2	Art. N°	Art. N°
2	3	38	4	1610-2-4	2630-2-4
3	3	38	6	1610-3-6	2630-3-6
4	4	40	8	1610-4-8	2630-4-8
4	4	40	12	1610-4-12	2630-4-12
5	5	50	10	1610-5-10	2630-5-10
5	5	54	15	1610-5-15	2630-5-15
6	6	50	12	1610-6-12	2630-6-12
6	6	57	18	1610-6-18	2630-6-18
8	8	58	16	1610-8-16	2630-8-16
8	8	63	24	1610-8-24	2630-8-24
10	10	72	30	-	2630-10-30
12	12	83	36	-	2630-12-36

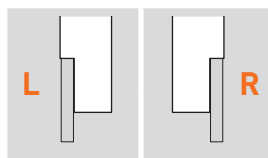
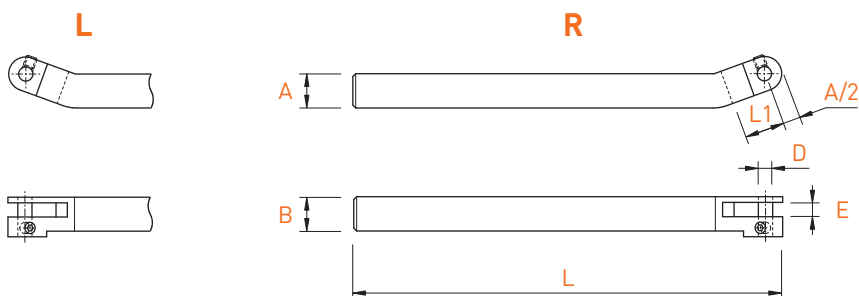

Pièces de rechange  
Ersatzteile  
Spare parts



A x B	L	E	D	L1	A/2	Art. N°	Art. N°	Art. N°
6 x 6	132	2	3	10	3	1402-623	2402-623	GP-3X10-A6H2.5
6 x 6	132	3	3	10	3	1402-633	2402-633	GP-3X10-A6H2.5
7 x 7	140	2	3	10	3.5	1402-723	2402-723	GP-3X12-A6H2.5
7 x 7	140	3	3	10	3.5	1402-733	2402-733	GP-3X12-A6H2.5
7 x 7	140	4	3	10	3.5	1402-743	2402-743	GP-3X12-A6H2.5
7 x 7	140	2	4	10	3.5	1402-724	2402-724	GP-4X12-A6H3.5
7 x 7	140	3	4	10	3.5	1402-734	2402-734	GP-4X12-A6H3.5
7 x 7	140	4	4	10	3.5	1402-744	2402-744	GP-4X12-A6H3.5
8 x 8	140	2	3	10	4	1402-823	2402-823	GP-3X12-A6H2.5
8 x 8	140	3	3	10	4	1402-833	2402-833	GP-3X12-A6H2.5
8 x 8	140	4	3	10	4	1402-843	2402-843	GP-3X12-A6H2.5
8 x 8	140	2	4	10	4	1402-824	2402-824	GP-4X12-A6H3.5
8 x 8	140	3	4	10	4	1402-834	2402-834	GP-4X12-A6H3.5
8 x 8	140	4	4	10	4	1402-844	2402-844	GP-4X12-A6H3.5
10 x 10	150	3	3	10	5	1402-1033	2402-1033	GP-3X14-A8H2.5
10 x 10	150	4	3	10	5	1402-1043	2402-1043	GP-3X14-A8H2.5
10 x 10	150	3	4	10	5	1402-1034	2402-1034	GP-4X14-A8H3.5
10 x 10	150	4	4	10	5	1402-1044	2402-1044	GP-4X14-A8H3.5
10 x 10	150	5	4	10	5	1402-1054	-	GP-4X14-A8H3.5
12 x 12	150	4	4	12	6	1402-1244	2402-1244	GP-4X14-A8H3.5
12 x 12	150	5	4	12	6	1402-1254	2402-1254	GP-4X14-A8H3.5
12 x 12	150	4	5	12	6	1402-1245	2402-1245	GP-5X14-A8H4.5
12 x 12	150	5	5	12	6	1402-1255	2402-1255	GP-5X14-A8H4.5
16 x 16	150	4	4	12	8	1402-1644	2402-1644	GP-4X16-A8H3.5
16 x 16	150	4	5	12	8	-	2402-1645	GP-5X16-A9H4.5
16 x 16	150	5	5	12	8	-	2402-1655	GP-5X16-A9H4.5
16 x 16	150	6	4	12	8	-	2402-1664	GP-4X16-A8H3.5
16 x 16	150	6	6	12	8	-	2402-1666	GP-6X16-A9H5.5
16 x 16	150	8	6	12	8	-	2402-1686	GP-6X16-A9H5.5

Molettes en métal dur

Vollhartmetall Rändelrädchen

Solid carbide knurling wheels

1107

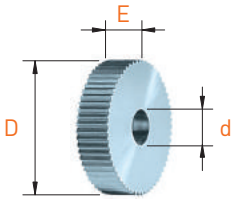

AA



BL

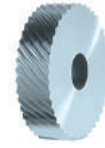

BR

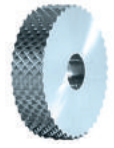

GE

Molettes standards Standard Rändelrädchen Standard knurls	D	E	d	Pas (tous les 0.1 mm) Teilung (alle 0.1 mm) Pitch (every 0.1 mm)	
AA (0°)	8	2	3	0.2 - 0.6	
	8	2	4	0.2 - 0.6	
	8	3	3	0.2 - 0.6	
	8	3	4	0.2 - 0.6	
	8	4	3	0.2 - 0.6	
	8	4	4	0.2 - 0.6	
	10	2	3	0.2 - 0.8	
	10	2	4	0.2 - 0.8	
	10	3	3	0.2 - 0.8	
	BL 15° / BR 15° BL 30° / BR 30° BL 45° / BR 45°	10	3	4	0.2 - 0.8
		10	4	3	0.2 - 0.8
		10	4	4	0.2 - 0.8
		10	4	4	0.2 - 0.8
	GE 30° GE 45°	12	4	4	0.3 - 1.0
		15	4	4	0.4 - 1.0
		15	4	5	0.4 - 1.0
		15	5	4	0.4 - 1.0
		15	5	5	0.4 - 1.0
		20	4	5	0.5 - 1.2
20		5	5	0.5 - 1.2	
20		6	6	0.5 - 1.2	
20	8	6	0.5 - 1.2		

Molettes "Quick" "Quick"-Rändelrädchen "Quick"-knurling wheels	D	E	d	Pas (tous les 0.1 mm) Teilung (alle 0.1 mm) Pitch (every 0.1 mm)
AA (0°)	8.9	2.5	4	0.2 - 0.8
BL 15° / BR 15°	14.5	3	5	0.4 - 1.0
BL 30° / BR 30°	21.5	5	8	0.5 - 1.2

Exécutions spéciales sur demande  
Sonderausführungen auf Anfrage  
Special executions on request

MICRO-LINE

APPLITEC





## Index

Nuances  
Sorten  
Grades > 14.02

Micro-fraises de précision  
Mikropräzisionsfräser  
Precision micro end mills



> 14.04

Fraises en bout de finition  
Schlicht Schaftfräser  
Finishing end mills



> 14.51

Fraises à graver  
Gravierfräser  
Engraving mills

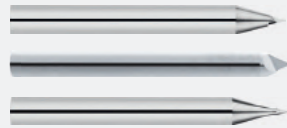

> 14.98

Micro-forets et centreurs  
Mikrobohrer und Zentrierbohrer  
Micro drills and centering drills



> 14.104

Informations techniques et symboles  
Technische Informationen und Symbole  
Technical information and symbols

> 14.126

Nuances

Sorten

Grades

**new**

## N

Non revêtu  
Unbeschichtet  
Uncoated

- Carbures de haute qualité et spécifiques selon les groupes produits
- Tous les carbures ont une excellente dureté et résistance à la flexion exceptionnelle
- Acuité d'arête maximale grâce à une finition super polie
- Idéal pour l'usinage en super finition de matières non ferreuses ou faiblement alliées

- Hochqualität und spezifische Hartmetalle gemäß den Produktgruppen
- Alle Hartmetalle haben eine ausgezeichnete Härte und außergewöhnliche Biegefestigkeit
- Maximale Kantenschärfe durch hochpoliertes Finish
- Ideal für superfinish Bearbeitung von Nichteisen- oder niedriglegierten Materialien

- High quality and specific carbides according to the product groups in our catalog
- All carbides have excellent hardness and exceptional flexural strength
- Maximum edge sharpness thanks to a super polished tool finish
- Ideal for super-finish machining of non-ferrous or low-alloy materials

## TiAlN

Revêtement PDV à couche mince  
Dünnschicht PVD Beschichtung  
Thin PVD coating

- Revêtement de dernière génération couche mince et lisse
- Idéal pour tous les aciers et aciers inoxydables
- Bonne condition pour les grades de titane et alliage de nickel
- Excellente variante universelle pour un fraisage en finition ou ébauche
- Très bonne résistance à la température

- Neuesten Generation Beschichtung, dünne und glatte Schicht
- Hervorragend für alle Stähle und rostfreie Stähle
- Guter Zustand für Titan- und Nickellegierungsorten
- Ausgezeichnete Universalsorte zum Schlicht- oder Schruppfräsen
- Sehr gute Temperaturbeständigkeit

- Latest generation coating thin and smooth layer
- Specially adapted for our tools Ideal for all basic steels and stainless steels
- Good condition for Titan grades and Nickel alloy
- Excellent universal variant for finishing or rough milling
- Very good temperature resistance

## STF

Revêtement PDV à couche mince  
Dünnschicht PVD Beschichtung  
Thin PVD coating

- Revêtement haute performance
- Premier choix pour les alliages de chrome/nickel, inox, titane, zirkonium
- Spécialement adapté aux matières extrêmes en générale

- Hochleistungsbeschichtung
- Erste Wahl für Chrom/ Nickel, rostfreier Stahl, Titan, Zirkoniumlegierungen
- Speziell angepasst für extreme Materialien im Allgemeinen

- High performance coating
- First choice for chrome/nickel, stainless steel, titan, zirkonium alloys
- Specially adapted to extreme materials in general

Nuances

Sorten

Grades

**TiCN**

Revêtement PDV à couche mince  
Dünnschicht PVD Beschichtung  
Thin PVD coating

- Revêtement de dernière génération, excellente adhérence couche mince et lisse
- Idéal pour le fraisage en finition de tous les aciers et aciers inoxydables
- Excellente nuance pour les outils de petits diamètres (0.02-0.90 mm)

- Neuesten Generation Beschichtung, dünne und glatte Schicht
- Hervorragend für Schlichtfräsen aller Stähle und rostfreien Stähle
- Ausgezeichnete Sorte für Werkzeuge mit kleinem Durchmesser (0.02-0.90 mm)

- Latest generation coating excellent adhesion thin and smooth layer
- Specially adapted for small diameters (0.02-0.90 mm)
- Ideal for finish milling for all steels and stainless steel

**DLC**

Revêtement DLC à couche mince  
Dünnschicht DLC Beschichtung  
Thin DLC coating





- Revêtement très haute performance couche extra mince
- Très faible coefficient de frottement
- Premier choix pour toutes les matières précieuses, non ferreuse et abrasives, telles que or, argent, laiton sans plomb, cuivre, aluminium, fibre de carbone, nacre et divers polymères...
- Angles de coupe parfaitement lisses et excellente acuité d'arrête
- Durée de vie de l'outil démultipliée

- Extra Dünnschicht Hochleistungsbeschichtung
- Sehr geringer Reibwert
- Erste Wahl für alle edlen, NE- und abrasiven Materialien wie Gold, Silber, bleifreies Messing, Kupfer, Aluminium, Kohlefaser, Perlmutter und diverse Polymere...
- Perfekt glatte Schnittwinkel und hervorragende Kantenschärfe
- Erhöhte Lebensdauer des Werkzeugs

- Very high-performance coating extra thin layer
- Very low ratio
- First choice for all precious, non-ferrous and abrasive materials, such as gold, silver, lead-free brass, copper, aluminum, carbon fiber, mother-of-pearl and various polymers...
- Perfectly smooth cutting angles and excellent edge sharpness
- Increased tool life

Paramètres de coupe indicatif  
Empfohlene Schnittwerte  
Standard machining data

14.06

 Sharp Corner  Radius Corner	Micro-fraises avec angles vifs Mikropräzisionsfräser mit scharfkantigen Ecken Micro end mills with sharp corners							
	Z	$\lambda$	L2	D1	D2	Type	page	
	Z=1	0°	2x D1	00.20 - 3.00	03h4 / 04h5	3170-2	14.07	
			2x D1	00.20 - 3.00	03h4 / 04h5	3170R-2	14.08	
			3x D1	00.20 - 3.00	03h4 / 04h5	3170R-3	14.09	
			4x D1	00.30 - 3.00	03h4 / 04h5	3170R-4	14.10	
	Z=2	30°	0.75x D1	00.20 - 2.00	03h4	3271-0.75	14.11	
			1x D1	00.30 - 2.50	03h4	3271-1	14.12	
			1.5x D1	00.10 - 2.00	03h4	3271-1.5	14.13	
			2x D1	00.10 - 2.00	03h4	3271-2	14.14	
			3x D1	00.10 - 2.90	03h4	3271-3	14.15	
			5x D1	00.30 - 2.50	03h4	3271-5	14.16	
			8x D1	00.40 - 2.50	03h4 / 04h5	3271-8	14.17	
			2x D1	00.20 - 3.00	03h4 / 06h5	3270S-3X	14.18 <b>new</b>	
			2x D1	00.30 - 3.00	03h4 / 06h5	3270S-6X	14.19 <b>new</b>	
			2x D1	00.40 - 3.00	03h4 / 06h5	3270S-9X	14.20 <b>new</b>	
			2x D1	00.30 - 3.00	03h4 / 06h5	3279T-3X	14.21 <b>new</b>	
			2x D1	00.30 - 3.00	03h4 / 06h5	3279T-6X	14.22 <b>new</b>	
2x D1	00.40 - 3.00	03h4 / 06h5	3279T-9X	14.23 <b>new</b>				
	Z=3	30°	1.3x D1	00.30 - 2.90	03h4	3371-1.3	14.24	
			2x D1	00.30 - 2.90	03h4	3371-2	14.25	
			3x D1	00.30 - 2.90	03h4	3371-3	14.26	
			4x D1	00.30 - 2.90	03h4	3371-4	14.27	
			5x D1	00.50 - 2.50	03h4	3371-5	14.28	
			8x D1	00.50 - 2.50	03h4 / 04h5	3371-8	14.29	
		45°	2.5x D1	00.30 - 2.90	03h4	3375-2.5	14.30	
			1.5x D1	00.30 - 2.50	03h4	DHD3371-1.5	14.31	
		36°-38°-40°	3x D1	00.30 - 2.50	03h4	DHD3371-3	14.32	
			30°	2x D1	00.30 - 3.00	03h4 / 06h5	3370S-3X	14.33 <b>new</b>
				2x D1	00.30 - 3.00	03h4 / 06h5	3370S-6X	14.34 <b>new</b>
				2x D1	00.40 - 3.00	03h4 / 06h5	3370S-9X	14.35 <b>new</b>
2x D1	00.30 - 3.00			03h4 / 06h5	3379T-3X	14.36 <b>new</b>		
2x D1	00.30 - 3.00			03h4 / 06h5	3379T-6X	14.37 <b>new</b>		
2x D1	00.40 - 3.00	03h4 / 06h5		3379T-9X	14.38 <b>new</b>			
Z=4	30°	1.5x D1	00.30 - 2.90	03h4	3471-1.5	14.39		
		3x D1	00.30 - 2.90	03h4	3471-3	14.40		
		35°-38°	3x D1	00.50 - 2.50	03h4	DHP3471-3	14.41	
			2x D1	00.30 - 2.90	03h4	3472-2	14.42	
			40°	4x D1	00.40 - 2.90	03h4	3472-4	14.43

Micro-fraises de précision

Mikropräzisionsfräser

Precision micro end mills

Index

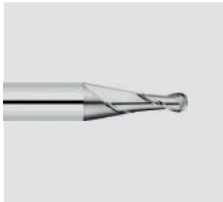
U	Micro-fraises hémisphériques Vollradius Mikropräzisionsfräser Ball nose micro end mills						
	Z	$\lambda$	L2	Range	D2	Type	page
	Z = 2	30°	0.75x D1	Ø0.20 - 2.50	Ø3h4	3278-0.75	14.44
			1x D1	Ø0.20 - 2.90	Ø3h4	3278-1	14.45
			1.5x D1	Ø0.20 - 2.90	Ø3h4	3278-1.5	14.46
			3x D1	Ø0.20 - 2.90	Ø3h4	3278-3	14.47
			1.5x D1	Ø0.20 - 3.00	Ø3h4 / Ø6h5	3278H-3X	14.48 <b>new</b>
			1.5x D1	Ø0.30 - 3.00	Ø3h4 / Ø6h5	3278H-6X	14.49 <b>new</b>
			1.5x D1	Ø0.40 - 3.00	Ø3h4 / Ø6h5	3278H-9X	14.50 <b>new</b>

Matière Werkstoff Material	VC	0.10 - 0.50	0.60 - 1.50	1.60 - 2.90	Z	TiAlN	STF	TiCN	DLC	
	(m/min)	fz (mm)	fz (mm)	fz (mm)						
Acier de décolletage Automatenstahl Free-cutting steel	P	80 - 130	0.003 - 0.005	0.006 - 0.010	0.013 - 0.020	-	***	***	**	-
Acier Stahl Steel	< 600 N/mm <sup>2</sup> P	70 - 100	0.003 - 0.005	0.006 - 0.010	0.013 - 0.020	-	***	***	**	-
Acier Stahl Steel	< 800 N/mm <sup>2</sup> P	70 - 100	0.003 - 0.005	0.006 - 0.010	0.013 - 0.020	-	***	***	**	-
Acier Stahl Steel	> 800 N/mm <sup>2</sup> P	50 - 80	0.003 - 0.005	0.006 - 0.010	0.013 - 0.020	-	***	***	**	-
Acier trempé Gehärteter Stahl -55HRC Hardened steel	H	60 - 90	0.001 - 0.002	0.003 - 0.005	0.007 - 0.010	-	***	***	*	-
Acier trempé Gehärteter Stahl +55HRC Hardened steel	H	40 - 70	0.001 - 0.002	0.003 - 0.005	0.007 - 0.010	-	***	***	*	-
Inox Rostfreistahl Stainless steel	M	40 - 80	0.003 - 0.005	0.006 - 0.010	0.013 - 0.020	-	***	***	**	-
Aluminium	N	200 - 300	0.002 - 0.005	0.005 - 0.010	0.010 - 0.030	***	-	-	**	***
Cuivre, laiton, bronze Kupfer, Messing, Bronze Copper, brass, bronze	N	100 - 200	0.001 - 0.005	0.006 - 0.010	0.010 - 0.015	***	**	**	**	***
Matière synthétique Synthetisches Material Synthetic material	N	200 - 700	0.002 - 0.004	0.006 - 0.015	0.015 - 0.050	***	**	**	**	***
Métaux précieux Edelmetalle Precious metals	N	90 - 140	0.002 - 0.003	0.004 - 0.012	0.012 - 0.025	***	**	**	*	***
Titane Titan Titanium	S	25 - 70	0.001 - 0.003	0.004 - 0.010	0.006 - 0.015	-	***	***	**	-
Alliage de nickel Nickel-Legierung Nickel alloy	S	40 - 70	0.001 - 0.003	0.004 - 0.008	0.008 - 0.012	-	***	***	**	-
Matière exotique Exotisches material Exotic material	O	15 - 25	0.001 - 0.002	0.003 - 0.005	0.006 - 0.010	-	***	***	**	***

Avec revêtement, augmenter les valeurs de 20-30%  
Mit Beschichtung, Daten um 20-30% erhöhen  
With coating, increase data by 20-30%

\* Bien / Gut / Good  
\*\* Très bien / Sehr Gut / Very good  
\*\*\* Excellent / Ausgezeichnet / Excellent

Micro-fraises de précision

Mikropräzisionsfräser

Precision micro end mills

3170-2

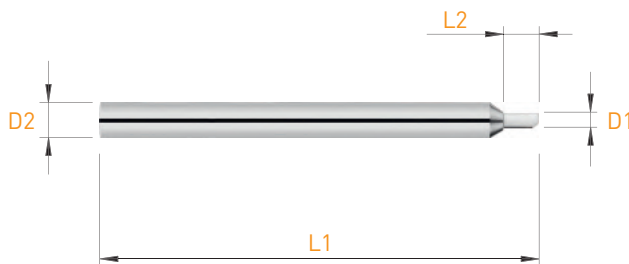

D1 +0.005 / -0.010	L2	D2 h4 03.0 h5 04.0	L1	Art. N°	Z	TiAlN	STF	TiCN	DLC
0.20	0.40	3.00	39	3170-2-0.20	■				
0.30	0.60	3.00	39	3170-2-0.30	■	■	■	■	■
0.40	0.80	3.00	39	3170-2-0.40	■	■	■	■	■
0.50	1.00	3.00	39	3170-2-0.50	■	■	■	■	■
0.60	1.20	3.00	39	3170-2-0.60	■	■	■	■	■
0.70	1.40	3.00	39	3170-2-0.70	■	■	■	■	■
0.80	1.60	3.00	39	3170-2-0.80	■	■	■	■	■
0.90	1.80	3.00	39	3170-2-0.90	■	■	■	■	■
1.00	2.00	3.00	39	3170-2-1.00	■	■	■	■	■
1.10	2.20	3.00	39	3170-2-1.10	■	■	■	■	■
1.20	2.40	3.00	39	3170-2-1.20	■	■	■	■	■
1.30	2.60	3.00	39	3170-2-1.30	■	■	■	■	■
1.40	2.80	3.00	39	3170-2-1.40	■	■	■	■	■
1.50	3.00	3.00	39	3170-2-1.50	■	■	■	■	■
1.60	3.20	3.00	39	3170-2-1.60	■	■	■	■	■
1.70	3.40	3.00	39	3170-2-1.70	■	■	■	■	■
1.80	3.60	3.00	39	3170-2-1.80	■	■	■	■	■
1.90	3.80	3.00	39	3170-2-1.90	■	■	■	■	■
2.00	4.00	3.00	39	3170-2-2.00	■	■	■	■	■
2.10	4.20	3.00	39	3170-2-2.10	■	■	■	■	■
2.20	4.40	3.00	39	3170-2-2.20	■	■	■	■	■
2.30	4.60	3.00	39	3170-2-2.30	■	■	■	■	■
2.40	4.80	3.00	39	3170-2-2.40	■	■	■	■	■
2.50	5.00	3.00	39	3170-2-2.50	■	■	■	■	■
2.60	5.20	3.00	39	3170-2-2.60	■	■	■	■	■
2.70	5.40	3.00	39	3170-2-2.70	■	■	■	■	■
2.80	5.60	3.00	39	3170-2-2.80	■	■	■	■	■
2.90	5.80	3.00	39	3170-2-2.90	■	■	■	■	■
3.00	6.00	4.00	40	3170-2-3.00	■	■	■	■	■

# MICRO-LINE

Micro-fraises de précision

Mikropräzisionsfräser

Precision micro end mills

## 3170R-2

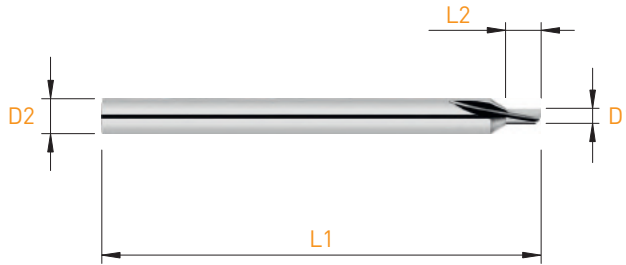

D1 +0.005 / -0.010	L2	D2 h4 Ø3.0 h5 Ø4.0	L1	Art. N°	Z	TiAlN	STF	TiCN	DLC
0.20	0.40	3.00	39	3170R-2-0.20	■				
0.30	0.60	3.00	39	3170R-2-0.30	■	■	■	■	■
0.40	0.80	3.00	39	3170R-2-0.40	■	■	■	■	■
0.50	1.00	3.00	39	3170R-2-0.50	■	■	■	■	■
0.60	1.20	3.00	39	3170R-2-0.60	■	■	■	■	■
0.70	1.40	3.00	39	3170R-2-0.70	■	■	■	■	■
0.80	1.60	3.00	39	3170R-2-0.80	■	■	■	■	■
0.90	1.80	3.00	39	3170R-2-0.90	■	■	■	■	■
1.00	2.00	3.00	39	3170R-2-1.00	■	■	■	■	■
1.10	2.20	3.00	39	3170R-2-1.10	■	■	■	■	■
1.20	2.40	3.00	39	3170R-2-1.20	■	■	■	■	■
1.30	2.60	3.00	39	3170R-2-1.30	■	■	■	■	■
1.40	2.80	3.00	39	3170R-2-1.40	■	■	■	■	■
1.50	3.00	3.00	39	3170R-2-1.50	■	■	■	■	■
1.60	3.20	3.00	39	3170R-2-1.60	■	■	■	■	■
1.70	3.40	3.00	39	3170R-2-1.70	■	■	■	■	■
1.80	3.60	3.00	39	3170R-2-1.80	■	■	■	■	■
1.90	3.80	3.00	39	3170R-2-1.90	■	■	■	■	■
2.00	4.00	3.00	39	3170R-2-2.00	■	■	■	■	■
2.10	4.10	3.00	39	3170R-2-2.10	■	■	■	■	■
2.20	4.40	3.00	39	3170R-2-2.20	■	■	■	■	■
2.30	4.60	3.00	39	3170R-2-2.30	■	■	■	■	■
2.40	4.80	3.00	39	3170R-2-2.40	■	■	■	■	■
2.50	5.00	3.00	39	3170R-2-2.50	■	■	■	■	■
2.60	5.20	3.00	39	3170R-2-2.60	■	■	■	■	■
2.70	5.40	3.00	39	3170R-2-2.70	■	■	■	■	■
2.80	5.60	3.00	39	3170R-2-2.80	■	■	■	■	■
2.90	5.80	3.00	39	3170R-2-2.90	■	■	■	■	■
3.00	6.00	4.00	40	3170R-2-3.00	■	■	■	■	■



Micro-fraises de précision

Mikropräzisionsfräser

Precision micro end mills

3170R-3

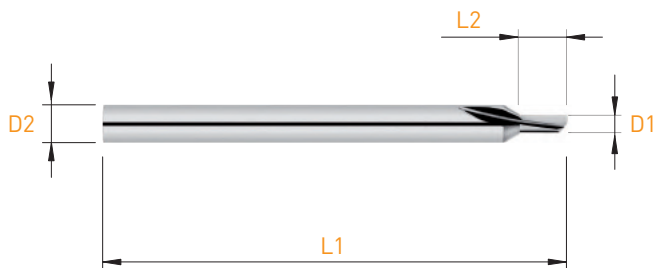

D1 +0.005 / -0.010	L2	D2 h4 Ø3.0 h5 Ø4.0	L1	Art. N°	Z	TiAlN	STF	TiCN	DLC
0.20	0.60	3.00	39	3170R-3-0.20	■				
0.30	0.90	3.00	39	3170R-3-0.30	■	■	■	■	■
0.40	1.20	3.00	39	3170R-3-0.40	■	■	■	■	■
0.50	1.50	3.00	39	3170R-3-0.50	■	■	■	■	■
0.60	1.80	3.00	39	3170R-3-0.60	■	■	■	■	■
0.70	2.10	3.00	39	3170R-3-0.70	■	■	■	■	■
0.80	2.40	3.00	39	3170R-3-0.80	■	■	■	■	■
0.90	2.70	3.00	39	3170R-3-0.90	■	■	■	■	■
1.00	3.00	3.00	39	3170R-3-1.00	■	■	■	■	■
1.10	3.30	3.00	39	3170R-3-1.10	■	■	■	■	■
1.20	3.60	3.00	39	3170R-3-1.20	■	■	■	■	■
1.30	3.90	3.00	39	3170R-3-1.30	■	■	■	■	■
1.40	4.20	3.00	39	3170R-3-1.40	■	■	■	■	■
1.50	4.50	3.00	39	3170R-3-1.50	■	■	■	■	■
2.00	6.00	3.00	39	3170R-3-2.00	■	■	■	■	■
2.50	7.50	3.00	39	3170R-3-2.50	■	■	■	■	■
3.00	9.00	4.00	40	3170R-3-3.00	■	■	■	■	■

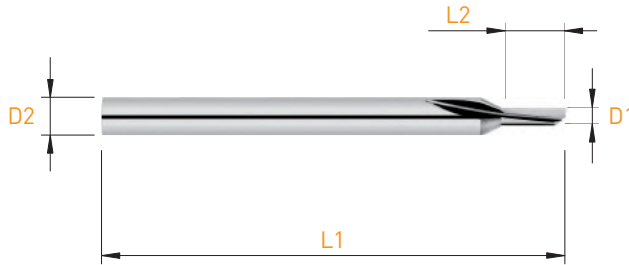

D1 +0.005 / -0.010	L2	D2 h4 03.0 h5 04.0	L1	Art. N°	Z	TiAlN	STF	TiCN	DLC
0.30	1.20	3.00	39	3170R-4-0.30	■	■	■	■	■
0.40	1.60	3.00	39	3170R-4-0.40	■	■	■	■	■
0.50	2.00	3.00	39	3170R-4-0.50	■	■	■	■	■
0.60	2.40	3.00	39	3170R-4-0.60	■	■	■	■	■
0.70	2.80	3.00	39	3170R-4-0.70	■	■	■	■	■
0.80	3.20	3.00	39	3170R-4-0.80	■	■	■	■	■
0.90	3.60	3.00	39	3170R-4-0.90	■	■	■	■	■
1.00	4.00	3.00	39	3170R-4-1.00	■	■	■	■	■
1.10	4.40	3.00	39	3170R-4-1.10	■	■	■	■	■
1.20	4.80	3.00	39	3170R-4-1.20	■	■	■	■	■
1.30	5.20	3.00	39	3170R-4-1.30	■	■	■	■	■
1.40	5.60	3.00	39	3170R-4-1.40	■	■	■	■	■
1.50	6.00	3.00	39	3170R-4-1.50	■	■	■	■	■
2.00	8.00	3.00	39	3170R-4-2.00	■	■	■	■	■
2.50	10.00	3.00	39	3170R-4-2.50	■	■	■	■	■
3.00	12.00	4.00	40	3170R-4-3.00	■	■	■	■	■

Micro-fraises de précision

Mikropräzisionsfräser

Precision micro end mills

3271-0.75

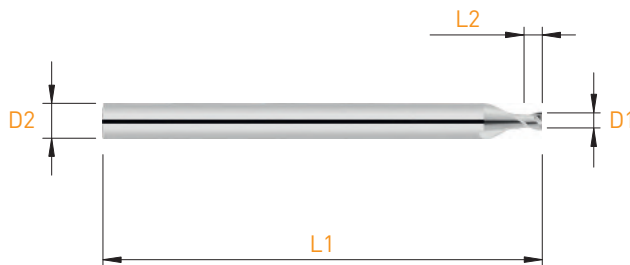

D1 +0.005 / -0.010	L2	D2 h4	L1	Art. N°	Z	TiAlN	STF	TiCN	DLC
0.20	0.15	3.00	39	3271-0.75-0.20	■				
0.30	0.25	3.00	39	3271-0.75-0.30	■	■	■	■	■
0.40	0.30	3.00	39	3271-0.75-0.40	■	■	■	■	■
0.50	0.37	3.00	39	3271-0.75-0.50	■	■	■	■	■
0.60	0.45	3.00	39	3271-0.75-0.60	■	■	■	■	■
0.70	0.53	3.00	39	3271-0.75-0.70	■	■	■	■	■
0.80	0.60	3.00	39	3271-0.75-0.80	■	■	■	■	■
0.90	0.70	3.00	39	3271-0.75-0.90	■	■	■	■	■
1.00	0.75	3.00	39	3271-0.75-1.00	■	■	■	■	■
1.10	0.90	3.00	39	3271-0.75-1.10	■	■	■	■	■
1.20	0.90	3.00	39	3271-0.75-1.20	■	■	■	■	■
1.30	1.00	3.00	39	3271-0.75-1.30	■	■	■	■	■
1.40	1.10	3.00	39	3271-0.75-1.40	■	■	■	■	■
1.50	1.15	3.00	39	3271-0.75-1.50	■	■	■	■	■
1.60	1.20	3.00	39	3271-0.75-1.60	■	■	■	■	■
1.70	1.30	3.00	39	3271-0.75-1.70	■	■	■	■	■
1.80	1.40	3.00	39	3271-0.75-1.80	■	■	■	■	■
1.90	1.45	3.00	39	3271-0.75-1.90	■	■	■	■	■
2.00	1.50	3.00	39	3271-0.75-2.00	■	■	■	■	■

# MICRO-LINE

Micro-fraises de précision

Mikropräzisionsfräser

Precision micro end mills

## 3271-1

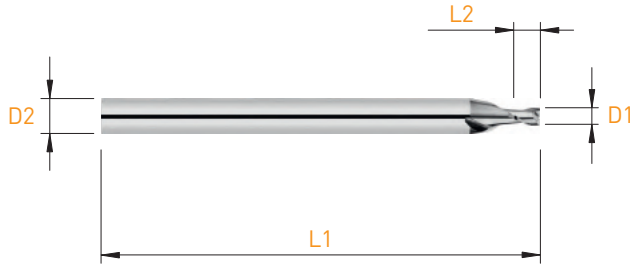

D1 +0.005 / -0.010	L2	D2 h4	L1	Art. N°	Z	TiAlN	STF	TiCN	DLC
0.30	0.30	3.00	39	3271-1-0.30	■	■	■	■	■
0.40	0.40	3.00	39	3271-1-0.40	■	■	■	■	■
0.50	0.50	3.00	39	3271-1-0.50	■	■	■	■	■
0.60	0.60	3.00	39	3271-1-0.60	■	■	■	■	■
0.70	0.70	3.00	39	3271-1-0.70	■	■	■	■	■
0.80	0.80	3.00	39	3271-1-0.80	■	■	■	■	■
0.90	0.90	3.00	39	3271-1-0.90	■	■	■	■	■
1.00	1.00	3.00	39	3271-1-1.00	■	■	■	■	■
1.10	1.10	3.00	39	3271-1-1.10	■	■	■	■	■
1.20	1.20	3.00	39	3271-1-1.20	■	■	■	■	■
1.30	1.30	3.00	39	3271-1-1.30	■	■	■	■	■
1.40	1.40	3.00	39	3271-1-1.40	■	■	■	■	■
1.50	1.50	3.00	39	3271-1-1.50	■	■	■	■	■
1.60	1.60	3.00	39	3271-1-1.60	■	■	■	■	■
1.70	1.70	3.00	39	3271-1-1.70	■	■	■	■	■
1.80	1.80	3.00	39	3271-1-1.80	■	■	■	■	■
1.90	1.90	3.00	39	3271-1-1.90	■	■	■	■	■
2.00	2.00	3.00	39	3271-1-2.00	■	■	■	■	■
2.50	2.50	3.00	39	3271-1-2.50	■	■	■	■	■

Micro-fraises de précision

Mikropräzisionsfräser

Precision micro end mills

3271-1.5

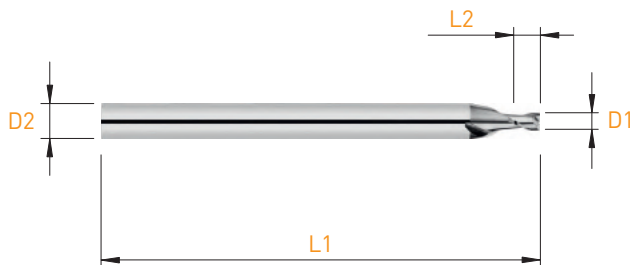

D1 +0.005 / -0.010	L2	D2 h4	L1	Art. N°	Z	TiAlN	STF	TiCN	DLC
0.10	0.15	3.00	39	3271-1.5-0.10	■				
0.15	0.20	3.00	39	3271-1.5-0.15	■				
0.20	0.30	3.00	39	3271-1.5-0.20	■				
0.25	0.35	3.00	39	3271-1.5-0.25	■				
0.30	0.45	3.00	39	3271-1.5-0.30	■	■	■	■	■
0.40	0.60	3.00	39	3271-1.5-0.40	■	■	■	■	■
0.45	0.70	3.00	39	3271-1.5-0.45	■	■	■	■	■
0.50	0.75	3.00	39	3271-1.5-0.50	■	■	■	■	■
0.60	0.90	3.00	39	3271-1.5-0.60	■	■	■	■	■
0.70	1.05	3.00	39	3271-1.5-0.70	■	■	■	■	■
0.80	1.20	3.00	39	3271-1.5-0.80	■	■	■	■	■
0.90	1.35	3.00	39	3271-1.5-0.90	■	■	■	■	■
1.00	1.50	3.00	39	3271-1.5-1.00	■	■	■	■	■
1.10	1.65	3.00	39	3271-1.5-1.10	■	■	■	■	■
1.20	1.80	3.00	39	3271-1.5-1.20	■	■	■	■	■
1.30	1.95	3.00	39	3271-1.5-1.30	■	■	■	■	■
1.40	2.10	3.00	39	3271-1.5-1.40	■	■	■	■	■
1.50	2.25	3.00	39	3271-1.5-1.50	■	■	■	■	■
1.60	2.40	3.00	39	3271-1.5-1.60	■	■	■	■	■
1.70	2.55	3.00	39	3271-1.5-1.70	■	■	■	■	■
1.80	2.70	3.00	39	3271-1.5-1.80	■	■	■	■	■
1.90	2.85	3.00	39	3271-1.5-1.90	■	■	■	■	■
2.00	3.00	3.00	39	3271-1.5-2.00	■	■	■	■	■

# MICRO-LINE

Micro-fraises de précision

Mikropräzisionsfräser

Precision micro end mills

3271-2

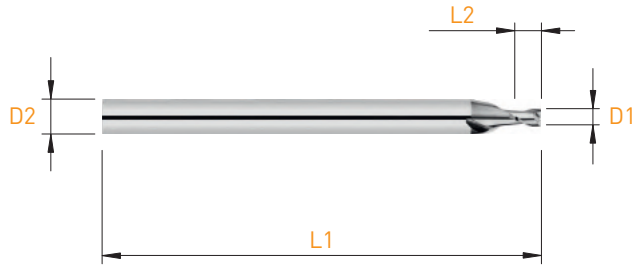

D1 +0.005 / -0.010	L2	D2 h4	L1	Art. N°	Z	TiAlN	STF	TiCN	DLC
0.10	0.20	3.00	39	3271-2-0.10	■				
0.15	0.30	3.00	39	3271-2-0.15	■				
0.20	0.40	3.00	39	3271-2-0.20	■				
0.25	0.50	3.00	39	3271-2-0.25	■				
0.30	0.60	3.00	39	3271-2-0.30	■	■	■	■	■
0.40	0.80	3.00	39	3271-2-0.40	■	■	■	■	■
0.50	1.00	3.00	39	3271-2-0.50	■	■	■	■	■
0.60	1.20	3.00	39	3271-2-0.60	■	■	■	■	■
0.70	1.40	3.00	39	3271-2-0.70	■	■	■	■	■
0.80	1.60	3.00	39	3271-2-0.80	■	■	■	■	■
0.90	1.80	3.00	39	3271-2-0.90	■	■	■	■	■
1.00	2.00	3.00	39	3271-2-1.00	■	■	■	■	■
1.10	2.20	3.00	39	3271-2-1.10	■	■	■	■	■
1.20	2.40	3.00	39	3271-2-1.20	■	■	■	■	■
1.30	2.60	3.00	39	3271-2-1.30	■	■	■	■	■
1.40	2.80	3.00	39	3271-2-1.40	■	■	■	■	■
1.50	3.00	3.00	39	3271-2-1.50	■	■	■	■	■
1.60	3.20	3.00	39	3271-2-1.60	■	■	■	■	■
1.70	3.40	3.00	39	3271-2-1.70	■	■	■	■	■
1.80	3.60	3.00	39	3271-2-1.80	■	■	■	■	■
1.90	3.80	3.00	39	3271-2-1.90	■	■	■	■	■
2.00	4.00	3.00	39	3271-2-2.00	■	■	■	■	■

Micro-fraises de précision

Mikropräzisionsfräser

Precision micro end mills

3271-3

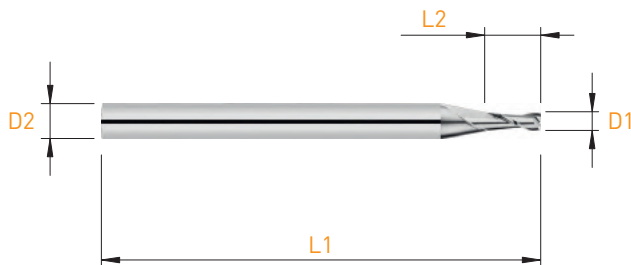

MD VHM HM  $\lambda$  30° Sharp Corner  3xD1 Z=2 

D1 +0.005 / -0.010	L2	D2 h4	L1	Art. N°	Z	TiAIN	STF	TiCN	DLC
0.10	0.25	3.00	39	3271-3-0.10	■				
0.15	0.45	3.00	39	3271-3-0.15	■				
0.20	0.50	3.00	39	3271-3-0.20	■				
0.25	0.75	3.00	39	3271-3-0.25	■				
0.30	1.00	3.00	39	3271-3-0.30	■	■	■	■	■
0.35	1.10	3.00	39	3271-3-0.35	■	■	■	■	■
0.40	1.20	3.00	39	3271-3-0.40	■	■	■	■	■
0.50	1.50	3.00	39	3271-3-0.50	■	■	■	■	■
0.60	2.00	3.00	39	3271-3-0.60	■	■	■	■	■
0.65	2.00	3.00	39	3271-3-0.65	■	■	■	■	■
0.70	2.00	3.00	39	3271-3-0.70	■	■	■	■	■
0.75	2.00	3.00	39	3271-3-0.75	■	■	■	■	■
0.80	2.50	3.00	39	3271-3-0.80	■	■	■	■	■
0.90	2.50	3.00	39	3271-3-0.90	■	■	■	■	■
0.95	3.00	3.00	39	3271-3-0.95	■	■	■	■	■
1.00	3.00	3.00	39	3271-3-1.00	■	■	■	■	■
1.05	3.00	3.00	39	3271-3-1.05	■	■	■	■	■
1.10	3.00	3.00	39	3271-3-1.10	■	■	■	■	■
1.15	3.50	3.00	39	3271-3-1.15	■	■	■	■	■
1.20	4.00	3.00	39	3271-3-1.20	■	■	■	■	■
1.30	4.00	3.00	39	3271-3-1.30	■	■	■	■	■
1.35	4.00	3.00	39	3271-3-1.35	■	■	■	■	■
1.40	4.00	3.00	39	3271-3-1.40	■	■	■	■	■
1.45	4.40	3.00	39	3271-3-1.45	■	■	■	■	■
1.50	4.50	3.00	39	3271-3-1.50	■	■	■	■	■
1.55	4.50	3.00	39	3271-3-1.55	■	■	■	■	■
1.60	4.50	3.00	39	3271-3-1.60	■	■	■	■	■
1.65	5.00	3.00	39	3271-3-1.65	■	■	■	■	■
1.70	5.00	3.00	39	3271-3-1.70	■	■	■	■	■
1.75	5.30	3.00	39	3271-3-1.75	■	■	■	■	■

D1 +0.005 / -0.010	L2	D2 h4	L1	Art. N°	Z	TiAIN	STF	TiCN	DLC
1.80	6.00	3.00	39	3271-3-1.80	■	■	■	■	■
1.85	6.00	3.00	39	3271-3-1.85	■	■	■	■	■
1.90	6.00	3.00	39	3271-3-1.90	■	■	■	■	■
1.95	6.00	3.00	39	3271-3-1.95	■	■	■	■	■
2.00	6.00	3.00	39	3271-3-2.00	■	■	■	■	■
2.10	6.00	3.00	39	3271-3-2.10	■	■	■	■	■
2.20	6.50	3.00	39	3271-3-2.20	■	■	■	■	■
2.30	7.00	3.00	39	3271-3-2.30	■	■	■	■	■
2.40	7.00	3.00	39	3271-3-2.40	■	■	■	■	■
2.50	7.50	3.00	39	3271-3-2.50	■	■	■	■	■
2.60	7.50	3.00	39	3271-3-2.60	■	■	■	■	■
2.70	8.00	3.00	39	3271-3-2.70	■	■	■	■	■
2.80	8.00	3.00	39	3271-3-2.80	■	■	■	■	■
2.90	8.00	3.00	39	3271-3-2.90	■	■	■	■	■

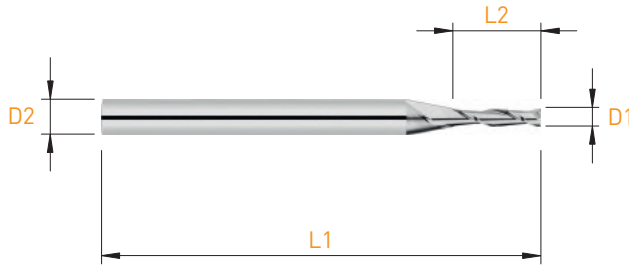

D1 +0.005 / -0.010	L2	D2 h4	L1	Art. N°	Z	TiAlN	STF	TiCN	DLC
0.30	1.50	3.00	39	3271-5-0.30	■	■	■	■	■
0.35	1.80	3.00	39	3271-5-0.35	■	■	■	■	■
0.40	2.00	3.00	39	3271-5-0.40	■	■	■	■	■
0.50	2.50	3.00	39	3271-5-0.50	■	■	■	■	■
0.55	2.80	3.00	39	3271-5-0.55	■	■	■	■	■
0.60	3.00	3.00	39	3271-5-0.60	■	■	■	■	■
0.65	3.30	3.00	39	3271-5-0.65	■	■	■	■	■
0.70	3.50	3.00	39	3271-5-0.70	■	■	■	■	■
0.75	3.80	3.00	39	3271-5-0.75	■	■	■	■	■
0.80	4.00	3.00	39	3271-5-0.80	■	■	■	■	■
0.85	4.30	3.00	39	3271-5-0.85	■	■	■	■	■
0.90	4.50	3.00	39	3271-5-0.90	■	■	■	■	■
0.95	4.80	3.00	39	3271-5-0.95	■	■	■	■	■
1.00	5.00	3.00	39	3271-5-1.00	■	■	■	■	■
1.10	5.50	3.00	39	3271-5-1.10	■	■	■	■	■
1.20	6.00	3.00	39	3271-5-1.20	■	■	■	■	■
1.50	7.50	3.00	39	3271-5-1.50	■	■	■	■	■
2.00	10.00	3.00	39	3271-5-2.00	■	■	■	■	■
2.50	12.50	3.00	39	3271-5-2.50	■	■	■	■	■



Micro-fraises de précision

Mikropräzisionsfräser

Precision micro end mills

3271-8

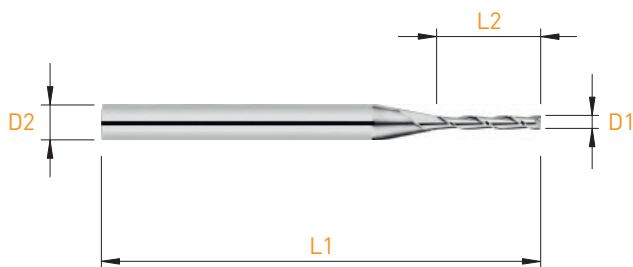

D1 +0.005 / -0.010	L2	D2 h4 03.0 h5 04.0	L1	Art. N°	Z	TiAlN	STF	TiCN	DLC
0.40	3.20	3.00	39	3271-8-0.40	■	■	■	■	■
0.50	4.00	3.00	39	3271-8-0.50	■	■	■	■	■
0.60	5.00	3.00	39	3271-8-0.60	■	■	■	■	■
0.70	5.60	3.00	39	3271-8-0.70	■	■	■	■	■
0.80	6.00	3.00	39	3271-8-0.80	■	■	■	■	■
0.90	7.20	3.00	39	3271-8-0.90	■	■	■	■	■
1.00	8.00	3.00	39	3271-8-1.00	■	■	■	■	■
1.20	9.00	3.00	39	3271-8-1.20	■	■	■	■	■
1.50	12.00	4.00	50	3271-8-1.50	■	■	■	■	■
2.00	16.00	4.00	50	3271-8-2.00	■	■	■	■	■
2.50	20.00	4.00	50	3271-8-2.50	■	■	■	■	■

# MICRO-LINE

Micro-fraises de précision

Mikropräzisionsfräser

Precision micro end mills

## 3270S-3X

**new**

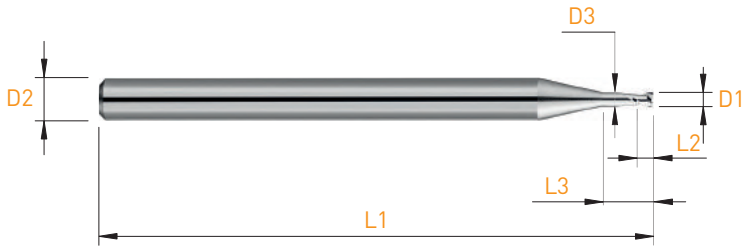

D1 +0.005 / -0.010	L2	L3	D3	D2 h4 $\emptyset 3.0$ h5 $\emptyset 6.0$	L1	Art. N°	Z	TiAIN	STF	TiCN	DLC
0.20	0.40	0.60	0.17	3.00	39	3270S-3X-0.20	■				
0.30	0.60	0.90	0.27	3.00	39	3270S-3X-0.30	■	■	■	■	■
0.40	0.80	1.20	0.37	3.00	39	3270S-3X-0.40	■	■	■	■	■
0.50	1.00	1.50	0.45	3.00	39	3270S-3X-0.50	■	■	■	■	■
0.60	1.20	1.80	0.55	3.00	39	3270S-3X-0.60	■	■	■	■	■
0.70	1.40	2.10	0.65	3.00	39	3270S-3X-0.70	■	■	■	■	■
0.80	1.60	2.40	0.75	3.00	39	3270S-3X-0.80	■	■	■	■	■
0.90	1.80	2.70	0.85	3.00	39	3270S-3X-0.90	■	■	■	■	■
1.00	2.00	3.00	0.95	3.00	39	3270S-3X-1.00	■	■	■	■	■
1.10	2.20	3.30	1.05	3.00	39	3270S-3X-1.10	■	■	■	■	■
1.20	2.40	3.60	1.15	3.00	39	3270S-3X-1.20	■	■	■	■	■
1.30	2.60	3.90	1.25	3.00	39	3270S-3X-1.30	■	■	■	■	■
1.40	2.80	4.20	1.35	3.00	39	3270S-3X-1.40	■	■	■	■	■
1.50	3.00	4.50	1.45	3.00	39	3270S-3X-1.50	■	■	■	■	■
1.60	3.20	4.80	1.55	3.00	39	3270S-3X-1.60	■	■	■	■	■
1.70	3.40	5.10	1.65	3.00	39	3270S-3X-1.70	■	■	■	■	■
1.80	3.60	5.40	1.75	3.00	39	3270S-3X-1.80	■	■	■	■	■
1.90	3.80	5.70	1.85	3.00	39	3270S-3X-1.90	■	■	■	■	■
2.00	4.00	6.00	1.95	6.00	50	3270S-3X-2.00	■	■	■	■	■
2.10	4.20	6.30	2.05	6.00	50	3270S-3X-2.10	■	■	■	■	■
2.20	4.40	6.60	2.15	6.00	50	3270S-3X-2.20	■	■	■	■	■
2.30	4.60	6.90	2.25	6.00	50	3270S-3X-2.30	■	■	■	■	■
2.40	4.80	7.20	2.35	6.00	50	3270S-3X-2.40	■	■	■	■	■
2.50	5.00	7.50	2.45	6.00	50	3270S-3X-2.50	■	■	■	■	■
3.00	6.00	9.00	2.95	6.00	50	3270S-3X-3.00	■	■	■	■	■

Micro-fraises de précision

Mikropräzisionsfräser

Precision micro end mills

3270S-6X

new

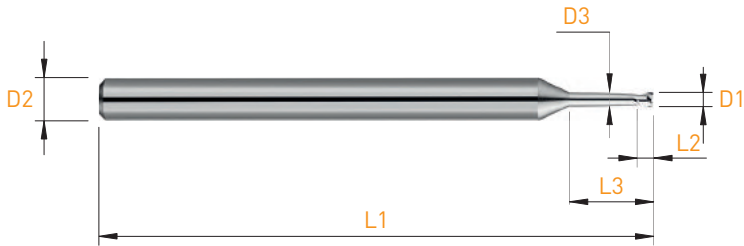

D1 +0.005 / -0.010	L2	L3	D3	D2 h4 $\varnothing 3.0$ h5 $\varnothing 6.0$	L1	Art. N°	Z	TiAIN	STF	TiCN	DLC
0.30	0.60	1.80	0.27	3.00	39	3270S-6X-0.30	■	■	■	■	■
0.40	0.80	2.40	0.37	3.00	39	3270S-6X-0.40	■	■	■	■	■
0.50	1.00	3.00	0.45	3.00	39	3270S-6X-0.50	■	■	■	■	■
0.60	1.20	3.60	0.55	3.00	39	3270S-6X-0.60	■	■	■	■	■
0.70	1.40	4.20	0.65	3.00	39	3270S-6X-0.70	■	■	■	■	■
0.80	1.60	4.80	0.75	3.00	39	3270S-6X-0.80	■	■	■	■	■
0.90	1.80	5.40	0.85	3.00	39	3270S-6X-0.90	■	■	■	■	■
1.00	2.00	6.00	0.95	3.00	39	3270S-6X-1.00	■	■	■	■	■
1.10	2.20	6.60	1.05	3.00	39	3270S-6X-1.10	■	■	■	■	■
1.20	2.40	7.20	1.15	3.00	39	3270S-6X-1.20	■	■	■	■	■
1.30	2.60	7.80	1.25	3.00	39	3270S-6X-1.30	■	■	■	■	■
1.40	2.80	8.40	1.35	3.00	39	3270S-6X-1.40	■	■	■	■	■
1.50	3.00	9.00	1.45	3.00	39	3270S-6X-1.50	■	■	■	■	■
1.60	3.20	9.60	1.55	3.00	39	3270S-6X-1.60	■	■	■	■	■
1.70	3.40	10.20	1.65	3.00	39	3270S-6X-1.70	■	■	■	■	■
1.80	3.60	10.80	1.75	3.00	39	3270S-6X-1.80	■	■	■	■	■
1.90	3.80	11.40	1.85	3.00	39	3270S-6X-1.90	■	■	■	■	■
2.00	4.00	12.00	1.95	6.00	50	3270S-6X-2.00	■	■	■	■	■
2.10	4.20	12.60	2.05	6.00	50	3270S-6X-2.10	■	■	■	■	■
2.20	4.40	13.20	2.15	6.00	50	3270S-6X-2.20	■	■	■	■	■
2.30	4.60	13.80	2.25	6.00	50	3270S-6X-2.30	■	■	■	■	■
2.40	4.80	14.40	2.35	6.00	50	3270S-6X-2.40	■	■	■	■	■
2.50	5.00	15.00	2.45	6.00	50	3270S-6X-2.50	■	■	■	■	■
3.00	6.00	18.00	2.95	6.00	50	3270S-6X-3.00	■	■	■	■	■

# MICRO-LINE

Micro-fraises de précision

Mikropräzisionsfräser

Precision micro end mills

## 3270S-9X

**new**



D1 +0.005 / -0.010	L2	L3	D3	D2 h4 $\varnothing 3.0$ h5 $\varnothing 6.0$	L1	Art. N°	Z	TiAIN	STF	TiCN	DLC
0.40	0.80	3.60	0.37	3.00	39	3270S-9X-0.40	■	■	■	■	■
0.50	1.00	4.50	0.45	3.00	39	3270S-9X-0.50	■	■	■	■	■
0.60	1.20	5.40	0.55	3.00	39	3270S-9X-0.60	■	■	■	■	■
0.70	1.40	6.30	0.65	3.00	39	3270S-9X-0.70	■	■	■	■	■
0.80	1.60	7.20	0.75	3.00	39	3270S-9X-0.80	■	■	■	■	■
0.90	1.80	8.10	0.85	3.00	39	3270S-9X-0.90	■	■	■	■	■
1.00	2.00	9.00	0.95	3.00	39	3270S-9X-1.00	■	■	■	■	■
1.10	2.20	9.90	1.05	3.00	39	3270S-9X-1.10	■	■	■	■	■
1.20	2.40	10.80	1.15	3.00	39	3270S-9X-1.20	■	■	■	■	■
1.30	2.60	11.70	1.25	3.00	39	3270S-9X-1.30	■	■	■	■	■
1.40	2.80	12.60	1.35	3.00	39	3270S-9X-1.40	■	■	■	■	■
1.50	3.00	13.50	1.45	3.00	39	3270S-9X-1.50	■	■	■	■	■
1.60	3.20	14.40	1.55	3.00	39	3270S-9X-1.60	■	■	■	■	■
1.70	3.40	15.30	1.65	3.00	39	3270S-9X-1.70	■	■	■	■	■
1.80	3.60	16.20	1.75	3.00	39	3270S-9X-1.80	■	■	■	■	■
1.90	3.80	17.10	1.85	3.00	39	3270S-9X-1.90	■	■	■	■	■
2.00	4.00	18.00	1.95	6.00	50	3270S-9X-2.00	■	■	■	■	■
2.10	4.20	18.90	2.05	6.00	50	3270S-9X-2.10	■	■	■	■	■
2.20	4.40	19.80	2.15	6.00	50	3270S-9X-2.20	■	■	■	■	■
2.30	4.60	20.70	2.25	6.00	50	3270S-9X-2.30	■	■	■	■	■
2.40	4.80	21.60	2.35	6.00	50	3270S-9X-2.40	■	■	■	■	■
2.50	5.00	22.50	2.45	6.00	50	3270S-9X-2.50	■	■	■	■	■
3.00	6.00	27.00	2.95	6.00	50	3270S-9X-3.00	■	■	■	■	■

Micro-fraises de précision

Mikropräzisionsfräser

Precision micro end mills

3279T-3X

new

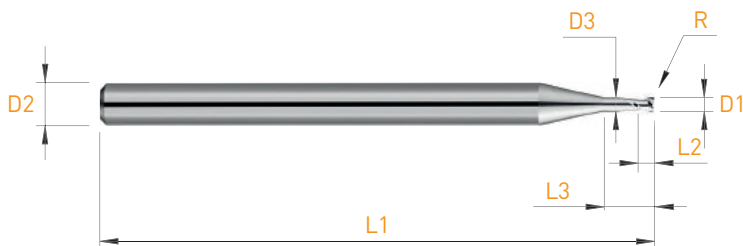

D1 +0.005 / -0.010	R +/- 0.02	L2	L3	D3	D2 h4 Ø3.0 h5 Ø6.0	L1	Art. N°	Z	TiAlN	STF	TiCN	DLC
0.30	0.05	0.60	0.90	0.27	3.00	39	3279T-3X-0.30	■	■	■	■	■
0.40	0.05	0.80	1.20	0.37	3.00	39	3279T-3X-0.40	■	■	■	■	■
0.50	0.05	1.00	1.50	0.45	3.00	39	3279T-3X-0.50	■	■	■	■	■
0.60	0.05	1.20	1.80	0.55	3.00	39	3279T-3X-0.60	■	■	■	■	■
0.70	0.05	1.40	2.10	0.65	3.00	39	3279T-3X-0.70	■	■	■	■	■
0.80	0.05	1.60	2.40	0.75	3.00	39	3279T-3X-0.80	■	■	■	■	■
0.90	0.05	1.80	2.70	0.85	3.00	39	3279T-3X-0.90	■	■	■	■	■
1.00	0.10	2.00	3.00	0.95	3.00	39	3279T-3X-1.00	■	■	■	■	■
1.10	0.10	2.20	3.30	1.05	3.00	39	3279T-3X-1.10	■	■	■	■	■
1.20	0.10	2.40	3.60	1.15	3.00	39	3279T-3X-1.20	■	■	■	■	■
1.30	0.10	2.60	3.90	1.25	3.00	39	3279T-3X-1.30	■	■	■	■	■
1.40	0.10	2.80	4.20	1.35	3.00	39	3279T-3X-1.40	■	■	■	■	■
1.50	0.20	3.00	4.50	1.45	3.00	39	3279T-3X-1.50	■	■	■	■	■
1.60	0.20	3.20	4.80	1.55	3.00	39	3279T-3X-1.60	■	■	■	■	■
1.70	0.20	3.40	5.10	1.65	3.00	39	3279T-3X-1.70	■	■	■	■	■
1.80	0.20	3.60	5.40	1.75	3.00	39	3279T-3X-1.80	■	■	■	■	■
1.90	0.20	3.80	5.70	1.85	3.00	39	3279T-3X-1.90	■	■	■	■	■
2.00	0.20	4.00	6.00	1.95	6.00	50	3279T-3X-2.00	■	■	■	■	■
2.10	0.20	4.20	6.30	2.05	6.00	50	3279T-3X-2.10	■	■	■	■	■
2.20	0.20	4.40	6.60	2.15	6.00	50	3279T-3X-2.20	■	■	■	■	■
2.30	0.20	4.60	6.90	2.25	6.00	50	3279T-3X-2.30	■	■	■	■	■
2.40	0.20	4.80	7.20	2.35	6.00	50	3279T-3X-2.40	■	■	■	■	■
2.50	0.20	5.00	7.50	2.45	6.00	50	3279T-3X-2.50	■	■	■	■	■
3.00	0.20	6.00	9.00	2.95	6.00	50	3279T-3X-3.00	■	■	■	■	■

**new**

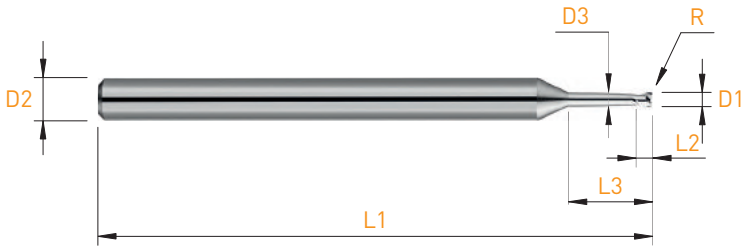

D1 +0.005 / -0.010	R +/- 0.02	L2	L3	D3	D2 h4 Ø3.0 h5 Ø6.0	L1	Art. N°	Z	TiAlN	STF	TiCN	DLC
0.30	0.05	0.60	1.80	0.27	3.00	39	3279T-6X-0.30	■	■	■	■	■
0.40	0.05	0.80	2.40	0.37	3.00	39	3279T-6X-0.40	■	■	■	■	■
0.50	0.05	1.00	3.00	0.45	3.00	39	3279T-6X-0.50	■	■	■	■	■
0.60	0.05	1.20	3.60	0.55	3.00	39	3279T-6X-0.60	■	■	■	■	■
0.70	0.05	1.40	4.20	0.65	3.00	39	3279T-6X-0.70	■	■	■	■	■
0.80	0.05	1.60	4.80	0.75	3.00	39	3279T-6X-0.80	■	■	■	■	■
0.90	0.05	1.80	5.40	0.85	3.00	39	3279T-6X-0.90	■	■	■	■	■
1.00	0.10	2.00	6.00	0.95	3.00	39	3279T-6X-1.00	■	■	■	■	■
1.10	0.10	2.20	6.60	1.05	3.00	39	3279T-6X-1.10	■	■	■	■	■
1.20	0.10	2.40	7.20	1.15	3.00	39	3279T-6X-1.20	■	■	■	■	■
1.30	0.10	2.60	7.80	1.25	3.00	39	3279T-6X-1.30	■	■	■	■	■
1.40	0.10	2.80	8.40	1.35	3.00	39	3279T-6X-1.40	■	■	■	■	■
1.50	0.20	3.00	9.00	1.45	3.00	39	3279T-6X-1.50	■	■	■	■	■
1.60	0.20	3.20	9.60	1.55	3.00	39	3279T-6X-1.60	■	■	■	■	■
1.70	0.20	3.40	10.20	1.65	3.00	39	3279T-6X-1.70	■	■	■	■	■
1.80	0.20	3.60	10.80	1.75	3.00	39	3279T-6X-1.80	■	■	■	■	■
1.90	0.20	3.80	11.40	1.85	3.00	39	3279T-6X-1.90	■	■	■	■	■
2.00	0.20	4.00	12.00	1.95	6.00	50	3279T-6X-2.00	■	■	■	■	■
2.10	0.20	4.20	12.60	2.05	6.00	50	3279T-6X-2.10	■	■	■	■	■
2.20	0.20	4.40	13.20	2.15	6.00	50	3279T-6X-2.20	■	■	■	■	■
2.30	0.20	4.60	13.80	2.25	6.00	50	3279T-6X-2.30	■	■	■	■	■
2.40	0.20	4.80	14.40	2.35	6.00	50	3279T-6X-2.40	■	■	■	■	■
2.50	0.20	5.00	15.00	2.45	6.00	50	3279T-6X-2.50	■	■	■	■	■
3.00	0.20	6.00	18.00	2.95	6.00	50	3279T-6X-3.00	■	■	■	■	■

Micro-fraises de précision

Mikropräzisionsfräser

Precision micro end mills

3279T-9X

new

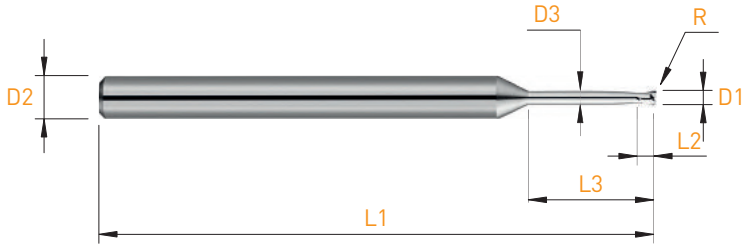

D1 +0.005 / -0.010	R +/- 0.02	L2	L3	D3	D2 h4 Ø3.0 h5 Ø6.0	L1	Art. N°	Z	TiAlN	STF	TiCN	DLC
0.40	0.05	0.80	3.60	0.37	3.00	39	3279T-9X-0.40	■	■	■	■	■
0.50	0.05	1.00	4.50	0.45	3.00	39	3279T-9X-0.50	■	■	■	■	■
0.60	0.05	1.20	5.40	0.55	3.00	39	3279T-9X-0.60	■	■	■	■	■
0.70	0.05	1.40	6.30	0.65	3.00	39	3279T-9X-0.70	■	■	■	■	■
0.80	0.05	1.60	7.20	0.75	3.00	39	3279T-9X-0.80	■	■	■	■	■
0.90	0.05	1.80	8.10	0.85	3.00	39	3279T-9X-0.90	■	■	■	■	■
1.00	0.10	2.00	9.00	0.95	3.00	39	3279T-9X-1.00	■	■	■	■	■
1.10	0.10	2.20	9.90	1.05	3.00	39	3279T-9X-1.10	■	■	■	■	■
1.20	0.10	2.40	10.80	1.15	3.00	39	3279T-9X-1.20	■	■	■	■	■
1.30	0.10	2.60	11.70	1.25	3.00	39	3279T-9X-1.30	■	■	■	■	■
1.40	0.10	2.80	12.60	1.35	3.00	39	3279T-9X-1.40	■	■	■	■	■
1.50	0.20	3.00	13.50	1.45	3.00	39	3279T-9X-1.50	■	■	■	■	■
1.60	0.20	3.20	14.40	1.55	3.00	39	3279T-9X-1.60	■	■	■	■	■
1.70	0.20	3.40	15.30	1.65	3.00	39	3279T-9X-1.70	■	■	■	■	■
1.80	0.20	3.60	16.20	1.75	3.00	39	3279T-9X-1.80	■	■	■	■	■
1.90	0.20	3.80	17.10	1.85	3.00	39	3279T-9X-1.90	■	■	■	■	■
2.00	0.20	4.00	18.00	1.95	6.00	50	3279T-9X-2.00	■	■	■	■	■
2.10	0.20	4.20	18.90	2.05	6.00	50	3279T-9X-2.10	■	■	■	■	■
2.20	0.20	4.40	19.80	2.15	6.00	50	3279T-9X-2.20	■	■	■	■	■
2.30	0.20	4.60	20.70	2.25	6.00	50	3279T-9X-2.30	■	■	■	■	■
2.40	0.20	4.80	21.60	2.35	6.00	50	3279T-9X-2.40	■	■	■	■	■
2.50	0.20	5.00	22.50	2.45	6.00	50	3279T-9X-2.50	■	■	■	■	■
3.00	0.20	6.00	27.00	2.95	6.00	50	3279T-9X-3.00	■	■	■	■	■

# MICRO-LINE

Micro-fraises de précision

Mikropräzisionsfräser

Precision micro end mills

## 3371-1.3

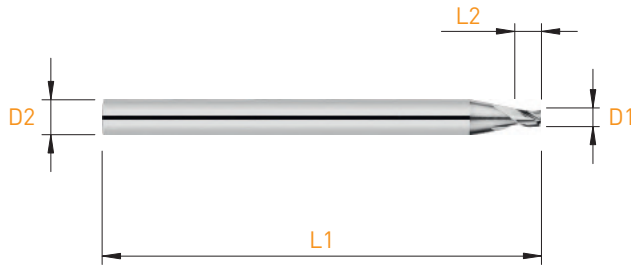

D1 +0.005 / -0.010	L2	D2 h4	L1	Art. N°	Z	TiAlN	STF	TiCN	DLC
0.30	0.40	3.00	39	3371-1.3-0.30	■	■	■	■	■
0.35	0.50	3.00	39	3371-1.3-0.35	■	■	■	■	■
0.40	0.50	3.00	39	3371-1.3-0.40	■	■	■	■	■
0.45	0.60	3.00	39	3371-1.3-0.45	■	■	■	■	■
0.50	0.70	3.00	39	3371-1.3-0.50	■	■	■	■	■
0.60	0.80	3.00	39	3371-1.3-0.60	■	■	■	■	■
0.70	0.90	3.00	39	3371-1.3-0.70	■	■	■	■	■
0.80	1.00	3.00	39	3371-1.3-0.80	■	■	■	■	■
0.90	1.30	3.00	39	3371-1.3-0.90	■	■	■	■	■
1.00	1.30	3.00	39	3371-1.3-1.00	■	■	■	■	■
1.10	1.50	3.00	39	3371-1.3-1.10	■	■	■	■	■
1.20	1.60	3.00	39	3371-1.3-1.20	■	■	■	■	■
1.30	1.80	3.00	39	3371-1.3-1.30	■	■	■	■	■
1.40	1.80	3.00	39	3371-1.3-1.40	■	■	■	■	■
1.50	2.00	3.00	39	3371-1.3-1.50	■	■	■	■	■
1.55	2.00	3.00	39	3371-1.3-1.55	■	■	■	■	■
1.60	2.00	3.00	39	3371-1.3-1.60	■	■	■	■	■
1.65	2.00	3.00	39	3371-1.3-1.65	■	■	■	■	■
1.70	2.00	3.00	39	3371-1.3-1.70	■	■	■	■	■
1.80	2.40	3.00	39	3371-1.3-1.80	■	■	■	■	■
1.90	2.40	3.00	39	3371-1.3-1.90	■	■	■	■	■
2.00	2.60	3.00	39	3371-1.3-2.00	■	■	■	■	■
2.05	2.70	3.00	39	3371-1.3-2.05	■	■	■	■	■
2.20	3.00	3.00	39	3371-1.3-2.20	■	■	■	■	■
2.50	3.30	3.00	39	3371-1.3-2.50	■	■	■	■	■
2.80	3.50	3.00	39	3371-1.3-2.80	■	■	■	■	■
2.90	3.50	3.00	39	3371-1.3-2.90	■	■	■	■	■



Micro-fraises de précision

Mikropräzisionsfräser

Precision micro end mills

3371-2

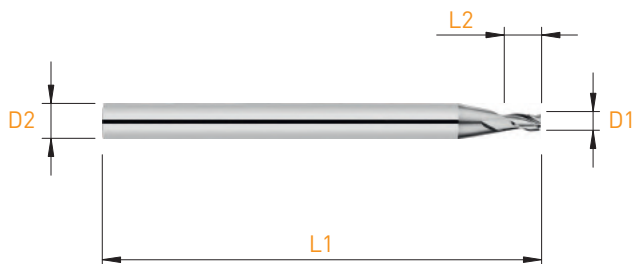

D1 +0.005 / -0.010	L2	D2 h4	L1	Art. N°	Z	TiAlN	STF	TiCN	DLC
0.30	0.60	3.00	39	3371-2-0.30	■	■	■	■	■
0.35	0.70	3.00	39	3371-2-0.35	■	■	■	■	■
0.40	0.80	3.00	39	3371-2-0.40	■	■	■	■	■
0.45	0.90	3.00	39	3371-2-0.45	■	■	■	■	■
0.50	1.00	3.00	39	3371-2-0.50	■	■	■	■	■
0.60	1.20	3.00	39	3371-2-0.60	■	■	■	■	■
0.70	1.40	3.00	39	3371-2-0.70	■	■	■	■	■
0.75	1.50	3.00	39	3371-2-0.75	■	■	■	■	■
0.80	1.60	3.00	39	3371-2-0.80	■	■	■	■	■
0.90	1.80	3.00	39	3371-2-0.90	■	■	■	■	■
0.95	1.90	3.00	39	3371-2-0.95	■	■	■	■	■
1.00	2.00	3.00	39	3371-2-1.00	■	■	■	■	■
1.10	2.20	3.00	39	3371-2-1.10	■	■	■	■	■
1.20	2.40	3.00	39	3371-2-1.20	■	■	■	■	■
1.30	2.60	3.00	39	3371-2-1.30	■	■	■	■	■
1.40	2.80	3.00	39	3371-2-1.40	■	■	■	■	■
1.50	3.00	3.00	39	3371-2-1.50	■	■	■	■	■
1.60	3.20	3.00	39	3371-2-1.60	■	■	■	■	■
1.70	3.40	3.00	39	3371-2-1.70	■	■	■	■	■
1.80	3.60	3.00	39	3371-2-1.80	■	■	■	■	■
1.90	3.80	3.00	39	3371-2-1.90	■	■	■	■	■
2.00	4.00	3.00	39	3371-2-2.00	■	■	■	■	■
2.10	4.20	3.00	39	3371-2-2.10	■	■	■	■	■
2.20	4.40	3.00	39	3371-2-2.20	■	■	■	■	■
2.30	4.60	3.00	39	3371-2-2.30	■	■	■	■	■
2.40	4.80	3.00	39	3371-2-2.40	■	■	■	■	■
2.50	5.00	3.00	39	3371-2-2.50	■	■	■	■	■
2.60	5.20	3.00	39	3371-2-2.60	■	■	■	■	■
2.70	5.40	3.00	39	3371-2-2.70	■	■	■	■	■
2.80	5.60	3.00	39	3371-2-2.80	■	■	■	■	■
2.90	5.80	3.00	39	3371-2-2.90	■	■	■	■	■

# MICRO-LINE

Micro-fraises de précision

Mikropräzisionsfräser

Precision micro end mills

## 3371-3

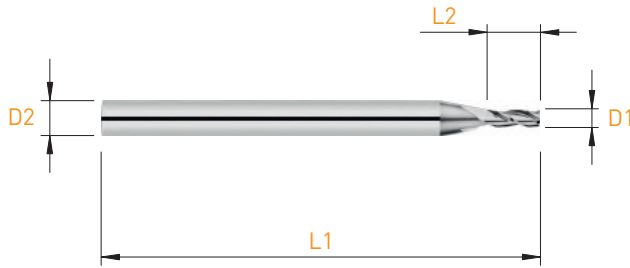

D1 +0.005 / -0.010	L2	D2 h4	L1	Art. N°	N	TiAIN	STF	TiCN	DLC
0.30	0.90	3.00	39	3371-3-0.30	■	■	■	■	■
0.40	1.20	3.00	39	3371-3-0.40	■	■	■	■	■
0.45	1.40	3.00	39	3371-3-0.45	■	■	■	■	■
0.50	1.50	3.00	39	3371-3-0.50	■	■	■	■	■
0.55	1.80	3.00	39	3371-3-0.55	■	■	■	■	■
0.60	2.00	3.00	39	3371-3-0.60	■	■	■	■	■
0.65	2.00	3.00	39	3371-3-0.65	■	■	■	■	■
0.70	2.00	3.00	39	3371-3-0.70	■	■	■	■	■
0.75	2.00	3.00	39	3371-3-0.75	■	■	■	■	■
0.80	2.50	3.00	39	3371-3-0.80	■	■	■	■	■
0.85	2.50	3.00	39	3371-3-0.85	■	■	■	■	■
0.90	2.50	3.00	39	3371-3-0.90	■	■	■	■	■
0.95	2.90	3.00	39	3371-3-0.95	■	■	■	■	■
1.00	3.00	3.00	39	3371-3-1.00	■	■	■	■	■
1.05	3.20	3.00	39	3371-3-1.05	■	■	■	■	■
1.10	3.30	3.00	39	3371-3-1.10	■	■	■	■	■
1.15	3.50	3.00	39	3371-3-1.15	■	■	■	■	■
1.20	4.00	3.00	39	3371-3-1.20	■	■	■	■	■
1.25	4.00	3.00	39	3371-3-1.25	■	■	■	■	■
1.30	4.00	3.00	39	3371-3-1.30	■	■	■	■	■
1.35	4.00	3.00	39	3371-3-1.35	■	■	■	■	■
1.40	4.00	3.00	39	3371-3-1.40	■	■	■	■	■
1.45	4.50	3.00	39	3371-3-1.45	■	■	■	■	■
1.50	4.50	3.00	39	3371-3-1.50	■	■	■	■	■
1.60	4.50	3.00	39	3371-3-1.60	■	■	■	■	■
1.65	5.00	3.00	39	3371-3-1.65	■	■	■	■	■
1.70	5.00	3.00	39	3371-3-1.70	■	■	■	■	■
1.80	6.00	3.00	39	3371-3-1.80	■	■	■	■	■
1.85	6.00	3.00	39	3371-3-1.85	■	■	■	■	■
1.90	6.00	3.00	39	3371-3-1.90	■	■	■	■	■
1.95	6.00	3.00	39	3371-3-1.95	■	■	■	■	■

D1 +0.005 / -0.010	L2	D2 h4	L1	Art. N°	N	TiAIN	STF	TiCN	DLC
2.00	6.00	3.00	39	3371-3-2.00	■	■	■	■	■
2.10	6.00	3.00	39	3371-3-2.10	■	■	■	■	■
2.20	6.50	3.00	39	3371-3-2.20	■	■	■	■	■
2.30	7.00	3.00	39	3371-3-2.30	■	■	■	■	■
2.40	7.00	3.00	39	3371-3-2.40	■	■	■	■	■
2.50	7.50	3.00	39	3371-3-2.50	■	■	■	■	■
2.60	7.50	3.00	39	3371-3-2.60	■	■	■	■	■
2.70	8.00	3.00	39	3371-3-2.70	■	■	■	■	■
2.80	8.00	3.00	39	3371-3-2.80	■	■	■	■	■
2.90	8.50	3.00	39	3371-3-2.90	■	■	■	■	■

Micro-fraises de précision

Mikropräzisionsfräser

Precision micro end mills

3371-4

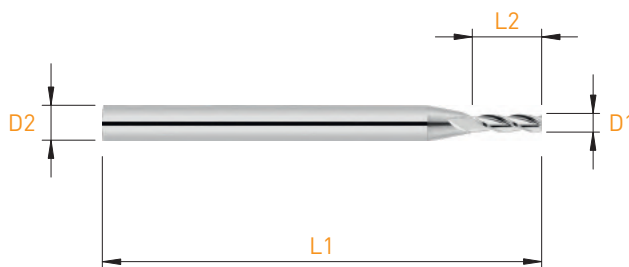

D1 +0.005 / -0.010	L2	D2 h4	L1	Art. N°	Z	TiAIN	STF	TiCN	DLC
0.30	1.20	3.00	39	3371-4-0.30	■	■	■	■	■
0.40	1.60	3.00	39	3371-4-0.40	■	■	■	■	■
0.50	2.00	3.00	39	3371-4-0.50	■	■	■	■	■
0.60	2.40	3.00	39	3371-4-0.60	■	■	■	■	■
0.70	2.80	3.00	39	3371-4-0.70	■	■	■	■	■
0.80	3.20	3.00	39	3371-4-0.80	■	■	■	■	■
0.90	3.60	3.00	39	3371-4-0.90	■	■	■	■	■
1.00	4.00	3.00	39	3371-4-1.00	■	■	■	■	■
1.10	4.40	3.00	39	3371-4-1.10	■	■	■	■	■
1.20	4.80	3.00	39	3371-4-1.20	■	■	■	■	■
1.30	5.20	3.00	39	3371-4-1.30	■	■	■	■	■
1.40	5.60	3.00	39	3371-4-1.40	■	■	■	■	■
1.50	6.00	3.00	39	3371-4-1.50	■	■	■	■	■
1.60	6.40	3.00	39	3371-4-1.60	■	■	■	■	■
1.70	6.80	3.00	39	3371-4-1.70	■	■	■	■	■
1.80	7.20	3.00	39	3371-4-1.80	■	■	■	■	■
1.90	7.60	3.00	39	3371-4-1.90	■	■	■	■	■
2.00	8.00	3.00	39	3371-4-2.00	■	■	■	■	■
2.10	8.40	3.00	39	3371-4-2.10	■	■	■	■	■
2.20	8.80	3.00	39	3371-4-2.20	■	■	■	■	■
2.30	9.20	3.00	39	3371-4-2.30	■	■	■	■	■
2.40	9.60	3.00	39	3371-4-2.40	■	■	■	■	■
2.50	10.00	3.00	39	3371-4-2.50	■	■	■	■	■
2.60	10.40	3.00	39	3371-4-2.60	■	■	■	■	■
2.70	10.80	3.00	39	3371-4-2.70	■	■	■	■	■
2.80	11.20	3.00	39	3371-4-2.80	■	■	■	■	■
2.90	11.60	3.00	39	3371-4-2.90	■	■	■	■	■

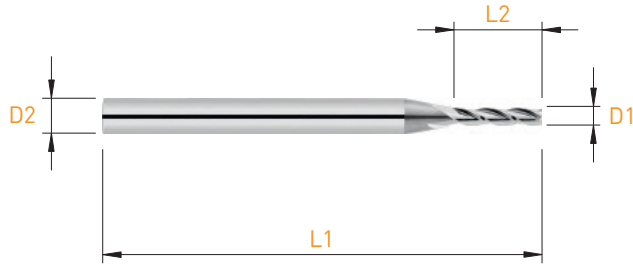

D1 +0.005 / -0.010	L2	D2 h4	L1	Art. N°	N	TiAlN	STF	TiCN	DLC
0.50	2.50	3.00	39	3371-5-0.50	■	■	■	■	■
0.60	3.00	3.00	39	3371-5-0.60	■	■	■	■	■
0.70	3.50	3.00	39	3371-5-0.70	■	■	■	■	■
0.80	4.00	3.00	39	3371-5-0.80	■	■	■	■	■
0.90	4.50	3.00	39	3371-5-0.90	■	■	■	■	■
1.00	5.00	3.00	39	3371-5-1.00	■	■	■	■	■
1.10	5.50	3.00	39	3371-5-1.10	■	■	■	■	■
1.20	6.00	3.00	39	3371-5-1.20	■	■	■	■	■
1.50	7.50	3.00	39	3371-5-1.50	■	■	■	■	■
2.00	10.00	3.00	39	3371-5-2.00	■	■	■	■	■
2.50	12.50	3.00	39	3371-5-2.50	■	■	■	■	■

Micro-fraises de précision

Mikropräzisionsfräser

Precision micro end mills

3371-8

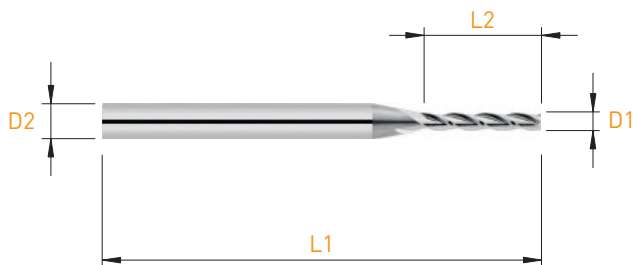

D1 +0.005 / -0.010	L2	D2 h4 Ø3.0 h5 Ø4.0	L1	Art. N°	Z	TiAIN	STF	TiCN	DLC
0.50	4.00	3.00	39	3371-8-0.50	■	■	■	■	■
0.60	5.00	3.00	39	3371-8-0.60	■	■	■	■	■
0.70	5.60	3.00	39	3371-8-0.70	■	■	■	■	■
0.80	6.00	3.00	39	3371-8-0.80	■	■	■	■	■
0.90	7.20	3.00	39	3371-8-0.90	■	■	■	■	■
1.00	8.00	3.00	39	3371-8-1.00	■	■	■	■	■
1.20	9.00	3.00	39	3371-8-1.20	■	■	■	■	■
1.30	11.00	3.00	39	3371-8-1.30	■	■	■	■	■
1.50	12.00	4.00	50	3371-8-1.50	■	■	■	■	■
2.00	16.00	4.00	50	3371-8-2.00	■	■	■	■	■
2.50	20.00	4.00	50	3371-8-2.50	■	■	■	■	■

# MICRO-LINE

Micro-fraises de précision

Mikropräzisionsfräser

Precision micro end mills

## 3375-2.5

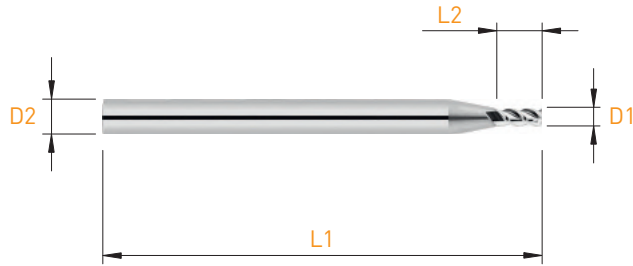

D1 +0.005 / -0.010	L2	D2 h4	L1	Art. N°	Z	TiAlN	STF	TiCN	DLC
0.30	0.80	3.00	39	3375-2.5-0.30	■	■	■	■	■
0.40	1.00	3.00	39	3375-2.5-0.40	■	■	■	■	■
0.50	1.30	3.00	39	3375-2.5-0.50	■	■	■	■	■
0.60	1.50	3.00	39	3375-2.5-0.60	■	■	■	■	■
0.70	1.70	3.00	39	3375-2.5-0.70	■	■	■	■	■
0.80	2.00	3.00	39	3375-2.5-0.80	■	■	■	■	■
0.90	2.30	3.00	39	3375-2.5-0.90	■	■	■	■	■
1.00	2.50	3.00	39	3375-2.5-1.00	■	■	■	■	■
1.10	2.80	3.00	39	3375-2.5-1.10	■	■	■	■	■
1.20	3.00	3.00	39	3375-2.5-1.20	■	■	■	■	■
1.30	3.30	3.00	39	3375-2.5-1.30	■	■	■	■	■
1.40	3.50	3.00	39	3375-2.5-1.40	■	■	■	■	■
1.50	3.80	3.00	39	3375-2.5-1.50	■	■	■	■	■
1.60	4.00	3.00	39	3375-2.5-1.60	■	■	■	■	■
1.70	4.30	3.00	39	3375-2.5-1.70	■	■	■	■	■
1.80	4.50	3.00	39	3375-2.5-1.80	■	■	■	■	■
1.90	4.80	3.00	39	3375-2.5-1.90	■	■	■	■	■
2.00	5.00	3.00	39	3375-2.5-2.00	■	■	■	■	■
2.10	5.30	3.00	39	3375-2.5-2.10	■	■	■	■	■
2.20	5.50	3.00	39	3375-2.5-2.20	■	■	■	■	■
2.30	5.80	3.00	39	3375-2.5-2.30	■	■	■	■	■
2.40	6.00	3.00	39	3375-2.5-2.40	■	■	■	■	■
2.50	6.30	3.00	39	3375-2.5-2.50	■	■	■	■	■
2.60	6.50	3.00	39	3375-2.5-2.60	■	■	■	■	■
2.70	6.80	3.00	39	3375-2.5-2.70	■	■	■	■	■
2.80	7.00	3.00	39	3375-2.5-2.80	■	■	■	■	■
2.90	7.30	3.00	39	3375-2.5-2.90	■	■	■	■	■

Micro-fraises de précision

Mikropräzisionsfräser

Precision micro end mills

DHD3371-1.5

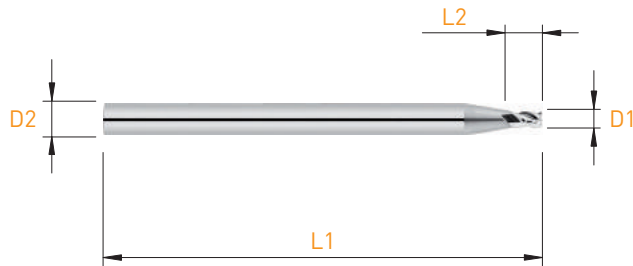

DHD Denture à pas irrégulier, angle d'hélice différent pour chaque dent  
 Ungleiche Teilung, unterschiedlicher Dratlwinkel  
 Uneven tooth pitch, different helix angle per tooth

D1 +0.005 / -0.010	L2	D2 h4	L1	Art. N°	Z	TiAlN	STF	TiCN	DLC
0.30	0.45	3.00	39	DHD3371-1.5-0.30	■	■	■	■	■
0.40	0.60	3.00	39	DHD3371-1.5-0.40	■	■	■	■	■
0.50	0.75	3.00	39	DHD3371-1.5-0.50	■	■	■	■	■
0.60	0.90	3.00	39	DHD3371-1.5-0.60	■	■	■	■	■
0.70	1.05	3.00	39	DHD3371-1.5-0.70	■	■	■	■	■
0.80	1.20	3.00	39	DHD3371-1.5-0.80	■	■	■	■	■
0.90	1.35	3.00	39	DHD3371-1.5-0.90	■	■	■	■	■
1.00	1.50	3.00	39	DHD3371-1.5-1.00	■	■	■	■	■
1.10	1.65	3.00	39	DHD3371-1.5-1.10	■	■	■	■	■
1.20	1.80	3.00	39	DHD3371-1.5-1.20	■	■	■	■	■
1.30	1.95	3.00	39	DHD3371-1.5-1.30	■	■	■	■	■
1.40	2.10	3.00	39	DHD3371-1.5-1.40	■	■	■	■	■
1.50	2.25	3.00	39	DHD3371-1.5-1.50	■	■	■	■	■
1.60	2.40	3.00	39	DHD3371-1.5-1.60	■	■	■	■	■
1.70	2.55	3.00	39	DHD3371-1.5-1.70	■	■	■	■	■
1.80	2.70	3.00	39	DHD3371-1.5-1.80	■	■	■	■	■
1.90	2.85	3.00	39	DHD3371-1.5-1.90	■	■	■	■	■
2.00	3.00	3.00	39	DHD3371-1.5-2.00	■	■	■	■	■
2.50	3.75	3.00	39	DHD3371-1.5-2.50	■	■	■	■	■

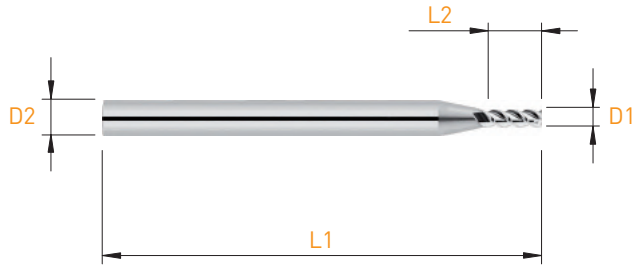

**DHD** Denture à pas irrégulier, angle d'hélice différent pour chaque dent  
 Ungleiche Teilung, unterschiedlicher Drallwinkel  
 Uneven tooth pitch, different helix angle per tooth

D1 +0.005 / -0.010	L2	D2 h4	L1	Art. N°	Z	TiAlN	STF	TiCN	DLC
0.30	0.90	3.00	39	DHD3371-3-0.30	■	■	■	■	■
0.40	1.20	3.00	39	DHD3371-3-0.40	■	■	■	■	■
0.50	1.50	3.00	39	DHD3371-3-0.50	■	■	■	■	■
0.60	1.80	3.00	39	DHD3371-3-0.60	■	■	■	■	■
0.70	2.10	3.00	39	DHD3371-3-0.70	■	■	■	■	■
0.80	2.40	3.00	39	DHD3371-3-0.80	■	■	■	■	■
0.90	2.70	3.00	39	DHD3371-3-0.90	■	■	■	■	■
1.00	3.00	3.00	39	DHD3371-3-1.00	■	■	■	■	■
1.10	3.30	3.00	39	DHD3371-3-1.10	■	■	■	■	■
1.20	3.60	3.00	39	DHD3371-3-1.20	■	■	■	■	■
1.30	3.90	3.00	39	DHD3371-3-1.30	■	■	■	■	■
1.40	4.20	3.00	39	DHD3371-3-1.40	■	■	■	■	■
1.50	4.50	3.00	39	DHD3371-3-1.50	■	■	■	■	■
1.60	4.80	3.00	39	DHD3371-3-1.60	■	■	■	■	■
1.70	5.10	3.00	39	DHD3371-3-1.70	■	■	■	■	■
1.80	5.40	3.00	39	DHD3371-3-1.80	■	■	■	■	■
1.90	5.70	3.00	39	DHD3371-3-1.90	■	■	■	■	■
2.00	6.00	3.00	39	DHD3371-3-2.00	■	■	■	■	■
2.50	7.50	3.00	39	DHD3371-3-2.50	■	■	■	■	■



Micro-fraises de précision

Mikropräzisionsfräser

Precision micro end mills

3370S-3X

new

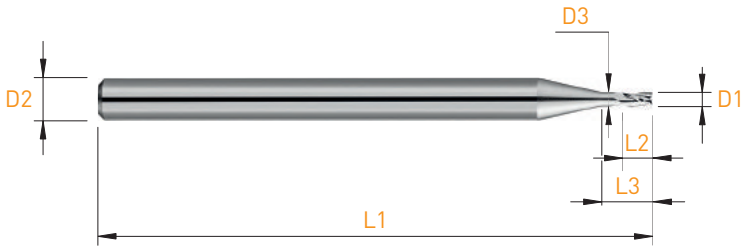

MD VHM HM  $\lambda 30^\circ$  Sharp Corner  L3 3xD1 Z=3 

D1 +0.005 / -0.010	L2	L3	D3	D2 h4 Ø3.0 h5 Ø6.0	L1	Art. N°	Z	TiAIN	STF	TiCN	DLC
0.30	0.60	0.90	0.27	3.00	39	3370S-3X-0.30	■	■	■	■	■
0.40	0.80	1.20	0.37	3.00	39	3370S-3X-0.40	■	■	■	■	■
0.50	1.00	1.50	0.45	3.00	39	3370S-3X-0.50	■	■	■	■	■
0.60	1.20	1.80	0.55	3.00	39	3370S-3X-0.60	■	■	■	■	■
0.70	1.40	2.10	0.65	3.00	39	3370S-3X-0.70	■	■	■	■	■
0.80	1.60	2.40	0.75	3.00	39	3370S-3X-0.80	■	■	■	■	■
0.90	1.80	2.70	0.85	3.00	39	3370S-3X-0.90	■	■	■	■	■
1.00	2.00	3.00	0.95	3.00	39	3370S-3X-1.00	■	■	■	■	■
1.10	2.20	3.30	1.05	3.00	39	3370S-3X-1.10	■	■	■	■	■
1.20	2.40	3.60	1.15	3.00	39	3370S-3X-1.20	■	■	■	■	■
1.30	2.60	3.90	1.25	3.00	39	3370S-3X-1.30	■	■	■	■	■
1.40	2.80	4.20	1.35	3.00	39	3370S-3X-1.40	■	■	■	■	■
1.50	3.00	4.50	1.45	3.00	39	3370S-3X-1.50	■	■	■	■	■
1.60	3.20	4.80	1.55	3.00	39	3370S-3X-1.60	■	■	■	■	■
1.70	3.40	5.10	1.65	3.00	39	3370S-3X-1.70	■	■	■	■	■
1.80	3.60	5.40	1.75	3.00	39	3370S-3X-1.80	■	■	■	■	■
1.90	3.80	5.70	1.85	3.00	39	3370S-3X-1.90	■	■	■	■	■
2.00	4.00	6.00	1.95	6.00	50	3370S-3X-2.00	■	■	■	■	■
2.10	4.20	6.30	2.05	6.00	50	3370S-3X-2.10	■	■	■	■	■
2.20	4.40	6.60	2.15	6.00	50	3370S-3X-2.20	■	■	■	■	■
2.30	4.60	6.90	2.25	6.00	50	3370S-3X-2.30	■	■	■	■	■
2.40	4.80	7.20	2.35	6.00	50	3370S-3X-2.40	■	■	■	■	■
2.50	5.00	7.50	2.45	6.00	50	3370S-3X-2.50	■	■	■	■	■
3.00	6.00	9.00	2.95	6.00	50	3370S-3X-3.00	■	■	■	■	■

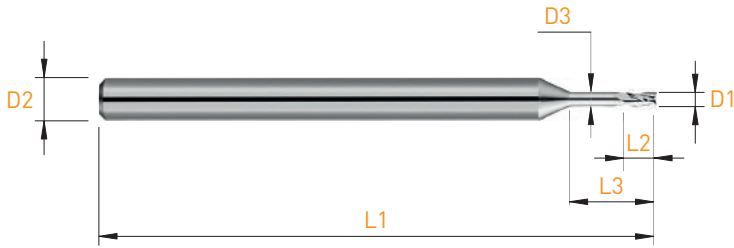

MD VHM HM  $\lambda 30^\circ$  Sharp Corner L3 6xD1 Z=3

D1 +0.005 / -0.010	L2	L3	D3	D2 h4 Ø3.0 h5 Ø6.0	L1	Art. N°	Z	TiAIN	STF	TiCN	DLC
0.30	0.60	1.80	0.27	3.00	39	3370S-6X-0.30	■	■	■	■	■
0.40	0.80	2.40	0.37	3.00	39	3370S-6X-0.40	■	■	■	■	■
0.50	1.00	3.00	0.45	3.00	39	3370S-6X-0.50	■	■	■	■	■
0.60	1.20	3.60	0.55	3.00	39	3370S-6X-0.60	■	■	■	■	■
0.70	1.40	4.20	0.65	3.00	39	3370S-6X-0.70	■	■	■	■	■
0.80	1.60	4.80	0.75	3.00	39	3370S-6X-0.80	■	■	■	■	■
0.90	1.80	5.40	0.85	3.00	39	3370S-6X-0.90	■	■	■	■	■
1.00	2.00	6.00	0.95	3.00	39	3370S-6X-1.00	■	■	■	■	■
1.10	2.20	6.60	1.05	3.00	39	3370S-6X-1.10	■	■	■	■	■
1.20	2.40	7.20	1.15	3.00	39	3370S-6X-1.20	■	■	■	■	■
1.30	2.60	7.80	1.25	3.00	39	3370S-6X-1.30	■	■	■	■	■
1.40	2.80	8.40	1.35	3.00	39	3370S-6X-1.40	■	■	■	■	■
1.50	3.00	9.00	1.45	3.00	39	3370S-6X-1.50	■	■	■	■	■
1.60	3.20	9.60	1.55	3.00	39	3370S-6X-1.60	■	■	■	■	■
1.70	3.40	10.20	1.65	3.00	39	3370S-6X-1.70	■	■	■	■	■
1.80	3.60	10.80	1.75	3.00	39	3370S-6X-1.80	■	■	■	■	■
1.90	3.80	11.40	1.85	3.00	39	3370S-6X-1.90	■	■	■	■	■
2.00	4.00	12.00	1.95	6.00	50	3370S-6X-2.00	■	■	■	■	■
2.10	4.20	12.60	2.05	6.00	50	3370S-6X-2.10	■	■	■	■	■
2.20	4.40	13.20	2.15	6.00	50	3370S-6X-2.20	■	■	■	■	■
2.30	4.60	13.80	2.25	6.00	50	3370S-6X-2.30	■	■	■	■	■
2.40	4.80	14.40	2.35	6.00	50	3370S-6X-2.40	■	■	■	■	■
2.50	5.00	15.00	2.45	6.00	50	3370S-6X-2.50	■	■	■	■	■
3.00	6.00	18.00	2.95	6.00	50	3370S-6X-3.00	■	■	■	■	■

Micro-fraises de précision

Mikropräzisionsfräser

Precision micro end mills

3370S-9X

**new**



MD VHM HM  $\lambda$  30° Sharp Corner  L3 9xD1 Z=3 

D1 +0.005 / -0.010	L2	L3	D3	D2 h4 Ø3.0 h5 Ø6.0	L1	Art. N°	Z	TiAIN	STF	TiCN	DLC
0.40	0.80	3.60	0.37	3.00	39	3370S-9X-0.40	■	■	■	■	■
0.50	1.00	4.50	0.45	3.00	39	3370S-9X-0.50	■	■	■	■	■
0.60	1.20	5.40	0.55	3.00	39	3370S-9X-0.60	■	■	■	■	■
0.70	1.40	6.30	0.65	3.00	39	3370S-9X-0.70	■	■	■	■	■
0.80	1.60	7.20	0.75	3.00	39	3370S-9X-0.80	■	■	■	■	■
0.90	1.80	8.10	0.85	3.00	39	3370S-9X-0.90	■	■	■	■	■
1.00	2.00	9.00	0.95	3.00	39	3370S-9X-1.00	■	■	■	■	■
1.10	2.20	9.90	1.05	3.00	39	3370S-9X-1.10	■	■	■	■	■
1.20	2.40	10.80	1.15	3.00	39	3370S-9X-1.20	■	■	■	■	■
1.30	2.60	11.70	1.25	3.00	39	3370S-9X-1.30	■	■	■	■	■
1.40	2.80	12.60	1.35	3.00	39	3370S-9X-1.40	■	■	■	■	■
1.50	3.00	13.50	1.45	3.00	39	3370S-9X-1.50	■	■	■	■	■
1.60	3.20	14.40	1.55	3.00	39	3370S-9X-1.60	■	■	■	■	■
1.70	3.40	15.30	1.65	3.00	39	3370S-9X-1.70	■	■	■	■	■
1.80	3.60	16.20	1.75	3.00	39	3370S-9X-1.80	■	■	■	■	■
1.90	3.80	17.10	1.85	3.00	39	3370S-9X-1.90	■	■	■	■	■
2.00	4.00	18.00	1.95	6.00	50	3370S-9X-2.00	■	■	■	■	■
2.10	4.20	18.90	2.05	6.00	50	3370S-9X-2.10	■	■	■	■	■
2.20	4.40	19.80	2.15	6.00	50	3370S-9X-2.20	■	■	■	■	■
2.30	4.60	20.70	2.25	6.00	50	3370S-9X-2.30	■	■	■	■	■
2.40	4.80	21.60	2.35	6.00	50	3370S-9X-2.40	■	■	■	■	■
2.50	5.00	22.50	2.45	6.00	50	3370S-9X-2.50	■	■	■	■	■
3.00	6.00	27.00	2.95	6.00	50	3370S-9X-3.00	■	■	■	■	■

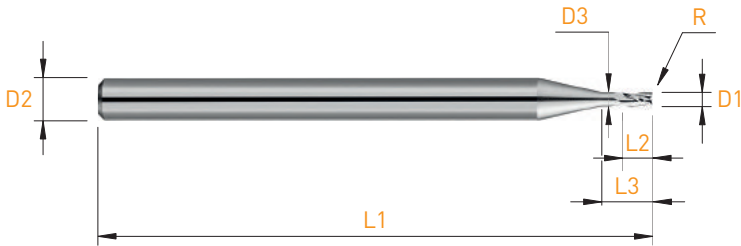

D1 +0.005 / -0.010	R +/- 0.02	L2	L3	D3	D2 h4 Ø3.0 h5 Ø6.0	L1	Art. N°	Z	TiAlN	STF	TiCN	DLC
0.30	0.05	0.60	0.90	0.27	3.00	39	3379T-3X-0.30	■	■	■	■	■
0.40	0.05	0.80	1.20	0.37	3.00	39	3379T-3X-0.40	■	■	■	■	■
0.50	0.05	1.00	1.50	0.45	3.00	39	3379T-3X-0.50	■	■	■	■	■
0.60	0.05	1.20	1.80	0.55	3.00	39	3379T-3X-0.60	■	■	■	■	■
0.70	0.05	1.40	2.10	0.65	3.00	39	3379T-3X-0.70	■	■	■	■	■
0.80	0.05	1.60	2.40	0.75	3.00	39	3379T-3X-0.80	■	■	■	■	■
0.90	0.05	1.80	2.70	0.85	3.00	39	3379T-3X-0.90	■	■	■	■	■
1.00	0.10	2.00	3.00	0.95	3.00	39	3379T-3X-1.00	■	■	■	■	■
1.10	0.10	2.20	3.30	1.05	3.00	39	3379T-3X-1.10	■	■	■	■	■
1.20	0.10	2.40	3.60	1.15	3.00	39	3379T-3X-1.20	■	■	■	■	■
1.30	0.10	2.60	3.90	1.25	3.00	39	3379T-3X-1.30	■	■	■	■	■
1.40	0.10	2.80	4.20	1.35	3.00	39	3379T-3X-1.40	■	■	■	■	■
1.50	0.20	3.00	4.50	1.45	3.00	39	3379T-3X-1.50	■	■	■	■	■
1.60	0.20	3.20	4.80	1.55	3.00	39	3379T-3X-1.60	■	■	■	■	■
1.70	0.20	3.40	5.10	1.65	3.00	39	3379T-3X-1.70	■	■	■	■	■
1.80	0.20	3.60	5.40	1.75	3.00	39	3379T-3X-1.80	■	■	■	■	■
1.90	0.20	3.80	5.70	1.85	3.00	39	3379T-3X-1.90	■	■	■	■	■
2.00	0.20	4.00	6.00	1.95	6.00	50	3379T-3X-2.00	■	■	■	■	■
2.10	0.20	4.20	6.30	2.05	6.00	50	3379T-3X-2.10	■	■	■	■	■
2.20	0.20	4.40	6.60	2.15	6.00	50	3379T-3X-2.20	■	■	■	■	■
2.30	0.20	4.60	6.90	2.25	6.00	50	3379T-3X-2.30	■	■	■	■	■
2.40	0.20	4.80	7.20	2.35	6.00	50	3379T-3X-2.40	■	■	■	■	■
2.50	0.20	5.00	7.50	2.45	6.00	50	3379T-3X-2.50	■	■	■	■	■
3.00	0.20	6.00	9.00	2.95	6.00	50	3379T-3X-3.00	■	■	■	■	■

Micro-fraises de précision

Mikropräzisionsfräser

Precision micro end mills

3379T-6X



D1 +0.005 / -0.010	R +/- 0.02	L2	L3	D3	D2 h4 Ø3.0 h5 Ø6.0	L1	Art. N°	Z	TiAlN	STF	TiCN	DLC
0.30	0.05	0.60	1.80	0.27	3.00	39	3379T-6X-0.30	■	■	■	■	■
0.40	0.05	0.80	2.40	0.37	3.00	39	3379T-6X-0.40	■	■	■	■	■
0.50	0.05	1.00	3.00	0.45	3.00	39	3379T-6X-0.50	■	■	■	■	■
0.60	0.05	1.20	3.60	0.55	3.00	39	3379T-6X-0.60	■	■	■	■	■
0.70	0.05	1.40	4.20	0.65	3.00	39	3379T-6X-0.70	■	■	■	■	■
0.80	0.05	1.60	4.80	0.75	3.00	39	3379T-6X-0.80	■	■	■	■	■
0.90	0.05	1.80	5.40	0.85	3.00	39	3379T-6X-0.90	■	■	■	■	■
1.00	0.10	2.00	6.00	0.95	3.00	39	3379T-6X-1.00	■	■	■	■	■
1.10	0.10	2.20	6.60	1.05	3.00	39	3379T-6X-1.10	■	■	■	■	■
1.20	0.10	2.40	7.20	1.15	3.00	39	3379T-6X-1.20	■	■	■	■	■
1.30	0.10	2.60	7.80	1.25	3.00	39	3379T-6X-1.30	■	■	■	■	■
1.40	0.10	2.80	8.40	1.35	3.00	39	3379T-6X-1.40	■	■	■	■	■
1.50	0.20	3.00	9.00	1.45	3.00	39	3379T-6X-1.50	■	■	■	■	■
1.60	0.20	3.20	9.60	1.55	3.00	39	3379T-6X-1.60	■	■	■	■	■
1.70	0.20	3.40	10.20	1.65	3.00	39	3379T-6X-1.70	■	■	■	■	■
1.80	0.20	3.60	10.80	1.75	3.00	39	3379T-6X-1.80	■	■	■	■	■
1.90	0.20	3.80	11.40	1.85	3.00	39	3379T-6X-1.90	■	■	■	■	■
2.00	0.20	4.00	12.00	1.95	6.00	50	3379T-6X-2.00	■	■	■	■	■
2.10	0.20	4.20	12.60	2.05	6.00	50	3379T-6X-2.10	■	■	■	■	■
2.20	0.20	4.40	13.20	2.15	6.00	50	3379T-6X-2.20	■	■	■	■	■
2.30	0.20	4.60	13.80	2.25	6.00	50	3379T-6X-2.30	■	■	■	■	■
2.40	0.20	4.80	14.40	2.35	6.00	50	3379T-6X-2.40	■	■	■	■	■
2.50	0.20	5.00	15.00	2.45	6.00	50	3379T-6X-2.50	■	■	■	■	■
3.00	0.20	6.00	18.00	2.95	6.00	50	3379T-6X-3.00	■	■	■	■	■

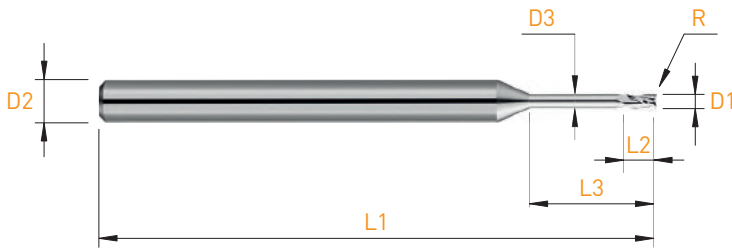

D1 +0.005 / -0.010	R +/- 0.02	L2	L3	D3	D2 h4 Ø3.0 h5 Ø6.0	L1	Art. N°	Z	TiAlN	STF	TiCN	DLC
0.40	0.05	0.80	3.60	0.37	3.00	39	3379T-9X-0.40	■	■	■	■	■
0.50	0.05	1.00	4.50	0.45	3.00	39	3379T-9X-0.50	■	■	■	■	■
0.60	0.05	1.20	5.40	0.55	3.00	39	3379T-9X-0.60	■	■	■	■	■
0.70	0.05	1.40	6.30	0.65	3.00	39	3379T-9X-0.70	■	■	■	■	■
0.80	0.05	1.60	7.20	0.75	3.00	39	3379T-9X-0.80	■	■	■	■	■
0.90	0.05	1.80	8.10	0.85	3.00	39	3379T-9X-0.90	■	■	■	■	■
1.00	0.10	2.00	9.00	0.95	3.00	39	3379T-9X-1.00	■	■	■	■	■
1.10	0.10	2.20	9.90	1.05	3.00	39	3379T-9X-1.10	■	■	■	■	■
1.20	0.10	2.40	10.80	1.15	3.00	39	3379T-9X-1.20	■	■	■	■	■
1.30	0.10	2.60	11.70	1.25	3.00	39	3379T-9X-1.30	■	■	■	■	■
1.40	0.10	2.80	12.60	1.35	3.00	39	3379T-9X-1.40	■	■	■	■	■
1.50	0.20	3.00	13.50	1.45	3.00	39	3379T-9X-1.50	■	■	■	■	■
1.60	0.20	3.20	14.40	1.55	3.00	39	3379T-9X-1.60	■	■	■	■	■
1.70	0.20	3.40	15.30	1.65	3.00	39	3379T-9X-1.70	■	■	■	■	■
1.80	0.20	3.60	16.20	1.75	3.00	39	3379T-9X-1.80	■	■	■	■	■
1.90	0.20	3.80	17.10	1.85	3.00	39	3379T-9X-1.90	■	■	■	■	■
2.00	0.20	4.00	18.00	1.95	6.00	50	3379T-9X-2.00	■	■	■	■	■
2.10	0.20	4.20	18.90	2.05	6.00	50	3379T-9X-2.10	■	■	■	■	■
2.20	0.20	4.40	19.80	2.15	6.00	50	3379T-9X-2.20	■	■	■	■	■
2.30	0.20	4.60	20.70	2.25	6.00	50	3379T-9X-2.30	■	■	■	■	■
2.40	0.20	4.80	21.60	2.35	6.00	50	3379T-9X-2.40	■	■	■	■	■
2.50	0.20	5.00	22.50	2.45	6.00	50	3379T-9X-2.50	■	■	■	■	■
3.00	0.20	6.00	27.00	2.95	6.00	50	3379T-9X-3.00	■	■	■	■	■

Micro-fraises de précision

Mikropräzisionsfräser

Precision micro end mills

3471-1.5

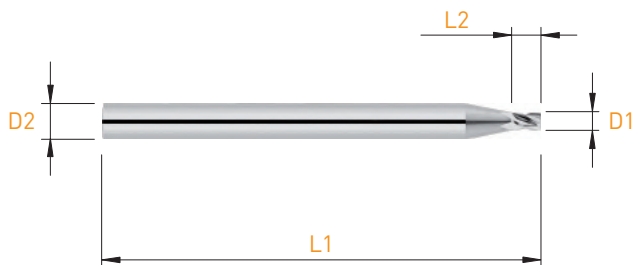

D1 +0.005 / -0.010	L2	D2 h4	L1	Art. N°	N	TiAlN	STF	TiCN	DLC
0.30	0.45	3.00	39	3471-1.5-0.30	■	■	■	■	■
0.40	0.60	3.00	39	3471-1.5-0.40	■	■	■	■	■
0.50	0.75	3.00	39	3471-1.5-0.50	■	■	■	■	■
0.60	0.90	3.00	39	3471-1.5-0.60	■	■	■	■	■
0.70	1.05	3.00	39	3471-1.5-0.70	■	■	■	■	■
0.80	1.20	3.00	39	3471-1.5-0.80	■	■	■	■	■
0.90	1.35	3.00	39	3471-1.5-0.90	■	■	■	■	■
1.00	1.50	3.00	39	3471-1.5-1.00	■	■	■	■	■
1.10	1.65	3.00	39	3471-1.5-1.10	■	■	■	■	■
1.20	1.80	3.00	39	3471-1.5-1.20	■	■	■	■	■
1.30	1.95	3.00	39	3471-1.5-1.30	■	■	■	■	■
1.40	2.10	3.00	39	3471-1.5-1.40	■	■	■	■	■
1.50	2.25	3.00	39	3471-1.5-1.50	■	■	■	■	■
1.60	2.40	3.00	39	3471-1.5-1.60	■	■	■	■	■
1.70	2.55	3.00	39	3471-1.5-1.70	■	■	■	■	■
1.80	2.70	3.00	39	3471-1.5-1.80	■	■	■	■	■
1.90	2.85	3.00	39	3471-1.5-1.90	■	■	■	■	■
2.00	3.00	3.00	39	3471-1.5-2.00	■	■	■	■	■
2.10	3.15	3.00	39	3471-1.5-2.10	■	■	■	■	■
2.20	3.30	3.00	39	3471-1.5-2.20	■	■	■	■	■
2.30	3.45	3.00	39	3471-1.5-2.30	■	■	■	■	■
2.40	3.60	3.00	39	3471-1.5-2.40	■	■	■	■	■
2.50	3.75	3.00	39	3471-1.5-2.50	■	■	■	■	■
2.60	3.90	3.00	39	3471-1.5-2.60	■	■	■	■	■
2.70	4.05	3.00	39	3471-1.5-2.70	■	■	■	■	■
2.80	4.20	3.00	39	3471-1.5-2.80	■	■	■	■	■
2.90	4.35	3.00	39	3471-1.5-2.90	■	■	■	■	■

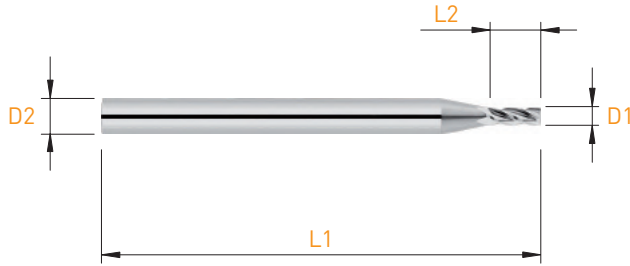

D1 +0.005 / -0.010	L2	D2 h4	L1	Art. N°	N	TiAlN	STF	TiCN	DLC
0.30	0.90	3.00	39	3471-3-0.30	■	■	■	■	■
0.40	1.20	3.00	39	3471-3-0.40	■	■	■	■	■
0.50	1.50	3.00	39	3471-3-0.50	■	■	■	■	■
0.55	1.70	3.00	39	3471-3-0.55	■	■	■	■	■
0.60	1.80	3.00	39	3471-3-0.60	■	■	■	■	■
0.70	2.10	3.00	39	3471-3-0.70	■	■	■	■	■
0.75	2.30	3.00	39	3471-3-0.75	■	■	■	■	■
0.80	2.40	3.00	39	3471-3-0.80	■	■	■	■	■
0.85	2.60	3.00	39	3471-3-0.85	■	■	■	■	■
0.90	2.70	3.00	39	3471-3-0.90	■	■	■	■	■
0.95	2.90	3.00	39	3471-3-0.95	■	■	■	■	■
1.00	3.00	3.00	39	3471-3-1.00	■	■	■	■	■
1.10	3.30	3.00	39	3471-3-1.10	■	■	■	■	■
1.20	3.60	3.00	39	3471-3-1.20	■	■	■	■	■
1.30	3.90	3.00	39	3471-3-1.30	■	■	■	■	■
1.40	4.20	3.00	39	3471-3-1.40	■	■	■	■	■
1.50	4.50	3.00	39	3471-3-1.50	■	■	■	■	■
1.60	4.80	3.00	39	3471-3-1.60	■	■	■	■	■
1.70	5.10	3.00	39	3471-3-1.70	■	■	■	■	■
1.80	5.40	3.00	39	3471-3-1.80	■	■	■	■	■
1.90	5.70	3.00	39	3471-3-1.90	■	■	■	■	■
2.00	6.00	3.00	39	3471-3-2.00	■	■	■	■	■
2.10	6.30	3.00	39	3471-3-2.10	■	■	■	■	■
2.20	6.60	3.00	39	3471-3-2.20	■	■	■	■	■
2.30	6.90	3.00	39	3471-3-2.30	■	■	■	■	■
2.40	7.20	3.00	39	3471-3-2.40	■	■	■	■	■
2.50	7.50	3.00	39	3471-3-2.50	■	■	■	■	■
2.60	7.80	3.00	39	3471-3-2.60	■	■	■	■	■
2.70	8.10	3.00	39	3471-3-2.70	■	■	■	■	■
2.80	8.40	3.00	39	3471-3-2.80	■	■	■	■	■
2.90	8.70	3.00	39	3471-3-2.90	■	■	■	■	■



Micro-fraises de précision

Mikropräzisionsfräser

Precision micro end mills

DHP3471-3

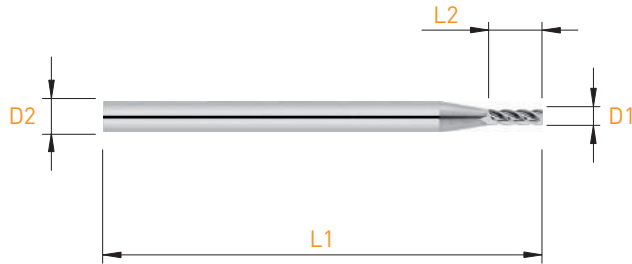

DHP Denture à pas irrégulier, angle d'hélice progressive  
 Ungleiche Teilung, progressive Drallwinkel  
 Uneven tooth pitch, progressive helix angle

D1 +0.005 / -0.010	L2	D2 h4	L1	Art. N°	N	TiAlN	STF	TiCN	DLC
0.50	1.50	3.00	39	DHP3471-3-0.50	■	■	■	■	■
0.60	1.80	3.00	39	DHP3471-3-0.60	■	■	■	■	■
0.70	2.10	3.00	39	DHP3471-3-0.70	■	■	■	■	■
0.80	2.40	3.00	39	DHP3471-3-0.80	■	■	■	■	■
0.90	2.70	3.00	39	DHP3471-3-0.90	■	■	■	■	■
1.00	3.00	3.00	39	DHP3471-3-1.00	■	■	■	■	■
1.10	3.30	3.00	39	DHP3471-3-1.10	■	■	■	■	■
1.20	3.60	3.00	39	DHP3471-3-1.20	■	■	■	■	■
1.30	3.90	3.00	39	DHP3471-3-1.30	■	■	■	■	■
1.40	4.20	3.00	39	DHP3471-3-1.40	■	■	■	■	■
1.50	4.50	3.00	39	DHP3471-3-1.50	■	■	■	■	■
1.60	4.80	3.00	39	DHP3471-3-1.60	■	■	■	■	■
1.70	5.10	3.00	39	DHP3471-3-1.70	■	■	■	■	■
1.80	5.40	3.00	39	DHP3471-3-1.80	■	■	■	■	■
1.90	5.70	3.00	39	DHP3471-3-1.90	■	■	■	■	■
2.00	6.00	3.00	39	DHP3471-3-2.00	■	■	■	■	■
2.50	7.50	3.00	39	DHP3471-3-2.50	■	■	■	■	■

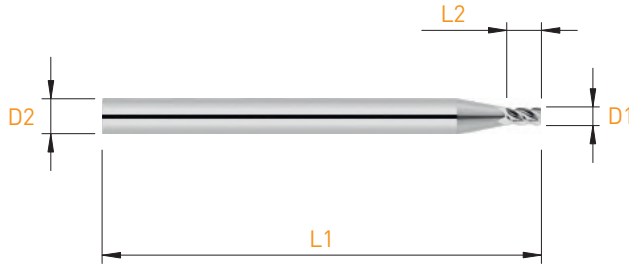

D1 +0.005 / -0.010	L2	D2 h4	L1	Art. N°	Z	TiAIN	STF	TiCN	DLC
0.30	0.60	3.00	39	3472-2-0.30	■	■	■	■	■
0.40	0.80	3.00	39	3472-2-0.40	■	■	■	■	■
0.50	1.00	3.00	39	3472-2-0.50	■	■	■	■	■
0.60	1.20	3.00	39	3472-2-0.60	■	■	■	■	■
0.70	1.40	3.00	39	3472-2-0.70	■	■	■	■	■
0.80	1.60	3.00	39	3472-2-0.80	■	■	■	■	■
0.90	1.80	3.00	39	3472-2-0.90	■	■	■	■	■
1.00	2.00	3.00	39	3472-2-1.00	■	■	■	■	■
1.10	2.20	3.00	39	3472-2-1.10	■	■	■	■	■
1.20	2.40	3.00	39	3472-2-1.20	■	■	■	■	■
1.30	2.60	3.00	39	3472-2-1.30	■	■	■	■	■
1.40	2.80	3.00	39	3472-2-1.40	■	■	■	■	■
1.50	3.00	3.00	39	3472-2-1.50	■	■	■	■	■
1.60	3.20	3.00	39	3472-2-1.60	■	■	■	■	■
1.70	3.40	3.00	39	3472-2-1.70	■	■	■	■	■
1.80	3.60	3.00	39	3472-2-1.80	■	■	■	■	■
1.90	3.80	3.00	39	3472-2-1.90	■	■	■	■	■
2.00	4.00	3.00	39	3472-2-2.00	■	■	■	■	■
2.10	4.20	3.00	39	3472-2-2.10	■	■	■	■	■
2.20	4.40	3.00	39	3472-2-2.20	■	■	■	■	■
2.30	4.60	3.00	39	3472-2-2.30	■	■	■	■	■
2.40	4.80	3.00	39	3472-2-2.40	■	■	■	■	■
2.50	5.00	3.00	39	3472-2-2.50	■	■	■	■	■
2.60	5.20	3.00	39	3472-2-2.60	■	■	■	■	■
2.70	5.40	3.00	39	3472-2-2.70	■	■	■	■	■
2.80	5.60	3.00	39	3472-2-2.80	■	■	■	■	■
2.90	5.80	3.00	39	3472-2-2.90	■	■	■	■	■

Micro-fraises de précision

Mikropräzisionsfräser

Precision micro end mills

3472-4

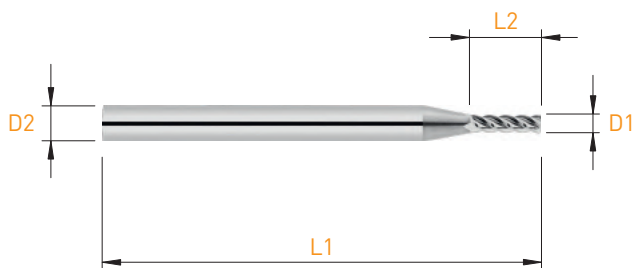

D1 +0.005 / -0.010	L2	D2 h4	L1	Art. N°	Z	TiAlN	STF	TiCN	DLC
0.40	1.60	3.00	39	3472-4-0.40	■	■	■	■	■
0.50	2.00	3.00	39	3472-4-0.50	■	■	■	■	■
0.60	2.40	3.00	39	3472-4-0.60	■	■	■	■	■
0.70	2.80	3.00	39	3472-4-0.70	■	■	■	■	■
0.80	3.20	3.00	39	3472-4-0.80	■	■	■	■	■
0.90	3.60	3.00	39	3472-4-0.90	■	■	■	■	■
1.00	4.00	3.00	39	3472-4-1.00	■	■	■	■	■
1.10	4.40	3.00	39	3472-4-1.10	■	■	■	■	■
1.20	4.80	3.00	39	3472-4-1.20	■	■	■	■	■
1.30	5.20	3.00	39	3472-4-1.30	■	■	■	■	■
1.40	5.60	3.00	39	3472-4-1.40	■	■	■	■	■
1.50	6.00	3.00	39	3472-4-1.50	■	■	■	■	■
1.60	6.40	3.00	39	3472-4-1.60	■	■	■	■	■
1.70	6.80	3.00	39	3472-4-1.70	■	■	■	■	■
1.80	7.20	3.00	39	3472-4-1.80	■	■	■	■	■
1.90	7.60	3.00	39	3472-4-1.90	■	■	■	■	■
2.00	8.00	3.00	39	3472-4-2.00	■	■	■	■	■
2.10	8.40	3.00	39	3472-4-2.10	■	■	■	■	■
2.20	8.80	3.00	39	3472-4-2.20	■	■	■	■	■
2.30	9.20	3.00	39	3472-4-2.30	■	■	■	■	■
2.40	9.60	3.00	39	3472-4-2.40	■	■	■	■	■
2.50	10.00	3.00	39	3472-4-2.50	■	■	■	■	■
2.60	10.40	3.00	39	3472-4-2.60	■	■	■	■	■
2.70	10.80	3.00	39	3472-4-2.70	■	■	■	■	■
2.80	11.20	3.00	39	3472-4-2.80	■	■	■	■	■
2.90	11.60	3.00	39	3472-4-2.90	■	■	■	■	■

# MICRO-LINE

Micro-fraises de précision

Mikropräzisionsfräser

Precision micro end mills

3278-0.75

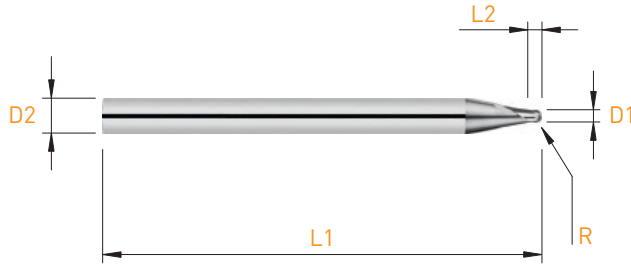

D1 +0.005 / -0.010	R	L2	D2 h4	L1	Art. N°	Z	TiAIN	STF	TiCN	DLC
0.20	0.10	0.15	3.00	39	3278-0.75-0.20	■				
0.30	0.15	0.20	3.00	39	3278-0.75-0.30	■	■	■	■	■
0.40	0.20	0.30	3.00	39	3278-0.75-0.40	■	■	■	■	■
0.50	0.25	0.35	3.00	39	3278-0.75-0.50	■	■	■	■	■
0.60	0.30	0.45	3.00	39	3278-0.75-0.60	■	■	■	■	■
0.70	0.35	0.55	3.00	39	3278-0.75-0.70	■	■	■	■	■
0.80	0.40	0.60	3.00	39	3278-0.75-0.80	■	■	■	■	■
0.90	0.45	0.70	3.00	39	3278-0.75-0.90	■	■	■	■	■
1.00	0.50	0.75	3.00	39	3278-0.75-1.00	■	■	■	■	■
1.50	0.75	1.15	3.00	39	3278-0.75-1.50	■	■	■	■	■
2.00	1.00	1.50	3.00	39	3278-0.75-2.00	■	■	■	■	■
2.50	1.25	1.90	3.00	39	3278-0.75-2.50	■	■	■	■	■

Micro-fraises de précision

Mikropräzisionsfräser

Precision micro end mills

3278-1

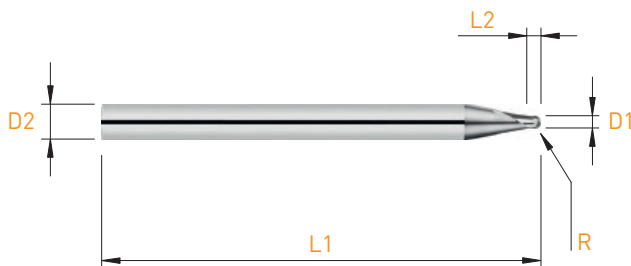

D1 +0.005 / -0.010	R	L2	D2 h4	L1	Art. N°	Z	TiAlN	STF	TiCN	DLC
0.20	0.10	0.20	3.00	39	3278-1-0.20	■				
0.30	0.15	0.30	3.00	39	3278-1-0.30	■	■	■	■	■
0.40	0.20	0.40	3.00	39	3278-1-0.40	■	■	■	■	■
0.50	0.25	0.50	3.00	39	3278-1-0.50	■	■	■	■	■
0.60	0.30	0.60	3.00	39	3278-1-0.60	■	■	■	■	■
0.70	0.35	0.70	3.00	39	3278-1-0.70	■	■	■	■	■
0.80	0.40	0.80	3.00	39	3278-1-0.80	■	■	■	■	■
0.90	0.45	0.90	3.00	39	3278-1-0.90	■	■	■	■	■
1.00	0.50	1.00	3.00	39	3278-1-1.00	■	■	■	■	■
1.10	0.55	1.10	3.00	39	3278-1-1.10	■	■	■	■	■
1.20	0.60	1.20	3.00	39	3278-1-1.20	■	■	■	■	■
1.30	0.35	1.30	3.00	39	3278-1-1.30	■	■	■	■	■
1.40	0.70	1.40	3.00	39	3278-1-1.40	■	■	■	■	■
1.50	0.75	1.50	3.00	39	3278-1-1.50	■	■	■	■	■
1.60	0.80	1.60	3.00	39	3278-1-1.60	■	■	■	■	■
1.70	0.85	1.70	3.00	39	3278-1-1.70	■	■	■	■	■
1.80	0.90	1.80	3.00	39	3278-1-1.80	■	■	■	■	■
1.90	0.95	1.90	3.00	39	3278-1-1.90	■	■	■	■	■
2.00	1.00	2.00	3.00	39	3278-1-2.00	■	■	■	■	■
2.10	1.05	2.10	3.00	39	3278-1-2.10	■	■	■	■	■
2.20	1.10	2.20	3.00	39	3278-1-2.20	■	■	■	■	■
2.30	1.15	2.30	3.00	39	3278-1-2.30	■	■	■	■	■
2.40	1.20	2.40	3.00	39	3278-1-2.40	■	■	■	■	■
2.50	1.25	2.50	3.00	39	3278-1-2.50	■	■	■	■	■
2.60	1.30	2.60	3.00	39	3278-1-2.60	■	■	■	■	■
2.70	1.35	2.70	3.00	39	3278-1-2.70	■	■	■	■	■
2.80	1.40	2.80	3.00	39	3278-1-2.80	■	■	■	■	■
2.90	1.45	2.90	3.00	39	3278-1-2.90	■	■	■	■	■

# MICRO-LINE

Micro-fraises de précision

Mikropräzisionsfräser

Precision micro end mills

## 3278-1.5

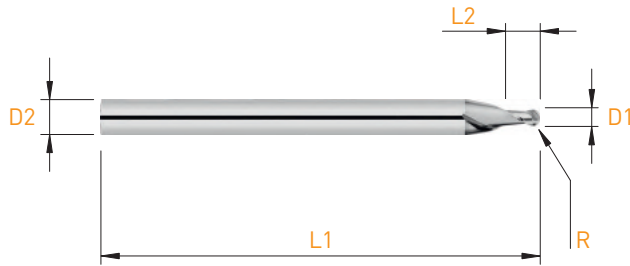

D1 +0.005 / -0.010	R	L2	D2 h4	L1	Art. N°	Z	TiAlN	STF	TiCN	DLC
0.20	0.10	0.30	3.00	39	3278-1.5-0.20	■				
0.25	0.125	0.35	3.00	39	3278-1.5-0.25	■				
0.30	0.15	0.45	3.00	39	3278-1.5-0.30	■	■	■	■	■
0.40	0.20	0.60	3.00	39	3278-1.5-0.40	■	■	■	■	■
0.50	0.25	0.75	3.00	39	3278-1.5-0.50	■	■	■	■	■
0.60	0.30	0.90	3.00	39	3278-1.5-0.60	■	■	■	■	■
0.70	0.35	1.05	3.00	39	3278-1.5-0.70	■	■	■	■	■
0.80	0.40	1.20	3.00	39	3278-1.5-0.80	■	■	■	■	■
0.85	0.40	1.30	3.00	39	3278-1.5-0.85	■	■	■	■	■
0.90	0.45	1.35	3.00	39	3278-1.5-0.90	■	■	■	■	■
1.00	0.50	1.50	3.00	39	3278-1.5-1.00	■	■	■	■	■
1.10	0.55	1.65	3.00	39	3278-1.5-1.10	■	■	■	■	■
1.15	0.55	1.75	3.00	39	3278-1.5-1.15	■	■	■	■	■
1.20	0.60	1.80	3.00	39	3278-1.5-1.20	■	■	■	■	■
1.30	0.65	1.95	3.00	39	3278-1.5-1.30	■	■	■	■	■
1.40	0.70	2.10	3.00	39	3278-1.5-1.40	■	■	■	■	■
1.50	0.75	2.25	3.00	39	3278-1.5-1.50	■	■	■	■	■
1.60	0.80	2.40	3.00	39	3278-1.5-1.60	■	■	■	■	■
1.70	0.85	2.60	3.00	39	3278-1.5-1.70	■	■	■	■	■
1.80	0.90	2.70	3.00	39	3278-1.5-1.80	■	■	■	■	■
1.90	0.95	2.90	3.00	39	3278-1.5-1.90	■	■	■	■	■
2.00	1.00	3.00	3.00	39	3278-1.5-2.00	■	■	■	■	■
2.10	1.05	3.20	3.00	39	3278-1.5-2.10	■	■	■	■	■
2.20	1.10	3.30	3.00	39	3278-1.5-2.20	■	■	■	■	■
2.30	1.15	3.50	3.00	39	3278-1.5-2.30	■	■	■	■	■
2.40	1.20	3.60	3.00	39	3278-1.5-2.40	■	■	■	■	■
2.50	1.25	3.75	3.00	39	3278-1.5-2.50	■	■	■	■	■
2.60	1.30	3.90	3.00	39	3278-1.5-2.60	■	■	■	■	■
2.70	1.35	4.00	3.00	39	3278-1.5-2.70	■	■	■	■	■
2.80	1.40	4.20	3.00	39	3278-1.5-2.80	■	■	■	■	■
2.90	1.45	4.40	3.00	39	3278-1.5-2.90	■	■	■	■	■

Micro-fraises de précision

Mikropräzisionsfräser

Precision micro end mills

3278-3

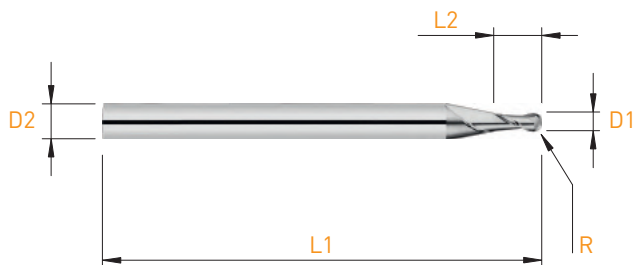

D1 +0.005 / -0.010	R	L2	D2 h4	L1	Art. N°	Z	TiAlN	STF	TiCN	DLC
0.20	0.10	0.60	3.00	39	3278-3-0.20	■				
0.30	0.15	1.00	3.00	39	3278-3-0.30	■	■	■	■	■
0.40	0.20	1.00	3.00	39	3278-3-0.40	■	■	■	■	■
0.50	0.25	1.50	3.00	39	3278-3-0.50	■	■	■	■	■
0.60	0.30	1.50	3.00	39	3278-3-0.60	■	■	■	■	■
0.70	0.35	2.00	3.00	39	3278-3-0.70	■	■	■	■	■
0.80	0.40	2.00	3.00	39	3278-3-0.80	■	■	■	■	■
0.90	0.45	2.50	3.00	39	3278-3-0.90	■	■	■	■	■
1.00	0.50	3.00	3.00	39	3278-3-1.00	■	■	■	■	■
1.20	0.60	4.00	3.00	39	3278-3-1.20	■	■	■	■	■
1.30	0.65	4.00	3.00	39	3278-3-1.30	■	■	■	■	■
1.40	0.70	4.00	3.00	39	3278-3-1.40	■	■	■	■	■
1.50	0.75	4.50	3.00	39	3278-3-1.50	■	■	■	■	■
1.55	0.775	5.00	3.00	39	3278-3-1.55	■	■	■	■	■
1.60	0.80	5.00	3.00	39	3278-3-1.60	■	■	■	■	■
1.80	0.90	5.50	3.00	39	3278-3-1.80	■	■	■	■	■
2.00	1.00	6.00	3.00	39	3278-3-2.00	■	■	■	■	■
2.10	1.05	6.50	3.00	39	3278-3-2.10	■	■	■	■	■
2.20	1.10	7.00	3.00	39	3278-3-2.20	■	■	■	■	■
2.50	1.25	7.50	3.00	39	3278-3-2.50	■	■	■	■	■
2.60	1.30	7.80	3.00	39	3278-3-2.60	■	■	■	■	■
2.70	1.35	8.10	3.00	39	3278-3-2.70	■	■	■	■	■
2.80	1.40	8.40	3.00	39	3278-3-2.80	■	■	■	■	■
2.90	1.45	8.70	3.00	39	3278-3-2.90	■	■	■	■	■

**new**

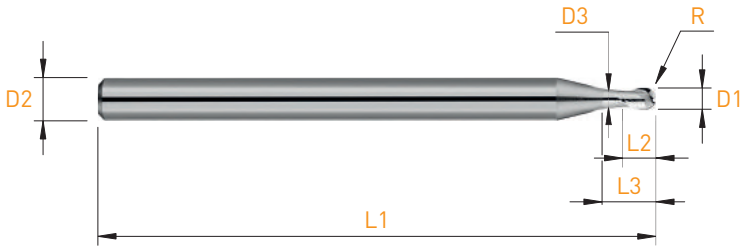

D1 +0.005 / -0.010	R	L2	L3	D3	D2 h4 Ø3.0 h5 Ø6.0	L1	Art. N°	Z	TiAlN	STF	TiCN	DLC
0.20	0.10	0.30	0.60	0.19	3.00	39	3278H-3X-0.20	■				
0.30	0.15	0.45	0.90	0.27	3.00	39	3278H-3X-0.30	■	■	■	■	■
0.40	0.20	0.60	1.20	0.37	3.00	39	3278H-3X-0.40	■	■	■	■	■
0.50	0.25	0.75	1.50	0.45	3.00	39	3278H-3X-0.50	■	■	■	■	■
0.60	0.30	0.90	1.80	0.55	3.00	39	3278H-3X-0.60	■	■	■	■	■
0.70	0.35	1.05	2.10	0.65	3.00	39	3278H-3X-0.70	■	■	■	■	■
0.80	0.40	1.20	2.40	0.75	3.00	39	3278H-3X-0.80	■	■	■	■	■
0.90	0.45	1.35	2.70	0.85	3.00	39	3278H-3X-0.90	■	■	■	■	■
1.00	0.50	1.50	3.00	0.95	3.00	39	3278H-3X-1.00	■	■	■	■	■
1.10	0.55	1.65	3.30	1.05	3.00	39	3278H-3X-1.10	■	■	■	■	■
1.20	0.60	1.80	3.60	1.15	3.00	39	3278H-3X-1.20	■	■	■	■	■
1.30	0.65	1.95	3.90	1.25	3.00	39	3278H-3X-1.30	■	■	■	■	■
1.40	0.70	2.10	4.20	1.35	3.00	39	3278H-3X-1.40	■	■	■	■	■
1.50	0.75	2.25	4.50	1.45	3.00	39	3278H-3X-1.50	■	■	■	■	■
1.60	0.80	2.40	4.80	1.55	3.00	39	3278H-3X-1.60	■	■	■	■	■
1.70	0.85	2.55	5.10	1.65	3.00	39	3278H-3X-1.70	■	■	■	■	■
1.80	0.90	2.70	5.40	1.75	3.00	39	3278H-3X-1.80	■	■	■	■	■
1.90	0.95	2.85	5.70	1.85	3.00	39	3278H-3X-1.90	■	■	■	■	■
2.00	1.00	3.00	6.00	1.95	6.00	50	3278H-3X-2.00	■	■	■	■	■
2.10	1.05	3.15	6.30	2.05	6.00	50	3278H-3X-2.10	■	■	■	■	■
2.20	1.10	3.30	6.60	2.15	6.00	50	3278H-3X-2.20	■	■	■	■	■
2.30	1.15	3.45	6.90	2.25	6.00	50	3278H-3X-2.30	■	■	■	■	■
2.40	1.20	3.60	7.20	2.35	6.00	50	3278H-3X-2.40	■	■	■	■	■
2.50	1.25	3.75	7.50	2.45	6.00	50	3278H-3X-2.50	■	■	■	■	■
3.00	1.50	4.50	9.00	2.95	6.00	50	3278H-3X-3.00	■	■	■	■	■



Micro-fraises de précision

Mikropräzisionsfräser

Precision micro end mills

3278H-6X



D1 +0.005 / -0.010	R	L2	L3	D3	D2 h4 Ø3.0 h5 Ø6.0	L1	Art. N°	Z	TiAlN	STF	TiCN	DLC
0.30	0.15	0.45	1.80	0.27	3.00	39	3278H-6X-0.30	■	■	■	■	■
0.40	0.20	0.60	2.40	0.37	3.00	39	3278H-6X-0.40	■	■	■	■	■
0.50	0.25	0.75	3.00	0.45	3.00	39	3278H-6X-0.50	■	■	■	■	■
0.60	0.30	0.90	3.60	0.55	3.00	39	3278H-6X-0.60	■	■	■	■	■
0.70	0.35	1.05	4.20	0.65	3.00	39	3278H-6X-0.70	■	■	■	■	■
0.80	0.40	1.20	4.80	0.75	3.00	39	3278H-6X-0.80	■	■	■	■	■
0.90	0.45	1.35	5.40	0.85	3.00	39	3278H-6X-0.90	■	■	■	■	■
1.00	0.50	1.50	6.00	0.95	3.00	39	3278H-6X-1.00	■	■	■	■	■
1.10	0.55	1.65	6.60	1.05	3.00	39	3278H-6X-1.10	■	■	■	■	■
1.20	0.60	1.80	7.20	1.15	3.00	39	3278H-6X-1.20	■	■	■	■	■
1.30	0.65	1.95	7.80	1.25	3.00	39	3278H-6X-1.30	■	■	■	■	■
1.40	0.70	2.10	8.40	1.35	3.00	39	3278H-6X-1.40	■	■	■	■	■
1.50	0.75	2.25	9.00	1.45	3.00	39	3278H-6X-1.50	■	■	■	■	■
1.60	0.80	2.40	9.60	1.55	3.00	39	3278H-6X-1.60	■	■	■	■	■
1.70	0.85	2.55	10.20	1.65	3.00	39	3278H-6X-1.70	■	■	■	■	■
1.80	0.90	2.70	10.80	1.75	3.00	39	3278H-6X-1.80	■	■	■	■	■
1.90	0.95	2.85	11.40	1.85	3.00	39	3278H-6X-1.90	■	■	■	■	■
2.00	1.00	3.00	12.00	1.95	6.00	50	3278H-6X-2.00	■	■	■	■	■
2.10	1.05	3.15	12.60	2.05	6.00	50	3278H-6X-2.10	■	■	■	■	■
2.20	1.10	3.30	13.20	2.15	6.00	50	3278H-6X-2.20	■	■	■	■	■
2.30	1.15	3.45	13.80	2.25	6.00	50	3278H-6X-2.30	■	■	■	■	■
2.40	1.20	3.60	14.40	2.35	6.00	50	3278H-6X-2.40	■	■	■	■	■
2.50	1.25	3.75	15.00	2.45	6.00	50	3278H-6X-2.50	■	■	■	■	■
3.00	1.50	4.50	18.00	2.95	6.00	50	3278H-6X-3.00	■	■	■	■	■

# MICRO-LINE

Micro-fraises de précision

Mikropräzisionsfräser

Precision micro end mills

## 3278H-9X

**new**

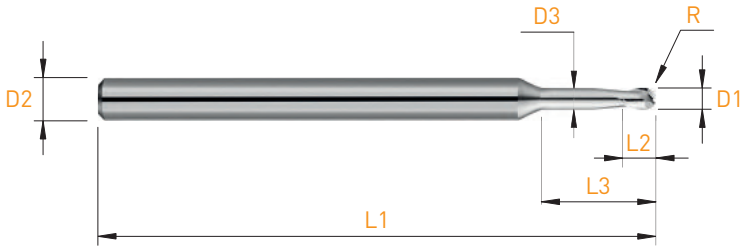

D1 +0.005 / -0.010	R	L2	L3	D3	D2 h4 Ø3.0 h5 Ø6.0	L1	Art. N°	Z	TiAlN	STF	TiCN	DLC
0.40	0.20	0.60	3.60	0.37	3.00	39	3278H-9X-0.40	■	■	■	■	■
0.50	0.25	0.75	4.50	0.45	3.00	39	3278H-9X-0.50	■	■	■	■	■
0.60	0.30	0.90	5.40	0.55	3.00	39	3278H-9X-0.60	■	■	■	■	■
0.70	0.35	1.05	6.30	0.65	3.00	39	3278H-9X-0.70	■	■	■	■	■
0.80	0.40	1.20	7.20	0.75	3.00	39	3278H-9X-0.80	■	■	■	■	■
0.90	0.45	1.35	8.10	0.85	3.00	39	3278H-9X-0.90	■	■	■	■	■
1.00	0.50	1.50	9.00	0.95	3.00	39	3278H-9X-1.00	■	■	■	■	■
1.10	0.55	1.65	9.90	1.05	3.00	39	3278H-9X-1.10	■	■	■	■	■
1.20	0.60	1.80	10.80	1.15	3.00	39	3278H-9X-1.20	■	■	■	■	■
1.30	0.65	1.95	11.70	1.25	3.00	39	3278H-9X-1.30	■	■	■	■	■
1.40	0.70	2.10	12.60	1.35	3.00	39	3278H-9X-1.40	■	■	■	■	■
1.50	0.75	2.25	13.50	1.45	3.00	39	3278H-9X-1.50	■	■	■	■	■
1.60	0.80	2.40	14.40	1.55	3.00	39	3278H-9X-1.60	■	■	■	■	■
1.70	0.85	2.55	15.30	1.65	3.00	39	3278H-9X-1.70	■	■	■	■	■
1.80	0.90	2.70	16.20	1.75	3.00	39	3278H-9X-1.80	■	■	■	■	■
1.90	0.95	2.85	17.10	1.85	3.00	39	3278H-9X-1.90	■	■	■	■	■
2.00	1.00	3.00	18.00	1.95	6.00	50	3278H-9X-2.00	■	■	■	■	■
2.10	1.05	3.15	18.90	2.05	6.00	50	3278H-9X-2.10	■	■	■	■	■
2.20	1.10	3.30	19.80	2.15	6.00	50	3278H-9X-2.20	■	■	■	■	■
2.30	1.15	3.45	20.70	2.25	6.00	50	3278H-9X-2.30	■	■	■	■	■
2.40	1.20	3.60	21.60	2.35	6.00	50	3278H-9X-2.40	■	■	■	■	■
2.50	1.25	3.75	22.50	2.45	6.00	50	3278H-9X-2.50	■	■	■	■	■
3.00	1.50	4.50	27.00	2.95	6.00	50	3278H-9X-3.00	■	■	■	■	■









Fraises en bout





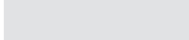

Schaftfräser

End mills

Paramètres de coupe indicatif  
Empfohlene Schnittwerte  
Standard machining data

14.53

	Fraises en bout avec angle vif Schaftfräser mit scharfkantigen Ecken End mills with sharp corners					
	Z	$\lambda$	D1	D2	Type	page
	Z=3	Div.	Ø1.00 - 8.00	Ø3/6/8	E-DHP4300-1.5	14.57
	Z=4	26° / 33°	Ø10.00	Ø10 h6	E-DHP4400-1.5	
	Z=3	Div.	Ø1.00 - 8.00	Ø3/6/8	E-DHP4300-2.5	
	Z=4	26° / 33°	Ø10.00	Ø10h6	E-DHP4400-2.5	
	Z=1	23°	Ø1.00 - 6.00	Ø6h5	3123-2	14.58 <b>new</b>
			Ø1.00 - 6.00	Ø6h5	3123-4	14.59 <b>new</b>
	Z=2	60°	Ø0.50 - 6.00	Ø3/6/8	3260MV	14.60 <b>new</b>
		90°	Ø0.30 - 6.00	Ø3/6/8	3290MV	14.61 <b>new</b>
		120°	Ø0.50 - 6.00	Ø3/6/8	32120MV	14.62 <b>new</b>
	Z=2	30°	Ø1.00 - 6.00	Ø6 h5	3230	14.63
			Ø3.00 - 6.00	Ø6 h5	3230-1.5	14.64 <b>new</b>
			Ø3.00 - 6.00	Ø6 h5	3230-3	14.65 <b>new</b>
			Ø2.00 - 6.00	D1 = D2	3231	14.66
			Ø3.00 - 6.00	Ø6 h5	3239T-2.5X	14.67 <b>new</b>
			Ø3.00 - 6.00	Ø6 h5	3239T-4X	14.68 <b>new</b>
	Z=3	30°	Ø1.00 - 6.00	Ø6 h6	3330-S	14.69
			Ø3.00-12.00	D1 = D2	3330	14.70
			Ø3.00 - 6.00	Ø6 h5	3330-4	14.71 <b>new</b>
			Ø2.00 - 6.00	D1 = D2	3331	14.72
			Ø1.50 - 6.00	Ø6 h5	3336-HA	14.73
			Ø1.50 - 6.00	Ø6 h5	3337-HA	14.73
			Ø2.00 - 6.00	D1 = D2	3341	14.74
			Ø0.50 - 6.00	Ø6 h6	3345-S	14.75 <b>new</b>
	Z=4	30°	Ø3.00 - 6.00	D1 = D2	3430	14.78
			Ø2.00 - 6.00	D1 = D2	3431	14.79
			Ø2.00 - 6.00	D1 = D2	3441	14.80
			Ø0.50 - 6.00	Ø6 h6	3445-S	14.81
			Ø1.00 - 6.00	Ø6 h5	3450	14.82 <b>new</b>
			Ø1.00 - 6.00	Ø6 h5	DHP3436	14.83
	Z=4	30°	Ø3.00 - 6.00	Ø6 h5	3439T-2.5X	14.84 <b>new</b>
			Ø3.00 - 6.00	Ø6 h5	3439T-4X	14.85 <b>new</b>
			Ø1.00 - 6.00	Ø6 h5	3545	14.86 <b>new</b>
			Ø1.00 - 6.00	Ø6 h5	35645	14.87 <b>new</b>
	Z=8	10°	Ø6.00	Ø6 h5	3810	14.88 <b>new</b>

 	Z	$\lambda$	D1	D2	Type	page	
	    	Z=2	30°	Ø2.00 - 6.00	D1 = D2	3238	14.89
Z=3		30°	Ø2.00 - 6.00	D1 = D2	3338	14.90	
Z=3				Ø0.30 - 3.50	Ø6 h5	701S3371-1	
				Ø0.30 - 3.50	Ø6 h5	701S3371-2	14.91
				Ø0.30 - 3.00	Ø6 h5	701S3371-3	
Z=3		30°	Ø8.00-12.00	Ø6h6	3383	14.93	
Z=10		30°	Ø16.3 / 20.30	Ø10h6	3831 / 3833	14.94	
Z=3		0°	Ø0.50 - 3.00	Ø3h4	3611	14.95	<b>new</b>
Z=3		0°	Ø0.50 - 3.00	Ø3h4	3911	14.96	
Z=4		0°	Ø3.00-8.00	Ø3 h4 Ø6 h5 Ø8 h6	3901	14.97	

## Fraises ébauches

## Schrupfräser

## Roughing mills

## Paramètres de coupe indicatifs

## Empfohlene Schnittwerte

## Standard machining data

Matière Werkstoff Material	VC	1.0 - 2.0	2.0 - 4.0	4.0 - 6.0	6.0 - 10.0	Z	TAIN	STF
	(m/min)	fz (mm)	fz (mm)	fz (mm)	fz (mm)			
Acier de décolletage Automatenstahl Free-cutting steel	<b>P</b> 100 - 140	0.010 - 0.015	0.015 - 0.030	0.030 - 0.040	0.040 - 0.060	-	***	***
Acier Stahl Steel < 600 N/mm <sup>2</sup>	<b>P</b> 90 - 140	0.010 - 0.015	0.015 - 0.030	0.030 - 0.040	0.040 - 0.060	-	***	***
Acier Stahl Steel < 800 N/mm <sup>2</sup>	<b>P</b> 90 - 140	0.010 - 0.015	0.015 - 0.030	0.030 - 0.040	0.040 - 0.060	-	***	***
Acier Stahl Steel > 800 N/mm <sup>2</sup>	<b>P</b> 80 - 120	0.010 - 0.015	0.015 - 0.030	0.030 - 0.040	0.040 - 0.060	-	***	***
Acier trempé Gehärteter Stahl -55HRC Hardened steel	<b>H</b> 120 - 170	0.005 - 0.008	0.008 - 0.015	0.015 - 0.020	0.020 - 0.035	-	***	***
Acier trempé Gehärteter Stahl +55HRC Hardened steel	<b>H</b> 110 - 150	0.005 - 0.008	0.008 - 0.015	0.015 - 0.020	0.020 - 0.035	-	***	***
Inox Rostfreistahl Stainless steel	<b>M</b> 50 - 90	0.004 - 0.008	0.008 - 0.012	0.012 - 0.020	0.020 - 0.040	-	***	***
Aluminium	<b>N</b> 250 - 350	0.008 - 0.015	0.015 - 0.030	0.030 - 0.040	0.040 - 0.065	-	***	**
Cuivre, laiton, bronze Kupfer, Messing, Bronze Copper, brass, bronze	<b>N</b> 130 - 240	0.005 - 0.010	0.010 - 0.020	0.020 - 0.030	0.030 - 0.050	-	***	**
Matière synthétique Synthetisches Material Synthetic material	<b>N</b> 150 - 300	0.020 - 0.030	0.030 - 0.050	0.050 - 0.080	0.080 - 0.150	-	***	**
Métaux précieux Edelmetalle Precious metals	<b>N</b> 120 - 150	0.005 - 0.010	0.010 - 0.020	0.020 - 0.030	0.030 - 0.050	-	***	**
Titane Titan Titanium	<b>S</b> 50 - 100	0.010 - 0.015	0.015 - 0.020	0.020 - 0.030	0.030 - 0.050	-	***	***
Alliage de nickel Nickel-Legierung Nickel alloy	<b>S</b> 40 - 60	0.005 - 0.007	0.007-0.012	0.012 - 0.020	0.020 - 0.030	-	***	***
Matière exotique Exotisches material Exotic material	<b>O</b> 15 - 25	0.005 - 0.010	0.010 - 0.020	0.020 - 0.030	0.030 - 0.050	-	***	***

Avec revêtement, augmenter les valeurs de 20-30%

Mit Beschichtung, Daten um 20-30% erhöhen

With coating, increase data by 20-30%

\* Bien / Gut / Good

\*\* Très bien / Sehr Gut / Very good

\*\*\* Excellent / Ausgezeichnet / Excellent

Fraises en bout

Schafffräser

End mills

Paramètres de coupe indicatifs

Empfohlene Schnittwerte

Standard machining data

Matière Werkstoff Material	VC	0.50 - 2.0	2.0 - 4.0	4.0 - 6.0	6.0 - 8.0	8.0 - 12.0	Z	TAIN	STF	DLC
	(m/min)	fz (mm)	fz (mm)	fz (mm)	fz (mm)	fz (mm)				
Acier de décolletage Automatenstahl Free-cutting steel	<b>P</b> 80 - 130	0.004-0.015	0.015 - 0.025	0.025 - 0.035	0.035 - 0.050	0.050 - 0.080	-	***	***	-
Acier Stahl Steel < 600 N/mm <sup>2</sup>	<b>P</b> 70 - 100	0.004-0.015	0.015 - 0.025	0.025 - 0.035	0.035 - 0.050	0.050 - 0.080	-	***	***	-
Acier Stahl Steel < 800 N/mm <sup>2</sup>	<b>P</b> 70 - 100	0.004-0.015	0.015 - 0.025	0.025 - 0.035	0.035 - 0.050	0.050 - 0.080	-	***	***	-
Acier Stahl Steel > 800 N/mm <sup>2</sup>	<b>P</b> 50 - 80	0.004-0.015	0.015 - 0.025	0.025 - 0.035	0.035 - 0.050	0.050 - 0.080	-	***	***	-
Acier trempé Gehärteter Stahl -55HRC Hardened steel	<b>H</b> 60 - 90	0.002 - 0.008	0.008 - 0.015	0.012 - 0.020	0.020 - 0.025	0.025 - 0.030	-	***	***	-
Acier trempé Gehärteter Stahl +55HRC Hardened steel	<b>H</b> 40 - 70	0.002 - 0.008	0.008 - 0.015	0.012 - 0.020	0.020 - 0.025	0.020 - 0.030	-	***	***	-
Inox Rostfreistahl Stainless steel	<b>M</b> 40 - 80	0.003 - 0.008	0.008 - 0.015	0.015 - 0.020	0.020 - 0.030	0.030 - 0.050	-	***	***	-
Aluminium	<b>N</b> 230 - 320	0.003 - 0.010	0.010 - 0.025	0.025 - 0.030	0.030 - 0.050	0.050 - 0.080	**	*	**	***
Cuivre, laiton, bronze Kupfer, Messing, Bronze Copper, brass, bronze	<b>N</b> 100 - 190	0.003 - 0.010	0.010 - 0.020	0.020 - 0.030	0.030 - 0.040	0.040 - 0.070	**	*	**	***
Matière synthétique Synthetisches Material Synthetic material	<b>N</b> 250 - 500	0.005 - 0.030	0.030 - 0.050	0.050 - 0.080	0.080 - 0.100	0.100 - 0.200	***	-	**	***
Métaux précieux Edelmetalle Precious metals	<b>N</b> 90 - 150	0.003 - 0.015	0.015 - 0.025	0.025 - 0.030	0.030 - 0.050	0.050 - 0.080	***	*	**	***
Titane Titan Titanium	<b>S</b> 30 - 70	0.004 - 0.010	0.010 - 0.017	0.017-0.025	0.025 - 0.035	0.035 - 0.050	-	**	***	-
Alliage de nickel Nickel-Legierung Nickel alloy	<b>S</b> 30 - 60	0.003 - 0.008	0.008 - 0.015	0.015 - 0.020	0.020 - 0.025	0.025 - 0.040	-	***	***	-
Matière exotique Exotisches material Exotic material	<b>O</b> 15 - 25	0.002 - 0.008	0.008 - 0.020	0.020 - 0.030	0.030 - 0.040	0.040 - 0.050	-	***	***	**

Avec revêtement, augmenter les valeurs de 20-30%

Mit Beschichtung, Daten um 20-30% erhöhen

With coating, increase data by 20-30%

\* Bien / Gut / Good

\*\* Très bien / Sehr Gut / Very good

\*\*\* Excellent / Ausgezeichnet / Excellent

Outils WM 701S

Werkzeuge WM 701S

Tools WM 701S

Paramètres de coupe indicatifs

Empfohlene Schnittwerte

Standard machining data

Matière Werkstoff Material		VC	Z	TiAlN	STF	DLC
		(m/min)				
Acier de décolletage Automatenstahl Free-cutting steel	P	120 - 180	-	***	***	-
Acier Stahl Steel	< 600 N/mm <sup>2</sup> P	100 - 150	-	***	***	-
Acier Stahl Steel	< 800 N/mm <sup>2</sup> P	100 - 130	-	***	***	-
Acier Stahl Steel	> 800 N/mm <sup>2</sup> P	80 - 100	-	***	***	-
Acier trempé Gehärteter Stahl -55HRC Hardened steel	H	-	-	***	***	-
Acier trempé Gehärteter Stahl +55HRC Hardened steel	H	-	-	***	***	-
Inox Rostfreistahl Stainless steel	M	60 - 90	-	***	***	-
Aluminium	N	250 - 400	**	***	***	***
Cuivre, laiton, bronze Kupfer, Messing, Bronze Copper, brass, bronze	N	150 - 200	***	**	**	***
Matière synthétique Synthetisches Material Synthetic material	N	100 - 150	***	**	**	***
Métaux précieux Edelmetalle Precious metals	N	140 - 200	***	**	**	***
Titane Titan Titanium	S	40 - 70	-	***	***	-
Alliage de nickel Nickel-Legierung Nickel alloy	S	30 - 60	-	***	***	-
Matière exotique Exotisches material Exotic material	O	30 - 60	-	***	***	***

Avec revêtement, augmenter les valeurs de 20-30%

Mit Beschichtung, Daten um 20-30% erhöhen

With coating, increase data by 20-30%

\* Bien / Gut / Good

\*\* Très bien / Sehr Gut / Very good

\*\*\* Excellent / Ausgezeichnet / Excellent

**Fraises à angler**  
**Kegelsenker**  
**Chamfering tools**

**Paramètres de coupe indicatifs**  
**Empfohlene Schnittwerte**  
**Standard machining data**

Matière Werkstoff Material		VC	Z	TAIN	STF
		(m/min)			
Acier de décolletage Automatenstahl Free-cutting steel	P	80 - 130	*	***	***
Acier Stahl Steel	< 600 N/mm <sup>2</sup> P	70 - 100	*	***	***
Acier Stahl Steel	< 800 N/mm <sup>2</sup> P	70 - 100	*	***	***
Acier Stahl Steel	> 800 N/mm <sup>2</sup> P	50 - 80	*	***	***
Acier trempé Gehärteter Stahl Hardened steel	-55HRC H	60 - 90	-	**	***
Acier trempé Gehärteter Stahl Hardened steel	+55HRC H	40 - 70	-	**	***
Inox Rostfreistahl Stainless steel	M	50 - 100	*	***	***
Aluminium	N	200 - 300	***	**	***
Cuivre, laiton, bronze Kupfer, Messing, Bronze Copper, brass, bronze	N	100 - 200	***	**	***
Matière synthétique Synthetisches Material Synthetic material	N	200 - 500	***	**	**
Métaux précieux Edelmetalle Precious metals	N	90 - 140	***	**	***
Titane Titan Titanium	S	30 - 80	-	***	***
Alliage de nickel Nickel-Legierung Nickel alloy	S	30 - 60	-	***	***
Matière exotique Exotisches material Exotic material	O	20 - 30	-	***	***

Avec revêtement, augmenter les valeurs de 20-30%  
 Mit Beschichtung, Daten um 20-30% erhöhen  
 With coating, increase data by 20-30%

\* Bien / Gut / Good  
 \*\* Très bien / Sehr Gut / Very good  
 \*\*\* Excellent / Ausgezeichnet / Excellent



Fraises ébauches

Schrupfräser

Roughing mills

E-DHP3300 / 3400

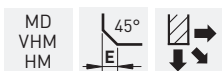
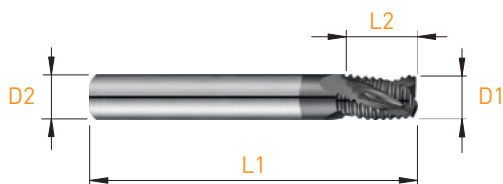

	Z	E	$\lambda$	D1 h10	L2	D2 h6	L1	Art. N°	Z	TiAIN	STF
	3	0.05	26°/30°	1.00	1.50	3.00	39	E-DHP3300-1.5-1.00	■	■	■
	3	0.10	26°/30°	1.50	2.25	3.00	39	E-DHP3300-1.5-1.50	■	■	■
	3	0.20	26°/30°	2.00	3.00	3.00	39	E-DHP3300-1.5-2.00	■	■	■
	3	0.20	26°/33°	2.50	3.75	6.00	50	E-DHP3300-1.5-2.50	■	■	■
	3	0.20	26°/33°	3.00	4.25	6.00	50	E-DHP3300-1.5-3.00	■	■	■
	3	0.30	26°/33°	4.00	6.00	6.00	50	E-DHP3300-1.5-4.00	■	■	■
	3	0.30	26°/33°	5.00	7.50	6.00	50	E-DHP3300-1.5-5.00	■	■	■
	3	0.40	26°/33°	6.00	9.00	6.00	50	E-DHP3300-1.5-6.00	■	■	■
	3	0.50	26°/33°	8.00	12.00	8.00	64	E-DHP3300-1.5-8.00	■	■	■
	4	0.50	26°/33°	10.00	15.00	10.00	73	E-DHP3400-1.5-10.00	■	■	■

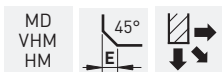
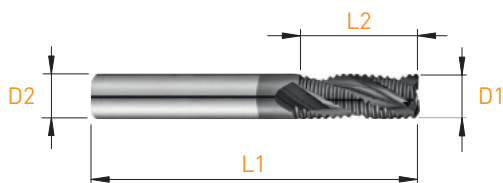

	Z	E	$\lambda$	D1 h10	L2	D2 h6	L1	Art. N°	Z	TiAIN	STF
	3	0.05	26°/30°	1.00	2.50	3.00	39	E-DHP3300-2.5-1.00	■	■	■
	3	0.10	26°/30°	1.50	3.75	3.00	39	E-DHP3300-2.5-1.50	■	■	■
	3	0.20	26°/30°	2.00	5.00	3.00	39	E-DHP3300-2.5-2.00	■	■	■
	3	0.20	26°/33°	2.50	6.25	6.00	58	E-DHP3300-2.5-2.50	■	■	■
	3	0.20	26°/33°	3.00	7.50	6.00	58	E-DHP3300-2.5-3.00	■	■	■
	3	0.30	26°/33°	4.00	10.00	6.00	58	E-DHP3300-2.5-4.00	■	■	■
	3	0.30	26°/33°	5.00	12.50	6.00	58	E-DHP3300-2.5-5.00	■	■	■
	3	0.40	26°/33°	6.00	15.00	6.00	58	E-DHP3300-2.5-6.00	■	■	■
	3	0.50	26°/33°	8.00	20.00	8.00	64	E-DHP3300-2.5-8.00	■	■	■
	4	0.50	26°/33°	10.00	25.00	10.00	73	E-DHP3400-2.5-10.00	■	■	■

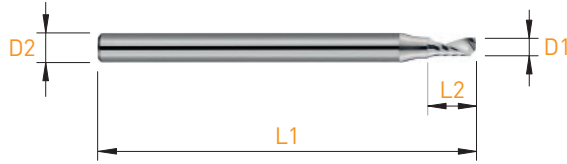

MD VHM HM	$\lambda$ 23°	Sharp Corner		2xD1	Z=1
-----------------	---------------	-----------------	--	------	-----

D1 h10	L2	D2 h5	L1	Art. N°	Z	TiAIN	STF	DLC
1.00	2.00	6.00	50	3123-2-1.0	■	■	■	■
2.00	4.00	6.00	50	3123-2-2.0	■	■	■	■
3.00	6.00	6.00	50	3123-2-3.0	■	■	■	■
4.00	8.00	6.00	50	3123-2-4.0	■	■	■	■
5.00	10.00	6.00	50	3123-2-5.0	■	■	■	■
6.00	12.00	6.00	50	3123-2-6.0	■	■	■	■

Fraises en bout de finition

Schlicht Schafffräser

Finishing end mills

3123-4

new

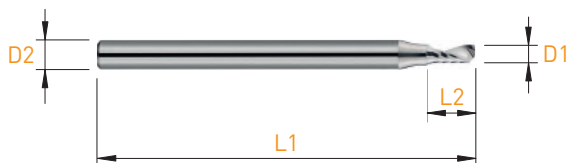

MD VHM HM	$\lambda$ 23°	Sharp Corner		4xD1	Z=1
-----------------	---------------	-----------------	--	------	-----

D1 h10	L2	D2 h5	L1	Art. N°	Z	TiAlN	STF	DLC
1.00	4.00	6.00	50	3123-4-1.0	■	■	■	■
2.00	8.00	6.00	50	3123-4-2.0	■	■	■	■
3.00	12.00	6.00	50	3123-4-3.0	■	■	■	■
4.00	16.00	6.00	50	3123-4-4.0	■	■	■	■
5.00	20.00	6.00	50	3123-4-5.0	■	■	■	■
6.00	24.00	6.00	50	3123-4-6.0	■	■	■	■

**new**

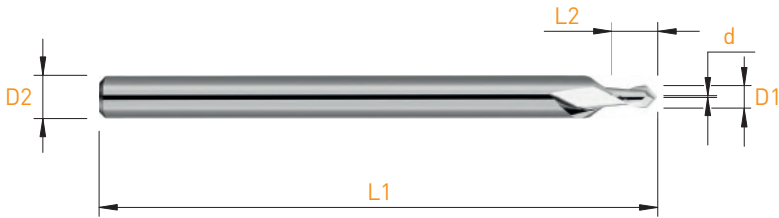

D1 h10	d	L2	D2 Ø3h4 Ø4h5 Ø8h6	L1	Art. N°	Z	TiAlN	STF
0.50	0.05	1.00	3.00	39	3260MV-0.5	■	■	■
1.00	0.10	2.00	3.00	39	3260MV-1.0	■	■	■
1.50	0.15	3.00	3.00	39	3260MV-1.5	■	■	■
2.00	0.20	4.00	3.00	39	3260MV-2.0	■	■	■
2.50	0.25	5.00	3.00	39	3260MV-2.5	■	■	■
3.00	0.30	6.00	6.00	50	3260MV-3.0	■	■	■
4.00	0.40	8.00	6.00	50	3260MV-4.0	■	■	■
6.00	0.60	12.00	8.00	63	3260MV-6.0	■	■	■

Fraises Multi-V

Multi-V Fräser

End mills Multi-V

3290MV

new

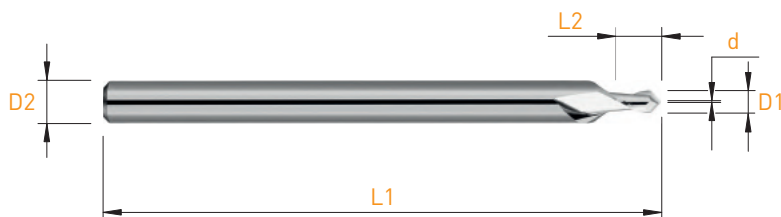

D1 h10	d	L2	D2 Ø3h4 Ø6h5 Ø8h6	L1	Art. N°	Z	TiAlN	STF
0.30	0.03	0.60	3.00	39	3290MV-0.3	■	■	■
0.40	0.04	0.80	3.00	39	3290MV-0.4	■	■	■
0.50	0.05	1.00	3.00	39	3290MV-0.5	■	■	■
0.60	0.06	1.20	3.00	39	3290MV-0.6	■	■	■
0.70	0.07	1.40	3.00	39	3290MV-0.7	■	■	■
0.80	0.08	1.60	3.00	39	3290MV-0.8	■	■	■
0.90	0.09	1.80	3.00	39	3290MV-0.9	■	■	■
1.00	0.10	2.00	3.00	39	3290MV-1.0	■	■	■
1.10	0.11	2.20	3.00	39	3290MV-1.1	■	■	■
1.20	0.12	2.40	3.00	39	3290MV-1.2	■	■	■
1.30	0.13	2.60	3.00	39	3290MV-1.3	■	■	■
1.40	0.14	2.80	3.00	39	3290MV-1.4	■	■	■
1.50	0.15	3.00	3.00	39	3290MV-1.5	■	■	■
1.60	0.16	3.20	3.00	39	3290MV-1.6	■	■	■
1.70	0.17	3.40	3.00	39	3290MV-1.7	■	■	■
1.80	0.18	3.60	3.00	39	3290MV-1.8	■	■	■
1.90	0.19	3.80	3.00	39	3290MV-1.9	■	■	■
2.00	0.20	4.00	3.00	39	3290MV-2.0	■	■	■
2.50	0.25	5.00	3.00	39	3290MV-2.5	■	■	■
3.00	0.30	6.00	6.00	50	3290MV-3.0	■	■	■
4.00	0.40	8.00	6.00	50	3290MV-4.0	■	■	■
6.00	0.60	12.00	8.00	63	3290MV-6.0	■	■	■

**new**



D1 h10	d	L2	D2 Ø3h4 Ø4h5 Ø8h6	L1	Art. N°	Z	TiAlN	STF
0.50	0.05	1.00	3.00	39	32120MV-0.5	■	■	■
1.00	0.10	2.00	3.00	39	32120MV-1.0	■	■	■
1.50	0.15	3.00	3.00	39	32120MV-1.5	■	■	■
2.00	0.20	4.00	3.00	39	32120MV-2.0	■	■	■
2.50	0.25	5.00	3.00	39	32120MV-2.5	■	■	■
3.00	0.30	6.00	6.00	50	32120MV-3.0	■	■	■
4.00	0.40	8.00	6.00	50	32120MV-4.0	■	■	■
6.00	0.60	12.00	8.00	63	32120MV-6.0	■	■	■

Fraises en bout de finition

Schlicht Schafffräser

Finishing end mills

3230

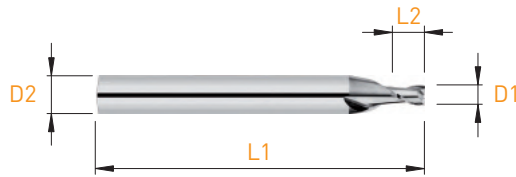

D1 h10	L2	D2 h5	L1	Art. N°	Z	TiAlN	STF
1.00	1.00	6.00	50	3230-1.0	■	■	■
1.50	1.50	6.00	50	3230-1.5	■	■	■
2.00	2.00	6.00	50	3230-2.0	■	■	■
2.50	2.50	6.00	50	3230-2.5	■	■	■
3.00	3.00	6.00	50	3230-3.0	■	■	■
4.00	4.00	6.00	50	3230-4.0	■	■	■
5.00	5.00	6.00	50	3230-5.0	■	■	■
6.00	6.00	6.00	50	3230-6.0	■	■	■

**new**

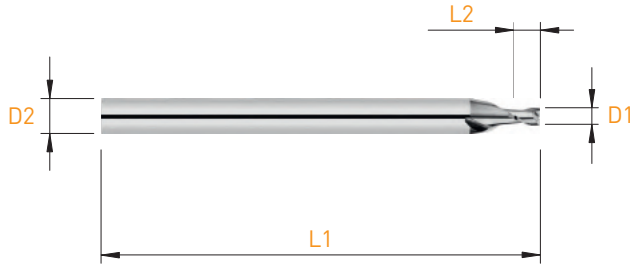

MD VHM HM	$\lambda$ 30°	Sharp Corner		1.5xD1	Z=2	
-----------------	---------------	-----------------	--	--------	-----	--

D1 h10	L2	D2 h5	L1	Art. N°	Z	TIALIN	STF
3.00	4.50	6.00	50	3230-1.5-3.0	■	■	■
3.50	5.00	6.00	50	3230-1.5-3.5	■	■	■
4.00	6.00	6.00	50	3230-1.5-4.0	■	■	■
4.50	7.00	6.00	50	3230-1.5-4.5	■	■	■
5.00	8.00	6.00	50	3230-1.5-5.0	■	■	■
6.00	9.00	6.00	50	3230-1.5-6.0	■	■	■



Fraises en bout de finition

Schlicht Schafffräser

Finishing end mills

3230-3

new

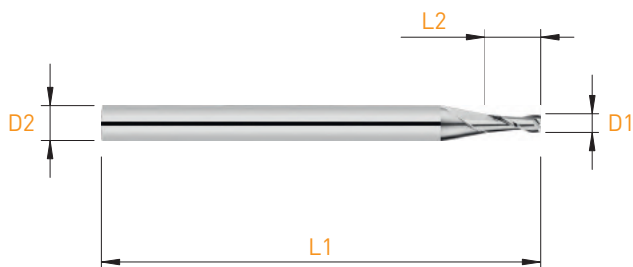

D1 h10	L2	D2 h5	L1	Art. N°	Z	TiAlN	STF
3.00	9.00	6.00	50	3230-3-3.0	■	■	■
3.50	10.00	6.00	50	3230-3-3.5	■	■	■
4.00	12.00	6.00	50	3230-3-4.0	■	■	■
4.50	13.00	6.00	50	3230-3-4.5	■	■	■
5.00	15.00	6.00	50	3230-3-5.0	■	■	■
6.00	18.00	6.00	50	3230-3-6.0	■	■	■

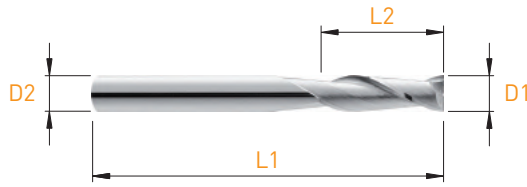

D1 e9	L2	D2 h5	L1	Art. N°	Z	TiAlN	STF
2.00	8.00	2.00	32	3231-2.0	■	■	■
2.50	8.00	2.50	32	3231-2.5	■	■	■
3.00	12.00	3.00	32	3231-3.0	■	■	■
3.50	12.00	3.50	32	3231-3.5	■	■	■
4.00	12.00	4.00	40	3231-4.0	■	■	■
4.50	14.00	4.50	50	3231-4.5	■	■	■
5.00	14.00	5.00	50	3231-5.0	■	■	■
6.00	16.00	6.00	50	3231-6.0	■	■	■

Fraises en bout de finition

Schlicht Schafffräser

Finishing end mills

3239T-2.5X

new

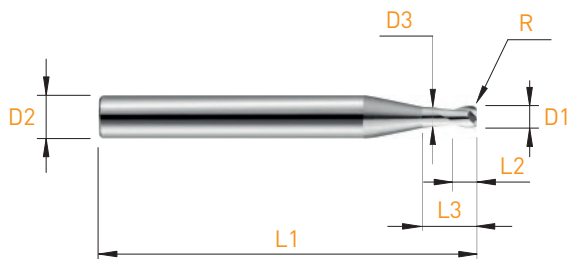

MD VHM HM	$\lambda$ 30°	Radius Corner		L3 2.5xD1	Z=2	
-----------------	---------------	------------------	--	--------------	-----	--

D1 h10	R +/- 0.02	L2	L3	D3	D2 h5	L1	Art. N°	Z	TiAlN	STF
3.00	0.50	3.00	7.50	2.95	6.00	57	3239T-2.5X-3.0	■	■	■
3.50	0.50	3.50	8.75	3.45	6.00	57	3239T-2.5X-3.5	■	■	■
4.00	0.50	4.00	10.00	3.95	6.00	57	3239T-2.5X-4.0	■	■	■
4.50	0.50	4.50	11.25	4.45	6.00	57	3239T-2.5X-4.5	■	■	■
5.00	0.50	5.00	12.50	4.95	6.00	57	3239T-2.5X-5.0	■	■	■
5.50	0.50	5.50	13.75	5.45	6.00	57	3239T-2.5X-5.5	■	■	■
6.00	0.50	6.00	15.00	5.95	6.00	57	3239T-2.5X-6.0	■	■	■

**new**

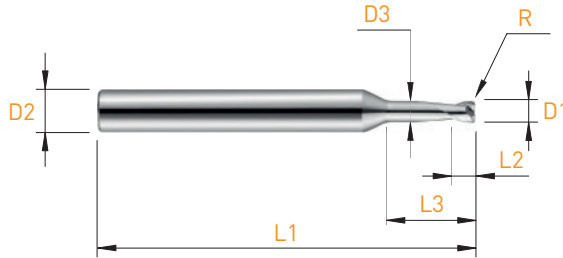

D1 h10	R +/- 0.02	L2	L3	D3	D2 h5	L1	Art. N°	Z	TiAlN	STF
3.00	0.50	3.00	12.00	2.95	6.00	57	3239T-4X-3.0	■	■	■
3.50	0.50	3.50	14.00	3.45	6.00	57	3239T-4X-3.5	■	■	■
4.00	0.50	4.00	16.00	3.95	6.00	57	3239T-4X-4.0	■	■	■
4.50	0.50	4.50	18.00	4.45	6.00	57	3239T-4X-4.5	■	■	■
5.00	0.50	5.00	20.00	4.95	6.00	57	3239T-4X-5.0	■	■	■
5.50	0.50	5.50	22.00	5.45	6.00	57	3239T-4X-5.5	■	■	■
6.00	0.50	6.00	24.00	5.95	6.00	57	3239T-4X-6.0	■	■	■

Fraises en bout de finition

Schlicht Schafffräser

Finishing end mills

3330-S



D1 h10	L2	D2 h6	L1	Art. N°	Z	TiAlN	STF
1.00	3.00	6.00	40	3330-S-1.0	■	■	■
1.50	3.00	6.00	40	3330-S-1.5	■	■	■
2.00	3.00	6.00	40	3330-S-2.0	■	■	■
2.50	3.00	6.00	40	3330-S-2.5	■	■	■
3.00	4.00	6.00	40	3330-S-3.0	■	■	■
3.50	4.00	6.00	40	3330-S-3.5	■	■	■
4.00	5.00	6.00	40	3330-S-4.0	■	■	■
4.50	5.00	6.00	40	3330-S-4.5	■	■	■
5.00	6.00	6.00	40	3330-S-5.0	■	■	■
6.00	7.00	6.00	40	3330-S-6.0	■	■	■

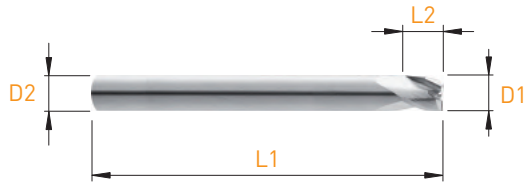

MD VHM HM	$\lambda$ 30°	Sharp Corner		Z=3	
-----------------	---------------	-----------------	--	-----	--

D1 e9	L2	D2 h6	L1	Art. N°	Z	TiAlN	STF
3.00	3.00	3.00	39	<b>3330-3.0</b>	■	■	■
4.00	4.00	4.00	50	<b>3330-4.0</b>	■	■	■
5.00	5.00	5.00	50	<b>3330-5.0</b>	■	■	■
6.00	6.00	6.00	50	<b>3330-6.0</b>	■	■	■
8.00	8.00	8.00	58	<b>3330-8.0</b>	■		
10.00	10.00	10.00	66	<b>3330-10.0</b>	■		
12.00	12.00	12.00	73	<b>3330-12.0</b>	■		

Fraises en bout de finition

Schlicht Schafffräser

Finishing end mills

3330-4

new

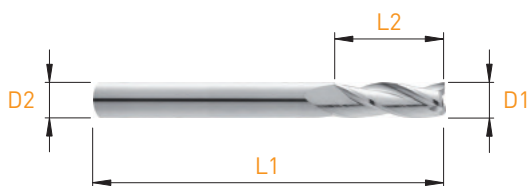

D1 h10	L2	D2 h5	L1	Art. N°	Z	TiAlN	STF
3.00	12.00	6.00	50	3330-4-3.0	■	■	■
4.00	16.00	6.00	50	3330-4-4.0	■	■	■
5.00	20.00	6.00	50	3330-4-5.0	■	■	■
6.00	24.00	6.00	57	3330-4-6.0	■	■	■

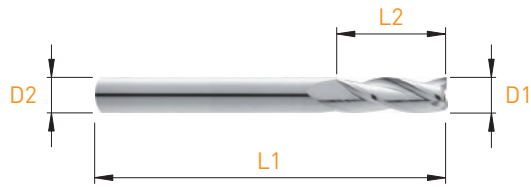

D1 e9	L2	D2 h5	L1	Art. N°	Z	TiAlN	STF
2.00	8.00	2.00	32	<b>3331-2.0</b>	■	■	■
2.50	8.00	2.50	32	<b>3331-2.5</b>	■	■	■
3.00	12.00	3.00	32	<b>3331-3.0</b>	■	■	■
3.50	12.00	3.50	32	<b>3331-3.5</b>	■	■	■
4.00	12.00	4.00	40	<b>3331-4.0</b>	■	■	■
4.50	14.00	4.50	50	<b>3331-4.5</b>	■	■	■
5.00	14.00	5.00	50	<b>3331-5.0</b>	■	■	■
6.00	16.00	6.00	50	<b>3331-6.0</b>	■	■	■



Fraises en bout de finition

Schlicht Schafffräser

Finishing end mills

3336-HA / 3337-HA

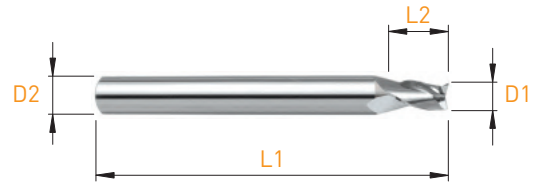
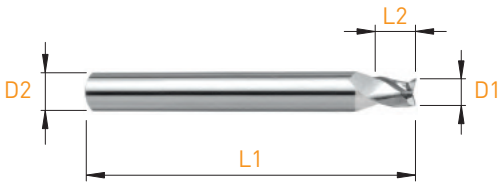

MD VHM HM	$\lambda$ 30°	Sharp Corner		DIN 6527K	Z=3	
-----------------	---------------	-----------------	--	--------------	-----	--

D1 h10	L2	D2 h5	L1	Art. N°	Z	TiAlN	STF
1.50	3.00	6.00	50	3336-HA-1.5	■	■	■
1.80	3.00	6.00	50	3336-HA-1.8	■	■	■
2.00	3.00	6.00	50	3336-HA-2.0	■	■	■
2.50	3.00	6.00	50	3336-HA-2.5	■	■	■
2.80	4.00	6.00	50	3336-HA-2.8	■	■	■
3.00	4.00	6.00	50	3336-HA-3.0	■	■	■
3.50	4.00	6.00	50	3336-HA-3.5	■	■	■
3.80	5.00	6.00	54	3336-HA-3.8	■	■	■
4.00	5.00	6.00	54	3336-HA-4.0	■	■	■
4.50	5.00	6.00	54	3336-HA-4.5	■	■	■
4.80	6.00	6.00	54	3336-HA-4.8	■	■	■
5.00	6.00	6.00	54	3336-HA-5.0	■	■	■
5.50	7.00	6.00	54	3336-HA-5.5	■	■	■
5.80	7.00	6.00	54	3336-HA-5.8	■	■	■
6.00	7.00	6.00	54	3336-HA-6.0	■	■	■

MD VHM HM	$\lambda$ 30°	Sharp Corner		DIN 6527L	Z=3	
-----------------	---------------	-----------------	--	--------------	-----	--

D1 h10	L2	D2 h5	L1	Art. N°	Z	TiAlN	STF
1.50	6.00	6.00	57	3337-HA-1.5	■	■	■
1.80	6.00	6.00	57	3337-HA-1.8	■	■	■
2.00	6.00	6.00	57	3337-HA-2.0	■	■	■
2.50	6.00	6.00	57	3337-HA-2.5	■	■	■
2.80	7.00	6.00	57	3337-HA-2.8	■	■	■
3.00	7.00	6.00	57	3337-HA-3.0	■	■	■
3.50	7.00	6.00	57	3337-HA-3.5	■	■	■
3.80	8.00	6.00	57	3337-HA-3.8	■	■	■
4.00	8.00	6.00	57	3337-HA-4.0	■	■	■
4.50	8.00	6.00	57	3337-HA-4.5	■	■	■
4.80	10.00	6.00	57	3337-HA-4.8	■	■	■
5.00	10.00	6.00	57	3337-HA-5.0	■	■	■
5.50	10.00	6.00	57	3337-HA-5.5	■	■	■
5.80	10.00	6.00	57	3337-HA-5.8	■	■	■
6.00	10.00	6.00	57	3337-HA-6.0	■	■	■

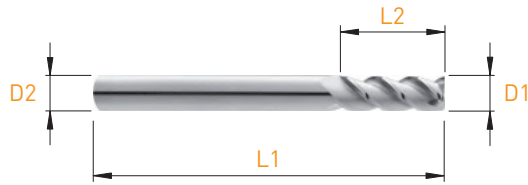

D1 e9	L2	D2 h5	L1	Art. N°	Z	TiAlN	STF
2.00	8.00	2.00	32	<b>3341-2.0</b>	■	■	■
2.50	8.00	2.50	32	<b>3341-2.5</b>	■	■	■
3.00	12.00	3.00	32	<b>3341-3.0</b>	■	■	■
3.50	12.00	3.50	32	<b>3341-3.5</b>	■	■	■
4.00	12.00	4.00	40	<b>3341-4.0</b>	■	■	■
4.50	14.00	4.50	50	<b>3341-4.5</b>	■	■	■
5.00	14.00	5.00	50	<b>3341-5.0</b>	■	■	■
6.00	16.00	6.00	50	<b>3341-6.0</b>	■	■	■

Fraises en bout de finition

Schlicht Schafffräser

Finishing end mills

3345-S

new

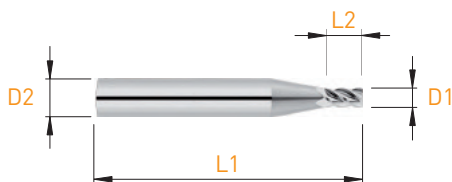

D1 h10	L2	D2 h6	L1	Art. N°	Z	TAIN	STF
0.50	1.00	6.00	40	3345-S-0.5	■	■	■
0.60	1.20	6.00	40	3345-S-0.6	■	■	■
0.70	1.40	6.00	40	3345-S-0.7	■	■	■
0.80	1.60	6.00	40	3345-S-0.8	■	■	■
0.90	1.80	6.00	40	3345-S-0.9	■	■	■
1.00	2.00	6.00	40	3345-S-1.0	■	■	■
1.10	2.20	6.00	40	3345-S-1.1	■	■	■
1.20	2.40	6.00	40	3345-S-1.2	■	■	■
1.30	2.60	6.00	40	3345-S-1.3	■	■	■
1.40	2.80	6.00	40	3345-S-1.4	■	■	■
1.50	3.00	6.00	40	3345-S-1.5	■	■	■
1.60	3.20	6.00	40	3345-S-1.6	■	■	■
1.70	3.40	6.00	40	3345-S-1.7	■	■	■
1.80	3.60	6.00	40	3345-S-1.8	■	■	■
1.90	3.80	6.00	40	3345-S-1.9	■	■	■
2.00	4.00	6.00	40	3345-S-2.0	■	■	■
2.10	4.20	6.00	40	3345-S-2.1	■	■	■
2.20	4.40	6.00	40	3345-S-2.2	■	■	■
2.30	4.60	6.00	40	3345-S-2.3	■	■	■
2.40	4.80	6.00	40	3345-S-2.4	■	■	■
2.50	5.00	6.00	40	3345-S-2.5	■	■	■
2.60	5.20	6.00	40	3345-S-2.6	■	■	■
2.70	5.40	6.00	40	3345-S-2.7	■	■	■
2.80	5.60	6.00	40	3345-S-2.8	■	■	■
2.90	5.80	6.00	40	3345-S-2.9	■	■	■
3.00	6.00	6.00	40	3345-S-3.0	■	■	■
3.50	7.00	6.00	40	3345-S-3.5	■	■	■
4.00	8.00	6.00	40	3345-S-4.0	■	■	■
4.50	9.00	6.00	40	3345-S-4.5	■	■	■
5.00	10.00	6.00	40	3345-S-5.0	■	■	■
6.00	12.00	6.00	40	3345-S-6.0	■	■	■

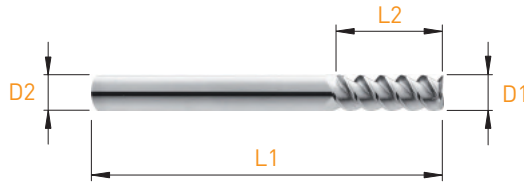

D1 e9	L2	D2 h5	L1	Art. N°	Z	TiAlN	STF
2.00	8.00	2.00	32	<b>3361-2.0</b>	■	■	■
2.50	8.00	2.50	32	<b>3361-2.5</b>	■	■	■
3.00	12.00	3.00	32	<b>3361-3.0</b>	■	■	■
3.50	12.00	3.50	32	<b>3361-3.5</b>	■	■	■
4.00	12.00	4.00	40	<b>3361-4.0</b>	■	■	■
4.50	14.00	4.50	50	<b>3361-4.5</b>	■	■	■
5.00	14.00	5.00	50	<b>3361-5.0</b>	■	■	■
6.00	16.00	6.00	50	<b>3361-6.0</b>	■	■	■

Fraises en bout de finition

Schlicht Schafffräser

Finishing end mills

DHP3336

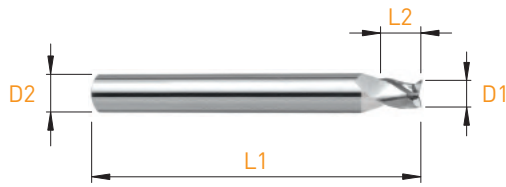

DHP

Denture à pas irrégulier, angle d'hélice progressif  
 Ungleiche Teilung, progressive Drallwinkel  
 Uneven tooth pitch, progressive helix angle

D1 h10	L2	D2 h5	L1	Art. N°	Z	TIALIN	STF
1.00	4.00	6.00	40	DHP3336-1.0	■	■	■
1.50	4.00	6.00	40	DHP3336-1.5	■	■	■
2.00	4.00	6.00	40	DHP3336-2.0	■	■	■
2.50	4.00	6.00	40	DHP3336-2.5	■	■	■
3.00	5.00	6.00	40	DHP3336-3.0	■	■	■
3.50	5.00	6.00	40	DHP3336-3.5	■	■	■
4.00	6.00	6.00	40	DHP3336-4.0	■	■	■
5.00	7.00	6.00	40	DHP3336-5.0	■	■	■
6.00	8.00	6.00	40	DHP3336-6.0	■	■	■

# MICRO-LINE

Fraises en bout de finition

Schlicht Schaftfräser

Finishing end mills

3430



D1 e9	L2	D2 h5	L1	Art. N°	Z	TiAlN	STF
3.00	3.00	3.00	39	3430-3.0	■	■	■
4.00	4.00	4.00	50	3430-4.0	■	■	■
5.00	5.00	5.00	50	3430-5.0	■	■	■
6.00	6.00	6.00	50	3430-6.0	■	■	■

Fraises en bout de finition

Schlicht Schafffräser

Finishing end mills

3431

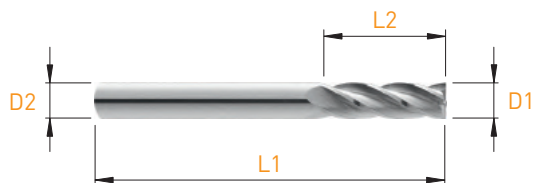

D1 e9	L2	D2 h5	L1	Art. N°	Z	TAIN	STF
2.00	8.00	2.00	32	3431-2.0	■	■	■
2.50	8.00	2.50	32	3431-2.5	■	■	■
3.00	12.00	3.00	32	3431-3.0	■	■	■
3.50	12.00	3.50	32	3431-3.5	■	■	■
4.00	12.00	4.00	40	3431-4.0	■	■	■
4.50	14.00	4.50	50	3431-4.5	■	■	■
5.00	14.00	5.00	50	3431-5.0	■	■	■
6.00	16.00	6.00	50	3431-6.0	■	■	■

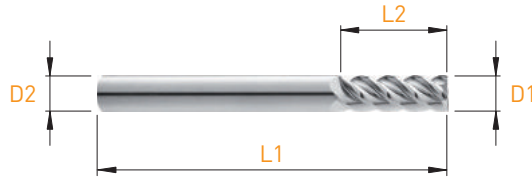

D1 e9	L2	D2 h5	L1	Art. N°	Z	TiAlN	STF
2.00	8.00	2.00	32	3441-2.0	■	■	■
2.50	8.00	2.50	32	3441-2.5	■	■	■
3.00	12.00	3.00	32	3441-3.0	■	■	■
3.50	12.00	3.50	32	3441-3.5	■	■	■
4.00	12.00	4.00	40	3441-4.0	■	■	■
4.50	14.00	4.50	50	3441-4.5	■	■	■
5.00	14.00	5.00	50	3441-5.0	■	■	■
6.00	16.00	6.00	50	3441-6.0	■	■	■



Fraises en bout de finition

Schlicht Schafffräser

Finishing end mills

3445-S

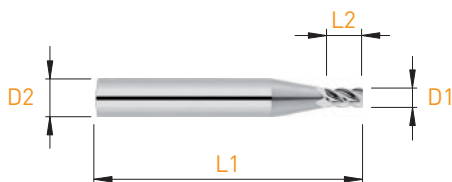

D1 h10	L2	D2 h6	L1	Art. N°	Z	TIAIN	STF
0.50	1.00	6.00	40	3445-S-0.5	■	■	new
0.60	1.20	6.00	40	3445-S-0.6	■	■	new
0.70	1.40	6.00	40	3445-S-0.7	■	■	new
0.80	1.60	6.00	40	3445-S-0.8	■	■	new
0.90	1.80	6.00	40	3445-S-0.9	■	■	new
1.00	2.00	6.00	40	3445-S-1.0	■	■	
1.10	2.20	6.00	40	3445-S-1.1	■	■	new
1.20	2.40	6.00	40	3445-S-1.2	■	■	new
1.30	2.60	6.00	40	3445-S-1.3	■	■	new
1.40	2.80	6.00	40	3445-S-1.4	■	■	new
1.50	3.00	6.00	40	3445-S-1.5	■	■	
1.60	3.20	6.00	40	3445-S-1.6	■	■	new
1.70	3.40	6.00	40	3445-S-1.7	■	■	new
1.80	3.60	6.00	40	3445-S-1.8	■	■	new
1.90	3.80	6.00	40	3445-S-1.9	■	■	new
2.00	4.00	6.00	40	3445-S-2.0	■	■	
2.10	4.20	6.00	40	3445-S-2.1	■	■	new
2.20	4.40	6.00	40	3445-S-2.2	■	■	new
2.30	4.60	6.00	40	3445-S-2.3	■	■	new
2.40	4.80	6.00	40	3445-S-2.4	■	■	new
2.50	5.00	6.00	40	3445-S-2.5	■	■	
2.60	5.20	6.00	40	3445-S-2.6	■	■	new
2.70	5.40	6.00	40	3445-S-2.7	■	■	new
2.80	5.60	6.00	40	3445-S-2.8	■	■	new
2.90	5.80	6.00	40	3445-S-2.9	■	■	new
3.00	6.00	6.00	40	3445-S-3.0	■	■	
3.50	7.00	6.00	40	3445-S-3.5	■	■	
4.00	8.00	6.00	40	3445-S-4.0	■	■	
4.50	9.00	6.00	40	3445-S-4.5	■	■	
5.00	10.00	6.00	40	3445-S-5.0	■	■	
6.00	12.00	6.00	40	3445-S-6.0	■	■	

**new**

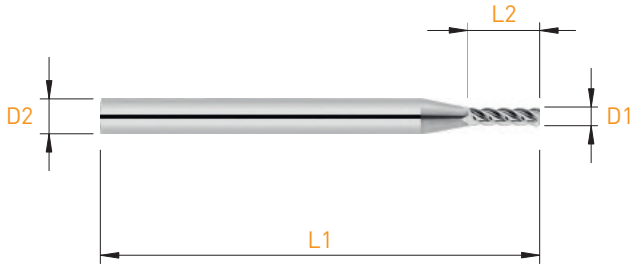

D1 h10	L2	D2 h5	L1	Art. N°	Z	TiAIN	STF
1.00	1.50	6.00	50	3450-1.0	■	■	■
1.50	2.25	6.00	50	3450-1.5	■	■	■
2.00	3.00	6.00	50	3450-2.0	■	■	■
2.50	3.75	6.00	50	3450-2.5	■	■	■
3.00	4.50	6.00	50	3450-3.0	■	■	■
3.50	5.25	6.00	50	3450-3.5	■	■	■
4.00	6.00	6.00	50	3450-4.0	■	■	■
5.00	7.50	6.00	50	3450-5.0	■	■	■
6.00	9.00	6.00	50	3450-6.0	■	■	■

Fraises en bout de finition

Schlicht Schafffräser

Finishing end mills

DHP3436

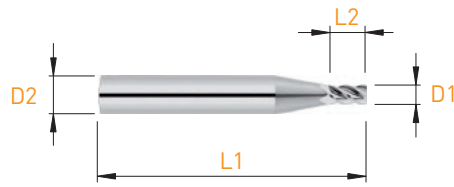

DHP

Denture à pas irrégulier, angle d'hélice progressive  
 Ungleiche Teilung, progressive Drallwinkel  
 Uneven tooth pitch, progressive helix angle

D1 h10	L2	D2 h5	L1	Art. N°	Z	TiAlN	STF
1.00	4.00	6.00	40	DHP3436-1.0	■	■	■
1.50	4.00	6.00	40	DHP3436-1.5	■	■	■
2.00	4.00	6.00	40	DHP3436-2.0	■	■	■
2.50	4.00	6.00	40	DHP3436-2.5	■	■	■
3.00	5.00	6.00	40	DHP3436-3.0	■	■	■
3.50	5.00	6.00	40	DHP3436-3.5	■	■	■
4.00	6.00	6.00	40	DHP3436-4.0	■	■	■
5.00	7.00	6.00	40	DHP3436-5.0	■	■	■
6.00	8.00	6.00	40	DHP3436-6.0	■	■	■

**new**

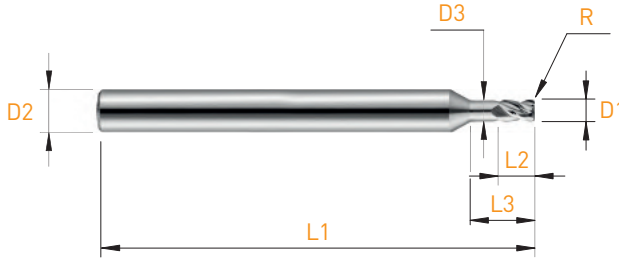

MD VHM HM     $\lambda$  30°    Radius Corner       L3 2.5xD1    Z=4   

D1 h10	R +/- 0.02	L2	L3	D3	D2 h5	L1	Art. N°	Z	TiAlN	STF
3.00	0.50	3.00	7.50	2.95	6.00	57	3439T-2.5X-3.0	■	■	■
3.50	0.50	3.50	8.75	3.45	6.00	57	3439T-2.5X-3.5	■	■	■
4.00	0.50	4.00	10.00	3.95	6.00	57	3439T-2.5X-4.0	■	■	■
4.50	0.50	4.50	11.25	4.45	6.00	57	3439T-2.5X-4.5	■	■	■
5.00	0.50	5.00	12.50	4.95	6.00	57	3439T-2.5X-5.0	■	■	■
5.50	0.50	5.50	13.75	5.45	6.00	57	3439T-2.5X-5.5	■	■	■
6.00	0.50	6.00	15.00	5.95	6.00	57	3439T-2.5X-6.0	■	■	■

Fraises en bout toriques

Torische Schaftfräser

Toric end mills

3439T-4X

new

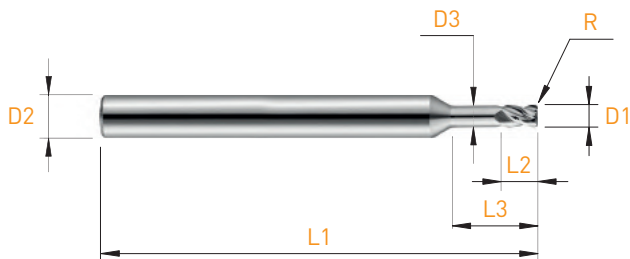

D1 h10	R +/- 0.02	L2	L3	D3	D2 h5	L1	Art. N°	Z	TiAlN	STF
3.00	0.50	3.00	12.00	2.95	6.00	57	3439T-4X-3.0	■	■	■
3.50	0.50	3.50	14.00	3.45	6.00	57	3439T-4X-3.5	■	■	■
4.00	0.50	4.00	16.00	3.95	6.00	57	3439T-4X-4.0	■	■	■
4.50	0.50	4.50	18.00	4.45	6.00	57	3439T-4X-4.5	■	■	■
5.00	0.50	5.00	20.00	4.95	6.00	57	3439T-4X-5.0	■	■	■
5.50	0.50	5.50	22.00	5.45	6.00	57	3439T-4X-5.5	■	■	■
6.00	0.50	6.00	24.00	5.95	6.00	57	3439T-4X-6.0	■	■	■

**new**

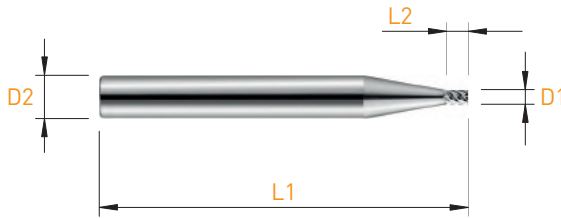

MD VHM HM	$\lambda$ 45°	Sharp Corner		1.5xD1	Z=5	
-----------------	---------------	-----------------	--	--------	-----	--

D1 h10	L2	D2 h5	L1	Art. N°	Z	TiAIN	STF
1.00	1.50	6.00	50	3545-1.0	■	■	■
2.00	3.00	6.00	50	3545-2.0	■	■	■
3.00	4.50	6.00	50	3545-3.0	■	■	■
4.00	6.00	6.00	50	3545-4.0	■	■	■
5.00	7.50	6.00	50	3545-5.0	■	■	■
6.00	9.00	6.00	50	3545-6.0	■	■	■

Fraises en bout de finition

Schlicht Schafffräser

Finishing end mills

35645

new

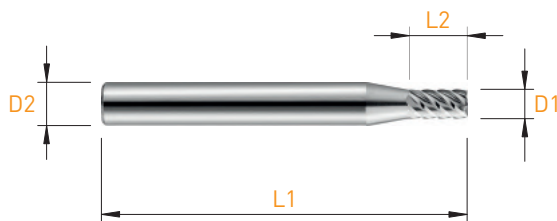
MD  
VHM  
HM $\lambda$  45°Sharp  
CornerZ=4  
Z=5  
Z=6

D1 h10	L2	Z	D2 h5	L1	Art. N°	Z	TiAIN	STF
1.00	2.00	4	6.00	50	35645-1.0	■	■	■
1.50	3.00	5	6.00	50	35645-1.5	■	■	■
2.00	4.00	5	6.00	50	35645-2.0	■	■	■
2.50	5.00	5	6.00	50	35645-2.5	■	■	■
3.00	6.00	5	6.00	50	35645-3.0	■	■	■
3.50	7.00	5	6.00	50	35645-3.5	■	■	■
4.00	8.00	6	6.00	50	35645-4.0	■	■	■
4.50	9.00	6	6.00	50	35645-4.5	■	■	■
5.00	10.00	6	6.00	50	35645-5.0	■	■	■
6.00	12.00	6	6.00	50	35645-6.0	■	■	■

**new**

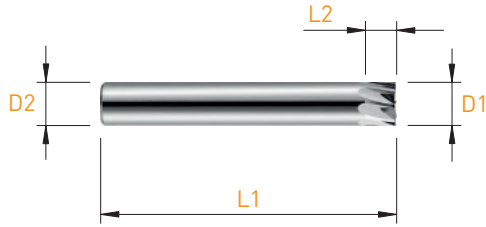

D1 e9	L2	D2 h5	L1	Art. N°	Z	TiAIN	STF
6.00	4.00	6.00	50	3810-0.65-6.0	■	■	■
6.00	6.00	6.00	57	3810-1.0-6.0	■	■	■
6.00	9.00	6.00	57	3810-1.5-6.0	■	■	■



Fraises en bout hémisphériques

Vollradius Schaftfräser

Ball nose end mills

3238

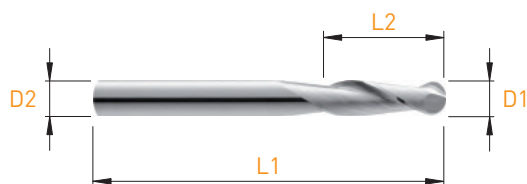

D1 e9	L2	D2 h5	L1	Art. N°	Z	TAIN	STF
2.00	8.00	2.00	32	3238-2.0	■	■	■
2.50	8.00	2.50	32	3238-2.5	■	■	■
3.00	12.00	3.00	32	3238-3.0	■	■	■
3.50	12.00	3.50	32	3238-3.5	■	■	■
4.00	12.00	4.00	40	3238-4.0	■	■	■
4.50	14.00	4.50	50	3238-4.5	■	■	■
5.00	14.00	5.00	50	3238-5.0	■	■	■
6.00	16.00	6.00	50	3238-6.0	■	■	■

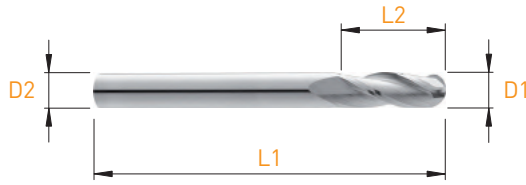

D1 e9	L2	D2 h5	L1	Art. N°	Z	TAIN	STF
2.00	8.00	2.00	32	3338-2.0	■	■	■
2.50	8.00	2.50	32	3338-2.5	■	■	■
3.00	12.00	3.00	32	3338-3.0	■	■	■
3.50	12.00	3.50	32	3338-3.5	■	■	■
4.00	12.00	4.00	40	3338-4.0	■	■	■
4.50	14.00	4.50	50	3338-4.5	■	■	■
5.00	14.00	5.00	50	3338-5.0	■	■	■
6.00	16.00	6.00	50	3338-6.0	■	■	■

Outils pour machine WM 701S

Werkzeuge für Maschine WM 701S

Executions for machine WM 701S



Tous les outils de la gamme MICRO-Line sont réalisables pour la machine WM 701S sur demande.

Alle Werkzeuge aus der MICRO-Line sind machbar für die Maschine WM 701S auf Anfrage.

All tools of MICRO-Line can be produced for the machine WM 701S on request.

Fraises en bout de finition pour machine WM 701S

Schafffräser für Maschine WM 701S

End mills for machine WM 701S

## 701S3371

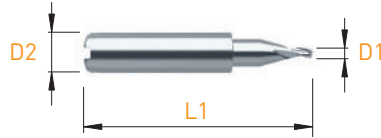

Sharp Corner		1xD1	Z=3	Disponible tous les 0.1 mm Verfügbar jede 0.1 mm Available each 0.1 mm
--------------	--	------	-----	--

D1 +0.005 / -0.010	L2	D2 h5	L1	Art. N°	Z	TiAlN	STF	TiCN	DLC
0.30	0.30	6.00	33	701S3371-1-0.30	■	■	■	■	■
⋮	⋮	⋮	⋮	⋮	⋮	⋮	⋮	⋮	⋮
3.50	3.50	6.00	33	701S3371-1-3.50	■	■	■	■	■

Sharp Corner		2xD1	Z=3	Disponible tous les 0.1 mm Verfügbar jede 0.1 mm Available each 0.1 mm
--------------	--	------	-----	--

D1 +0.005 / -0.010	L2	D2 h5	L1	Art. N°	Z	TiAlN	STF	TiCN	DLC
0.30	0.60	6.00	33	701S3371-2-0.30	■	■	■	■	■
⋮	⋮	⋮	⋮	⋮	⋮	⋮	⋮	⋮	⋮
3.50	7.00	6.00	33	701S3371-2-3.50	■	■	■	■	■

Sharp Corner		3xD1	Z=3	Disponible tous les 0.1 mm Verfügbar jede 0.1 mm Available each 0.1 mm
--------------	--	------	-----	--

D1 +0.005 / -0.010	L2	D2 h5	L1	Art. N°	Z	TiAlN	STF	TiCN	DLC
0.30	0.90	6.00	33	701S3371-3-0.30	■	■	■	■	■
⋮	⋮	⋮	⋮	⋮	⋮	⋮	⋮	⋮	⋮
3.00	9.00	6.00	33	701S3371-3-3.00	■	■	■	■	■

Fraises en bout pour usinage en bout plat

Schafffräser für flache Frontbearbeitung

End mills for flat front machining

3383

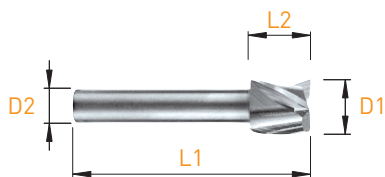

D1 h10	L2	D2 h6	L1	Art. N°	Z
8.00	8.00	6.00	40	<b>3383-8.0</b>	■
10.00	10.00	6.00	40	<b>3383-10.0</b>	■
12.00	12.00	6.00	40	<b>3383-12.0</b>	■

# MICRO-LINE

Fraises en bout avec queue réduite  
 Schafffräser mit reduziertem Schaft  
 End mills with reduced shank

3831 / 3833

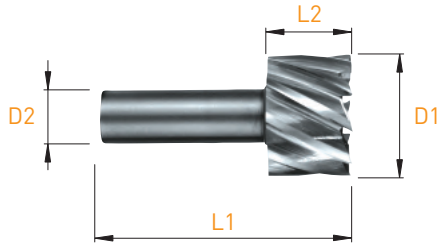

MD VHM HM	$\lambda$ 30°	Sharp Corner		Z=10
-----------------	---------------	-----------------	--	------

D1 h10	L2	D2 h6	L1	Art. N°	Z
16.30	15.00	10.00	45	3831	■
20.30	15.00	10.00	45	3833	■

Fraises à angler

Kegelsenker

Chamfering tools

3611

new



MD VHM HM	$\lambda^{0^\circ}$		Z=3	60°
-----------------	---------------------	--	-----	-----

D1 +0.005 / -0.010	L2	D2 h4	L1	d	Art. N°	Z	TIALIN	STF
0.50	3.00	3.00	39	0.10	3611-0.5	■	■	■
0.60	3.00	3.00	39	0.10	3611-0.6	■	■	■
0.70	3.00	3.00	39	0.10	3611-0.7	■	■	■
0.80	3.00	3.00	39	0.10	3611-0.8	■	■	■
0.90	3.00	3.00	39	0.10	3611-0.9	■	■	■
1.00	3.00	3.00	39	0.10	3611-1.0	■	■	■
1.50	4.50	3.00	39	0.10	3611-1.5	■	■	■
2.00	6.00	3.00	39	0.10	3611-2.0	■	■	■
2.50	7.50	3.00	39	0.10	3611-2.5	■	■	■
3.00	-	3.00	39	0.10	3611-3.0	■	■	■



MD VHM HM	$\lambda^{0^\circ}$		Z=3	90°
-----------------	---------------------	--	-----	-----

D1	L2	D2 h4	L1	d	Art. N°	Z	TiAlN	STF
0.50	3.00	3.00	39	0.10	<b>3911-0.5</b>	■	■	■
0.60	3.00	3.00	39	0.10	<b>3911-0.6</b>	■	■	■
0.70	3.00	3.00	39	0.10	<b>3911-0.7</b>	■	■	■
0.80	3.00	3.00	39	0.10	<b>3911-0.8</b>	■	■	■
0.90	3.00	3.00	39	0.10	<b>3911-0.9</b>	■	■	■
1.00	3.00	3.00	39	0.10	<b>3911-1.0</b>	■	■	■
1.50	4.50	3.00	39	0.10	<b>3911-1.5</b>	■	■	■
2.00	6.00	3.00	39	0.10	<b>3911-2.0</b>	■	■	■
2.50	7.50	3.00	39	0.10	<b>3911-2.5</b>	■	■	■
3.00	-	3.00	39	0.10	<b>3911-3.0</b>	■	■	■



Fraises à angler

Kegelsenker

Chamfering tools

1901 / 3901

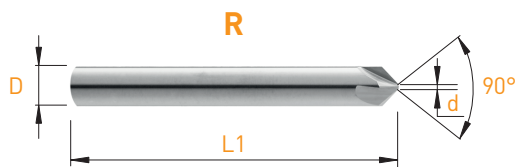



MD VHM HM	$\lambda^{0^\circ}$		Z=4	90°	L		R		
D Ø3h4 Ø6h5 Ø8h6	d	L1	Art. N°	Z	Art. N°	Z	TiAlN	STF	
3.00	0.30	39	1901-3.0	■	3901-3.0	■	■	■	
6.00	0.70	50	1901-6.0	■	3901-6.0	■	■	■	
8.00	1.20	59	1901-8.0	■	3901-8.0	■	■	■	

Fraises à graver

Gravierfräser

Engraving mills

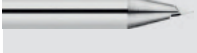
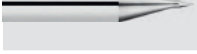
Paramètres de coupe indicatif Empfohlene Schnittwerte Standard machining data					14.99
	A	Plat [E] / Rayon [r] Fläche [E] / Radius [r] Flat [E] / Radius [r]	D	Type Typ Type	Page Seite Page
	20° / 30° / 35° / 40° 45° / 50° / 55° / 60° 65° / 70° / 90° / 120°	0.05-0.30 0.05-0.10 / every 0.01 0.10-0.30 / every 0.05	Ø3h4 Ø6h5	E100-P	14.100 <b>new</b>
	20° / 30° / 35° / 40° 45° / 50° / 55° / 60° 65° / 70° / 90°	0.02-0.30 0.02-0.10 / every 0.01 0.10-0.30 / every 0.05	Ø3h4	E300-P	14.101
	20° / 30° / 35° / 40° 45° / 50° / 55° / 60° 65° / 70° / 90°	0.04-0.30 0.04-0.10 / every 0.01 0.10-0.30 / every 0.05	Ø3h4	E300-R	14.102
	20° / 30° / 35° / 40° 45° / 50° / 55° / 60° 65° / 70° / 90°	0.04-0.30 0.04-0.10 / every 0.01 0.10-0.30 / every 0.05	Ø3h4	E900-P	14.103

## Fraises à graver

## Gravierfräser

## Engraving mills

## Paramètres de coupe indicatifs

## Empfohlene Schnittwerte

## Standard machining data

Matière Werkstoff Material	n	Vf	Z	TiAlN	STF	TiCN	DLC
	[tr/min]	[mm/min]					
Acier de décolletage Automatenstahl Free-cutting steel (P)	20 - 50'000	100 - 180	-	***	***	**	-
Acier Stahl < 600 N/mm <sup>2</sup> (P)	20 - 50'000	100 - 180	-	***	***	**	-
Acier Stahl < 800 N/mm <sup>2</sup> (P)	20 - 50'000	100 - 180	-	***	***	**	-
Acier Stahl > 800 N/mm <sup>2</sup> (P)	20 - 50'000	100 - 150	-	***	***	**	-
Acier trempé Gehärteter Stahl -55HRC (H)	20 - 50'000	-	-	***	***	*	-
Acier trempé Gehärteter Stahl +55HRC (H)	20 - 50'00	-	-	***	***	*	-
Inox Rostfreistahl Stainless steel (M)	20 - 50'000	100 - 170	-	***	***	**	-
Aluminium (N)	20 - 50'000	100 - 250	***	**	**	*	***
Cuivre, laiton, bronze Kupfer, Messing, Bronze Copper, brass, bronze (N)	20 - 50'000	70 - 150	***	**	**	**	***
Matière synthétique Synthetisches Material Synthetic material (N)	20 - 50'000	100 - 200	***	**	**	**	***
Métaux précieux Edelmetalle Precious metals (N)	20 - 50'000	100 - 200	***	**	**	**	***
Titane Titan Titanium (S)	20 - 50'000	70 - 150	-	***	***	**	-
Alliage de nickel Nickel-Legierung Nickel alloy (S)	20 - 50'000	80 - 180	-	***	***	**	-
Matière exotique Exotisches material Exotic material (O)	20 - 50'000	80 - 180	*	***	***	**	***

Avec revêtement, augmenter les valeurs de 20-30%

Mit Beschichtung, Daten um 20-30% erhöhen

With coating, increase data by 20-30%

\* Bien / Gut / Good

\*\* Très bien / Sehr Gut / Very good

\*\*\* Excellent / Ausgezeichnet / Excellent

# MICRO-LINE

Fraises à graver avec plat

Gravierfräser mit Fläche

Engraving mills with flat

E100-P

new

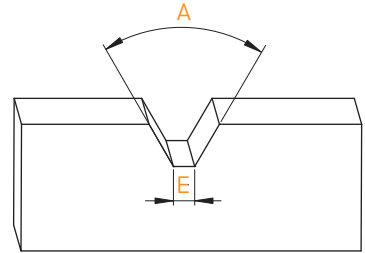
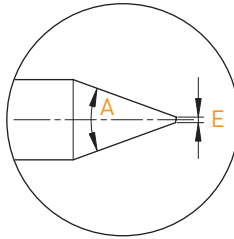

MD  
VHM  
HM

A	E	L2	D2 h4 Ø3.0 h5 Ø6.0	L1	Art. N°	Z	TiAlN	STF	TiCN	DLC
20°	0.05-0.10* / 0.10-0.30 **	5.20	3.00	33	E120-P-_(E)	■	■	■	■	■
30°	0.05-0.10* / 0.10-0.30 **	5.20	3.00	33	E130-P-_(E)	■	■	■	■	■
35°	0.05-0.10* / 0.10-0.30 **	5.20	3.00	33	E135-P-_(E)	■	■	■	■	■
40°	0.05-0.10* / 0.10-0.30 **	6.00	3.00	33	E140-P-_(E)	■	■	■	■	■
45°	0.05-0.10* / 0.10-0.30 **	6.00	3.00	33	E145-P-_(E)	■	■	■	■	■
50°	0.05-0.10* / 0.10-0.30 **	6.00	3.00	33	E150-P-_(E)	■	■	■	■	■
55°	0.05-0.10* / 0.10-0.30 **	6.00	3.00	33	E155-P-_(E)	■	■	■	■	■
60°	0.05-0.10* / 0.10-0.30 **	8.00	3.00	33	E160-P-_(E)	■	■	■	■	■
65°	0.05-0.10* / 0.10-0.30 **	8.00	3.00	33	E165-P-_(E)	■	■	■	■	■
70°	0.05-0.10* / 0.10-0.30 **	8.00	3.00	33	E170-P-_(E)	■	■	■	■	■
90°	0.05-0.10* / 0.10-0.30 **	8.00	3.00	33	E190-P-_(E)	■	■	■	■	■
120°	0.05-0.10* / 0.10-0.30 **	8.00	3.00	33	E1120-P-_(E)	■	■	■	■	■
30°	0.05-0.10* / 0.10-0.30 **	12.00	6.00	40	E130-6-P-_(E)	■	■	■	■	■
40°	0.05-0.10* / 0.10-0.30 **	12.00	6.00	40	E140-6-P-_(E)	■	■	■	■	■

\* tous les 0.01 mm  
alle 0.01 mm  
every 0.01 mm

\*\* tous les 0.05 mm  
alle 0.05 mm  
every 0.05 mm

Fraises à graver avec plat

Gravierfräser mit Fläche

Engraving mills with flat

E300-P

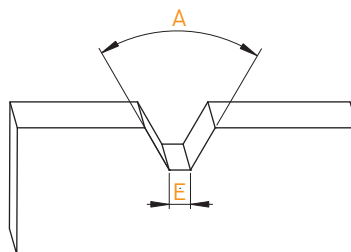
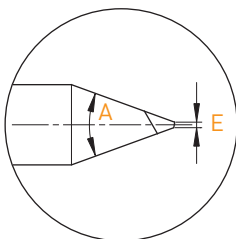

MD  
VHM  
HM

A	E	D h4	L1	Art. N°	Z	TiAIN	STF	TiCN	DLC
20°	0.02-0.10* / 0.10-0.30**	3.00	33	E320-P-_(E)	■	■	■	■	■
30°	0.02-0.10* / 0.10-0.30**	3.00	33	E330-P-_(E)	■	■	■	■	■
35°	0.02-0.10* / 0.10-0.30**	3.00	33	E335-P-_(E)	■	■	■	■	■
40°	0.02-0.10* / 0.10-0.30**	3.00	33	E340-P-_(E)	■	■	■	■	■
45°	0.02-0.10* / 0.10-0.30**	3.00	33	E345-P-_(E)	■	■	■	■	■
50°	0.02-0.10* / 0.10-0.30**	3.00	33	E350-P-_(E)	■	■	■	■	■
55°	0.02-0.10* / 0.10-0.30**	3.00	33	E355-P-_(E)	■	■	■	■	■
60°	0.02-0.10* / 0.10-0.30**	3.00	33	E360-P-_(E)	■	■	■	■	■
65°	0.02-0.10* / 0.10-0.30**	3.00	33	E365-P-_(E)	■	■	■	■	■
70°	0.02-0.10* / 0.10-0.30**	3.00	33	E370-P-_(E)	■	■	■	■	■
90°	0.02-0.10* / 0.10-0.30**	3.00	33	E390-P-_(E)	■	■	■	■	■

\* tous les 0.01 mm  
alle 0.01 mm  
every 0.01 mm

\*\* tous les 0.05 mm  
alle 0.05 mm  
every 0.05 mm

# MICRO-LINE

Fraises à graver à rayon

Gravierfräser mit Radius

Engraving mills with radius

E300-R

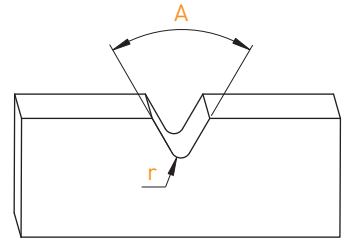
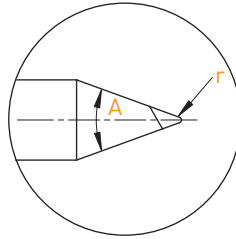

MD  
VHM  
HM

A	r	D h4	L1	Art. N°	N	TiAlN	STF	TiCN	DLC
20°	0.04-0.10* / 0.10-0.30**	3.00	33	E320-R_(r)	■	■	■	■	■
30°	0.04-0.10* / 0.10-0.30**	3.00	33	E330-R_(r)	■	■	■	■	■
35°	0.04-0.10* / 0.10-0.30**	3.00	33	E335-R_(r)	■	■	■	■	■
40°	0.04-0.10* / 0.10-0.30**	3.00	33	E340-R_(r)	■	■	■	■	■
45°	0.04-0.10* / 0.10-0.30**	3.00	33	E345-R_(r)	■	■	■	■	■
50°	0.04-0.10* / 0.10-0.30**	3.00	33	E350-R_(r)	■	■	■	■	■
55°	0.04-0.10* / 0.10-0.30**	3.00	33	E355-R_(r)	■	■	■	■	■
60°	0.04-0.10* / 0.10-0.30**	3.00	33	E360-R_(r)	■	■	■	■	■
65°	0.04-0.10* / 0.10-0.30**	3.00	33	E365-R_(r)	■	■	■	■	■
70°	0.04-0.10* / 0.10-0.30**	3.00	33	E370-R_(r)	■	■	■	■	■
90°	0.04-0.10* / 0.10-0.30**	3.00	33	E390-R_(r)	■	■	■	■	■

\* tous les 0.01 mm  
alle 0.01 mm  
every 0.01 mm

\*\* tous les 0.05 mm  
alle 0.05 mm  
every 0.05 mm

Fraises à graver renforcées

Verstärkte Gravierfräser

Reinforced engraving mills

E900-P

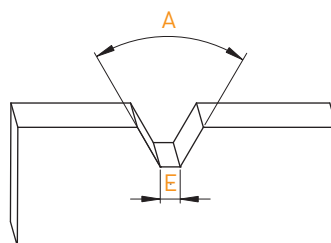
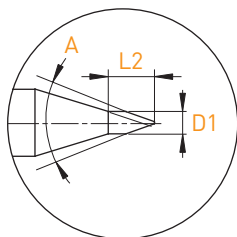

MD  
VHM  
HM

A	E	D1	L2	D <sub>h4</sub>	L1	Art. N°	Z	TiAIN	STF	TiCN	DLC
20°	0.04-0.10* / 0.10-0.30**	0.60	1.80	3.00	33	E920-P-_(E)	■	■	■	■	■
30°	0.04-0.10* / 0.10-0.30**	0.60	1.80	3.00	33	E930-P-_(E)	■	■	■	■	■
35°	0.04-0.10* / 0.10-0.30**	0.60	1.80	3.00	33	E935-P-_(E)	■	■	■	■	■
40°	0.04-0.10* / 0.10-0.30**	0.60	1.80	3.00	33	E940-P-_(E)	■	■	■	■	■
45°	0.04-0.10* / 0.10-0.30**	1.00	1.80	3.00	33	E945-P-_(E)	■	■	■	■	■
50°	0.04-0.10* / 0.10-0.30**	1.00	2.00	3.00	33	E950-P-_(E)	■	■	■	■	■
55°	0.04-0.10* / 0.10-0.30**	1.00	2.00	3.00	33	E955-P-_(E)	■	■	■	■	■
60°	0.04-0.10* / 0.10-0.30**	1.20	2.00	3.00	33	E960-P-_(E)	■	■	■	■	■
65°	0.04-0.10* / 0.10-0.30**	1.20	2.00	3.00	33	E965-P-_(E)	■	■	■	■	■
70°	0.04-0.10* / 0.10-0.30**	1.20	2.00	3.00	33	E970-P-_(E)	■	■	■	■	■
90°	0.04-0.10* / 0.10-0.30**	1.20	2.00	3.00	33	E990-P-_(E)	■	■	■	■	■

\* tous les 0.01 mm  
alle 0.01 mm  
every 0.01 mm

\*\* tous les 0.05 mm  
alle 0.05 mm  
every 0.05 mm

Paramètres de coupe indicatif  
Empfohlene Schnittwerte  
Standard machining data

**Micro-forets et centreurs**  
**Mikrobohrer und Zentrierbohrer**  
**Micro drills and centering drills**

Point angle	$\lambda$	L2	D1	D2	Type	Page
60°	25°	Div.	Ø 2.00 - 6.00	D1 = D2	2680-60	14.107
90°	25°	Div.	Ø 0.50 - 20.00	Ø 2.0 - 20.0	2680-90	14.108
90°	25°	Div.	Ø 2.00 - 16.00	D1 = D2	1680-90	14.108
120°	25°	Div.	Ø 0.50 - 20.00	Ø 2.0 - 20.0	2680-120	14.109
120°	25°	Div.	Ø 2.00 - 12.00	D1 = D2	1680-120	14.109

**Micro-forets de préperçage**  
**Mikro Pilotbohrer**  
**Micro pilot drill**

Z	Point angle	$\lambda$	L2	D1	D2	Type	Page
Z2	90°	25° - 32°	Div.	Ø 0.50 - 3.00	Ø2h5 Ø3h4	2690	14.110
Z2	130°	30°	~ 2 x D1	Ø 0.10 - 2.00	Ø3h6	2020	14.115

**Micro-forets avec affûtage à facettes**  
**Mikrobohrer mit Facettenschliff**  
**Micro drills with faceted drill point**

Z	Point angle	$\lambda$	L2	D1	D2	Type	Page
Z2	118°	25°	~ 5-10 x D1	Ø 0.50 - 6.00	D1 = D2	1010	14.111
Z2	118°	25°/35°	~ 5-10 x D1	Ø 0.50 - 6.00	D1 = D2	2010	14.112
Z2	120°	30°	~ 2 x D1	Ø 0.80 - 2.00	Ø 2h6	2011	14.113
Z2	120°	24°	~ 3 x D1	Ø 0.50 - 2.40	Ø 1.5 - 3.0 h6	2012	14.113
Z2	120°	35°	~ 8 x D1	Ø 0.40 - 1.90	Ø 1.0 - 2.0 h6	2013	14.114
Z2	120°	30°	~ 12 x D1	Ø 0.50 - 1.95	Ø 1.5 - 2.0 h6	2014	14.114
Z2	130°	35°	6 x D1	Ø 0.10 - 3.00	Ø3h6	2023	14.117
Z2	130°	35°	12 x D1	Ø 0.20 - 2.00	Ø3h6	2026	14.120
Z3	140°	35°	5 x D1	Ø 0.20 - 2.99	Ø3h6	2030	14.122



Forets à centrer NC

NC-Zentrierbohrer

NC centering drills

Paramètres de coupe indicatifs

Empfohlene Schnittwerte

Standard machining data

Matière Werkstoff Material	VC	f	Z	TAIN	STF
	[m/min]	[mm]			
Acier de décolletage Automatenstahl Free-cutting steel (P)	60	D1/55	**	***	***
Acier Stahl Steel (< 600 N/mm²) (P)	55	D1/55	**	***	***
Acier Stahl Steel (< 800 N/mm²) (P)	55	D1/55	**	***	***
Acier Stahl Steel (> 800 N/mm²) (P)	55	D1/55	**	***	***
Acier trempé Gehärteter Stahl -55HRC Hardened steel (H)	10	D1/100	-	***	***
Acier trempé Gehärteter Stahl +55HRC Hardened steel (H)	-	-	-	-	-
Inox Rostfreistahl Stainless steel (M)	30	D1/85	**	***	***
Aluminium (N)	100 - 180	D1/50	***	**	**
Cuivre, laiton, bronze Kupfer, Messing, Bronze Copper, brass, bronze (N)	60 - 90	D1/60	***	**	**
Matière synthétique Synthetisches Material Synthetic material (N)	350 - 700	D1/60	***	**	**
Métaux précieux Edelmetalle Precious metals (N)	50 - 80	D1/100	***	**	**
Titane Titan Titanium (S)	30	D1/115	**	***	***
Alliage de nickel Nickel-Legierung Nickel alloy (S)	15 - 20	D1/120	**	***	***
Matière exotique Exotisches material Exotic material (O)	10	D1/100	**	***	***

Avec revêtement, augmenter les valeurs de 20-30%

Mit Beschichtung, Daten um 20-30% erhöhen

With coating, increase data by 20-30%

\* Bien / Gut / Good

\*\* Très bien / Sehr Gut / Very good

\*\*\* Excellent / Ausgezeichnet / Excellent

Matière Werkstoff Material		VC	f	Débouillage
		(m/min)	(mm)	
Acier de décolletage Automatenstahl Free-cutting steel	<b>P</b>	60 - 90	D1/70	1.5xØ
Acier Stahl Steel	< 600 N/mm <sup>2</sup> <b>P</b>	50 - 80	D1/70	1.5xØ
Acier Stahl Steel	< 800 N/mm <sup>2</sup> <b>P</b>	50 - 80	D1/70	1.5xØ
Acier Stahl Steel	> 800 N/mm <sup>2</sup> <b>P</b>	50 - 80	D1/70	1.5xØ
Acier trempé Gehärteter Stahl Hardened steel	-55HRC <b>H</b>	-	-	-
Acier trempé Gehärteter Stahl Hardened steel	+55HRC <b>H</b>	-	-	-
Inox Rostfreistahl Stainless steel	<b>M</b>	20 - 30	D1/70	3xØ
Aluminium	<b>N</b>	100 - 180	D1/40	2xØ
Cuivre, laiton, bronze Kupfer, Messing, Bronze Copper, brass, bronze	<b>N</b>	50 - 85	D1/120	1xØ
Matière synthétique Synthetisches Material Synthetic material	<b>N</b>	350 - 750	D1/40	2xØ
Métaux précieux Edelmetalle Precious metals	<b>N</b>	60 - 90	D1/100	0.85xØ
Titane Titan Titanium	<b>S</b>	20 - 40	D1/120	1.3xØ
Alliage de nickel Nickel-Legierung Nickel alloy	<b>S</b>	20	D1/120	1xØ
Matière exotique Exotisches material Exotic material	<b>O</b>	5 - 10	D1/100	1xØ

Avec revêtement, augmenter les valeurs de 20-30%

Mit Beschichtung, Daten um 20-30% erhöhen

With coating, increase data by 20-30%

Centreurs NC

NC-Zentrierbohrer

NC centering drills

2680-60

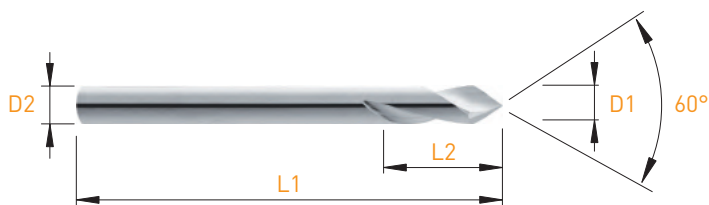

MD VHM HM	$\lambda^{25^\circ}$	60°
-----------------	----------------------	-----

D1 h6	L2	D2 h5	L1	Art. N°	Z	TiAlN	STF
2.00	8.00	2.00	39	2680-2.00-60	■	■	■
3.00	10.00	3.00	39	2680-3.00-60	■	■	■
4.00	12.00	4.00	50	2680-4.00-60	■	■	■
5.00	14.00	5.00	50	2680-5.00-60	■	■	■
6.00	16.00	6.00	50	2680-6.00-60	■	■	■

# MICRO-LINE

Centreurs NC  
 NC-Zentrierbohrer  
 NC centering drills

1680-90° / 2680-90°

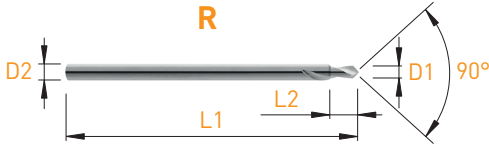

MD VHM HM	$\lambda$		R					
	25°	90°	D1 h <sub>6</sub>	L2	D2 h <sub>5</sub>	L1	Art. N°	Z
			0.50	1.50	2.00	39	2680-0.50-90	■
			0.60	1.50	2.00	39	2680-0.60-90	■
			0.70	1.50	2.00	39	2680-0.70-90	■
			0.80	1.50	2.00	39	2680-0.80-90	■
			0.90	1.50	2.00	39	2680-0.90-90	■
			1.00	3.00	2.00	39	2680-1.00-90	■
			1.10	3.00	2.00	39	2680-1.10-90	■
			1.20	3.00	2.00	39	2680-1.20-90	■
			1.30	3.00	2.00	39	2680-1.30-90	■
			1.40	3.00	2.00	39	2680-1.40-90	■
			1.50	4.00	2.00	39	2680-1.50-90	■
			1.60	4.00	2.00	39	2680-1.60-90	■
			1.70	4.00	2.00	39	2680-1.70-90	■
			1.80	4.00	2.00	39	2680-1.80-90	■
			1.90	4.00	2.00	39	2680-1.90-90	■

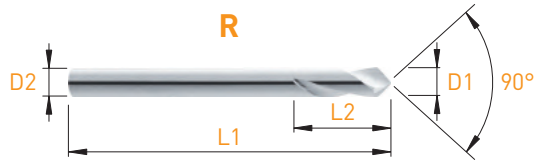

MD VHM HM	$\lambda$		L				R				HSS	R		
	25°	90°	D1	L2	D2 h <sub>6</sub>	L1	Art. N°	Z	Art. N°	Z		TiAIN	STF	Art. N°
			2.00	8.00	2.00	39	1680-2.00-90	■	2680-2.00-90	■	■	■	-	
			2.50	8.00	2.50	39	1680-2.50-90	■	2680-2.50-90	■	■	■	-	
			3.00	10.00	3.00	39	1680-3.00-90	■	2680-3.00-90	■	■	■	2680-3.00-90-HSS	■
			4.00	12.00	4.00	50	1680-4.00-90	■	2680-4.00-90	■	■	■	2680-4.00-90-HSS	■
			5.00	15.00	5.00	50	1680-5.00-90	■	2680-5.00-90	■	■	■	2680-5.00-90-HSS	■
			6.00	16.00	6.00	57	1680-6.00-90	■	2680-6.00-90	■	■	■	2680-6.00-90-HSS	■
			8.00	20.00	8.00	63	1680-8.00-90	■	2680-8.00-90	■			2680-8.00-90-HSS	■
			10.00	22.00	10.00	72	1680-10.00-90	■	2680-10.00-90	■			2680-10.00-90-HSS	■
			12.00	24.00	12.00	73	1680-12.00-90	■	2680-12.00-90	■			2680-12.00-90-HSS	■
			16.00	26.00	16.00	82	1680-16.00-90	■	2680-16.00-90	■			-	
			20.00	30.00	20.00	92	-		2680-20.00-90	■			-	

Centreurs NC  
 NC-Zentrierbohrer  
 NC centering drills

1680-120° / 2680-120°

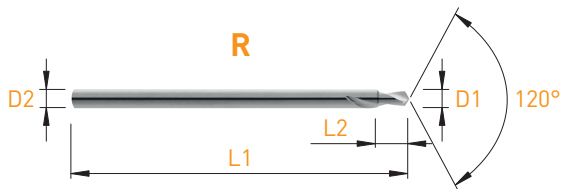

MD VHM HM	$\lambda$		R		
	25°	120°			
D1 h6	L2	D2 h5	L1	Art. N°	Z
0.50	1.50	2.00	39	2680-0.50-120	■
0.60	1.50	2.00	39	2680-0.60-120	■
0.70	1.50	2.00	39	2680-0.70-120	■
0.80	1.50	2.00	39	2680-0.80-120	■
0.90	1.50	2.00	39	2680-0.90-120	■
1.00	3.00	2.00	39	2680-1.00-120	■
1.10	3.00	2.00	39	2680-1.10-120	■
1.20	3.00	2.00	39	2680-1.20-120	■
1.30	3.00	2.00	39	2680-1.30-120	■
1.40	3.00	2.00	39	2680-1.40-120	■
1.50	4.00	2.00	39	2680-1.50-120	■
1.60	4.00	2.00	39	2680-1.60-120	■
1.70	4.00	2.00	39	2680-1.70-120	■
1.80	4.00	2.00	39	2680-1.80-120	■
1.90	4.00	2.00	39	2680-1.90-120	■

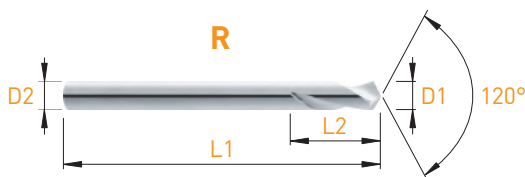

MD VHM HM	$\lambda$		L		R				
	25°	120°							
D1	L2	D2 h6	L1	Art. N°	Z	Art. N°	Z	TiAlN	STF
2.00	8.00	2.00	39	1680-2.00-120	■	2680-2.00-120	■	■	■
2.50	8.00	2.50	39	1680-2.50-120	■	2680-2.50-120	■	■	■
3.00	10.00	3.00	39	1680-3.00-120	■	2680-3.00-120	■	■	■
4.00	12.00	4.00	50	1680-4.00-120	■	2680-4.00-120	■	■	■
5.00	15.00	5.00	50	1680-5.00-120	■	2680-5.00-120	■	■	■
6.00	16.00	6.00	57	1680-6.00-120	■	2680-6.00-120	■	■	■
8.00	20.00	8.00	63	1680-8.00-120	■	2680-8.00-120	■		
10.00	22.00	10.00	72	1680-10.00-120	■	2680-10.00-120	■		
12.00	24.00	12.00	73	1680-12.00-120	■	2680-12.00-120	■		
16.00	26.00	16.00	82	-		2680-16.00-120	■		
20.00	30.00	20.00	92	-		2680-20.00-120	■		

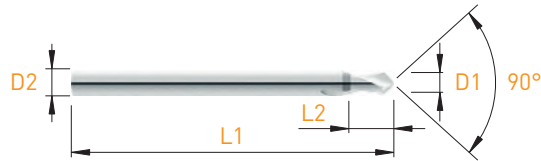

MD VHM HM	* $\lambda$			Art. N°	Z	TiAlN	STF
	$\lambda$ 32°	$\lambda$ 25°	90°				
D1 h5	L2	D2 h5	L1				
0.50*	2.50	2.00	39	2690-0.50	■		
0.60*	2.50	2.00	39	2690-0.60	■		
0.70*	2.50	2.00	39	2690-0.70	■		
0.80*	2.50	2.00	39	2690-0.80	■		
0.90*	2.50	2.00	39	2690-0.90	■		
1.00	3.00	2.00	39	2690-1.00	■		
1.10	3.00	2.00	39	2690-1.10	■		
1.20	3.00	2.00	39	2690-1.20	■		
1.30	3.00	2.00	39	2690-1.30	■		
1.40	3.00	2.00	39	2690-1.40	■		
1.50	3.50	2.00	39	2690-1.50	■		
1.60	3.50	2.00	39	2690-1.60	■		
1.70	3.50	2.00	39	2690-1.70	■		
1.80	3.50	2.00	39	2690-1.80	■		
1.90	3.50	2.00	39	2690-1.90	■		
2.00	-	2.00	39	2690-2.00	■	■	■
2.10	4.00	3.00	39	2690-2.10	■	■	■
2.20	4.00	3.00	39	2690-2.20	■	■	■
2.30	4.00	3.00	39	2690-2.30	■	■	■
2.40	4.00	3.00	39	2690-2.40	■	■	■
2.50	4.00	3.00	39	2690-2.50	■	■	■
2.60	4.00	3.00	39	2690-2.60	■	■	■
2.70	4.00	3.00	39	2690-2.70	■	■	■
2.80	4.00	3.00	39	2690-2.80	■	■	■
2.90	4.00	3.00	39	2690-2.90	■	■	■
3.00	-	3.00	50	2690-3.00	■	■	■

Forets cylindriques

Zylindrische Bohrer

Cylindrical drills

Coupe à gauche

Linksschneidend

Left hand cut

1010

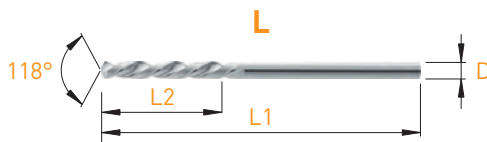

MD  
VHM  
HM

$\lambda$  25°

Z=2



D h6	L1	L2	Art. N°	Z
0.50	30	5.00	1010-0.50	■
0.55	30	5.00	1010-0.55	■
0.60	30	5.00	1010-0.60	■
0.65	30	6.00	1010-0.65	■
0.70	30	6.00	1010-0.70	■
0.75	30	8.00	1010-0.75	■
0.80	30	8.00	1010-0.80	■
0.85	30	9.00	1010-0.85	■
0.90	30	9.00	1010-0.90	■
0.95	30	10.00	1010-0.95	■
1.00	30	10.00	1010-1.00	■
1.05	30	10.00	1010-1.05	■
1.10	30	10.00	1010-1.10	■
1.15	30	12.00	1010-1.15	■
1.20	30	12.00	1010-1.20	■
1.25	30	12.00	1010-1.25	■
1.30	30	12.00	1010-1.30	■
1.35	30	12.00	1010-1.35	■
1.40	30	12.00	1010-1.40	■
1.45	30	12.00	1010-1.45	■
1.50	30	12.00	1010-1.50	■
1.55	40	16.00	1010-1.55	■
1.60	40	16.00	1010-1.60	■
1.65	40	16.00	1010-1.65	■
1.70	40	16.00	1010-1.70	■
1.75	40	16.00	1010-1.75	■
1.80	40	16.00	1010-1.80	■
1.85	40	16.00	1010-1.85	■
1.90	40	16.00	1010-1.90	■
1.95	40	16.00	1010-1.95	■
2.00	40	16.00	1010-2.00	■
2.05	40	18.00	1010-2.05	■
2.10	40	18.00	1010-2.10	■
2.15	40	18.00	1010-2.15	■
2.20	40	18.00	1010-2.20	■
2.25	40	18.00	1010-2.25	■
2.30	40	18.00	1010-2.30	■
2.35	40	18.00	1010-2.35	■
2.40	40	18.00	1010-2.40	■
2.45	40	18.00	1010-2.45	■
2.50	40	18.00	1010-2.50	■

D h6	L1	L2	Art. N°	Z
2.55	45	18.00	1010-2.55	■
2.60	45	18.00	1010-2.60	■
2.65	45	18.00	1010-2.65	■
2.70	45	18.00	1010-2.70	■
2.75	45	18.00	1010-2.75	■
2.80	45	18.00	1010-2.80	■
2.85	45	18.00	1010-2.85	■
2.90	45	18.00	1010-2.90	■
2.95	45	18.00	1010-2.95	■
3.00	45	18.00	1010-3.00	■
3.10	50	20.00	1010-3.10	■
3.20	50	20.00	1010-3.20	■
3.30	50	20.00	1010-3.30	■
3.40	50	20.00	1010-3.40	■
3.50	50	20.00	1010-3.50	■
3.60	50	20.00	1010-3.60	■
3.70	50	20.00	1010-3.70	■
3.80	50	20.00	1010-3.80	■
3.90	50	20.00	1010-3.90	■
4.00	50	20.00	1010-4.00	■
4.10	50	25.00	1010-4.10	■
4.20	50	25.00	1010-4.20	■
4.30	50	25.00	1010-4.30	■
4.40	50	25.00	1010-4.40	■
4.50	50	25.00	1010-4.50	■
4.60	50	25.00	1010-4.60	■
4.70	50	25.00	1010-4.70	■
4.80	50	25.00	1010-4.80	■
4.90	50	25.00	1010-4.90	■
5.00	50	25.00	1010-5.00	■
5.10	50	25.00	1010-5.10	■
5.20	50	25.00	1010-5.20	■
5.30	50	25.00	1010-5.30	■
5.40	50	25.00	1010-5.40	■
5.50	50	25.00	1010-5.50	■
5.60	50	25.00	1010-5.60	■
5.70	50	25.00	1010-5.70	■
5.80	50	25.00	1010-5.80	■
5.90	50	25.00	1010-5.90	■
6.00	50	25.00	1010-6.00	■

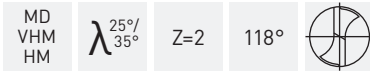

D h6	L1	L2	Art. N°	Z
0.50	30	5.00	<b>2010-0.50</b>	■
0.55	30	5.00	<b>2010-0.55</b>	■
0.60	30	5.00	<b>2010-0.60</b>	■
0.65	30	6.00	<b>2010-0.65</b>	■
0.70	30	6.00	<b>2010-0.70</b>	■
0.75	30	8.00	<b>2010-0.75</b>	■
0.80	30	8.00	<b>2010-0.80</b>	■
0.85	30	9.00	<b>2010-0.85</b>	■
0.90	30	9.00	<b>2010-0.90</b>	■
0.95	30	10.00	<b>2010-0.95</b>	■
1.00	30	10.00	<b>2010-1.00</b>	■
1.05	30	10.00	<b>2010-1.05</b>	■
1.10	30	10.00	<b>2010-1.10</b>	■
1.15	30	12.00	<b>2010-1.15</b>	■
1.20	30	12.00	<b>2010-1.20</b>	■
1.25	30	12.00	<b>2010-1.25</b>	■
1.30	30	12.00	<b>2010-1.30</b>	■
1.35	30	12.00	<b>2010-1.35</b>	■
1.40	30	12.00	<b>2010-1.40</b>	■
1.45	30	12.00	<b>2010-1.45</b>	■
1.50	30	12.00	<b>2010-1.50</b>	■
1.55	40	16.00	<b>2010-1.55</b>	■
1.60	40	16.00	<b>2010-1.60</b>	■
1.65	40	16.00	<b>2010-1.65</b>	■
1.70	40	16.00	<b>2010-1.70</b>	■
1.75	40	16.00	<b>2010-1.75</b>	■
1.80	40	16.00	<b>2010-1.80</b>	■
1.85	40	16.00	<b>2010-1.85</b>	■
1.90	40	16.00	<b>2010-1.90</b>	■
1.95	40	16.00	<b>2010-1.95</b>	■
2.00	40	16.00	<b>2010-2.00</b>	■
2.05	40	18.00	<b>2010-2.05</b>	■
2.10	40	18.00	<b>2010-2.10</b>	■
2.15	40	18.00	<b>2010-2.15</b>	■
2.20	40	18.00	<b>2010-2.20</b>	■
2.25	40	18.00	<b>2010-2.25</b>	■
2.30	40	18.00	<b>2010-2.30</b>	■
2.35	40	18.00	<b>2010-2.35</b>	■
2.40	40	18.00	<b>2010-2.40</b>	■
2.45	40	18.00	<b>2010-2.45</b>	■
2.50	40	18.00	<b>2010-2.50</b>	■

D h6	L1	L2	Art. N°	Z
2.55	45	18.00	<b>2010-2.55</b>	■
2.60	45	18.00	<b>2010-2.60</b>	■
2.65	45	18.00	<b>2010-2.65</b>	■
2.70	45	18.00	<b>2010-2.70</b>	■
2.75	45	18.00	<b>2010-2.75</b>	■
2.80	45	18.00	<b>2010-2.80</b>	■
2.85	45	18.00	<b>2010-2.85</b>	■
2.90	45	18.00	<b>2010-2.90</b>	■
2.95	45	18.00	<b>2010-2.95</b>	■
3.00	45	18.00	<b>2010-3.00</b>	■
3.10	50	20.00	<b>2010-3.10</b>	■
3.20	50	20.00	<b>2010-3.20</b>	■
3.30	50	20.00	<b>2010-3.30</b>	■
3.40	50	20.00	<b>2010-3.40</b>	■
3.50	50	20.00	<b>2010-3.50</b>	■
3.60	50	20.00	<b>2010-3.60</b>	■
3.70	50	20.00	<b>2010-3.70</b>	■
3.80	50	20.00	<b>2010-3.80</b>	■
3.90	50	20.00	<b>2010-3.90</b>	■
4.00	50	20.00	<b>2010-4.00</b>	■
4.10	50	25.00	<b>2010-4.10</b>	■
4.20	50	25.00	<b>2010-4.20</b>	■
4.30	50	25.00	<b>2010-4.30</b>	■
4.40	50	25.00	<b>2010-4.40</b>	■
4.50	50	25.00	<b>2010-4.50</b>	■
4.60	50	25.00	<b>2010-4.60</b>	■
4.70	50	25.00	<b>2010-4.70</b>	■
4.80	50	25.00	<b>2010-4.80</b>	■
4.90	50	25.00	<b>2010-4.90</b>	■
5.00	50	25.00	<b>2010-5.00</b>	■
5.10	50	25.00	<b>2010-5.10</b>	■
5.20	50	25.00	<b>2010-5.20</b>	■
5.30	50	25.00	<b>2010-5.30</b>	■
5.40	50	25.00	<b>2010-5.40</b>	■
5.50	50	25.00	<b>2010-5.50</b>	■
5.60	50	25.00	<b>2010-5.60</b>	■
5.70	50	25.00	<b>2010-5.70</b>	■
5.80	50	25.00	<b>2010-5.80</b>	■
5.90	50	25.00	<b>2010-5.90</b>	■
6.00	50	25.00	<b>2010-6.00</b>	■



Micro-forets

Mikrobohrer

Micro drills

2011 / 2012

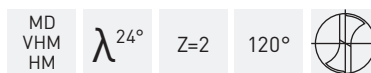
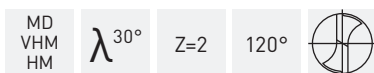
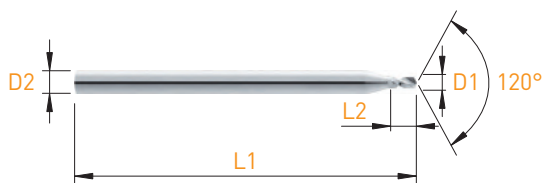

D1 h6	L2	D2 h6	L1	Art. N°	Z
0.80	2.50	2.00	30	2011-0.80	■
0.90	2.50	2.00	30	2011-0.90	■
1.00	2.50	2.00	30	2011-1.00	■
1.10	2.50	2.00	30	2011-1.10	■
1.20	2.50	2.00	30	2011-1.20	■
1.30	2.50	2.00	30	2011-1.30	■
1.40	2.50	2.00	30	2011-1.40	■
1.50	2.50	2.00	30	2011-1.50	■
2.00	2.50	2.00	30	2011-2.00	■

D1 h6	L2	D2 h6	L1	Art. N°	Z
0.50	1.70	1.50	30	2012-0.50	■
0.55	1.90	1.50	30	2012-0.55	■
0.60	1.90	1.50	30	2012-0.60	■
0.65	1.90	1.50	30	2012-0.65	■
0.70	2.40	1.50	30	2012-0.70	■
0.75	2.40	1.50	30	2012-0.75	■
0.80	2.60	1.50	30	2012-0.80	■
0.85	2.60	1.50	30	2012-0.85	■
0.90	3.00	1.50	30	2012-0.90	■
0.95	3.00	1.50	30	2012-0.95	■
1.00	3.40	1.50	30	2012-1.00	■
1.10	3.80	1.50	30	2012-1.10	■
1.20	4.20	1.50	30	2012-1.20	■
1.30	4.20	1.50	30	2012-1.30	■
1.40	4.70	1.50	30	2012-1.40	■
1.50	4.70	2.00	38	2012-1.50	■
1.60	5.40	2.00	38	2012-1.60	■
1.70	5.40	2.00	38	2012-1.70	■
1.80	6.50	2.00	38	2012-1.80	■
1.90	6.50	2.00	38	2012-1.90	■
2.00	6.50	3.00	38	2012-2.00	■
2.10	6.50	3.00	38	2012-2.10	■
2.20	6.50	3.00	38	2012-2.20	■
2.30	6.50	3.00	38	2012-2.30	■
2.40	6.50	3.00	38	2012-2.40	■

# MICRO-LINE

Micro-forets

Mikrobohrer

Micro drills

2013 / 2014

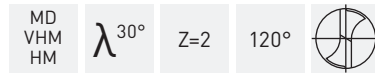
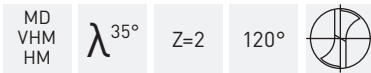
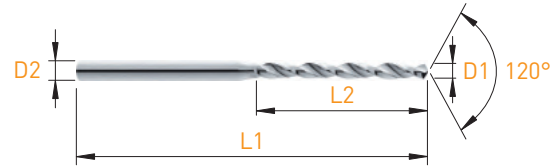
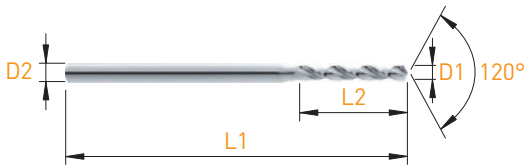

D1 h6	L2	D2 h6	L1	Art. N°	Z
0.40	3.60	1.00	25	2013-0.40	■
0.45	3.60	1.00	25	2013-0.45	■
0.50	4.00	1.00	25	2013-0.50	■
0.55	4.50	1.00	25	2013-0.55	■
0.60	4.50	1.50	30	2013-0.60	■
0.65	5.00	1.50	30	2013-0.65	■
0.70	5.60	1.50	30	2013-0.70	■
0.75	5.60	1.50	30	2013-0.75	■
0.80	6.30	1.50	30	2013-0.80	■
0.85	6.30	1.50	30	2013-0.85	■
0.90	7.10	1.50	30	2013-0.90	■
0.95	7.10	1.50	30	2013-0.95	■
1.00	8.00	1.50	30	2013-1.00	■
1.05	8.00	1.50	30	2013-1.05	■
1.10	9.00	1.50	30	2013-1.10	■
1.15	9.00	1.50	30	2013-1.15	■
1.20	10.00	1.50	30	2013-1.20	■
1.25	10.00	1.50	30	2013-1.25	■
1.30	10.00	1.50	30	2013-1.30	■
1.35	11.20	1.50	30	2013-1.35	■
1.40	11.20	1.50	30	2013-1.40	■
1.45	11.20	1.50	30	2013-1.45	■
1.50	12.00	2.00	38	2013-1.50	■
1.60	12.00	2.00	38	2013-1.60	■
1.70	12.00	2.00	38	2013-1.70	■
1.80	12.00	2.00	38	2013-1.80	■
1.90	12.00	2.00	38	2013-1.90	■

D1 h6	L2	D2 h6	L1	Art. N°	Z
0.50	6.00	1.50	30	2014-0.50	■
0.55	6.50	1.50	30	2014-0.55	■
0.60	6.50	1.50	30	2014-0.60	■
0.65	7.50	1.50	30	2014-0.65	■
0.70	8.50	1.50	30	2014-0.70	■
0.75	8.50	1.50	30	2014-0.75	■
0.80	9.50	1.50	30	2014-0.80	■
0.85	9.50	1.50	30	2014-0.85	■
0.90	10.50	1.50	30	2014-0.90	■
0.95	10.50	1.50	30	2014-0.95	■
1.00	12.00	1.50	38	2014-1.00	■
1.05	12.00	1.50	38	2014-1.05	■
1.10	13.50	1.50	38	2014-1.10	■
1.15	13.50	1.50	38	2014-1.15	■
1.20	15.00	1.50	38	2014-1.20	■
1.25	15.00	1.50	38	2014-1.25	■
1.30	17.00	1.50	38	2014-1.30	■
1.35	17.00	1.50	38	2014-1.35	■
1.40	17.00	1.50	38	2014-1.40	■
1.45	17.00	1.50	38	2014-1.45	■
1.50	18.00	2.00	38	2014-1.50	■
1.55	18.00	2.00	38	2014-1.55	■
1.60	18.00	2.00	38	2014-1.60	■
1.65	18.00	2.00	38	2014-1.65	■
1.70	18.00	2.00	38	2014-1.70	■
1.75	18.00	2.00	38	2014-1.75	■
1.80	18.00	2.00	38	2014-1.80	■
1.85	18.00	2.00	38	2014-1.85	■
1.90	18.00	2.00	38	2014-1.90	■
1.95	18.00	2.00	38	2014-1.95	■

Micro-forets de préperçage

Mikro Pilotbohrer

Micro pilot drill

Ø 0.10 - Ø 0.99 mm

2020

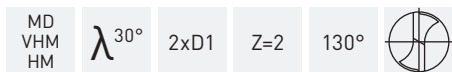
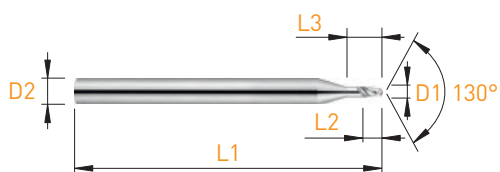

D1 +0.005 / 0	L2	L3	L1	D2 h6	Art. N°	z
0.10	0.35	0.55	38	3.00	2020-0.10	■
0.11	0.35	0.55	38	3.00	2020-0.11	■
0.12	0.35	0.55	38	3.00	2020-0.12	■
0.13	0.40	0.60	38	3.00	2020-0.13	■
0.14	0.40	0.60	38	3.00	2020-0.14	■
0.15	0.40	0.60	38	3.00	2020-0.15	■
0.16	0.40	0.60	38	3.00	2020-0.16	■
0.17	0.50	0.70	38	3.00	2020-0.17	■
0.18	0.50	0.70	38	3.00	2020-0.18	■
0.19	0.50	0.70	38	3.00	2020-0.19	■
0.20	0.55	0.75	38	3.00	2020-0.20	■
0.21	0.55	0.75	38	3.00	2020-0.21	■
0.22	0.60	0.80	38	3.00	2020-0.22	■
0.23	0.60	0.80	38	3.00	2020-0.23	■
0.24	0.60	0.80	38	3.00	2020-0.24	■
0.25	0.70	0.90	38	3.00	2020-0.25	■
0.26	0.70	0.90	38	3.00	2020-0.26	■
0.27	0.70	0.90	38	3.00	2020-0.27	■
0.28	0.80	1.00	38	3.00	2020-0.28	■
0.29	0.80	1.00	38	3.00	2020-0.29	■
0.30	0.90	1.20	38	3.00	2020-0.30	■
0.31	0.90	1.20	38	3.00	2020-0.31	■
0.32	0.90	1.20	38	3.00	2020-0.32	■
0.33	0.90	1.20	38	3.00	2020-0.33	■
0.34	0.90	1.35	38	3.00	2020-0.34	■
0.35	0.90	1.35	38	3.00	2020-0.35	■
0.36	0.95	1.35	38	3.00	2020-0.36	■
0.37	0.95	1.35	38	3.00	2020-0.37	■
0.38	0.95	1.50	38	3.00	2020-0.38	■
0.39	0.95	1.50	38	3.00	2020-0.39	■
0.40	0.80	1.60	38	3.00	2020-0.40	■
0.41	0.82	1.60	38	3.00	2020-0.41	■
0.42	0.84	1.60	38	3.00	2020-0.42	■
0.43	0.86	1.60	38	3.00	2020-0.43	■
0.44	0.88	1.60	38	3.00	2020-0.44	■
0.45	0.90	1.60	38	3.00	2020-0.45	■
0.46	0.92	1.70	38	3.00	2020-0.46	■
0.47	0.94	1.70	38	3.00	2020-0.47	■
0.48	0.96	1.70	38	3.00	2020-0.48	■

D1 +0.005 / 0	L2	L3	L1	D2 h6	Art. N°	z
0.49	0.98	1.70	38	3.00	2020-0.49	■
0.50	1.00	1.70	38	3.00	2020-0.50	■
0.51	1.02	1.80	38	3.00	2020-0.51	■
0.52	1.04	1.80	38	3.00	2020-0.52	■
0.53	1.06	1.80	38	3.00	2020-0.53	■
0.54	1.08	1.80	38	3.00	2020-0.54	■
0.55	1.10	1.80	38	3.00	2020-0.55	■
0.56	1.12	1.90	38	3.00	2020-0.56	■
0.57	1.14	1.90	38	3.00	2020-0.57	■
0.58	1.16	1.90	38	3.00	2020-0.58	■
0.59	1.18	1.90	38	3.00	2020-0.59	■
0.60	1.20	1.90	38	3.00	2020-0.60	■
0.61	1.22	2.00	38	3.00	2020-0.61	■
0.62	1.24	2.00	38	3.00	2020-0.62	■
0.63	1.26	2.00	38	3.00	2020-0.63	■
0.64	1.28	2.00	38	3.00	2020-0.64	■
0.65	1.30	2.00	38	3.00	2020-0.65	■
0.66	1.32	2.10	38	3.00	2020-0.66	■
0.67	1.34	2.10	38	3.00	2020-0.67	■
0.68	1.36	2.10	38	3.00	2020-0.68	■
0.69	1.38	2.10	38	3.00	2020-0.69	■
0.70	1.40	2.10	38	3.00	2020-0.70	■
0.71	1.42	2.20	38	3.00	2020-0.71	■
0.72	1.44	2.20	38	3.00	2020-0.72	■
0.73	1.46	2.20	38	3.00	2020-0.73	■
0.74	1.48	2.20	38	3.00	2020-0.74	■
0.75	1.50	2.20	38	3.00	2020-0.75	■
0.76	1.52	2.30	38	3.00	2020-0.76	■
0.77	1.54	2.30	38	3.00	2020-0.77	■
0.78	1.56	2.30	38	3.00	2020-0.78	■
0.79	1.58	2.30	38	3.00	2020-0.79	■
0.80	1.60	2.30	38	3.00	2020-0.80	■
0.81	1.62	2.40	38	3.00	2020-0.81	■
0.82	1.64	2.40	38	3.00	2020-0.82	■
0.83	1.66	2.40	38	3.00	2020-0.83	■
0.84	1.68	2.40	38	3.00	2020-0.84	■
0.85	1.70	2.40	38	3.00	2020-0.85	■
0.86	1.72	2.50	38	3.00	2020-0.86	■
0.87	1.74	2.50	38	3.00	2020-0.87	■
0.88	1.76	2.50	38	3.00	2020-0.88	■
0.89	1.78	2.50	38	3.00	2020-0.89	■
0.90	1.80	2.50	38	3.00	2020-0.90	■
0.91	1.82	2.60	38	3.00	2020-0.91	■
0.92	1.84	2.60	38	3.00	2020-0.92	■
0.93	1.86	2.60	38	3.00	2020-0.93	■
0.94	1.88	2.60	38	3.00	2020-0.94	■
0.95	1.90	2.60	38	3.00	2020-0.95	■
0.96	1.92	2.70	38	3.00	2020-0.96	■
0.97	1.94	2.70	38	3.00	2020-0.97	■
0.98	1.96	2.70	38	3.00	2020-0.98	■
0.99	1.98	2.70	38	3.00	2020-0.99	■

D1 +0.005/0	L2	L3	L1	D2 h6	Art. N°	Z
1.00	2.00	2.70	38	3.00	<b>2020-1.00</b>	■
1.01	2.02	3.50	38	3.00	<b>2020-1.01</b>	■
1.02	2.04	3.50	38	3.00	<b>2020-1.02</b>	■
1.03	2.06	3.50	38	3.00	<b>2020-1.03</b>	■
1.04	2.08	3.50	38	3.00	<b>2020-1.04</b>	■
1.05	2.10	3.50	38	3.00	<b>2020-1.05</b>	■
1.06	2.12	3.60	38	3.00	<b>2020-1.06</b>	■
1.07	2.14	3.60	38	3.00	<b>2020-1.07</b>	■
1.08	2.16	3.60	38	3.00	<b>2020-1.08</b>	■
1.09	2.18	3.60	38	3.00	<b>2020-1.09</b>	■
1.10	2.20	3.60	38	3.00	<b>2020-1.10</b>	■
1.11	2.22	3.70	38	3.00	<b>2020-1.11</b>	■
1.12	2.24	3.70	38	3.00	<b>2020-1.12</b>	■
1.13	2.26	3.70	38	3.00	<b>2020-1.13</b>	■
1.14	2.28	3.70	38	3.00	<b>2020-1.14</b>	■
1.15	2.30	3.70	38	3.00	<b>2020-1.15</b>	■
1.16	2.32	3.80	38	3.00	<b>2020-1.16</b>	■
1.17	2.34	3.80	38	3.00	<b>2020-1.17</b>	■
1.18	2.36	3.80	38	3.00	<b>2020-1.18</b>	■
1.19	2.38	3.80	38	3.00	<b>2020-1.19</b>	■
1.20	2.40	3.80	38	3.00	<b>2020-1.20</b>	■
1.21	2.42	4.20	38	3.00	<b>2020-1.21</b>	■
1.22	2.44	4.20	38	3.00	<b>2020-1.22</b>	■
1.23	2.46	4.20	38	3.00	<b>2020-1.23</b>	■
1.24	2.48	4.20	38	3.00	<b>2020-1.24</b>	■
1.25	2.50	4.20	38	3.00	<b>2020-1.25</b>	■
1.26	2.52	4.30	38	3.00	<b>2020-1.26</b>	■
1.27	2.54	4.30	38	3.00	<b>2020-1.27</b>	■
1.28	2.56	4.30	38	3.00	<b>2020-1.28</b>	■
1.29	2.58	4.30	38	3.00	<b>2020-1.29</b>	■
1.30	2.60	4.30	38	3.00	<b>2020-1.30</b>	■
1.31	2.62	4.40	38	3.00	<b>2020-1.31</b>	■
1.32	2.64	4.40	38	3.00	<b>2020-1.32</b>	■
1.33	2.66	4.40	38	3.00	<b>2020-1.33</b>	■
1.34	2.68	4.40	38	3.00	<b>2020-1.34</b>	■
1.35	2.70	4.40	38	3.00	<b>2020-1.35</b>	■
1.36	2.72	4.50	38	3.00	<b>2020-1.36</b>	■
1.37	2.74	4.50	38	3.00	<b>2020-1.37</b>	■
1.38	2.76	4.50	38	3.00	<b>2020-1.38</b>	■
1.39	2.78	4.50	38	3.00	<b>2020-1.39</b>	■
1.40	2.80	4.50	38	3.00	<b>2020-1.40</b>	■
1.41	2.82	4.60	38	3.00	<b>2020-1.41</b>	■
1.42	2.84	4.60	38	3.00	<b>2020-1.42</b>	■
1.43	2.86	4.60	38	3.00	<b>2020-1.43</b>	■
1.44	2.88	4.60	38	3.00	<b>2020-1.44</b>	■
1.45	2.90	4.60	38	3.00	<b>2020-1.45</b>	■
1.46	2.92	4.70	38	3.00	<b>2020-1.46</b>	■
1.47	2.94	4.70	38	3.00	<b>2020-1.47</b>	■
1.48	2.96	4.70	38	3.00	<b>2020-1.48</b>	■
1.49	2.98	4.70	38	3.00	<b>2020-1.49</b>	■
1.50	3.00	4.70	38	3.00	<b>2020-1.50</b>	■

D1 +0.005/0	L2	L3	L1	D2 h6	Art. N°	Z
1.51	3.02	5.10	38	3.00	<b>2020-1.51</b>	■
1.52	3.04	5.10	38	3.00	<b>2020-1.52</b>	■
1.53	3.06	5.10	38	3.00	<b>2020-1.53</b>	■
1.54	3.08	5.10	38	3.00	<b>2020-1.54</b>	■
1.55	3.10	5.10	38	3.00	<b>2020-1.55</b>	■
1.56	3.12	5.20	38	3.00	<b>2020-1.56</b>	■
1.57	3.14	5.20	38	3.00	<b>2020-1.57</b>	■
1.58	3.16	5.20	38	3.00	<b>2020-1.58</b>	■
1.59	3.18	5.20	38	3.00	<b>2020-1.59</b>	■
1.60	3.20	5.20	38	3.00	<b>2020-1.60</b>	■
1.61	3.22	5.30	38	3.00	<b>2020-1.61</b>	■
1.62	3.24	5.30	38	3.00	<b>2020-1.62</b>	■
1.63	3.26	5.30	38	3.00	<b>2020-1.63</b>	■
1.64	3.28	5.30	38	3.00	<b>2020-1.64</b>	■
1.65	3.30	5.30	38	3.00	<b>2020-1.65</b>	■
1.66	3.32	5.40	38	3.00	<b>2020-1.66</b>	■
1.67	3.34	5.40	38	3.00	<b>2020-1.67</b>	■
1.68	3.36	5.40	38	3.00	<b>2020-1.68</b>	■
1.69	3.38	5.40	38	3.00	<b>2020-1.69</b>	■
1.70	3.40	5.40	38	3.00	<b>2020-1.70</b>	■
1.71	3.42	5.50	38	3.00	<b>2020-1.71</b>	■
1.72	3.44	5.50	38	3.00	<b>2020-1.72</b>	■
1.73	3.46	5.50	38	3.00	<b>2020-1.73</b>	■
1.74	3.48	5.50	38	3.00	<b>2020-1.74</b>	■
1.75	3.50	5.50	38	3.00	<b>2020-1.75</b>	■
1.76	3.52	5.60	38	3.00	<b>2020-1.76</b>	■
1.77	3.54	5.60	38	3.00	<b>2020-1.77</b>	■
1.78	3.56	5.60	38	3.00	<b>2020-1.78</b>	■
1.79	3.58	5.60	38	3.00	<b>2020-1.79</b>	■
1.80	3.60	5.60	38	3.00	<b>2020-1.80</b>	■
1.81	3.62	5.70	38	3.00	<b>2020-1.81</b>	■
1.82	3.64	5.70	38	3.00	<b>2020-1.82</b>	■
1.83	3.66	5.70	38	3.00	<b>2020-1.83</b>	■
1.84	3.68	5.70	38	3.00	<b>2020-1.84</b>	■
1.85	3.70	5.70	38	3.00	<b>2020-1.85</b>	■
1.86	3.72	5.80	38	3.00	<b>2020-1.86</b>	■
1.87	3.74	5.80	38	3.00	<b>2020-1.87</b>	■
1.88	3.76	5.80	38	3.00	<b>2020-1.88</b>	■
1.89	3.78	5.80	38	3.00	<b>2020-1.89</b>	■
1.90	3.80	5.80	38	3.00	<b>2020-1.90</b>	■
1.91	3.82	5.90	38	3.00	<b>2020-1.91</b>	■
1.92	3.84	5.90	38	3.00	<b>2020-1.92</b>	■
1.93	3.86	5.90	38	3.00	<b>2020-1.93</b>	■
1.94	3.88	5.90	38	3.00	<b>2020-1.94</b>	■
1.95	3.90	5.90	38	3.00	<b>2020-1.95</b>	■
1.96	3.92	6.00	38	3.00	<b>2020-1.96</b>	■
1.97	3.94	6.00	38	3.00	<b>2020-1.97</b>	■
1.98	3.96	6.00	38	3.00	<b>2020-1.98</b>	■
1.99	3.98	6.00	38	3.00	<b>2020-1.99</b>	■
2.00	4.00	6.00	38	3.00	<b>2020-2.00</b>	■

Micro-forets

Mikrobohrer

Micro drills

Ø 0.10 - Ø 0.99 mm

2023

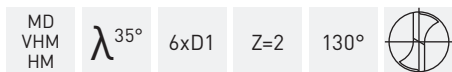
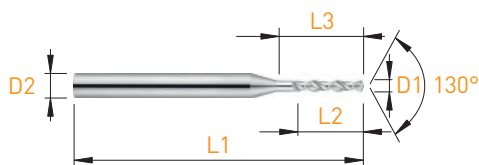

D1 0/-0.004	L2	L3	L1	D2 h6	Art. N°	z
0.10	0.50	0.70	38	3.00	2023-0.10	■
0.11	0.50	0.70	38	3.00	2023-0.11	■
0.12	0.50	0.70	38	3.00	2023-0.12	■
0.13	0.80	1.00	38	3.00	2023-0.13	■
0.14	0.80	1.00	38	3.00	2023-0.14	■
0.15	0.80	1.00	38	3.00	2023-0.15	■
0.16	1.10	1.40	38	3.00	2023-0.16	■
0.17	1.10	1.40	38	3.00	2023-0.17	■
0.18	1.10	1.40	38	3.00	2023-0.18	■
0.19	1.10	1.40	38	3.00	2023-0.19	■
0.20	1.50	1.80	38	3.00	2023-0.20	■
0.21	1.50	1.80	38	3.00	2023-0.21	■
0.22	1.50	1.80	38	3.00	2023-0.22	■
0.23	1.50	1.80	38	3.00	2023-0.23	■
0.24	1.50	1.80	38	3.00	2023-0.24	■
0.25	1.90	2.20	38	3.00	2023-0.25	■
0.26	1.90	2.20	38	3.00	2023-0.26	■
0.27	1.90	2.20	38	3.00	2023-0.27	■
0.28	1.90	2.20	38	3.00	2023-0.28	■
0.29	1.90	2.20	38	3.00	2023-0.29	■
0.30	1.80	2.40	38	3.00	2023-0.30	■
0.31	1.80	2.40	38	3.00	2023-0.31	■
0.32	1.80	2.40	38	3.00	2023-0.32	■
0.33	1.80	2.40	38	3.00	2023-0.33	■
0.34	1.80	2.40	38	3.00	2023-0.34	■
0.35	2.20	2.80	38	3.00	2023-0.35	■
0.36	2.20	2.80	38	3.00	2023-0.36	■
0.37	2.20	2.80	38	3.00	2023-0.37	■
0.38	2.20	2.80	38	3.00	2023-0.38	■
0.39	2.70	3.60	38	3.00	2023-0.39	■
0.40	2.70	3.60	38	3.00	2023-0.40	■
0.41	2.70	3.60	38	3.00	2023-0.41	■
0.42	2.70	3.60	38	3.00	2023-0.42	■
0.43	2.70	3.60	38	3.00	2023-0.43	■
0.44	2.70	3.60	38	3.00	2023-0.44	■
0.45	2.70	3.60	38	3.00	2023-0.45	■
0.46	2.70	3.60	38	3.00	2023-0.46	■
0.47	2.70	3.60	38	3.00	2023-0.47	■
0.48	2.70	3.60	38	3.00	2023-0.48	■

D1 0/-0.004	L2	L3	L1	D2 h6	Art. N°	z
0.49	3.20	4.00	38	3.00	2023-0.49	■
0.50	3.20	4.00	38	3.00	2023-0.50	■
0.51	3.20	4.00	38	3.00	2023-0.51	■
0.52	3.20	4.00	38	3.00	2023-0.52	■
0.53	3.20	4.00	38	3.00	2023-0.53	■
0.54	3.60	4.50	38	3.00	2023-0.54	■
0.55	3.60	4.50	38	3.00	2023-0.55	■
0.56	3.60	4.50	38	3.00	2023-0.56	■
0.57	3.60	4.50	38	3.00	2023-0.57	■
0.58	3.60	4.50	38	3.00	2023-0.58	■
0.59	3.60	4.50	38	3.00	2023-0.59	■
0.60	3.60	4.50	38	3.00	2023-0.60	■
0.61	3.90	5.00	38	3.00	2023-0.61	■
0.62	3.90	5.00	38	3.00	2023-0.62	■
0.63	3.90	5.00	38	3.00	2023-0.63	■
0.64	3.90	5.00	38	3.00	2023-0.64	■
0.65	3.90	5.00	38	3.00	2023-0.65	■
0.66	3.90	5.00	38	3.00	2023-0.66	■
0.67	3.90	5.00	38	3.00	2023-0.67	■
0.68	4.50	5.60	38	3.00	2023-0.68	■
0.69	4.50	5.60	38	3.00	2023-0.69	■
0.70	4.50	5.60	38	3.00	2023-0.70	■
0.71	4.50	5.60	38	3.00	2023-0.71	■
0.72	4.50	5.60	38	3.00	2023-0.72	■
0.73	4.50	5.60	38	3.00	2023-0.73	■
0.74	4.50	5.60	38	3.00	2023-0.74	■
0.75	4.50	5.60	38	3.00	2023-0.75	■
0.76	5.00	6.30	38	3.00	2023-0.76	■
0.77	5.00	6.30	38	3.00	2023-0.77	■
0.78	5.00	6.30	38	3.00	2023-0.78	■
0.79	5.00	6.30	38	3.00	2023-0.79	■
0.80	5.00	6.30	38	3.00	2023-0.80	■
0.81	5.00	6.30	38	3.00	2023-0.81	■
0.82	5.00	6.30	38	3.00	2023-0.82	■
0.83	5.00	6.30	38	3.00	2023-0.83	■
0.84	5.00	6.30	38	3.00	2023-0.84	■
0.85	5.00	6.30	38	3.00	2023-0.85	■
0.86	5.70	7.10	38	3.00	2023-0.86	■
0.87	5.70	7.10	38	3.00	2023-0.87	■
0.88	5.70	7.10	38	3.00	2023-0.88	■
0.89	5.70	7.10	38	3.00	2023-0.89	■
0.90	5.70	7.10	38	3.00	2023-0.90	■
0.91	5.70	7.10	38	3.00	2023-0.91	■
0.92	5.70	7.10	38	3.00	2023-0.92	■
0.93	5.70	7.10	38	3.00	2023-0.93	■
0.94	5.70	7.10	38	3.00	2023-0.94	■
0.95	5.70	7.10	38	3.00	2023-0.95	■
0.96	6.50	8.00	38	3.00	2023-0.96	■
0.97	6.50	8.00	38	3.00	2023-0.97	■
0.98	6.50	8.00	38	3.00	2023-0.98	■
0.99	6.50	8.00	38	3.00	2023-0.99	■

D1 0/-0.004	L2	L3	L1	D2 h <sub>6</sub>	Art. N°	Z
1.00	6.50	8.00	38	3.00	<b>2023-1.00</b>	■
1.01	6.50	8.00	38	3.00	<b>2023-1.01</b>	■
1.02	6.50	8.00	38	3.00	<b>2023-1.02</b>	■
1.03	6.50	8.00	38	3.00	<b>2023-1.03</b>	■
1.04	6.50	8.00	38	3.00	<b>2023-1.04</b>	■
1.05	6.50	8.00	38	3.00	<b>2023-1.05</b>	■
1.06	7.30	9.00	38	3.00	<b>2023-1.06</b>	■
1.07	7.30	9.00	38	3.00	<b>2023-1.07</b>	■
1.08	7.30	9.00	38	3.00	<b>2023-1.08</b>	■
1.09	7.30	9.00	38	3.00	<b>2023-1.09</b>	■
1.10	7.30	9.00	38	3.00	<b>2023-1.10</b>	■
1.11	7.30	9.00	38	3.00	<b>2023-1.11</b>	■
1.12	7.30	9.00	38	3.00	<b>2023-1.12</b>	■
1.13	7.30	9.00	38	3.00	<b>2023-1.13</b>	■
1.14	7.30	9.00	38	3.00	<b>2023-1.14</b>	■
1.15	7.30	9.00	38	3.00	<b>2023-1.15</b>	■
1.16	8.20	10.00	38	3.00	<b>2023-1.16</b>	■
1.17	8.20	10.00	38	3.00	<b>2023-1.17</b>	■
1.18	8.20	10.00	38	3.00	<b>2023-1.18</b>	■
1.19	8.20	10.00	38	3.00	<b>2023-1.19</b>	■
1.20	8.20	10.00	38	3.00	<b>2023-1.20</b>	■
1.21	8.20	10.00	38	3.00	<b>2023-1.21</b>	■
1.22	8.20	10.00	38	3.00	<b>2023-1.22</b>	■
1.23	8.20	10.00	38	3.00	<b>2023-1.23</b>	■
1.24	8.20	10.00	38	3.00	<b>2023-1.24</b>	■
1.25	8.20	10.00	38	3.00	<b>2023-1.25</b>	■
1.26	8.20	10.00	38	3.00	<b>2023-1.26</b>	■
1.27	8.20	10.00	38	3.00	<b>2023-1.27</b>	■
1.28	8.20	10.00	38	3.00	<b>2023-1.28</b>	■
1.29	8.20	10.00	38	3.00	<b>2023-1.29</b>	■
1.30	8.20	10.00	38	3.00	<b>2023-1.30</b>	■
1.31	9.20	11.20	38	3.00	<b>2023-1.31</b>	■
1.32	9.20	11.20	38	3.00	<b>2023-1.32</b>	■
1.33	9.20	11.20	38	3.00	<b>2023-1.33</b>	■
1.34	9.20	11.20	38	3.00	<b>2023-1.34</b>	■
1.35	9.20	11.20	38	3.00	<b>2023-1.35</b>	■
1.36	9.20	11.20	38	3.00	<b>2023-1.36</b>	■
1.37	9.20	11.20	38	3.00	<b>2023-1.37</b>	■
1.38	9.20	11.20	38	3.00	<b>2023-1.38</b>	■
1.39	9.20	11.20	38	3.00	<b>2023-1.39</b>	■
1.40	9.20	11.20	38	3.00	<b>2023-1.40</b>	■
1.41	9.20	11.20	38	3.00	<b>2023-1.41</b>	■
1.42	9.20	11.20	38	3.00	<b>2023-1.42</b>	■
1.43	9.20	11.20	38	3.00	<b>2023-1.43</b>	■
1.44	9.20	11.20	38	3.00	<b>2023-1.44</b>	■
1.45	9.20	11.20	38	3.00	<b>2023-1.45</b>	■
1.46	9.20	11.20	38	3.00	<b>2023-1.46</b>	■
1.47	9.20	11.20	38	3.00	<b>2023-1.47</b>	■
1.48	9.20	11.20	38	3.00	<b>2023-1.48</b>	■
1.49	9.20	11.20	38	3.00	<b>2023-1.49</b>	■
1.50	9.20	11.20	38	3.00	<b>2023-1.50</b>	■

D1 0/-0.004	L2	L3	L1	D2 h <sub>6</sub>	Art. N°	Z
1.51	11.20	13.40	38	3.00	<b>2023-1.51</b>	■
1.52	11.20	13.40	38	3.00	<b>2023-1.52</b>	■
1.53	11.20	13.40	38	3.00	<b>2023-1.53</b>	■
1.54	11.20	13.40	38	3.00	<b>2023-1.54</b>	■
1.55	11.20	13.40	38	3.00	<b>2023-1.55</b>	■
1.56	11.20	13.40	38	3.00	<b>2023-1.56</b>	■
1.57	11.20	13.40	38	3.00	<b>2023-1.57</b>	■
1.58	11.20	13.40	38	3.00	<b>2023-1.58</b>	■
1.59	11.20	13.40	38	3.00	<b>2023-1.59</b>	■
1.60	11.20	13.40	38	3.00	<b>2023-1.60</b>	■
1.61	11.20	13.40	38	3.00	<b>2023-1.61</b>	■
1.62	11.20	13.40	38	3.00	<b>2023-1.62</b>	■
1.63	11.20	13.40	38	3.00	<b>2023-1.63</b>	■
1.64	11.20	13.40	38	3.00	<b>2023-1.64</b>	■
1.65	11.20	13.40	38	3.00	<b>2023-1.65</b>	■
1.66	11.20	13.40	38	3.00	<b>2023-1.66</b>	■
1.67	11.20	13.40	38	3.00	<b>2023-1.67</b>	■
1.68	11.20	13.40	38	3.00	<b>2023-1.68</b>	■
1.69	11.20	13.40	38	3.00	<b>2023-1.69</b>	■
1.70	11.20	13.40	38	3.00	<b>2023-1.70</b>	■
1.71	11.20	13.40	38	3.00	<b>2023-1.71</b>	■
1.72	11.20	13.40	38	3.00	<b>2023-1.72</b>	■
1.73	11.20	13.40	38	3.00	<b>2023-1.73</b>	■
1.74	11.20	13.40	38	3.00	<b>2023-1.74</b>	■
1.75	11.20	13.40	38	3.00	<b>2023-1.75</b>	■
1.76	11.20	13.40	38	3.00	<b>2023-1.76</b>	■
1.77	11.20	13.40	38	3.00	<b>2023-1.77</b>	■
1.78	11.20	13.40	38	3.00	<b>2023-1.78</b>	■
1.79	11.20	13.40	38	3.00	<b>2023-1.79</b>	■
1.80	11.20	13.40	38	3.00	<b>2023-1.80</b>	■
1.81	11.20	13.40	38	3.00	<b>2023-1.81</b>	■
1.82	11.20	13.40	38	3.00	<b>2023-1.82</b>	■
1.83	11.20	13.40	38	3.00	<b>2023-1.83</b>	■
1.84	11.20	13.40	38	3.00	<b>2023-1.84</b>	■
1.85	11.20	13.40	38	3.00	<b>2023-1.85</b>	■
1.86	11.20	13.40	38	3.00	<b>2023-1.86</b>	■
1.87	11.20	13.40	38	3.00	<b>2023-1.87</b>	■
1.88	11.20	13.40	38	3.00	<b>2023-1.88</b>	■
1.89	11.20	13.40	38	3.00	<b>2023-1.89</b>	■
1.90	11.20	13.40	38	3.00	<b>2023-1.90</b>	■
1.91	11.20	13.40	38	3.00	<b>2023-1.91</b>	■
1.92	11.20	13.40	38	3.00	<b>2023-1.92</b>	■
1.93	11.20	13.40	38	3.00	<b>2023-1.93</b>	■
1.94	11.20	13.40	38	3.00	<b>2023-1.94</b>	■
1.95	11.20	13.40	38	3.00	<b>2023-1.95</b>	■
1.96	11.20	13.40	38	3.00	<b>2023-1.96</b>	■
1.97	11.20	13.40	38	3.00	<b>2023-1.97</b>	■
1.98	11.20	13.40	38	3.00	<b>2023-1.98</b>	■
1.99	11.20	13.40	38	3.00	<b>2023-1.99</b>	■
2.00	11.20	13.40	38	3.00	<b>2023-2.00</b>	■

Micro-forets

Mikrobohrer

Micro drills

Ø 2.01 - Ø 3.00 mm

2023

D1 0/-0.004	L2	L3	L1	D2 h6	Art. N°	Z
2.01	12.50	14.00	38	3.00	2023-2.01	■
2.02	12.50	14.00	38	3.00	2023-2.02	■
2.03	12.50	14.00	38	3.00	2023-2.03	■
2.04	12.50	14.00	38	3.00	2023-2.04	■
2.05	12.50	14.00	38	3.00	2023-2.05	■
2.06	12.50	14.00	38	3.00	2023-2.06	■
2.07	12.50	14.00	38	3.00	2023-2.07	■
2.08	12.50	14.00	38	3.00	2023-2.08	■
2.09	12.50	14.00	38	3.00	2023-2.09	■
2.10	12.50	14.00	38	3.00	2023-2.10	■
2.11	12.50	14.00	38	3.00	2023-2.11	■
2.12	12.50	14.00	38	3.00	2023-2.12	■
2.13	12.50	14.00	38	3.00	2023-2.13	■
2.14	12.50	14.00	38	3.00	2023-2.14	■
2.15	12.50	14.00	38	3.00	2023-2.15	■
2.16	12.50	14.00	38	3.00	2023-2.16	■
2.17	12.50	14.00	38	3.00	2023-2.17	■
2.18	12.50	14.00	38	3.00	2023-2.18	■
2.19	12.50	14.00	38	3.00	2023-2.19	■
2.20	12.50	14.00	38	3.00	2023-2.20	■
2.21	12.50	14.00	38	3.00	2023-2.21	■
2.22	12.50	14.00	38	3.00	2023-2.22	■
2.23	12.50	14.00	38	3.00	2023-2.23	■
2.24	12.50	14.00	38	3.00	2023-2.24	■
2.25	12.50	14.00	38	3.00	2023-2.25	■
2.26	12.50	14.00	38	3.00	2023-2.26	■
2.27	12.50	14.00	38	3.00	2023-2.27	■
2.28	12.50	14.00	38	3.00	2023-2.28	■
2.29	12.50	14.00	38	3.00	2023-2.29	■
2.30	12.50	14.00	38	3.00	2023-2.30	■
2.31	12.50	14.00	38	3.00	2023-2.31	■
2.32	12.50	14.00	38	3.00	2023-2.32	■
2.33	12.50	14.00	38	3.00	2023-2.33	■
2.34	12.50	14.00	38	3.00	2023-2.34	■
2.35	12.50	14.00	38	3.00	2023-2.35	■
2.36	12.50	14.00	38	3.00	2023-2.36	■
2.37	12.50	14.00	38	3.00	2023-2.37	■
2.38	12.50	14.00	38	3.00	2023-2.38	■
2.39	12.50	14.00	38	3.00	2023-2.39	■
2.40	12.50	14.00	38	3.00	2023-2.40	■
2.41	12.50	14.00	38	3.00	2023-2.41	■
2.42	12.50	14.00	38	3.00	2023-2.42	■
2.43	12.50	14.00	38	3.00	2023-2.43	■
2.44	12.50	14.00	38	3.00	2023-2.44	■
2.45	12.50	14.00	38	3.00	2023-2.45	■
2.46	12.50	14.00	38	3.00	2023-2.46	■
2.47	12.50	14.00	38	3.00	2023-2.47	■
2.48	12.50	14.00	38	3.00	2023-2.48	■
2.49	12.50	14.00	38	3.00	2023-2.49	■
2.50	14.00	17.00	38	3.00	2023-2.50	■

D1 0/-0.004	L2	L3	L1	D2 h6	Art. N°	Z
2.51	14.00	17.00	38	3.00	2023-2.51	■
2.52	14.00	17.00	38	3.00	2023-2.52	■
2.53	14.00	17.00	38	3.00	2023-2.53	■
2.54	14.00	17.00	38	3.00	2023-2.54	■
2.55	14.00	17.00	38	3.00	2023-2.55	■
2.56	14.00	17.00	38	3.00	2023-2.56	■
2.57	14.00	17.00	38	3.00	2023-2.57	■
2.58	14.00	17.00	38	3.00	2023-2.58	■
2.59	14.00	17.00	38	3.00	2023-2.59	■
2.60	14.00	17.00	38	3.00	2023-2.60	■
2.61	14.00	17.00	38	3.00	2023-2.61	■
2.62	14.00	17.00	38	3.00	2023-2.62	■
2.63	14.00	17.00	38	3.00	2023-2.63	■
2.64	14.00	17.00	38	3.00	2023-2.64	■
2.65	14.00	17.00	38	3.00	2023-2.65	■
2.66	14.00	17.00	38	3.00	2023-2.66	■
2.67	14.00	17.00	38	3.00	2023-2.67	■
2.68	14.00	17.00	38	3.00	2023-2.68	■
2.69	14.00	17.00	38	3.00	2023-2.69	■
2.70	14.00	17.00	38	3.00	2023-2.70	■
2.71	14.00	17.00	38	3.00	2023-2.71	■
2.72	14.00	17.00	38	3.00	2023-2.72	■
2.73	14.00	17.00	38	3.00	2023-2.73	■
2.74	14.00	17.00	38	3.00	2023-2.74	■
2.75	14.00	17.00	38	3.00	2023-2.75	■
2.76	14.00	17.00	38	3.00	2023-2.76	■
2.77	14.00	17.00	38	3.00	2023-2.77	■
2.78	14.00	17.00	38	3.00	2023-2.78	■
2.79	14.00	17.00	38	3.00	2023-2.79	■
2.80	14.00	17.00	38	3.00	2023-2.80	■
2.81	14.00	17.00	38	3.00	2023-2.81	■
2.82	14.00	17.00	38	3.00	2023-2.82	■
2.83	14.00	17.00	38	3.00	2023-2.83	■
2.84	14.00	17.00	38	3.00	2023-2.84	■
2.85	14.00	17.00	38	3.00	2023-2.85	■
2.86	14.00	17.00	38	3.00	2023-2.86	■
2.87	14.00	17.00	38	3.00	2023-2.87	■
2.88	14.00	17.00	38	3.00	2023-2.88	■
2.89	14.00	17.00	38	3.00	2023-2.89	■
2.90	14.00	17.00	38	3.00	2023-2.90	■
2.91	14.00	17.00	38	3.00	2023-2.91	■
2.92	14.00	17.00	38	3.00	2023-2.92	■
2.93	14.00	17.00	38	3.00	2023-2.93	■
2.94	14.00	17.00	38	3.00	2023-2.94	■
2.95	14.00	17.00	38	3.00	2023-2.95	■
2.96	14.00	17.00	38	3.00	2023-2.96	■
2.97	14.00	17.00	38	3.00	2023-2.97	■
2.98	14.00	17.00	38	3.00	2023-2.98	■
2.99	14.00	17.00	38	3.00	2023-2.99	■
3.00	14.00	17.00	38	3.00	2023-3.00	■

# MICRO-LINE

Micro-forets

Mikrobohrer

Micro drills

Ø 0.20 - Ø 1.09 mm

2026

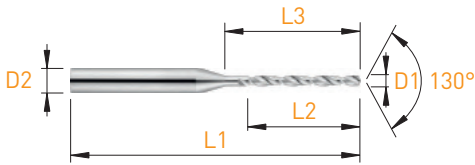

MD VHM HM	$\lambda^{25^\circ}$	Z=2	12xD1	130°	
-----------------	----------------------	-----	-------	------	--

D1 h6	L2	L3	L1	D2 h6	Art. N°	z
0.20	2.40	3.50	38	3.00	2026-0.20	■
0.21	2.50	3.50	38	3.00	2026-0.21	■
0.22	2.70	3.50	38	3.00	2026-0.22	■
0.23	2.80	3.50	38	3.00	2026-0.23	■
0.24	2.90	4.00	38	3.00	2026-0.24	■
0.25	3.00	4.00	38	3.00	2026-0.25	■
0.26	3.10	4.00	38	3.00	2026-0.26	■
0.27	3.30	4.00	38	3.00	2026-0.27	■
0.28	3.40	4.50	38	3.00	2026-0.28	■
0.29	3.50	4.50	38	3.00	2026-0.29	■
0.30	3.60	4.50	38	3.00	2026-0.30	■
0.31	3.70	4.50	38	3.00	2026-0.31	■
0.32	3.90	5.00	38	3.00	2026-0.32	■
0.33	4.00	5.00	38	3.00	2026-0.33	■
0.34	4.10	5.00	38	3.00	2026-0.34	■
0.35	4.20	5.00	38	3.00	2026-0.35	■
0.36	4.30	5.50	38	3.00	2026-0.36	■
0.37	4.50	5.50	38	3.00	2026-0.37	■
0.38	4.60	5.50	38	3.00	2026-0.38	■
0.39	4.70	5.50	38	3.00	2026-0.39	■
0.40	4.80	6.00	38	3.00	2026-0.40	■
0.41	4.90	6.00	38	3.00	2026-0.41	■
0.42	5.10	6.00	38	3.00	2026-0.42	■
0.43	5.20	6.00	38	3.00	2026-0.43	■
0.44	5.30	6.50	38	3.00	2026-0.44	■
0.45	5.40	6.50	38	3.00	2026-0.45	■
0.46	5.50	6.50	38	3.00	2026-0.46	■
0.47	5.70	6.50	38	3.00	2026-0.47	■
0.48	5.80	7.00	38	3.00	2026-0.48	■
0.49	5.90	7.00	38	3.00	2026-0.49	■
0.50	6.00	7.00	38	3.00	2026-0.50	■
0.51	6.10	7.00	38	3.00	2026-0.51	■
0.52	6.30	7.50	38	3.00	2026-0.52	■
0.53	6.40	7.50	38	3.00	2026-0.53	■
0.54	6.50	7.50	38	3.00	2026-0.54	■
0.55	6.60	7.50	38	3.00	2026-0.55	■
0.56	6.70	8.00	38	3.00	2026-0.56	■
0.57	6.90	8.00	38	3.00	2026-0.57	■
0.58	7.00	8.00	38	3.00	2026-0.58	■

D1 h6	L2	L3	L1	D2 h6	Art. N°	z
0.59	7.10	8.00	38	3.00	2026-0.59	■
0.60	7.20	9.00	38	3.00	2026-0.60	■
0.61	7.30	9.00	38	3.00	2026-0.61	■
0.62	7.50	9.00	38	3.00	2026-0.62	■
0.63	7.60	9.00	38	3.00	2026-0.63	■
0.64	7.70	9.50	38	3.00	2026-0.64	■
0.65	7.80	9.50	38	3.00	2026-0.65	■
0.66	7.90	9.50	38	3.00	2026-0.66	■
0.67	8.10	9.50	38	3.00	2026-0.67	■
0.68	8.20	10.00	38	3.00	2026-0.68	■
0.69	8.30	10.00	38	3.00	2026-0.69	■
0.70	8.40	10.00	38	3.00	2026-0.70	■
0.71	8.50	10.00	38	3.00	2026-0.71	■
0.72	8.70	10.50	38	3.00	2026-0.72	■
0.73	8.80	10.50	38	3.00	2026-0.73	■
0.74	8.90	10.50	38	3.00	2026-0.74	■
0.75	9.00	10.50	38	3.00	2026-0.75	■
0.76	9.10	11.00	38	3.00	2026-0.76	■
0.77	9.30	11.00	38	3.00	2026-0.77	■
0.78	9.40	11.00	38	3.00	2026-0.78	■
0.79	9.50	11.00	38	3.00	2026-0.79	■
0.80	9.60	11.50	38	3.00	2026-0.80	■
0.81	9.70	11.50	38	3.00	2026-0.81	■
0.82	9.90	11.50	38	3.00	2026-0.82	■
0.83	10.00	11.50	38	3.00	2026-0.83	■
0.84	10.10	12.00	38	3.00	2026-0.84	■
0.85	10.20	12.00	38	3.00	2026-0.85	■
0.86	10.30	12.00	38	3.00	2026-0.86	■
0.87	10.50	12.00	38	3.00	2026-0.87	■
0.88	10.60	12.50	38	3.00	2026-0.88	■
0.89	10.70	12.50	38	3.00	2026-0.89	■
0.90	10.80	12.50	38	3.00	2026-0.90	■
0.91	10.90	12.50	38	3.00	2026-0.91	■
0.92	11.10	13.00	38	3.00	2026-0.92	■
0.93	11.20	13.00	38	3.00	2026-0.93	■
0.94	11.30	13.00	38	3.00	2026-0.94	■
0.95	11.40	13.00	38	3.00	2026-0.95	■
0.96	11.50	13.50	38	3.00	2026-0.96	■
0.97	11.70	13.50	38	3.00	2026-0.97	■
0.98	11.80	13.50	38	3.00	2026-0.98	■
0.99	11.90	13.50	38	3.00	2026-0.99	■
1.00	12.00	14.50	38	3.00	2026-1.00	■
1.01	12.10	14.50	38	3.00	2026-1.01	■
1.02	12.30	14.50	38	3.00	2026-1.02	■
1.03	12.40	14.50	38	3.00	2026-1.03	■
1.04	12.50	15.00	38	3.00	2026-1.04	■
1.05	12.60	15.00	38	3.00	2026-1.05	■
1.06	12.70	15.00	38	3.00	2026-1.06	■
1.07	12.90	15.00	38	3.00	2026-1.07	■
1.08	13.00	15.50	38	3.00	2026-1.08	■
1.09	13.10	15.50	38	3.00	2026-1.09	■



Micro-forets

Mikrobohrer

Micro drills

Ø 1.10 - Ø 2.00 mm

2026

D1 h6	L2	L3	L1	D2 h6	Art. N°	Z
1.10	13.20	15.50	38	3.00	2026-1.10	■
1.11	13.30	15.50	38	3.00	2026-1.11	■
1.12	13.50	16.00	38	3.00	2026-1.12	■
1.13	13.60	16.00	38	3.00	2026-1.13	■
1.14	13.70	16.00	38	3.00	2026-1.14	■
1.15	13.80	16.00	38	3.00	2026-1.15	■
1.16	13.90	16.50	38	3.00	2026-1.16	■
1.17	14.10	16.50	38	3.00	2026-1.17	■
1.18	14.20	16.50	38	3.00	2026-1.18	■
1.19	14.30	16.50	38	3.00	2026-1.19	■
1.20	14.40	17.00	38	3.00	2026-1.20	■
1.21	14.50	17.00	38	3.00	2026-1.21	■
1.22	14.70	17.00	38	3.00	2026-1.22	■
1.23	14.80	17.00	38	3.00	2026-1.23	■
1.24	14.90	17.50	38	3.00	2026-1.24	■
1.25	15.00	17.50	38	3.00	2026-1.25	■
1.26	15.10	17.50	50	3.00	2026-1.26	■
1.27	15.30	17.50	50	3.00	2026-1.27	■
1.28	15.40	18.00	50	3.00	2026-1.28	■
1.29	15.50	18.00	50	3.00	2026-1.29	■
1.30	15.60	18.00	50	3.00	2026-1.30	■
1.31	15.70	18.00	50	3.00	2026-1.31	■
1.32	15.90	18.50	50	3.00	2026-1.32	■
1.33	16.00	18.50	50	3.00	2026-1.33	■
1.34	16.10	18.50	50	3.00	2026-1.34	■
1.35	16.20	18.50	50	3.00	2026-1.35	■
1.36	16.30	19.00	50	3.00	2026-1.36	■
1.37	16.50	19.00	50	3.00	2026-1.37	■
1.38	16.60	19.00	50	3.00	2026-1.38	■
1.39	16.70	19.00	50	3.00	2026-1.39	■
1.40	16.80	19.50	50	3.00	2026-1.40	■
1.41	16.90	19.50	50	3.00	2026-1.41	■
1.42	17.10	19.50	50	3.00	2026-1.42	■
1.43	17.20	19.50	50	3.00	2026-1.43	■
1.44	17.30	20.00	50	3.00	2026-1.44	■
1.45	17.40	20.00	50	3.00	2026-1.45	■
1.46	17.50	20.00	50	3.00	2026-1.46	■
1.47	17.70	20.00	50	3.00	2026-1.47	■
1.48	17.80	20.50	50	3.00	2026-1.48	■
1.49	17.90	20.50	50	3.00	2026-1.49	■
1.50	18.00	21.00	50	3.00	2026-1.50	■
1.51	18.10	21.00	50	3.00	2026-1.51	■
1.52	18.30	21.00	50	3.00	2026-1.52	■
1.53	18.40	21.00	50	3.00	2026-1.53	■
1.54	18.50	21.50	50	3.00	2026-1.54	■
1.55	18.60	21.50	50	3.00	2026-1.55	■
1.56	18.70	21.50	50	3.00	2026-1.56	■
1.57	18.90	21.50	50	3.00	2026-1.57	■
1.58	19.00	22.00	50	3.00	2026-1.58	■
1.59	19.10	22.00	50	3.00	2026-1.59	■
1.60	19.20	22.00	50	3.00	2026-1.60	■

D1 h6	L2	L3	L1	D2 h6	Art. N°	Z
1.61	19.30	22.00	50	3.00	2026-1.61	■
1.62	19.40	22.50	50	3.00	2026-1.62	■
1.63	19.60	22.50	50	3.00	2026-1.63	■
1.64	19.70	22.50	50	3.00	2026-1.64	■
1.65	19.80	22.50	50	3.00	2026-1.65	■
1.66	19.90	23.00	50	3.00	2026-1.66	■
1.67	20.10	23.00	50	3.00	2026-1.67	■
1.68	20.20	23.00	50	3.00	2026-1.68	■
1.69	20.30	23.00	50	3.00	2026-1.69	■
1.70	20.40	23.50	50	3.00	2026-1.70	■
1.71	20.50	23.50	50	3.00	2026-1.71	■
1.72	20.70	23.50	50	3.00	2026-1.72	■
1.73	20.80	23.50	50	3.00	2026-1.73	■
1.74	20.90	24.00	50	3.00	2026-1.74	■
1.75	21.00	24.00	50	3.00	2026-1.75	■
1.76	21.10	24.00	50	3.00	2026-1.76	■
1.77	21.30	24.00	50	3.00	2026-1.77	■
1.78	21.40	24.50	50	3.00	2026-1.78	■
1.79	21.50	24.50	50	3.00	2026-1.79	■
1.80	21.60	25.00	50	3.00	2026-1.80	■
1.81	21.70	25.00	50	3.00	2026-1.81	■
1.82	21.90	25.00	50	3.00	2026-1.82	■
1.83	22.00	25.00	50	3.00	2026-1.83	■
1.84	22.10	25.50	50	3.00	2026-1.84	■
1.85	22.20	25.50	50	3.00	2026-1.85	■
1.86	22.30	25.50	50	3.00	2026-1.86	■
1.87	22.50	25.50	50	3.00	2026-1.87	■
1.88	22.60	26.00	50	3.00	2026-1.88	■
1.89	22.70	26.00	50	3.00	2026-1.89	■
1.90	22.80	26.00	50	3.00	2026-1.90	■
1.91	22.90	26.00	50	3.00	2026-1.91	■
1.92	23.10	26.50	50	3.00	2026-1.92	■
1.93	23.20	26.50	50	3.00	2026-1.93	■
1.94	23.30	26.50	50	3.00	2026-1.94	■
1.95	23.40	26.50	50	3.00	2026-1.95	■
1.96	23.50	27.00	50	3.00	2026-1.96	■
1.97	23.70	27.00	50	3.00	2026-1.97	■
1.98	23.80	27.00	50	3.00	2026-1.98	■
1.99	23.90	27.00	50	3.00	2026-1.99	■
2.00	24.00	27.00	50	3.00	2026-2.00	■

# MICRO-LINE

Micro-forets

Mikrobohrer

Micro drills

Ø 0.20 - Ø 1.09 mm

2030

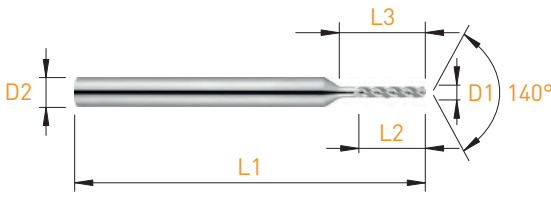

D1 h6	L2	L3	L1	D2 h6	Art. N°	Z
0.20	1.00	1.50	38	3.00	2030-0.20	■
0.21	1.05	1.50	38	3.00	2030-0.21	■
0.22	1.10	1.60	38	3.00	2030-0.22	■
0.23	1.15	1.60	38	3.00	2030-0.23	■
0.24	1.20	1.70	38	3.00	2030-0.24	■
0.25	1.25	1.70	38	3.00	2030-0.25	■
0.26	1.30	1.80	38	3.00	2030-0.26	■
0.27	1.35	1.80	38	3.00	2030-0.27	■
0.28	1.40	1.90	38	3.00	2030-0.28	■
0.29	1.45	1.90	38	3.00	2030-0.29	■
0.30	1.50	2.00	38	3.00	2030-0.30	■
0.31	1.55	2.00	38	3.00	2030-0.31	■
0.32	1.60	2.10	38	3.00	2030-0.32	■
0.33	1.65	2.10	38	3.00	2030-0.33	■
0.34	1.70	2.20	38	3.00	2030-0.34	■
0.35	1.75	2.20	38	3.00	2030-0.35	■
0.36	1.80	2.30	38	3.00	2030-0.36	■
0.37	1.85	2.30	38	3.00	2030-0.37	■
0.38	1.90	2.40	38	3.00	2030-0.38	■
0.39	1.95	2.40	38	3.00	2030-0.39	■
0.40	2.00	2.50	38	3.00	2030-0.40	■
0.41	2.05	2.50	38	3.00	2030-0.41	■
0.42	2.10	2.60	38	3.00	2030-0.42	■
0.43	2.15	2.60	38	3.00	2030-0.43	■
0.44	2.20	2.70	38	3.00	2030-0.44	■
0.45	2.25	2.70	38	3.00	2030-0.45	■
0.46	2.30	2.80	38	3.00	2030-0.46	■
0.47	2.35	2.80	38	3.00	2030-0.47	■
0.48	2.40	2.90	38	3.00	2030-0.48	■
0.49	2.45	2.90	38	3.00	2030-0.49	■
0.50	2.50	3.00	38	3.00	2030-0.50	■
0.51	2.55	3.00	38	3.00	2030-0.51	■
0.52	2.60	3.10	38	3.00	2030-0.52	■
0.53	2.65	3.10	38	3.00	2030-0.53	■
0.54	2.70	3.20	38	3.00	2030-0.54	■
0.55	2.75	3.20	38	3.00	2030-0.55	■
0.56	2.80	3.30	38	3.00	2030-0.56	■
0.57	2.85	3.30	38	3.00	2030-0.57	■
0.58	2.90	3.40	38	3.00	2030-0.58	■

D1 h6	L2	L3	L1	D2 h6	Art. N°	Z
0.59	2.95	3.40	38	3.00	2030-0.59	■
0.60	3.00	3.50	38	3.00	2030-0.60	■
0.61	3.05	3.50	38	3.00	2030-0.61	■
0.62	3.10	3.60	38	3.00	2030-0.62	■
0.63	3.15	3.60	38	3.00	2030-0.63	■
0.64	3.20	3.70	38	3.00	2030-0.64	■
0.65	3.25	3.70	38	3.00	2030-0.65	■
0.66	3.30	3.80	38	3.00	2030-0.66	■
0.67	3.35	3.80	38	3.00	2030-0.67	■
0.68	3.40	3.90	38	3.00	2030-0.68	■
0.69	3.45	3.90	38	3.00	2030-0.69	■
0.70	3.50	4.00	38	3.00	2030-0.70	■
0.71	3.55	4.00	38	3.00	2030-0.71	■
0.72	3.60	4.10	38	3.00	2030-0.72	■
0.73	3.65	4.10	38	3.00	2030-0.73	■
0.74	3.70	4.20	38	3.00	2030-0.74	■
0.75	3.75	4.20	38	3.00	2030-0.75	■
0.76	3.80	4.30	38	3.00	2030-0.76	■
0.77	3.85	4.30	38	3.00	2030-0.77	■
0.78	3.90	4.40	38	3.00	2030-0.78	■
0.79	3.95	4.40	38	3.00	2030-0.79	■
0.80	4.00	4.50	38	3.00	2030-0.80	■
0.81	4.05	4.50	38	3.00	2030-0.81	■
0.82	4.10	4.60	38	3.00	2030-0.82	■
0.83	4.15	4.60	38	3.00	2030-0.83	■
0.84	4.20	4.70	38	3.00	2030-0.84	■
0.85	4.25	4.70	38	3.00	2030-0.85	■
0.86	4.30	4.80	38	3.00	2030-0.86	■
0.87	4.35	4.80	38	3.00	2030-0.87	■
0.88	4.40	4.90	38	3.00	2030-0.88	■
0.89	4.45	4.90	38	3.00	2030-0.89	■
0.90	4.50	5.00	38	3.00	2030-0.90	■
0.91	4.55	5.00	38	3.00	2030-0.91	■
0.92	4.60	5.10	38	3.00	2030-0.92	■
0.93	4.65	5.10	38	3.00	2030-0.93	■
0.94	4.70	5.20	38	3.00	2030-0.94	■
0.95	4.75	5.20	38	3.00	2030-0.95	■
0.96	4.80	5.30	38	3.00	2030-0.96	■
0.97	4.85	5.30	38	3.00	2030-0.97	■
0.98	4.90	5.40	38	3.00	2030-0.98	■
0.99	4.95	5.40	38	3.00	2030-0.99	■
1.00	5.00	6.50	38	3.00	2030-1.00	■
1.01	5.05	6.50	38	3.00	2030-1.01	■
1.02	5.10	6.50	38	3.00	2030-1.02	■
1.03	5.15	6.50	38	3.00	2030-1.03	■
1.04	5.20	6.50	38	3.00	2030-1.04	■
1.05	5.25	6.50	38	3.00	2030-1.05	■
1.06	5.30	6.50	38	3.00	2030-1.06	■
1.07	5.35	7.50	38	3.00	2030-1.07	■
1.08	5.40	7.50	38	3.00	2030-1.08	■
1.09	5.45	7.50	38	3.00	2030-1.09	■

Micro-forets

Mikrobohrer

Micro drills

Ø 1.10 - Ø 2.11 mm

2030

D1 h6	L2	L3	L1	D2 h6	Art. N°	z
1.10	5.50	7.50	38	3.00	2030-1.10	■
1.11	5.55	7.50	38	3.00	2030-1.11	■
1.12	5.60	7.50	38	3.00	2030-1.12	■
1.13	5.65	7.50	38	3.00	2030-1.13	■
1.14	5.70	7.50	38	3.00	2030-1.14	■
1.15	5.75	7.50	38	3.00	2030-1.15	■
1.16	5.80	7.50	38	3.00	2030-1.16	■
1.17	5.85	7.50	38	3.00	2030-1.17	■
1.18	5.90	8.50	38	3.00	2030-1.18	■
1.19	5.95	8.50	38	3.00	2030-1.19	■
1.20	6.00	8.50	38	3.00	2030-1.20	■
1.21	6.05	8.50	38	3.00	2030-1.21	■
1.22	6.10	8.50	38	3.00	2030-1.22	■
1.23	6.15	8.50	38	3.00	2030-1.23	■
1.24	6.20	8.50	38	3.00	2030-1.24	■
1.25	6.25	8.50	38	3.00	2030-1.25	■
1.26	6.30	8.50	38	3.00	2030-1.26	■
1.27	6.35	8.50	38	3.00	2030-1.27	■
1.28	6.40	8.50	38	3.00	2030-1.28	■
1.29	6.45	8.50	38	3.00	2030-1.29	■
1.30	6.50	8.50	38	3.00	2030-1.30	■
1.31	6.55	8.50	38	3.00	2030-1.31	■
1.32	6.60	8.50	38	3.00	2030-1.32	■
1.33	6.65	9.50	38	3.00	2030-1.33	■
1.34	6.70	9.50	38	3.00	2030-1.34	■
1.35	6.75	9.50	38	3.00	2030-1.35	■
1.36	6.80	9.50	38	3.00	2030-1.36	■
1.37	6.85	9.50	38	3.00	2030-1.37	■
1.38	6.90	9.50	38	3.00	2030-1.38	■
1.39	6.95	9.50	38	3.00	2030-1.39	■
1.40	7.00	9.50	38	3.00	2030-1.40	■
1.41	7.05	9.50	38	3.00	2030-1.41	■
1.42	7.10	9.50	38	3.00	2030-1.42	■
1.43	7.15	9.50	38	3.00	2030-1.43	■
1.44	7.20	9.50	38	3.00	2030-1.44	■
1.45	7.25	9.50	38	3.00	2030-1.45	■
1.46	7.30	9.50	38	3.00	2030-1.46	■
1.47	7.35	9.50	38	3.00	2030-1.47	■
1.48	7.40	9.50	38	3.00	2030-1.48	■
1.49	7.45	9.50	38	3.00	2030-1.49	■
1.50	7.50	9.50	38	3.00	2030-1.50	■
1.51	7.55	10.50	38	3.00	2030-1.51	■
1.52	7.60	10.50	38	3.00	2030-1.52	■
1.53	7.65	10.50	38	3.00	2030-1.53	■
1.54	7.70	10.50	38	3.00	2030-1.54	■
1.55	7.75	10.50	38	3.00	2030-1.55	■
1.56	7.80	10.50	38	3.00	2030-1.56	■
1.57	7.85	10.50	38	3.00	2030-1.57	■
1.58	7.90	10.50	38	3.00	2030-1.58	■
1.59	7.95	10.50	38	3.00	2030-1.59	■
1.60	8.00	10.50	38	3.00	2030-1.60	■

D1 h6	L2	L3	L1	D2 h6	Art. N°	z
1.61	8.05	10.50	38	3.00	2030-1.61	■
1.62	8.10	10.50	38	3.00	2030-1.62	■
1.63	8.15	10.50	38	3.00	2030-1.63	■
1.64	8.20	10.50	38	3.00	2030-1.64	■
1.65	8.25	10.50	38	3.00	2030-1.65	■
1.66	8.30	10.50	38	3.00	2030-1.66	■
1.67	8.35	10.50	38	3.00	2030-1.67	■
1.68	8.40	10.50	38	3.00	2030-1.68	■
1.69	8.45	10.50	38	3.00	2030-1.69	■
1.70	8.50	10.50	38	3.00	2030-1.70	■
1.71	8.55	11.50	38	3.00	2030-1.71	■
1.72	8.60	11.50	38	3.00	2030-1.72	■
1.73	8.65	11.50	38	3.00	2030-1.73	■
1.74	8.70	11.50	38	3.00	2030-1.74	■
1.75	8.75	11.50	38	3.00	2030-1.75	■
1.76	8.80	11.50	38	3.00	2030-1.76	■
1.77	8.85	11.50	38	3.00	2030-1.77	■
1.78	8.90	11.50	38	3.00	2030-1.78	■
1.79	8.95	11.50	38	3.00	2030-1.79	■
1.80	9.00	11.50	38	3.00	2030-1.80	■
1.81	9.05	11.50	38	3.00	2030-1.81	■
1.82	9.10	11.50	38	3.00	2030-1.82	■
1.83	9.15	11.50	38	3.00	2030-1.83	■
1.84	9.20	11.50	38	3.00	2030-1.84	■
1.85	9.25	11.50	38	3.00	2030-1.85	■
1.86	9.30	11.50	38	3.00	2030-1.86	■
1.87	9.35	11.50	38	3.00	2030-1.87	■
1.88	9.40	11.50	38	3.00	2030-1.88	■
1.89	9.45	11.50	38	3.00	2030-1.89	■
1.90	9.50	11.50	38	3.00	2030-1.90	■
1.91	9.55	12.50	38	3.00	2030-1.91	■
1.92	9.60	12.50	38	3.00	2030-1.92	■
1.93	9.65	12.50	38	3.00	2030-1.93	■
1.94	9.70	12.50	38	3.00	2030-1.94	■
1.95	9.75	12.50	38	3.00	2030-1.95	■
1.96	9.80	12.50	38	3.00	2030-1.96	■
1.97	9.85	12.50	38	3.00	2030-1.97	■
1.98	9.90	12.50	38	3.00	2030-1.98	■
1.99	9.95	12.50	38	3.00	2030-1.99	■
2.00	10.00	12.50	38	3.00	2030-2.00	■
2.01	10.05	12.50	38	3.00	2030-2.01	■
2.02	10.10	12.50	38	3.00	2030-2.02	■
2.03	10.15	12.50	38	3.00	2030-2.03	■
2.04	10.20	12.50	38	3.00	2030-2.04	■
2.05	10.25	12.50	38	3.00	2030-2.05	■
2.06	10.30	12.50	38	3.00	2030-2.06	■
2.07	10.35	12.50	38	3.00	2030-2.07	■
2.08	10.40	12.50	38	3.00	2030-2.08	■
2.09	10.45	12.50	38	3.00	2030-2.09	■
2.10	10.50	12.50	38	3.00	2030-2.10	■
2.11	10.55	12.50	38	3.00	2030-2.11	■

D1 h6	L2	L3	L1	D2 h6	Art. N°	z
2.12	10.60	12.50	38	3.00	<b>2030-2.12</b>	■
2.13	10.65	13.50	38	3.00	<b>2030-2.13</b>	■
2.14	10.70	13.50	38	3.00	<b>2030-2.14</b>	■
2.15	10.75	13.50	38	3.00	<b>2030-2.15</b>	■
2.16	10.80	13.50	38	3.00	<b>2030-2.16</b>	■
2.17	10.85	13.50	38	3.00	<b>2030-2.17</b>	■
2.18	10.90	13.50	38	3.00	<b>2030-2.18</b>	■
2.19	10.95	13.50	38	3.00	<b>2030-2.19</b>	■
2.20	11.00	13.50	38	3.00	<b>2030-2.20</b>	■
2.21	11.05	13.50	38	3.00	<b>2030-2.21</b>	■
2.22	11.10	13.50	38	3.00	<b>2030-2.22</b>	■
2.23	11.15	13.50	38	3.00	<b>2030-2.23</b>	■
2.24	11.20	13.50	38	3.00	<b>2030-2.24</b>	■
2.25	11.25	13.50	38	3.00	<b>2030-2.25</b>	■
2.26	11.30	13.50	38	3.00	<b>2030-2.26</b>	■
2.27	11.35	13.50	38	3.00	<b>2030-2.27</b>	■
2.28	11.40	13.50	38	3.00	<b>2030-2.28</b>	■
2.29	11.45	13.50	38	3.00	<b>2030-2.29</b>	■
2.30	11.50	13.50	38	3.00	<b>2030-2.30</b>	■
2.31	11.55	13.50	38	3.00	<b>2030-2.31</b>	■
2.32	11.60	13.50	38	3.00	<b>2030-2.32</b>	■
2.33	11.65	13.50	38	3.00	<b>2030-2.33</b>	■
2.34	11.70	13.50	38	3.00	<b>2030-2.34</b>	■
2.35	11.75	13.50	38	3.00	<b>2030-2.35</b>	■
2.36	11.80	13.50	38	3.00	<b>2030-2.36</b>	■
2.37	11.85	14.50	38	3.00	<b>2030-2.37</b>	■
2.38	11.90	14.50	38	3.00	<b>2030-2.38</b>	■
2.39	11.95	14.50	38	3.00	<b>2030-2.39</b>	■
2.40	12.00	14.50	38	3.00	<b>2030-2.40</b>	■
2.41	12.05	14.50	38	3.00	<b>2030-2.41</b>	■
2.42	12.10	14.50	38	3.00	<b>2030-2.42</b>	■
2.43	12.15	14.50	38	3.00	<b>2030-2.43</b>	■
2.44	12.20	14.50	38	3.00	<b>2030-2.44</b>	■
2.45	12.25	14.50	38	3.00	<b>2030-2.45</b>	■
2.46	12.30	14.50	38	3.00	<b>2030-2.46</b>	■
2.47	12.35	14.50	38	3.00	<b>2030-2.47</b>	■
2.48	12.40	14.50	38	3.00	<b>2030-2.48</b>	■
2.49	12.45	14.50	38	3.00	<b>2030-2.49</b>	■
2.50	12.50	14.50	38	3.00	<b>2030-2.50</b>	■
2.51	12.55	14.50	38	3.00	<b>2030-2.51</b>	■
2.52	12.60	14.50	38	3.00	<b>2030-2.52</b>	■
2.53	12.65	14.50	38	3.00	<b>2030-2.53</b>	■
2.54	12.70	14.50	38	3.00	<b>2030-2.54</b>	■
2.55	12.75	14.50	38	3.00	<b>2030-2.55</b>	■
2.56	12.80	14.50	38	3.00	<b>2030-2.56</b>	■
2.57	12.85	14.50	38	3.00	<b>2030-2.57</b>	■
2.58	12.90	14.50	38	3.00	<b>2030-2.58</b>	■
2.59	12.95	14.50	38	3.00	<b>2030-2.59</b>	■
2.60	13.00	14.50	38	3.00	<b>2030-2.60</b>	■
2.61	13.05	14.50	38	3.00	<b>2030-2.61</b>	■
2.62	13.10	14.50	38	3.00	<b>2030-2.62</b>	■

D1 h6	L2	L3	L1	D2 h6	Art. N°	z
2.63	13.15	14.50	38	3.00	<b>2030-2.63</b>	■
2.64	13.20	14.50	38	3.00	<b>2030-2.64</b>	■
2.65	13.25	14.50	38	3.00	<b>2030-2.65</b>	■
2.66	13.30	16.50	38	3.00	<b>2030-2.66</b>	■
2.67	13.35	16.50	38	3.00	<b>2030-2.67</b>	■
2.68	13.40	16.50	38	3.00	<b>2030-2.68</b>	■
2.69	13.45	16.50	38	3.00	<b>2030-2.69</b>	■
2.70	13.50	16.50	38	3.00	<b>2030-2.70</b>	■
2.71	13.55	16.55	38	3.00	<b>2030-2.71</b>	■
2.72	13.60	16.50	38	3.00	<b>2030-2.72</b>	■
2.73	13.65	16.50	38	3.00	<b>2030-2.73</b>	■
2.74	13.70	16.50	38	3.00	<b>2030-2.74</b>	■
2.75	13.75	16.50	38	3.00	<b>2030-2.75</b>	■
2.76	13.80	16.50	38	3.00	<b>2030-2.76</b>	■
2.77	13.85	16.50	38	3.00	<b>2030-2.77</b>	■
2.78	13.90	16.50	38	3.00	<b>2030-2.78</b>	■
2.79	13.95	16.50	38	3.00	<b>2030-2.79</b>	■
2.80	14.00	16.50	38	3.00	<b>2030-2.80</b>	■
2.81	14.05	16.50	38	3.00	<b>2030-2.81</b>	■
2.82	14.10	16.50	38	3.00	<b>2030-2.82</b>	■
2.83	14.15	16.50	38	3.00	<b>2030-2.83</b>	■
2.84	14.20	16.50	38	3.00	<b>2030-2.84</b>	■
2.85	14.25	16.50	38	3.00	<b>2030-2.85</b>	■
2.86	14.30	16.50	38	3.00	<b>2030-2.86</b>	■
2.87	14.35	16.50	38	3.00	<b>2030-2.87</b>	■
2.88	14.40	16.50	38	3.00	<b>2030-2.88</b>	■
2.89	14.45	16.50	38	3.00	<b>2030-2.89</b>	■
2.90	14.50	16.50	38	3.00	<b>2030-2.90</b>	■
2.91	14.55	16.50	38	3.00	<b>2030-2.91</b>	■
2.92	14.60	16.50	38	3.00	<b>2030-2.92</b>	■
2.93	14.65	16.50	38	3.00	<b>2030-2.93</b>	■
2.94	14.70	16.50	38	3.00	<b>2030-2.94</b>	■
2.95	14.75	16.50	38	3.00	<b>2030-2.95</b>	■
2.96	14.80	16.50	38	3.00	<b>2030-2.96</b>	■
2.97	14.85	16.50	38	3.00	<b>2030-2.97</b>	■
2.98	14.90	16.50	38	3.00	<b>2030-2.98</b>	■
2.99	14.95	16.50	38	3.00	<b>2030-2.99</b>	■













## MICRO-LINE



## Informations techniques et symboles

## Technische Informationen und Symbole

## Technical information and symbols

<p>60° 90° 120°</p>	<p>Angle Winkel Angle</p>		<p>Coins vifs Scharfkantige Ecken Sharp corners</p>
	<p>Angle d'hélice Spiralwinkel Helix angle</p>		<p>Fraises hémisphériques Radiusfräser End mills with ball nose</p>
<p>λ 36° λ 38° λ 40°</p>	<p>Hélice différente Verschiedene Spirale Different propeller</p>		<p>Rayon de coin Eckradius Corner radius</p>
<p>λ 35°/38°</p>	<p>Hélice progressive Progressive Spirale Progressiv propeller</p>		<p>Dents avec coupe centrale Zähne Zentrumschnitt Teeth center cutting</p>
<p>Z</p>	<p>Nombre de dents Anzahl der Zähne Number of teeth</p>		<p>Denture décalée Versetzte Verzahnung Alternated teeth</p>
<p>2xD1</p>	<p>Rapport longueur-diamètre Länge-Durchmesser Verhältnis Length to diameter ratio</p>	<p>DHD</p>	<p>Denture décalée hélice différente Versetzte Verzahnung unterschiedliche Spirale Alternated teeth different helix</p>
	<p>Lèvres, affûtage à facettes Schneiden, Facettenschärfen Flutes, sharpening with facets</p>	<p>DHP</p>	<p>Denture décalée hélice progressive Versetzte Verzahnung progressive Spirale Alternated teeth progressive helix</p>
	<p>Taillage demi-lune Kanonenbohrer Spitze Gundrills tip</p>		
	<p>Taillage renforcé 3/4 3/4 genuteter Fräser 3/4 straight fluted</p>		
	<p>Usinage radial, diagonal et axial Radiale, diagonale und axiale Bearbeitung Radial, diagonal and axial machining</p>		
	<p>Usinage radial et axial Radiale und axiale Bearbeitung Radial and axial machining</p>		

## Informations techniques et symboles

## Technische Informationen und Symbole

## Technical information and symbols

Diamètre outil Werkzeugdurchmesser Tool diameter	D (mm)		
Nombre de dents Zähnezahl Number of teeth	Z		
Profondeur de coupe Schnitttiefe Cutting depth	ap (mm)		
Largeur de coupe Schnittbreite Cutting width	ae (mm)		
Vitesse de coupe Schnittgeschwindigkeit Cutting speed	(m/min)	<b>Vc =</b>	$\frac{D \times \pi \times n}{1000}$
Nombre de tours Umdrehungen Rotations	(U/min)	<b>n =</b>	$\frac{Vc \times 1000}{\pi \times D}$
Avance par dent Vorschub pro Zahn Cutting feed per tooth	(mm/tooth)	<b>fz =</b>	$\frac{Vf}{n \times Z}$
Vitesse d'avance Vorschubgeschwindigkeit Cutting feed	(mm/min)	<b>Vf =</b>	<b>fz x Z x n</b>
Débit d'enlèvement de copeaux Spanvolumen Removal of cutting up shaving	(mm <sup>3</sup> /min)	<b>Q =</b>	<b>ap x ae x Vf</b>
Avance par tour Vorschub pro Umdrehung Cutting feed per rotation	(mm/U)	<b>f =</b>	$\frac{Vf}{n}$

Nos propositions techniques s'appliquent à la plupart des utilisations courantes.

N'hésitez pas à nous contacter pour des conseils plus précis.

Diese technische Empfehlungen gelten für die Mehrzahl der Standardanwendungen.

Unsere Techniker beraten Sie gerne für spezifische Anliegen.

These technical propositions apply to the majority of standard usages.

Do not hesitate to contact us for more specific advices.

APPLITEC





Définition du nombre de dents  
Empfohlene Zähnezahl  
Recommended number of teeth > **15.02**

Conseils d'utilisation  
Anwendungsempfehlungen  
Application recommendations > **15.03**

Fraises circulaires en métal dur – denture fine  
VHM-Kreissägeblätter – feine Verzahnung  
Solid carbide slitting saws – fine teeth  
**Type 1101**  > **15.04**

Fraises circulaires en métal dur – denture grossière  
VHM-Kreissägeblätter – grobe Verzahnung  
Solid carbide slitting saws – large teeth  
**Type 1102**  > **15.06**

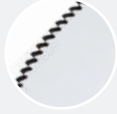
Fraises circulaires en métal dur – denture extra-fine  
VHM-Kreissägeblätter – extra feine Verzahnung  
Solid carbide slitting saws – extra fine teeth  
**Type 1103**  > **15.08**

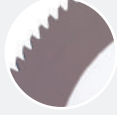
Fraises circulaires en métal dur - denture INOX  
VHM-Kreissägeblätter - INOX Verzahnung  
Solid carbide slitting saws - INOX teeth  
**Type 1104**  > **15.10**

Exécutions spéciales  
Sonderanfertigungen  
Special executions  
 > **15.11**

Disques en métal dur rectifiés  
Fertig geschliffene VHM-Ronden  
Fully ground solid carbide discs  
**Type 1106**  > **15.12**

Tasseaux porte-fraise avec serrage avant  
Fräsdorne mit Spannung von vorne  
Milling arbors with front clamping  
**Type 2810 / 2811 / 2815**  > **15.16**

Tasseaux porte-fraise avec serrage arrière  
Fräsdorne mit Spannung von hinten  
Milling arbors with rear clamping  
**Type 2820 / 1820**  > **15.17**

Définition du nombre de dents

Empfohlene Zähnezahl

Recommended number of teeth

**OK**

Idéalement 2-3 dents en contact

Im Idealfall 2-3 Zähne im Einsatz

Ideally 2-3 teeth in contact

**KO**

**Trop de dents** = avance trop faible par dent / pas assez de place pour le copeau

**Trop peu de dents** = risque de vibration / usure prématurée

**Zu viele Zähne** = zu geringer Vorschub pro Zahn / zu kleiner Spanraum

**Zu wenig Zähne** = Vibrationen / Verschleissrisiko

**Too many teeth** = feed too low per tooth / not enough place for the chips

**Not enough teeth** = vibration / risk of quick wearout

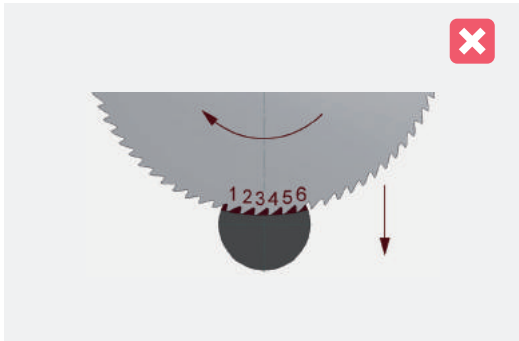
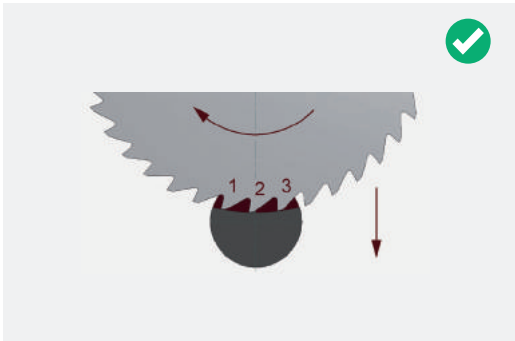
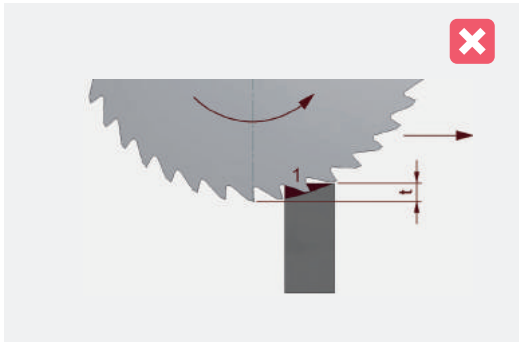
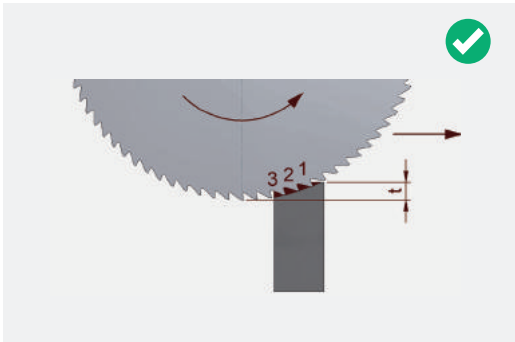
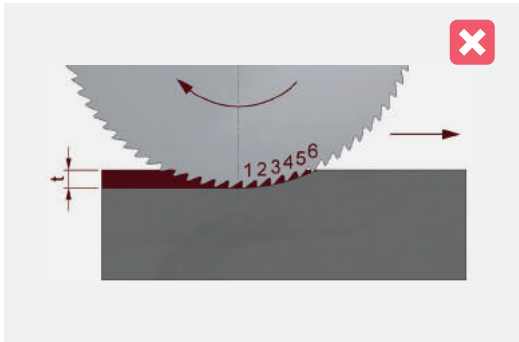
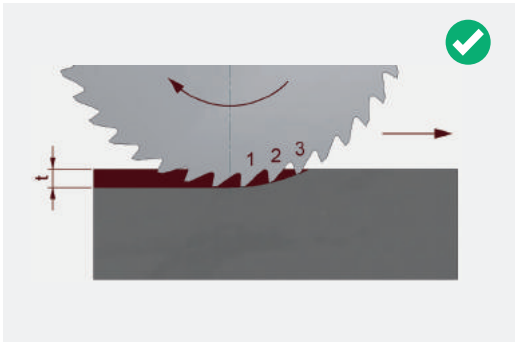

## Conseils d'utilisation

## Anwendungsempfehlungen

## Application recommendations

		Fraises circulaires en métal dur VHM-Kreissägeblätter Solid carbide slitting saws		
Matière Werkstoff Material		Lubrifiant* Kühlung* Coolant*	VC (m/min)	Choix de la denture / avance Verzahnungswahl / Vorschub Teeth selection / cutting feed
Acier de décolletage Automatenstahl Free-cutting steel	<b>P</b>	O / E	120 - 240	<p><b>Type 1101 + 1104</b></p> <ul style="list-style-type: none"> <li>• Pour usinage peu profond ou longueur à fendre faible. Avance par dent: 0.005-0.05**</li> <li>• Für geringe Bearbeitungstiefen oder kurze Schlitzlängen. Vorschub pro Zahn: 0.005-0.05**</li> <li>• For low machining depth or short slots. Feed per tooth: 0.005-0.05**</li> </ul> <p><b>Type 1102</b></p> <ul style="list-style-type: none"> <li>• Pour usinage profond ou grande longueur à fendre. Avance par dent: 0.01-0.1**</li> <li>• Für grosse Bearbeitungstiefen oder grosse Schlitzlängen. Vorschub pro Zahn: 0.01-0.1**</li> <li>• For deep machining or long slots. Feed per tooth: 0.01-0.1**</li> </ul> <p><b>Type 1103</b></p> <ul style="list-style-type: none"> <li>• Pour usinage de pièces fragiles ou fines. Avance par dent: 0.002-0.02**</li> <li>• Für die Bearbeitung von empfindlichen oder dünnwandigen Werkstücken. Vorschub pro Zahn: 0.002-0.02**</li> <li>• For machining of fragile or thin workpieces. Feed per tooth: 0.002-0.02**</li> </ul> <p>** selon la matière, l'épaisseur ainsi que la rigidité globale ** je nach Werkstoff, Dicke und Gesamtstarrheit ** according to material, thickness and global rigidity</p>
Acier Stahl Steel < 600 N/mm <sup>2</sup>	<b>P</b>	O / E	100 - 200	
Acier Stahl Steel < 800 N/mm <sup>2</sup>	<b>P</b>	O / E	80 - 160	
Acier Stahl Steel < 1000 N/mm <sup>2</sup>	<b>P</b>	O / E	60 - 120	
Acier Stahl Steel > 1000 N/mm <sup>2</sup>	<b>P</b>	O / E	40 - 80	
Fonte Gusseisen Cast iron	<b>K</b>	A / E	60 - 120	
Acier inoxydable Rostfreistahl Stainless steel	<b>M</b>	O / E	50 - 100	
Aluminium Si < 12%	<b>N</b>	O / E	150 - 600	
Aluminium Si > 12%	<b>N</b>	O / E	80 - 300	
Cuivre, laiton, bronze Kupfer, Messing, Bronze Copper, brass, bronze	<b>N</b>	A / O / E	80 - 300	
Thermoplastique Thermoplaste Thermoplastics	<b>N</b>	A	200 - 700	
Duroplastique Duroplaste Duroplastics	<b>N</b>	A	150 - 600	
Acier réfractaire Warmfester Stahl Heat resistant steel	<b>S</b>	O / E	25 - 60	
Titane Titan Titanium	<b>S</b>	O / E	30 - 60	

\* O = huile de coupe /Schneidöl / cutting oil

\* E = Emulsion

\* A = sec (air comprimé) / Trocken (Presluft) / dry (air)

avec revêtement TiN / TiCN / TiAlN, augmenter les valeurs de 20%

mit TiN / TiCN / TiAlN Beschichtung, Daten um 20% erhöhen

with TiN / TiCN / TiAlN coating, increase data by 20%

**Denture fine**  
**Feine Verzahnung**  
**Fine teeth**

**DIN 1837**

- Pour usinage peu profond ou longueur à fendre faible
- Für geringe Bearbeitungstiefen oder kurze Schlitzlängen
- For low machining depth or short slots
- Avance par dent: 0.005 - 0.05 mm
- Vorschub pro Zahn: 0.005 - 0.05 mm
- Feed per tooth: 0.005 - 0.05 mm
- Revêtement sur demande
- Beschichtung auf Anfrage
- Coating on request



Fraises circulaires en métal dur

VHM-Kreissägeblätter

Solid carbide slitting saws

Type 1101

Denture fine Feine Verzahnung Fine teeth												DIN 1837
D js12	15	20	25	30	40	50	63	80	100	125	160	D js12
d H7	5	5	8	8	10	13	16	22	22	22	32	d H7
Epaisseur Dicke Thickness E ±0.01	Z = Nombre de dents Zähnezahl Number of teeth										Epaisseur Dicke Thickness E ±0.01	
0.10	64	80	80	100	128							0.10
0.15	64	80	80	100	128							0.15
0.20	64	80	80	100	128	128	160					0.20
0.25	64	64	80	100	100	128	128					0.25
0.30	64	64	80	80	100	128	128	160				0.30
0.35	64	64	64	80	100	100	128	160				0.35
0.40	64	64	64	80	100	100	128	160				0.40
0.45	48	48	64	80	80	100	128	128				0.45
0.50	48	48	64	80	80	100	128	128	160			0.50
0.60	48	48	64	64	80	100	100	128	160	160		0.60
0.70	48	48	48	64	80	80	100	128	128	160		0.70
0.80	40	40	48	64	80	80	100	128	128	160		0.80
0.90	40	40	48	64	64	80	100	100	128	160		0.90
1.00	40	40	48	64	64	80	100	100	128	160	160	1.00
1.10	40	40	48	48	64	80	80	100	128	128		1.10
1.20	40	40	48	48	64	80	80	100	128	128	160	1.20
1.30	40	40	40	48	64	64	80	100	100			1.30
1.40	40	40	40	48	64	64	80	100	100	128		1.40
1.50	40	40	40	48	64	64	80	100	100	128	160	1.50
1.60	40	40	40	48	64	64	80	100	100	128	160	1.60
1.70	40	32	40	48	48	64	80	80	100			1.70
1.80	40	32	40	48	48	64	80	80	100	128	128	1.80
1.90	40	32	40	48	48	64	80	80	100			1.90
2.00	40	32	40	48	48	64	80	80	100	128	128	2.00
2.50	40	32	40	40	48	64	64	80	100	100	128	2.50
3.00	40	32	32	40	48	48	64	80	80	100	128	3.00
3.50	24	24	32	40	40	48	64	64	80	100		3.50
4.00	24	24	32	40	40	48	64	64	80	100		4.00
5.00	24	24	32	32	40	48	48	64	80	100		5.00
6.00	24	24	24	32	40	40	48	64	64	100		6.00

**Denture grossière**  
**Grobe Verzahnung**  
**Large teeth****DIN 1838**

- Pour usinage profond ou grande longueur à fendre
- Für grosse Bearbeitungstiefen oder grosse Schlitzlängen
- For deep machining or long slots
- Avance par dent: 0.01 - 0.1 mm
- Vorschub pro Zahn: 0.01 - 0.1 mm
- Feed per tooth: 0.01 - 0.1 mm
- Revêtement sur demande
- Beschichtung auf Anfrage
- Coating on request



Fraises circulaires en métal dur

VHM-Kreissägeblätter

Solid carbide slitting saws

Type 1102

Denture grossière Grobe Verzahnung Large teeth												DIN 1838
D js12	15	20	25	30	40	50	63	80	100	125	160	D js12
d H7	5	5	8	8	10	13	16	22	22	22	32	d H7
Epaisseur Dicke Thickness E ±0.01	Z = Nombre de dents Zähnezahl Number of teeth										Epaisseur Dicke Thickness E ±0.01	
0.20	20	20	20	30	40							0.20
0.25	20	20	20	30	40							0.25
0.30	20	20	20	30	40							0.30
0.40	20	20	20	30	40	48	64					0.40
0.50	20	20	20	30	40	48	64					0.50
0.60	20	20	20	30	40	48	48	64	80			0.60
0.70	20	20	20	30	40	40	48	64	64			0.70
0.80	20	20	20	24	32	40	48	64	64	80		0.80
0.90	20	20	20	24	32	40	48	48	64	80		0.90
1.00	20	20	20	24	32	40	48	48	64	80	80	1.00
1.20	20	20	20	24	32	40	40	48	64	64	80	1.20
1.50	20	20	20	24	32	32	40	48	48	64	80	1.50
1.60	20	20	20	24	32	32	40	48	48	64		1.60
1.80	20	20	20	24	24	32	40	40	48	64		1.80
2.00	20	20	20	24	24	32	40	40	48	64	80	2.00
2.50	20	20	20	24	24	32	32	40	48	48	80	2.50
3.00	20	20	20	24	24	24	32	40	40	48	64	3.00
4.00	20	20	20	24	20	24	32	32	40	48		4.00
5.00	20	20	20	24	20	24	24	32	40	40		5.00
6.00	20	20	20	24	20	20	24	32	32	40		6.00

Denture extra-fine  
 Extra feine Verzahnung  
 Extra fine teeth

- Pour usinage de pièces fragiles ou fines
- Avance par dent: 0.002 - 0.03 mm
- Idéal pour le décolletage
- Revêtement sur demande
- Für die Bearbeitung von empfindlichen oder dünnwandigen Werkstücken
- Vorschub pro Zahn: 0.002 - 0.03 mm
- Für Langdrehautomaten besonders empfehlenswert
- Beschichtung auf Anfrage
- For machining of fragile or thin workpieces
- Feed per tooth: 0.002 - 0.03 mm
- Recommended on automatic lathes
- Coating on request



Denture extra-fine Extra feine Verzahnung Extra fine teeth					
D js12	8	10	12	15	D js12
d H7	3	3	5	5	d H7
Epaisseur Dicke Thickness E ±0.005	$Z = \frac{\text{Nombre de dents}}{\text{Zähnezahl}} = \frac{\text{Number of teeth}}{\text{Number of teeth}}$				Epaisseur Dicke Thickness E ±0.005
0.10	48	64	64	80	0.10
0.11	48	64	64	80	0.11
0.12	48	64	64	80	0.12
0.13	48	64	64	80	0.13
0.14	48	64	64	80	0.14
0.15	48	64	64	80	0.15
0.16	48	64	64	80	0.16
0.17	48	64	64	80	0.17
0.18	48	64	64	80	0.18
0.19	48	64	64	80	0.19
0.20	48	64	64	80	0.20



Fraises circulaires en métal dur

VHM-Kreissägeblätter

Solid carbide slitting saws

Type 1103

Denture extra-fine Extra feine Verzahnung Extra fine teeth													
D js12	8	10	12	15	20	20	20	25	25	25	30	32	D js12
d H7	3	3	5	5	5	5	6	5	6	8	8	8	d H7
<b>Epaisseur Dicke Thickness E ±0.01</b>	$Z =$ Nombre de dents Zähnezahl Number of teeth											<b>Epaisseur Dicke Thickness E ±0.01</b>	
0.10	**	**	**	**			100	80	80				0.10
0.15	**	**	**	**			100	80	80	100	100	80	0.15
0.20	**	**	**	**	*		100	80	80	100	100	* 80	0.20
0.25	48	64	64	80	80		100	80	80	100	100	* 80	0.25
0.30	48	64	64	80	80		100	80	80	100	100	80	0.30
0.35	48	64	64	80	80			80	80	100	100	80	0.35
0.40	48	64	64	80	80		100	80	80	100	100	80	0.40
0.50	48	64	64	80	80		100	80	80	100	100	80	0.50
0.60	48	64	64	80	80			80	80	100	100	80	0.60
0.70	48	64	64	80	80			80	80	100	100	80	0.70
0.80	48	64	64	80	80			80	80	100	100	80	0.80
0.90	48	64	64	80	80			80	80	100	100	80	0.90
1.00	48	64	64	80	80			80	80	100	100	80	1.00
1.20				80	80			80	80	100	100	80	1.20
1.50				80	80			80	80	100	100	80	1.50
2.00				80	80			80	80	100	100	80	2.00
2.50				80	80			80	80	100	100	80	2.50
3.00				80	80			80	80	100	100	80	3.00

D js12	35	40	40	40	40	45	45	50	50	63	80	D js12
d H7	8	8	8	10	10	8	8	10	13	16	16	d H7
0.10												0.10
0.15	96	100	160	100	160	100	160					0.15
0.20	96	100	160	100	160	100	160	100				0.20
0.25	96	100	160	*	160	100	160	100	120	120		0.25
0.30	96	100	160	*	160	100	160	100	120	120		0.30
0.35	96	100	160	*	160	100	160	100	120	120		0.35
0.40	96	100	160	*	160	100	160	100	120	120		0.40
0.50	96	100	160	100	160	100	160	100	120	120	128	0.50
0.60	96	100	160	100	160	100	160	100	120	120	128	0.60
0.70	96	100	160	100	160	100	160	100	120	120	128	0.70
0.80	96	100	160	100	160	100	160	100	120	120	128	0.80
0.90	96	100	160	100	160	100	160	100	120	120	128	0.90
1.00	96	100	160	100	160	100	160	100	120	120	128	1.00
1.20	96	100	160	100	160	100	160	100	120	120	128	1.20
1.50	96	100	160	100	160	100	160	100	120	120	128	1.50
2.00	96	100	160	100	160	100	160	100	120	120	128	2.00
2.50	96	100	160	100	160	100	160	100	120	120	128	2.50
3.00	96	100	160	100	160	100	160	100	120	120	128	3.00

\*\* voir page 15.08 / siehe Seite 15.08 / see page 15.08

\* voir type 1101 / siehe Typ 1101 / see type 1101

Denture fine  
Feine Verzahnung  
Fine teeth

DIN 1837

- Pour usinage peu profond ou longueur à fendre faible
- Für geringe Bearbeitungstiefen oder kurze Schlitzlängen
- For low machining depth or short slots
- Avance par dent: 0.005 - 0.05 mm
- Vorschub pro Zahn: 0.005 - 0.05 mm
- Feed per tooth: 0.005 - 0.05 mm

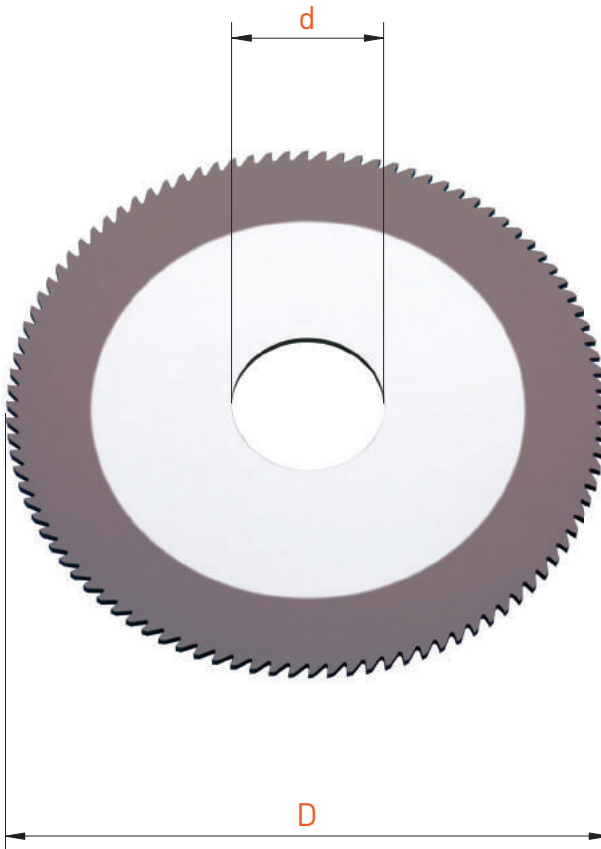

Fraises circulaires en métal dur

VHM-Kreissägeblätter

Solid carbide slitting saws

Type 1104

Denture INOX INOX Verzahnung INOX teeth				DIN 1837	
D js12	63	80	100	D js12	MAXINOX
d H7	16	22	22	d H7	
<b>Epaisseur Dicke Thickness</b> E ±0.01	Z = Nombre de dents Zähnezahl Number of teeth			<b>Epaisseur Dicke Thickness</b> E ±0.01	
<b>0.80</b>	80	100	120	<b>0.80</b>	■
<b>1.00</b>	80	100	120	<b>1.00</b>	■

Exécutions spéciales

Sonderanfertigungen

Special executions

- Denture forme B
- Denture forme W
- Train de fraises
- Alésage avec entrée de clavette
- Autres exécutions spéciales sur demande
- Revêtement sur demande

- B Zahnform
- W Zahnform
- Spezielle Kreissägeblätter im Satz
- Bohrung mit Keilnute
- Andere Sonderanfertigungen auf Anfrage
- Beschichtung auf Anfrage

- Tooth form B
- Tooth form W
- Special slitting saws in set
- Bore with keyway
- Other special executions on request
- Coating on request

**Prêt pour le taillage de la denture**  
**Bereit zum Verzahnen**  
**Ready for teeth grinding**

- Finition poli miroir des deux faces avec dépouille
- Alésage tolérance H7
- Diamètre surdimensionné ~0.15 mm
- Hochglanz Seiten mit Hohlchliff
- H7 Bohrung Toleranz
- Aussendurchmesser mit ~0.15 mm Übermass
- Mirror finish on both sides with clearance
- Bore with H7 tolerance
- Outside diameter with ~0.15 mm oversize



Disques en métal dur rectifiés

Fertig geschliffene VHM-Ronden

Fully ground solid carbide discs

Ø 8-35 mm

Type 1106

Prêt pour le taillage de la denture Bereit zum Verzahnen Ready for teeth grinding													
D +0.15/0	8	10	12	15	20	20	25	25	25	30	32	35	D ±0.15
d H7	3	3	5	5	5	6	5	6	8	8	8	8	d H7
Epaisseur Dicke Thickness E ±0.01	Epaisseurs et alésages spéciaux sur demande Andere Dicken und Bohrungen auf Anfrage Other thicknesses and bores on request											Epaisseur Dicke Thickness E ±0.01	
0.10	■	■	■	■	■	■	■	■	■	■			0.10
0.15	■	■	■	■	■	■	■	■	■	■	■	■	0.15
0.20	■	■	■	■	■	■	■	■	■	■	■	■	0.20
0.25	■	■	■	■	■	■	■	■	■	■	■	■	0.25
0.30	■	■	■	■	■	■	■	■	■	■	■	■	0.30
0.35	■	■	■	■	■	■	■	■	■	■	■	■	0.35
0.40	■	■	■	■	■	■	■	■	■	■	■	■	0.40
0.45	□	□	□	■	■	■	■	□	■	■	□	■	0.45
0.50	■	■	■	■	■	■	■	■	■	■	■	■	0.50
0.60	■	■	■	■	■	■	■	■	■	■	■	■	0.60
0.70	■	■	■	■	■	■	■	■	■	■	■	■	0.70
0.80	■	■	■	■	■	■	■	■	■	■	■	■	0.80
0.90	■	■	■	■	■	■	■	■	■	■	■	■	0.90
1.00	■	■	■	■	■	■	■	■	■	■	■	■	1.00
1.10			□	■	■	□	□	□	■	■	□	□	1.10
1.20			□	■	■	■	■	■	■	■	■	■	1.20
1.30			□	■	■	□	□	□	■	■	□	□	1.30
1.40			□	■	■	□	□	□	■	■	□	□	1.40
1.50			■	■	■	■	■	■	■	■	■	■	1.50
1.60				■	■	□	□	□	■	■	□	□	1.60
1.70				■	■	□	□	□	■	■	□	□	1.70
1.80				■	■	□	□	□	■	■	□	□	1.80
1.90				■	■	□	□	□	■	■	□	□	1.90
2.00				■	■	■	■	■	■	■	■	■	2.00
2.50				■	■	■	■	■	■	■	■	■	2.50
3.00				■	■	■	■	■	■	■	■	■	3.00
3.50				□	□				□	□			3.50
4.00				□	□				□	□			4.00
5.00				□	□				□	□			5.00
6.00				□	□				□	□			6.00

■ = disponible / verfügbar / available

□ = selon disponibilité du stock / jenach Lagerverfügbarkeit / depending on stock availability

**Prêt pour le taillage de la denture**  
**Bereit zum Verzahnen**  
**Ready for teeth grinding**

- Finition poli miroir des deux faces avec dépouille
- Alésage tolérance H7
- Diamètre surdimensionné ~0.15 mm
- Hochglanz Seiten mit Hohlchliff
- H7 Bohrung Toleranz
- Aussendurchmesser mit ~0.15 mm Übermass
- Mirror finish on both sides with clearance
- Bore with H7 tolerance
- Outside diameter with ~0.15 mm oversize

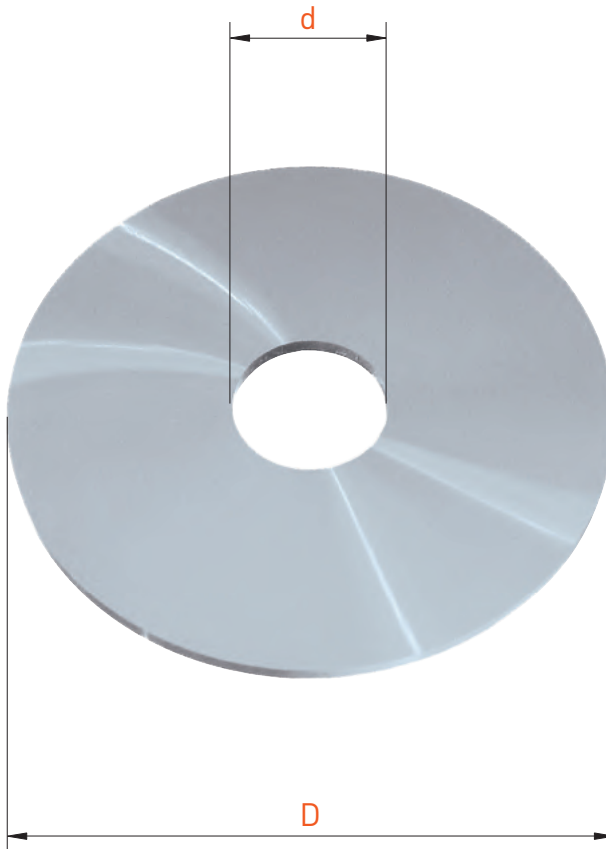

Disques en métal dur rectifiés

Fertig geschliffene VHM-Ronden

Fully ground solid carbide discs

Ø 40-160 mm

Type 1106

Prêt pour le taillage de la denture Bereit zum Verzahnen Ready for teeth grinding													
D +0.15/0	40	40	45	50	50	63	80	80	100	125	160	160	D ±0.15
d H7	8	10	8	10	13	16	16	22	22	22	22	32	d H7
Epaisseur Dicke Thickness E ±0.01	Epaisseurs et alésages spéciaux sur demande Andere Dicken und Bohrungen auf Anfrage Other thicknesses and bores on request											Epaisseur Dicke Thickness E ±0.01	
0.10		■											0.10
0.15	■	■	■										0.15
0.20	■	■	■	■	■	■							0.20
0.25	■	■	■	■	■	■							0.25
0.30	■	■	■	■	■	■		■					0.30
0.35	■	■	■	■	■	■		■					0.35
0.40	■	■	■	■	■	■		■					0.40
0.45	■	■	□	□	■	■		■					0.45
0.50	■	■	■	■	■	■	■	■	□				0.50
0.60	■	■	■	■	■	■	■	■	□	□			0.60
0.70	■	■	■	■	■	■	■	■	□	□			0.70
0.80	■	■	■	■	■	■	■	■	□	□			0.80
0.90	■	■	■	■	■	■	■	■	□	□			0.90
1.00	■	■	■	■	■	■	■	■	□	□		□	1.00
1.10	□	■	□	□	■	■	□	■	□	□		□	1.10
1.20	■	■	■	■	■	■	■	■	□	□	□	□	1.20
1.30	■	■	□	□	■	■	□	■	□	□		□	1.30
1.40	■	■	□	□	■	■	□	■	□	□		□	1.40
1.50	■	■	■	■	■	■	■	■	□	□	□	□	1.50
1.60	□	■	□	□	■	■	□	□	□	□		□	1.60
1.70	□	■	□	□	■	■	□	□	□	□		□	1.70
1.80	□	■	□	□	■	■	□	□	□	□		□	1.80
1.90	□	■	□	□	■	■	□	□	□	□		□	1.90
2.00	■	■	■	■	■	■	□	□	□	□		□	2.00
2.50	■	■	■	■	■	■	□	□	□	□		□	2.50
3.00	■	■	■	■	■	■	□	□	□	□		□	3.00
3.50		□			□	□		□	□	□			3.50
4.00		□			□	□		□	□	□			4.00
5.00		□			□	□		□	□	□			5.00
6.00		□			□	□		□	□	□			6.00

■ = disponible / verfügbar / available

□ = selon disponibilité du stock / jenach Lagerverfügbarkeit / depending on stock availability

Tasseaux porte-fraise avec serrage avant  
 Fräsdorne mit Spannung von vorne  
 Milling arbors with front clamping

## Type 2810 / 2811 / 2815

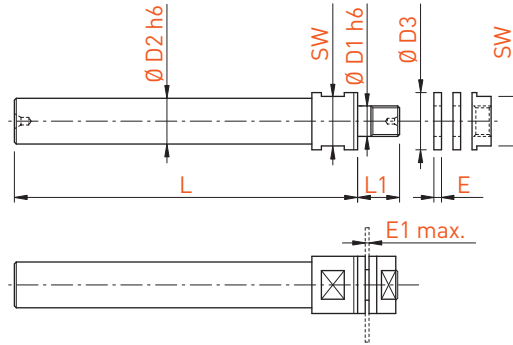

Type 2810	Rotation à droite (filet à droite) Drehrichtung rechts (Rechtsgewinde) Right hand rotation (right hand thread)							
D1 h6	D2 h6	D3	L	L1	E	SW	E1 max.	Art. N°
5.0	6.0	10.0	70	9.0	2.0	8.0	6.0	2810-5-6
5.0	10.0	10.0	80	9.0	2.0	8.0	6.0	2810-5-10
6.0	10.0	12.0	80	9.5	2.0	10.0	6.0	2810-6-10
8.0	10.0	15.0	80	10.0	2.0	13.0	6.0	2810-8-10
8.0	12.0	15.0	90	10.0	2.0	13.0	6.0	2810-8-12
10.0	6.0	18.0	80	10.5	2.0	15.0	6.0	2810-10-6
10.0	10.0	18.0	80	10.5	2.0	15.0	6.0	2810-10-10
10.0	16.0	18.0	100	10.5	2.0	15.0	6.0	2810-10-16
13.0	16.0	22.0	110	11.0	2.0	19.0	6.0	2810-13-16
16.0	20.0	26.0	120	12.0	2.0	22.0	6.0	2810-16-20
22.0	16.0	32.0	120	12.0	2.0	27.0	6.0	2810-22-16

Type 2811	Rotation à droite (filet à droite) Drehrichtung rechts (Rechtsgewinde) Right hand rotation (right hand thread)							
D1 h6	D2 h6	D3	L	L1	E	SW	E1 max.	Art. N°
16.0	10.0	22.0	80	8.0	2.0	19.0	3.0	2811-16-10

Type 2815	Pour petites fraises circulaires (filet à droite) Für kleine Kreissägeblätter (Rechtsgewinde) For small slitting saws (right hand thread)							
D1 h6	D2 h6	D3	L	L1	E	SW	E1 max.	Art. N°
3.0	5.0	5.0	60	7.0	1.0	4.0	3.0	2815-3-5
5.0	6.0	7.5	70	7.0	1.0	6.0	3.0	2815-5-6



Tasseaux porte-fraise avec serrage arrière

Fräsdorne mit Spannung von hinten

Milling arbors with rear clamping

Type 2820 / 1820

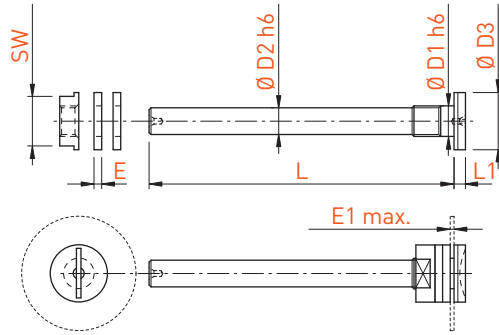

Type 2820	Rotation à droite (filet à gauche) Drehrichtung rechts (Linksgewinde) Right hand rotation (left hand thread)							
	D1 h6	D2 h6	D3	L	L1	E	SW	E1 max.
5.0	4.0	10.0	50	3.0	2.0	8.0	6.0	2820-5-4
6.0	5.0	12.0	60	3.0	2.0	10.0	6.0	2820-6-5
8.0	6.0	15.0	80	3.0	2.0	13.0	6.0	2820-8-6
8.0	7.0	15.0	80	3.0	2.0	13.0	6.0	2820-8-7
10.0	6.0	18.0	70	3.5	2.0	15.0	6.0	2820-10-6
10.0	8.0	18.0	90	3.5	2.0	15.0	6.0	2820-10-8
13.0	10.0	22.0	110	3.5	2.0	19.0	6.0	2820-13-10
16.0	12.0	26.0	120	3.5	2.0	22.0	6.0	2820-16-12

Type 1820	Rotation à gauche (filet à droite) Drehrichtung links (Rechtsgewinde) Left hand rotation (right hand thread)							
	D1 h6	D2 h6	D3	L	L1	E	SW	E1 max.
5.0	4.0	10.0	50	3.0	2.0	8.0	6.0	1820-5-4
6.0	5.0	12.0	60	3.0	2.0	10.0	6.0	1820-6-5
8.0	6.0	15.0	70	3.0	2.0	13.0	6.0	1820-8-6
10.0	6.0	18.0	70	3.5	2.0	15.0	6.0	1820-10-6

Chaque tasseau est livré avec 2 entretoises et 1 écrou

Jeder Fräsdorn wird mit 2 Abstandsringen und 1 Mutter geliefert

2 distance rings and 1 nut are included with each arbor

Pièces de rechange Ersatzteile Spare parts	E	Art. N°	Art. N°
	2	2810-D1*-A	2810-D1*-B
	2	2811-D1*-A	2811-D1*-B
	1	2815-D1*-A	2815-D1*-B
	2	2820-D1*-A	2820-D1*-B

\* Diamètre D1 à spécifier \* Durchmesser D1 angeben \* Diameter D1 to be specified



**Réduisez le temps de changement d'outil jusqu'à 75%!**  
**Reduzieren Sie die Wechselzeit Ihrer IK-Halter um bis zu 75%!**  
**Reduce tool change time by up to 75%!**

Le système de distribution de réfrigérant Applitec JET-LINE est conçu pour tirer parti de tous les avantages offerts par le refroidissement à haute pression jusqu'à 220 bar. Associé à nos porte-outils, il permet des préparations rapides et flexibles tout en garantissant l'orientation et la quantité correcte de débit de l'agent de refroidissement directement sur l'outil de coupe!

Mit dem Applitec Hochdruckkühlmittelsystem JET-LINE profitieren Sie von einer effizienten Kühlmittelversorgung Ihrer IK-Werkzeuge bis zu 220 bar. In Verbindung mit den IK-Haltern von Applitec wird ein schneller, und flexibler Werkzeugwechsel ermöglicht!

Applitec JET-LINE coolant distribution system is designed to maximise the benefits and advantages offered by high pressure coolant up to 220 bar. Associated to our holders with intergrated coolant, the quick change and flexible system reduces set up times without compromising the correct orientation and quantity of coolant flow directly to the cutting tool!

## Les avantages

## Die Vorteile

## The advantages

### Changement rapide Schnellwechselsystem Quick change

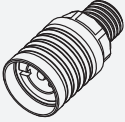

Réduit le temps de préparation et garantit le repositionnement des sorties de liquide de refroidissement  
Verkürzung der Rüstzeiten bei gleicher Position der Kühlmittelauslässe  
Reduces set up times with coolant outlets remain in the same position

### Refroidissement à haute pression Hochdruck abgekühlt High pressure



Tuyaux flexibles renforcés garantis jusqu'à 220 bar !  
Hochdruck verstärkten Schläuchen bis 220 bar !  
High pressure flexible reinforced hoses up to 220 bar !

### Facilité d'adaptation Einfache Anpassungsmöglichkeiten Easy to adapt

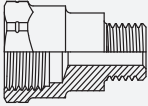

Adaptateur disponible pour filetage M5, M6, M8X1 and BSP1/8  
Adapter für M5, M6, M8X1 und BSP1/8 erhältlich  
Adaptors available for M5, M6, M8X1, and BSP1/8 thread

### Multiples possibilités de connexion Vielfältige Anschlussoptionen Large range of connection possibilities

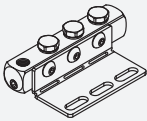





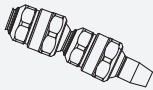





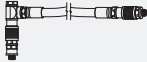



Vaste gamme de connecteurs pour tous les types de machines  
Grosse Auswahl von Anschlüsse für alle Machinentypen  
Huge range of possible coolant connections to suit all machine types

### Système articulé Gelenksystem Articulated system



Module flexible d'arrosage en acier pour une meilleure stabilité  
Flexibler Stahlkühlmittelmodul für eine bessere Stabilität  
Flexible steel coolant unit for better stability





Augmentation de la durée de vie et une meilleure efficacité de l'outil dû au contrôle des copeaux  
JET-LINE steigert die Lebensdauer der Werkzeuge und verbessert die Spankontrolle  
Increased tool life with better swarf control

<b>JKIT</b>			> <b>16.04</b>
<b>STARTER-KIT</b>			> <b>16.12</b>
<b>JS</b>	Raccords rapides Schnellkupplungen Quick connectors		> <b>16.14</b>
<b>JO</b>	Joints d'étanchéité en cuivre Kupferdichtungsringe Copper sealing gaskets		> <b>16.15</b>
<b>JTX-AC</b>	Tubes de distribution flexibles en acier inoxydable tressé Rostfreier Stahlflex-Schlauch Flexible distribution tubes of stainless steel braiding		> <b>16.16</b>
<b>JT-CU</b>	Tubes de distribution en cuivre Kupferrohre Copper distribution tubes		> <b>16.17</b>
<b>JRMF</b>	Connecteurs mâle/femelle Gewindeadapter Innen und Außengewinde Male/female connectors		> <b>16.18</b>
<b>JRFF</b>	Connecteurs femelle/femelle Gewindeadapter Innengewinde Female connectors		> <b>16.20</b>
<b>JRMM</b>	Connecteurs mâle/mâle Gewindeadapter Außengewinde Male connectors		> <b>16.21</b>
<b>JN</b>	Écrous d'étanchéité Dichtungsmutter Sealing nuts		> <b>16.22</b>
<b>JNG</b>	Bague d'étanchéité Dichtungsring Sealing ring		> <b>16.23</b>
<b>JCBF</b>	Banjos courts femelle Kurzer Innengewindeadapter Short female Banjo		> <b>16.24</b>
<b>JCBM</b>	Banjos courts mâle Kurzer Aussengewindeadapter Short Banjo		> <b>16.25</b>
<b>JABF</b>	Banjos longs droits femelle Langer Innengewindeadapter Long straight female banjos		> <b>16.26</b>
<b>JABF-45°</b>	Banjos longs coudés femelle Adapter lang 45° Innengewinde Long curved female banjos		> <b>16.27</b>

<b>JEB</b>	Vis banjo Hohlschrauben einfach Banjo screws		> <b>16.28</b>
<b>JEB-DUO</b>	Vis banjo double Hohlschrauben doppelt Double banjo screws		> <b>16.29</b>
<b>JVB</b>	Fiches de verrouillage Verschlußstecker Sealing connecting plugs		> <b>16.30</b>
<b>JVF</b>	Fiches de connexion Innengewindestecker Connecting plugs		> <b>16.31</b>
<b>JWF</b>	Fiches de connexion fixes femelle Innengewindestecker mit Verdrehsicherung Female positioning connection plugs		> <b>16.32</b>
<b>JWM</b>	Fiches de connexion fixes mâle Aussengewindestecker mit Verdrehsicherung Male positioning connection plugs		> <b>16.33</b>
<b>JK</b>	Blocs de distribution Kühlmittelverteiler Distribution blocks		> <b>16.34</b>
<b>JBB</b>	Bouchons d'étanchéité Verschlußstopfen Sealing plugs		> <b>16.35</b>

*Système articulé avec arrosage / Gelenksystem mit Kühlung / Articulated system with coolant*



<b>JKIT-AR</b>	Kit articulé avec buse d'arrosage Gelenkkit mit Kühlungsdüse Articulated kit with coolant nozzle		> <b>16.36</b>
<b>JKIT-CU</b>	Kit tube en cuivre avec buse d'arrosage Kit Kupferrohr mit Kühlungsdüse Kit copper tube with coolant nozzle		> <b>16.38</b>
<b>JAR</b>	Système articulé Gelenksystem Articulated system		> <b>16.39</b>
<b>JRMM-AR</b>	Connecteurs mâle/mâle Anschlüsse Aussengewinde Male connectors		> <b>16.40</b>
<b>JJ-AR</b>	Buses Düse Nozzle		> <b>16.41</b>
<b>ACCESSOIRES</b>			> <b>16.43</b>

# JET-LINE

Kit de connexion

Verbindungskit

Connection kit

Quick / Fix

M5

JKIT-M5-D4-...-QF

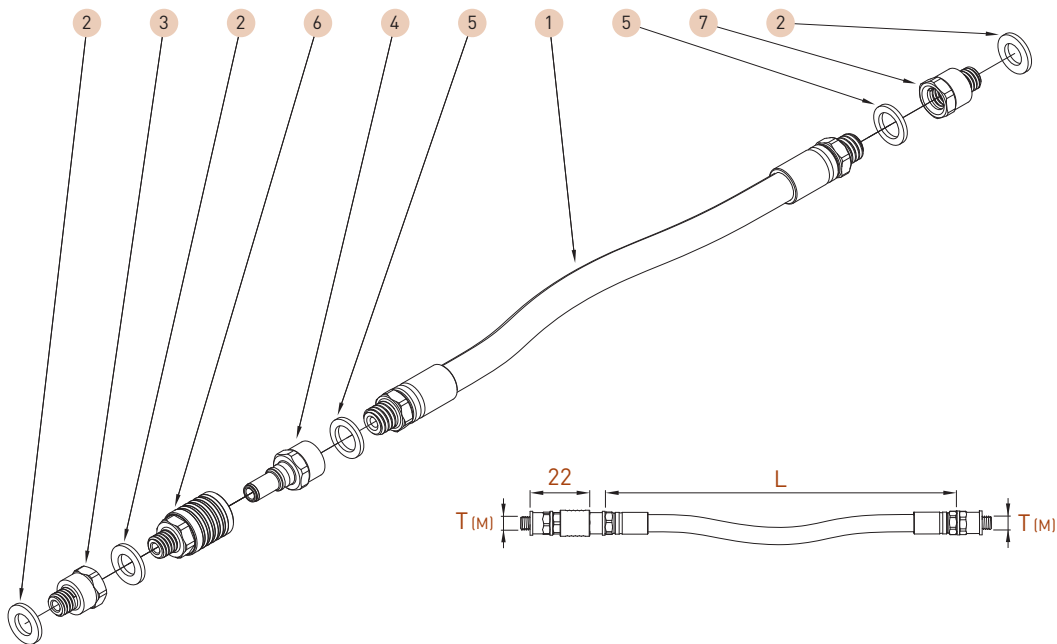

Ref	Qty	Kit composition
1	1	JTX-AC-M6-L...
2	3	JO-M5
3	1	JRMF-M5-M5-L6.5
4	1	JVF-M6-D4
5	2	JO-M6
6	1	JS-M5-D4
7	1	JRMF-M5-M6-L7.5

D	T (M)	L	Art. N°
4	M5	102	JKIT-M5-D4-102-QF
		203	JKIT-M5-D4-203-QF
		305	JKIT-M5-D4-305-QF
		406	JKIT-M5-D4-406-QF

Compatibilité  
Kompatibilität  
Compatibility



Porte-outil/Halter/Holder M5

ISO-Line 8X10  
MODU-Line  
TOP-Line 8X10  
TURN-Line 8X10

Options



Art. N°

JK-M5-1010-4T

voir page 16.34  
siehe Seite 16.34  
see page 16.34



Art. N°

C-SW8-E2.5

voir page 16.45  
siehe Seite 16.45  
see page 16.45

Kit de connexion

Verbindungsakit Quick / Quick

Connection kit

M5

JKIT-M5-D4-...-QQ

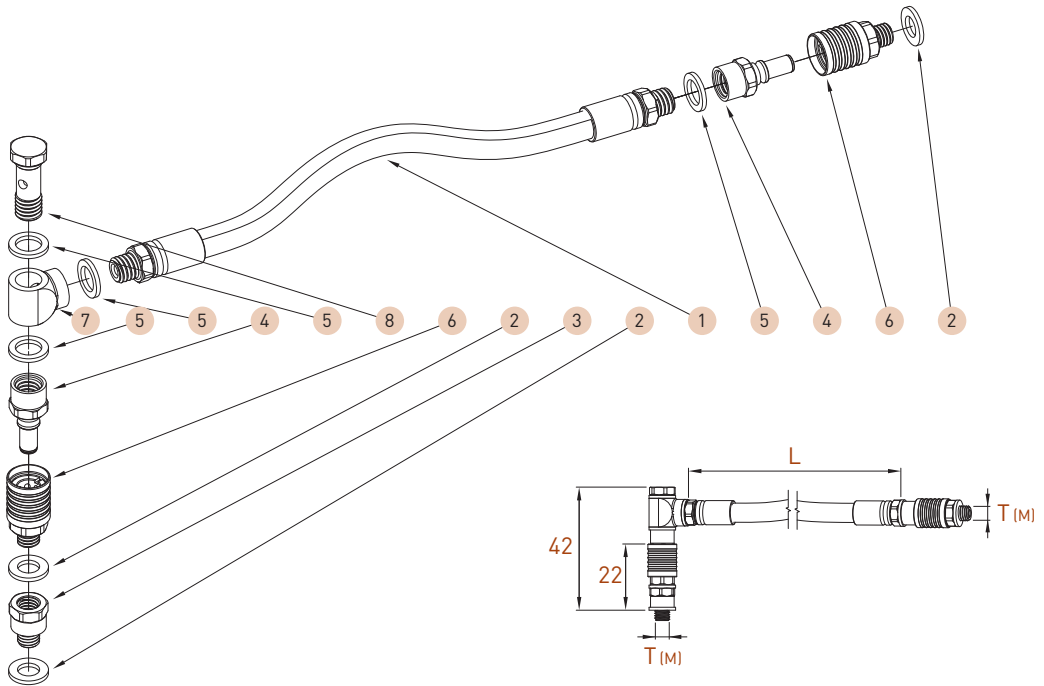

Ref	Qty	Kit composition
1	1	JTX-AC-M6-L...
2	3	JO-M5
3	1	JRMF-M5-M5-L6.5
4	2	JVF-M6-D4
5	4	JO-M6
6	2	JS-M5-D4
7	1	JCBF-Ø6-M6
8	1	JEB-M6-L19

D	T (M)	L	Art. N°
4	M5	102	JKIT-M5-D4-102-QQ
		203	JKIT-M5-D4-203-QQ
		305	JKIT-M5-D4-305-QQ
		406	JKIT-M5-D4-406-QQ

Compatibilité  
Kompatibilität  
Compatibility



Porte-outil/Halter/Holder M5

ISO-Line 8X10  
MODU-Line  
TOP-Line 8X10  
TURN-Line 8X10

Options



Art. N°

JK-M5-1010-4T

voir page 16.34  
siehe Seite 16.34  
see page 16.34

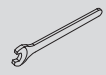

Art. N°

C-SW8-E2.5

voir page 16.45  
siehe Seite 16.45  
see page 16.45

Kit de connexion

Verbindungskit

Connection kit

Quick / Fix

M6

JKIT-M6-D4-...-QF

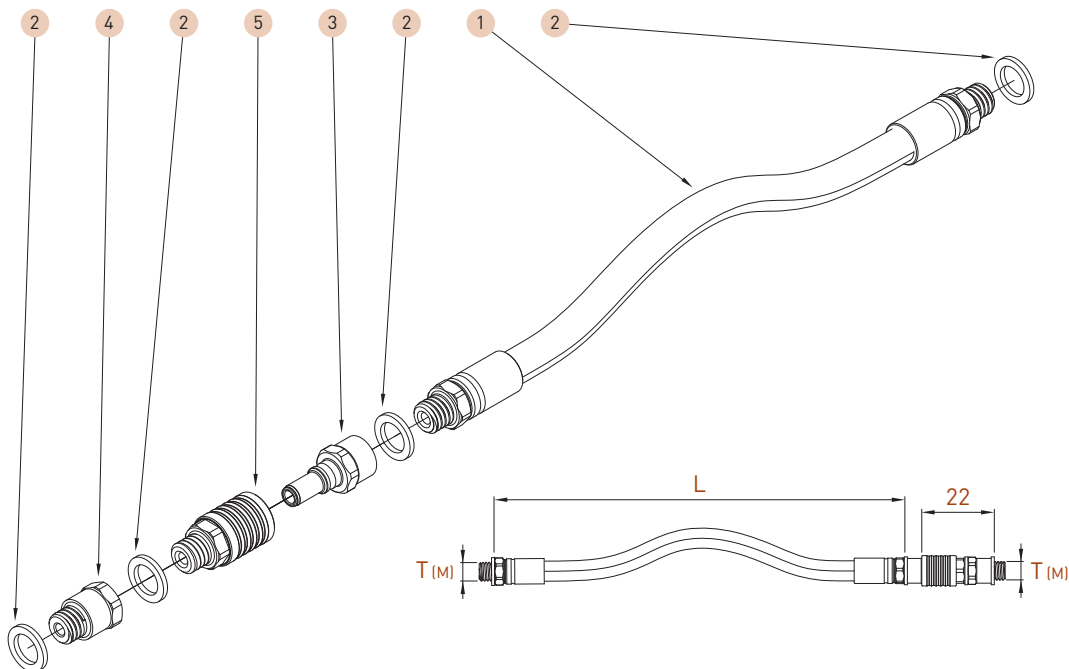

Ref	Qty	Kit composition
1	1	JTX-AC-M6-L...
2	4	JO-M6
3	1	JVF-M6-D4
4	1	JRMF-M6-M6-L7.5
5	1	JS-M6-D4

D	T (M)	L	Art. N°
4	M6	102	JKIT-M6-D4-102-QF
		203	JKIT-M6-D4-203-QF
		305	JKIT-M6-D4-305-QF
		406	JKIT-M6-D4-406-QF

Compatibilité  
Kompatibilität  
Compatibility



Porte-outil/Halter/Holder M6

Options



Art. N°

JK-M6-1010-4T

voir page 16.34  
siehe Seite 16.34  
see page 16.34



Art. N°

C-SW8-E2.5

voir page 16.45  
siehe Seite 16.45  
see page 16.45



Kit de connexion

Verbindungskit Quick / Quick

Connection kit

M6

JKIT-M6-D4-...-QQ

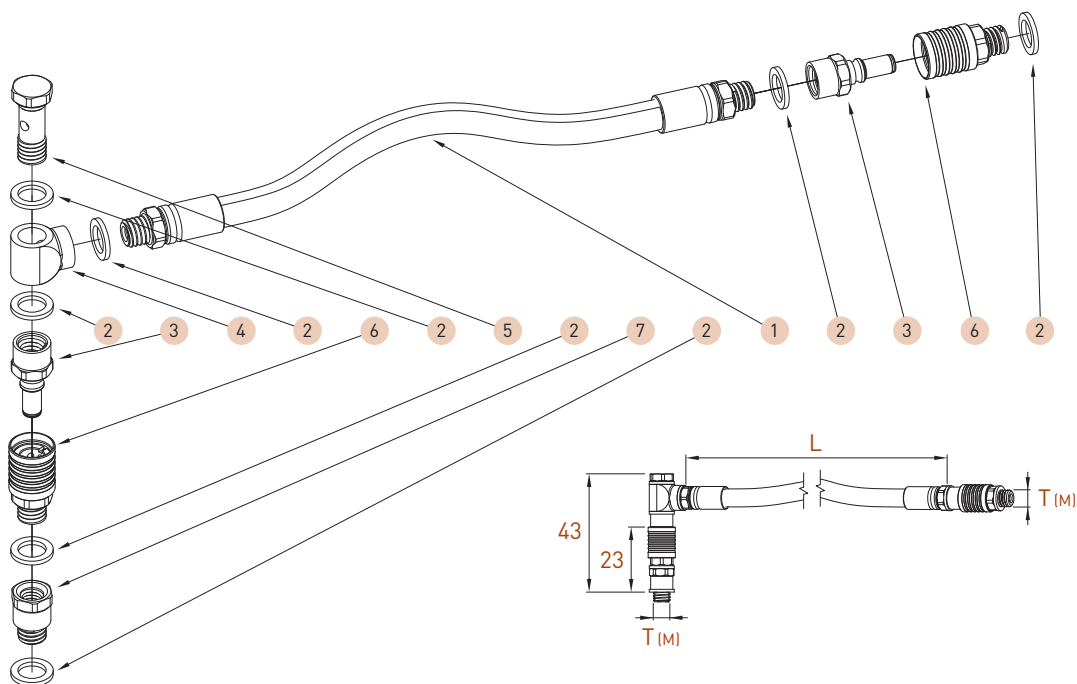

Ref	Qty	Kit composition
1	1	JTX-AC-M6-L...
2	7	JO-M6
3	2	JVF-M6-D4
4	1	JCBF-Ø6-M6
5	1	JEB-M6-L19
6	2	JS-M6-D4
7	1	JRMF-M6-M6-L7.5

D	T (M)	L	Art. N°
4	M6	102	JKIT-M6-D4-102-QQ
		203	JKIT-M6-D4-203-QQ
		305	JKIT-M6-D4-305-QQ
		406	JKIT-M6-D4-406-QQ

Compatibilité  
Kompatibilität  
Compatibility



Porte-outil/Halter/Holder M6

Options



Art. N°

JK-M6-1010-4T

voir page 16.34  
siehe Seite 16.34  
see page 16.34



Art. N°

C-SW8-E2.5

voir page 16.45  
siehe Seite 16.45  
see page 16.45

# JET-LINE

Kit de connexion

Verbindungskit

Connection kit

Quick / Fix

M8X1

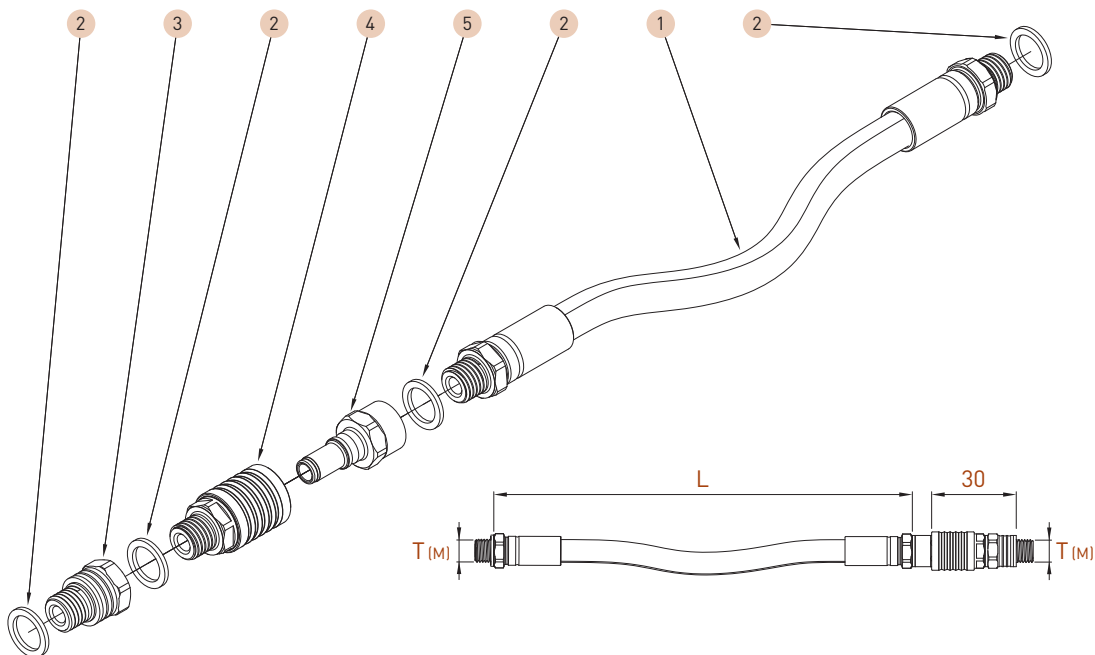

JKIT-M8X1-D6-...-QF



Ref	Qty	Kit composition
1	1	JTX-AC-M8X1-L...
2	4	JO-M8X1
3	1	JRMF-M8X1-M8X1-L9.5
4	1	JS-M8X1-D6
5	1	JVF-M8X1-D6

D	T (M)	L	Art. N°
6	M8X1	102	JKIT-M8X1-D6-102-QF
		203	JKIT-M8X1-D6-203-QF
		305	JKIT-M8X1-D6-305-QF
		406	JKIT-M8X1-D6-406-QF

Compatibilité Kompatibilität Compatibility	Porte-outil/Halter/Holder M8X1	
	 <p>CUT-Line 16X16 - 25X25 ECO-Line 10X12 - 20X20 EVOCUT-Line 10X12 - 20X20 IN-Line Ø12 - Ø28 ISO-Line 10X10 - 20X20 MODU-Line PRO-Line 10X12 - 20X20 TOP-Line 10X12 - 20X20 TURN-Line 10X12 - 20X20</p>	

Options	Options	
	 <p>Art. N° <b>JK-M8X1-1515-4T</b> voir page 16.34 siehe Seite 16.34 see page 16.34</p>	 <p>Art. N° <b>C-SW11-E3.7</b> voir page 16.45 siehe Seite 16.45 see page 16.45</p>

**Kit de connexion**

**Verbindungskit Quick / Quick**

**Connection kit**

**M8X1**

**JKIT-M8X1-D6-...-QQ**

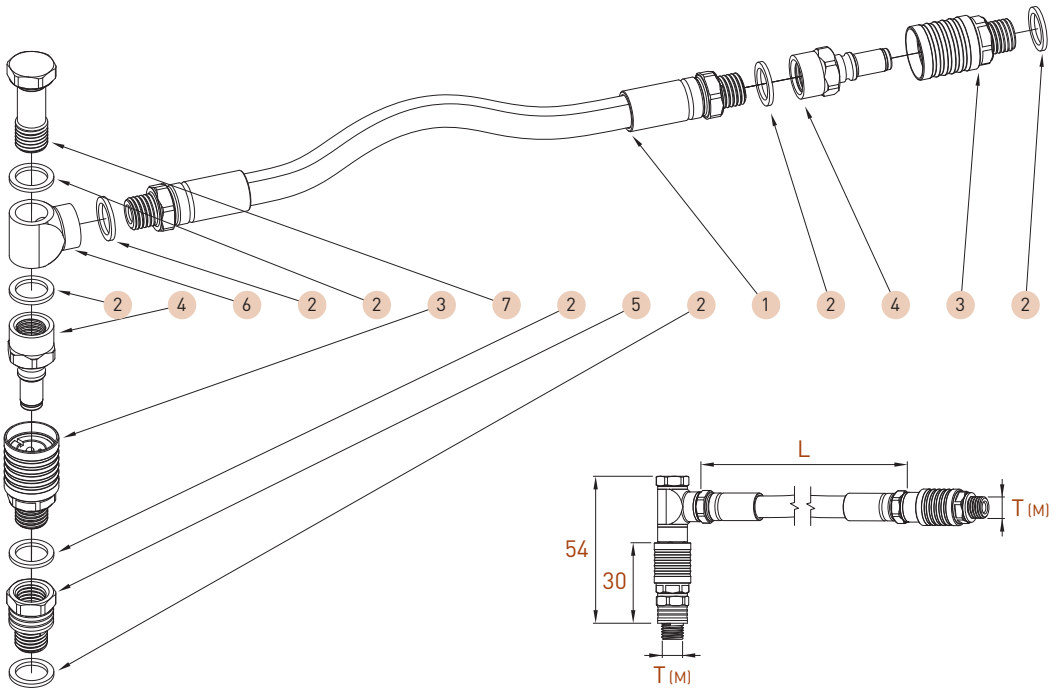

Ref	Qty	Kit composition
1	1	JTX-AC-M8X1-L...
2	7	JO-M8X1
3	2	JS-M8X1-D6
4	2	JVF-M8X1-D6
5	1	JRMF-M8X1-M8X1-L9,5
6	1	JCBF-Ø8-M8X1
7	1	JEB-M8X1-L24

D	T (M)	L	Art. N°
6	M8X1	102	<b>JKIT-M8X1-D6-102-QQ</b>
		203	<b>JKIT-M8X1-D6-203-QQ</b>
		305	<b>JKIT-M8X1-D6-305-QQ</b>
		406	<b>JKIT-M8X1-D6-406-QQ</b>

**Porte-outil/Halter/Holder M8X1**

Compatibilité  
Kompatibilität  
Compatibility

- CUT-Line 16X16 - 25X25
- ECO-Line 10X12 - 20X20
- EVO-CUT-Line 10X12 - 20X20
- IN-Line Ø12 - Ø28
- ISO-Line 10X10 - 20X20
- MODU-Line
- PRO-Line 10X12 - 20X20
- TOP-Line 10X12 - 20X20
- TURN-Line 10X12 - 20X20

**Options**

Art. N°	Art. N°
<b>JK-M8X1-1515-4T</b>	<b>C-SW11-E3.7</b>
voir page 16.34 siehe Seite 16.34 see page 16.34	voir page 16.45 siehe Seite 16.45 see page 16.45

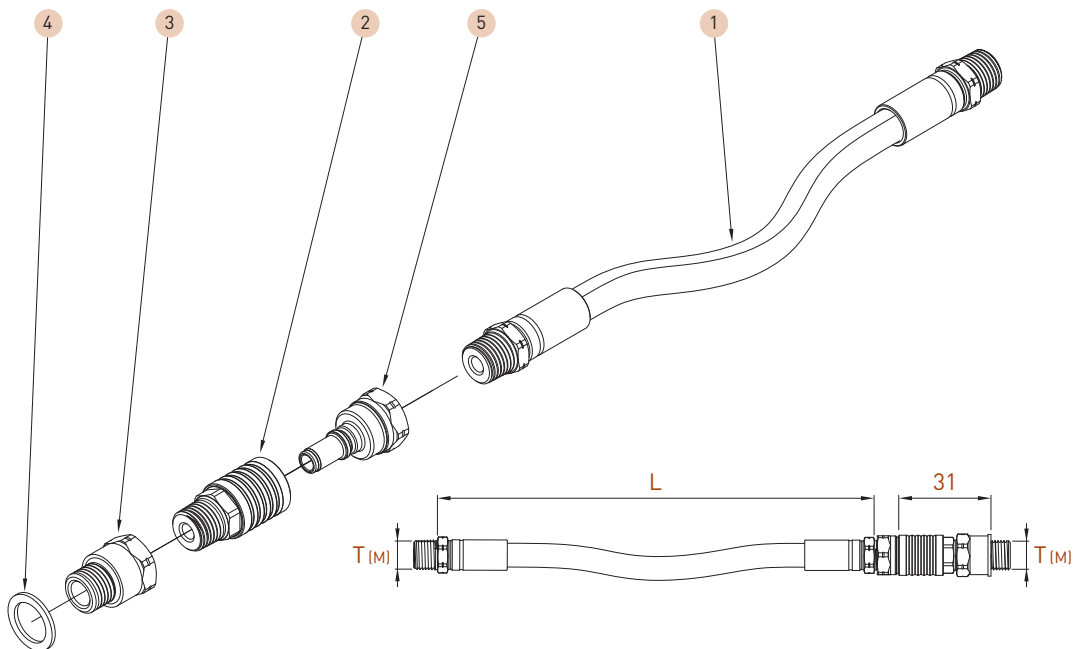

Ref	Qty	Kit composition
1	1	JTX-AC-BSPT1/8-L...
2	1	JS-BSPT1/8-D6
3	1	JRMF-BSP1/8-BSP1/8-L10.5
4	1	JO-BSP1/8
5	1	JVF-BSP1/8-D6

D	T (M)	L	Art. N°
6	BSP1/8	102	<b>JKIT-BSP1/8-D6-102-QF</b>
		203	<b>JKIT-BSP1/8-D6-203-QF</b>
		305	<b>JKIT-BSP1/8-D6-305-QF</b>
		406	<b>JKIT-BSP1/8-D6-406-QF</b>

Compatibilité  
Kompatibilität  
Compatibility



Porte-outil/Halter/Holder BSP1/8

Options



Art. N°

**JK-BSP1/8-1515-4T**

voir page 16.34  
siehe Seite 16.34  
see page 16.34



Art. N°

**C-SW11-E3.7**

voir page 16.45  
siehe Seite 16.45  
see page 16.45

**Kit de connexion**

**Verbindungskit Quick / Quick**

**Connection kit**

**BSP1/8**

**JKIT-BSP1/8-D6-...-QQ**

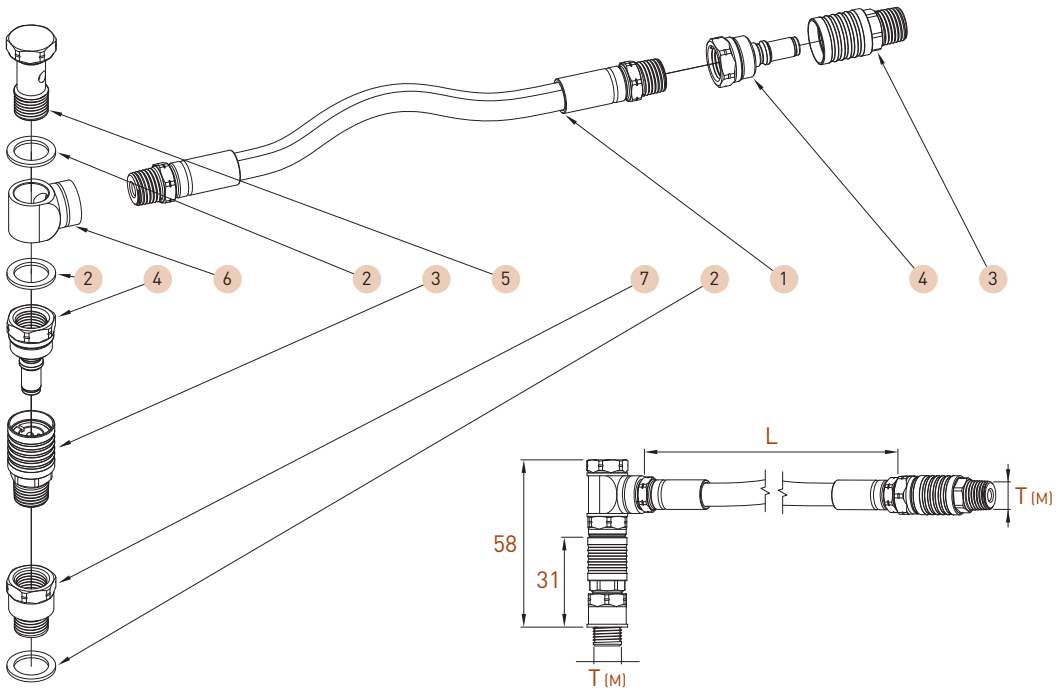

Ref	Qty	Kit composition
1	1	JTX-AC-BSPT1/8-L...
2	3	JO-BSP1/8
3	2	JS-BSPT1/8-D6
4	2	JVF-BSP1/8-D6
5	1	JEB-BSP1/8-L26
6	1	JCBF-Ø10-BSP1/8
7	1	JRMF-BSP1/8-BSP1/8-L10.5

D	T (M)	L	Art. N°
6	BSP1/8	102	<b>JKIT-BSP1/8-D6-102-QQ</b>
		203	<b>JKIT-BSP1/8-D6-203-QQ</b>
		305	<b>JKIT-BSP1/8-D6-305-QQ</b>
		406	<b>JKIT-BSP1/8-D6-406-QQ</b>

Compatibilité  
Kompatibilität  
Compatibility

**Porte-outil/Halter/Holder BSP1/8**

Options

Art. N°	Art. N°
<b>JK-BSP1/8-1515-4T</b>	<b>C-SW11-E3.7</b>
voir page 16.34 siehe Seite 16.34 see page 16.34	voir page 16.45 siehe Seite 16.45 see page 16.45



Qty	Kit composition	Art. N°
2	C-SW8-E2.5	<b>JSTART-D4</b>
4	JO-M6	
2	JO-M5	
2	JK-M6-1010-4T	
10	JS-M6-D4	
2	JTX-AC-M6-102	
2	JTX-AC-M6-203	
2	JTX-AC-M6-305	
2	JTX-AC-M6-406	
10	JVF-M6-D4	
2	JVB-D4	
2	JWF-M6-D4	
2	JRMF-M6-M6-L7.5	
2	JRMF-M6-M6-L12.5	
2	JRMF-M6-M6-L17.5	
10	JRMF-M5-M6-L7.5	
2	JRFF-M6-L9.0	
5	JCBF-Ø6-M6	
2	JABF-Ø6-M6-45°	
5	JEB-M6-L19	
2	JEB-M6-L30-DUO	
1	JT-CU-M6-102	
1	JT-CU-M6-203	

Starter Kit

M8X1 (+ BSP1/8)

JSTART-D6



Qty	Kit composition	Art. N°
2	C-SW11-E3.7	<b>JSTART-D6</b>
4	JO-M8X1	
2	JK-M8X1-1515-4T	
10	JS-M8X1-D6	
2	JTX-AC-M8X1-102	
2	JTX-AC-M8X1-203	
2	JTX-AC-M8X1-305	
2	JTX-AC-M8X1-406	
10	JVF-M8X1-D6	
2	JVB-D6	
2	JWF-M8X1-D6	
2	JRMF-M8X1-M8X1-L9.5	
2	JRMF-M8X1-M8X1-L14.5	
2	JRMF-M8X1-M8X1-L19.5	
10	JRMF-BSPT1/8-M8X1-L9.0	
2	JRFF-M8X1-L12.0	
5	JCBF-Ø8-M8X1	
2	JABF-Ø8-M8X1-45°	
5	JEB-M8X1-L24	
2	JEB-M8X1-L38-DUO	
1	JT-CU-M8X1-102	
1	JT-CU-M8X1-203	

# JET-LINE

Raccord rapide  
Schnellkupplungen  
Quick connector

JS

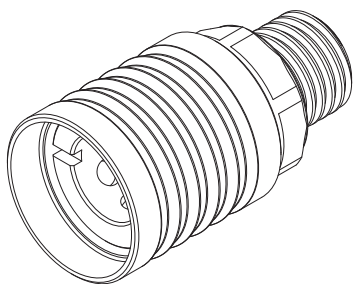
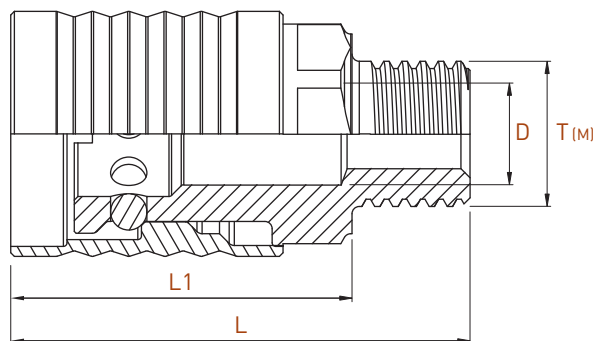
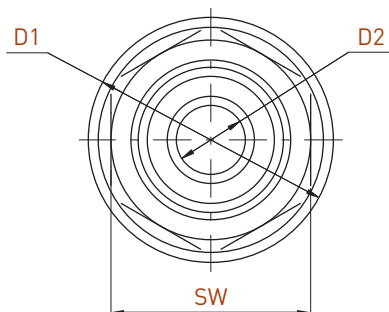

T (M)	L	L1	SW	D	D1	D2	Art. N°
M5	18	14	8	4	9.8	2.3	JS-M5-D4
M6	18	14	8	4	9.8	2.3	JS-M6-D4
M8X1KEG	20	14	8	4	9.8	2.3	JS-M8X1KEG-D4
M8X1	25	19	11	6	13.5	3.8	JS-M8X1-D6
BSPT1/8	29.3	19	11	6	13.5	3.8	JS-BSPT1/8-D6

Pression max Max. Druck max. pressure	KEG =	BSPT =
= 220 Bar (3.190 PSI)	filetage conique konisches Gewinde conical thread	filetage conique konisches Gewinde conical thread



Joint d'étanchéité en cuivre

Kupferdichtungsringe

Copper sealing gasket

JO

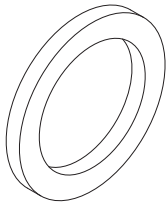
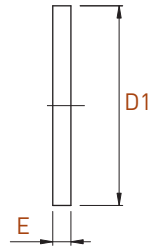
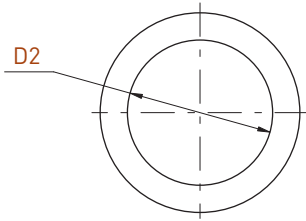

D1	D2	E	Art. N°
9	5	1	JO-M5*
9	6	1	JO-M6*
11	8	1	JO-M8X1*
14	10	1	JO-BSP1/8*

\* vendu par 10 pces  
 10-facherweise verkauft  
 sold by 10 pcs

# JET-LINE

Tube de distribution flexible en acier inoxydable tressé

Rostfreier Stahlflex-Schlauch

Flexible distribution tube of stainless steel braiding

## JTX-AC

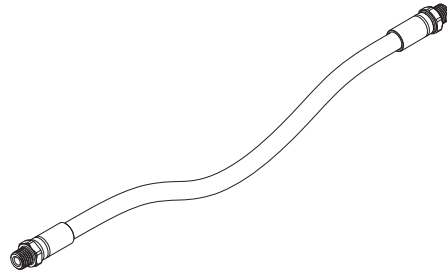
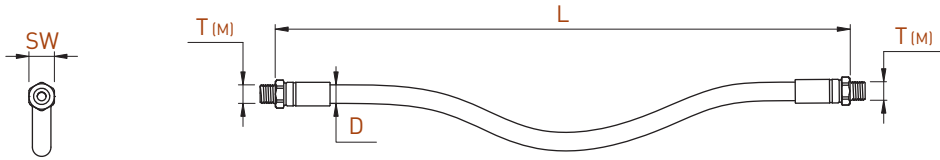

T (M)	L*	SW	D	Art. N°
M6	102	8	Ø6.5	JTX-AC-M6-102
	203	8	Ø6.5	JTX-AC-M6-203
	305	8	Ø6.5	JTX-AC-M6-305
	406	8	Ø6.5	JTX-AC-M6-406
M8X1	102	11	Ø8	JTX-AC-M8X1-102
	203	11	Ø8	JTX-AC-M8X1-203
	305	11	Ø8	JTX-AC-M8X1-305
	406	11	Ø8	JTX-AC-M8X1-406
BSPT1/8	102	11	Ø8	JTX-AC-BSPT1/8-102
	203	11	Ø8	JTX-AC-BSPT1/8-203
	305	11	Ø8	JTX-AC-BSPT1/8-305
	406	11	Ø8	JTX-AC-BSPT1/8-406

\* Longueur spécifique possible sur demande  
 Spezifische Länge auf Anfrage möglich  
 Specific length possible on request

Pression max Max. Druck max. pressure			Pression (bar)	Ø 6.5 (l/min)	Ø 8 (l/min)
	KEG =	BSPT =			
= 220 Bar (3.190 PSI)	filetage conique	filetage conique	2	3.5	9.5
	konisches Gewinde	konisches Gewinde	8	7.0	19.0
	conical thread	conical thread	15	9.6	26.0
			20	11.0	30.1
			30	13.5	36.9
			50	17.5	47.6
			80	22.1	60.3
			100	24.7	67.4
		150	30.2	82.5	

**Tube de distribution en cuivre**

**Kupferrohr**

**Copper distribution tube**

**JT-CU**

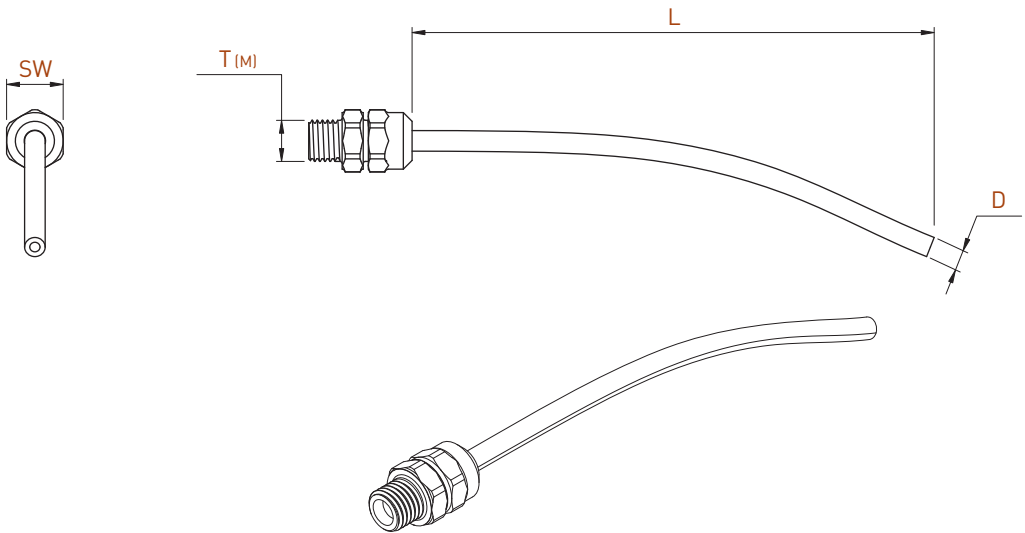

T (M)	L*	SW	D	Art. N°
M6	102	8	Ø3	JT-CU-M6-102
	203	8	Ø3	JT-CU-M6-203
	305	8	Ø3	JT-CU-M6-305
	406	8	Ø3	JT-CU-M6-406
M8X1	102	11	Ø4	JT-CU-M8X1-102
	203	11	Ø4	JT-CU-M8X1-203
	305	11	Ø4	JT-CU-M8X1-305
	406	11	Ø4	JT-CU-M8X1-406

\* Longueur spécifique possible sur demande  
 Spezifische Länge auf Anfrage möglich  
 Specific length possible on request

Pression max  
 Max. Druck  
 max. pressure

= 220 Bar  
 (3.190 PSI)

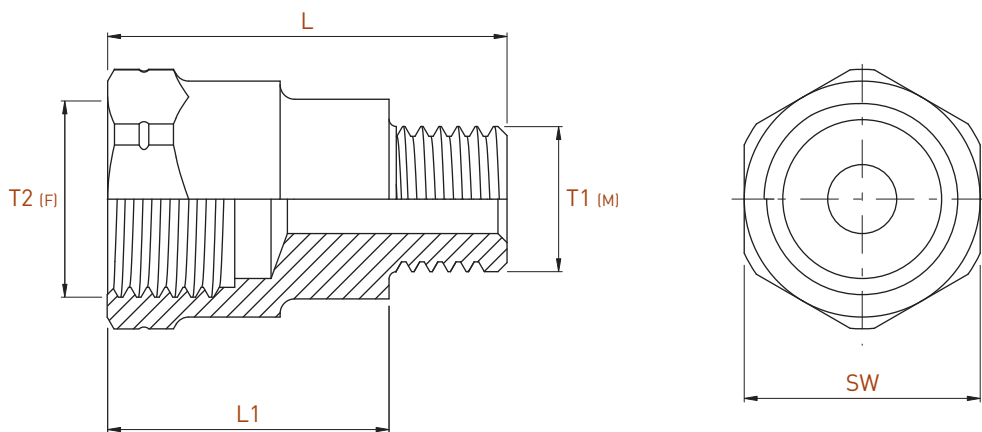

T1 (M)	T2 (F)	L1	L	SW	Art. N°
M5	M5	6.5	11	8	JRMF-M5-M5-L6.5
		11.5	16	8	JRMF-M5-M5-L11.5
		16.5	21	8	JRMF-M5-M5-L16.5
	M6	7.5	12	8	JRMF-M5-M6-L7.5
		M8X1	9.5	14	11
M6	M6	7.5	12.5	8	JRMF-M6-M6-L7.5
		12.5	17.5	8	JRMF-M6-M6-L12.5
		17.5	22.5	8	JRMF-M6-M6-L17.5
	M8X1	9.5	14.5	11	JRMF-M6-M8X1-L9.5
	M8X1KEG	M6	6	12	8
M8X1		9.5	16.5	11	JRMF-M8X1KEG-M8X1-L9.5
M8X1		M5	5.5	12	11
	M6	7	13.5	11	JRMF-M8X1-M6-L7.0
	M8X1	9.5	16	11	JRMF-M8X1-M8X1-L9.5
		14.5	21	11	JRMF-M8X1-M8X1-L14.5
		19.5	26	11	JRMF-M8X1-M8X1-L19.5
		10.5	17	13	JRMF-M8X1-BSP1/8-L10.5
	BSP1/8	15.5	22	13	JRMF-M8X1-BSP1/8-L15.5
		20.5	27	13	JRMF-M8X1-BSP1/8-L20.5
NPT1/8	11	17.5	13	JRMF-M8X1-NPT1/8-L11 <b>new</b>	
M8X1.25	M8X1	9.5	16	11	JRMF-M8X1.25-M8X1-L9.5 <b>new</b>
BSPT1/8	M5	3.5	14.6	11	JRMF-BSPT1/8-M5-L3.5
	M6	3.5	14.6	11	JRMF-BSPT1/8-M6-L3.5
	M8X1	9	20.3	11	JRMF-BSPT1/8-M8X1-L9.0
BSP1/8	BSP1/8	10.5	18	13	JRMF-BSP1/8-BSP1/8-L10.5
		15.5	23	13	JRMF-BSP1/8-BSP1/8-L15.5
		20.5	28	13	JRMF-BSP1/8-BSP1/8-L20.5
NPT1/8	M8X1	7	17	13	JRMF-NPT1/8-M8X1-L7.0 <b>new</b>
	BSP1/8	9	20.3	13	JRMF-NPT1/8-BSP1/8-L9.0 <b>new</b>
NPT1/16	M6	6	15	11	JRMF-NPT1/16-M6-L6.0 <b>new</b>
	M8X1	9	18	13	JRMF-NPT1/16-M8X1-L9.0 <b>new</b>
SAE7/16-20	M6	4.5	12	13	JRMF-SAE7/16-20-M6-L4.5 <b>new</b>
	M8X1	7	14.5	13	JRMF-SAE7/16-20-M8X1-L7 <b>new</b>

**Connecteurs mâle/femelle avec cône 60°**

**Innen und Außengewinde mit 60°-Kegel**

**Male/female connectors with cone 60°**

**JRMF-A60°**

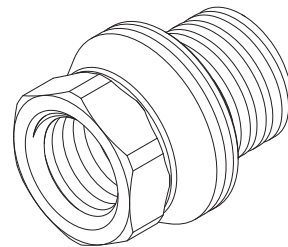
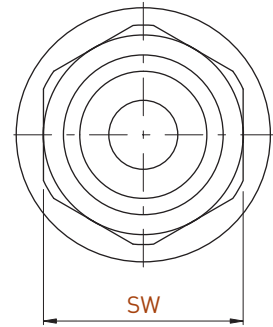
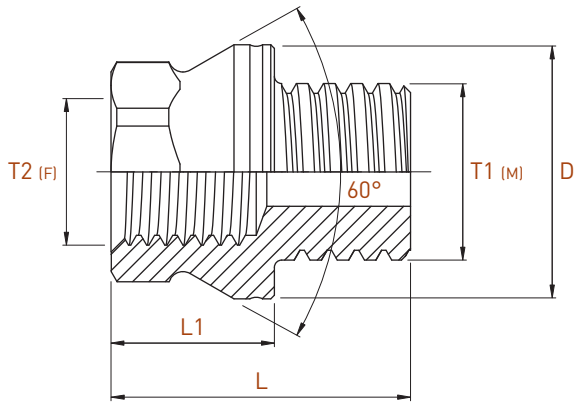

T1 (M)	T2 (F)	L1	L	D	SW	Art. N°
BSP1/8	M8X1	9	16.5	14	11	<b>JRMF-BSP1/8-M8X1-A60°-L9.0</b>

# JET-LINE

Connecteurs femelle/femelle  
Gewindeadapter Innengewinde  
Female connectors

JRFF

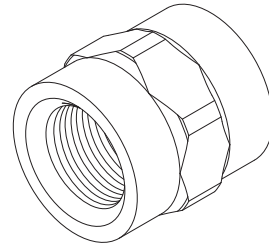
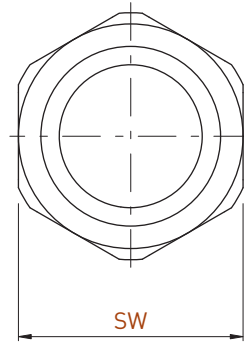
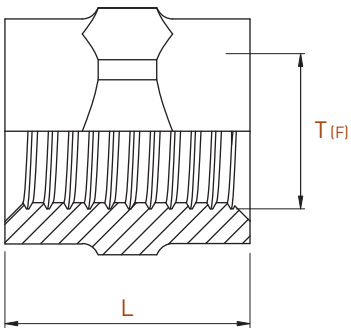

T (F)	L	SW	Art. N°
M6	9	8	JRFF-M6-L9.0
M8X1	12	11	JRFF-M8X1-L12.0

Connecteurs mâle/mâle

Gewintheadapter Außengewinde

Male connectors

JRMM

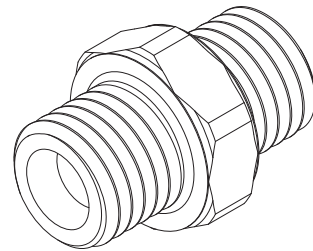
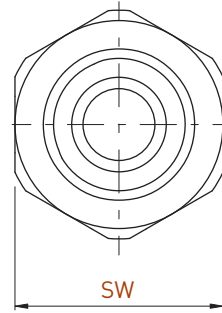
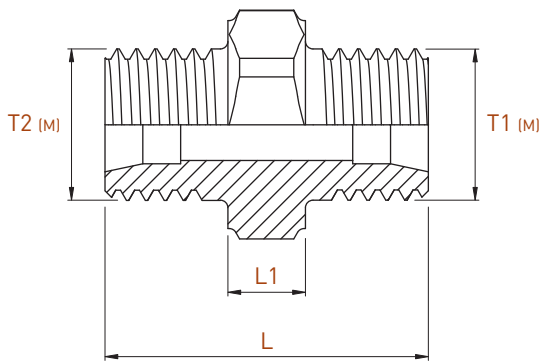

T1 (M)	T2 (M)	L1	L	SW	Art. N°
M6	M6	3	13	8	JRMM-M6-M6-L3.0
M8X1	M8X1	4	17	11	JRMM-M8X1-M8X1-L4.0
M10	M8X1	3.5	17.5	11	JRMM-M10-M8X1-3.5 <span style="color: red; font-weight: bold;">new</span>

# JET-LINE

Écrous d'étanchéité

Dichtungsmutter

Sealing nuts

JN

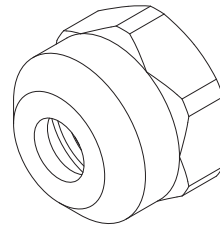
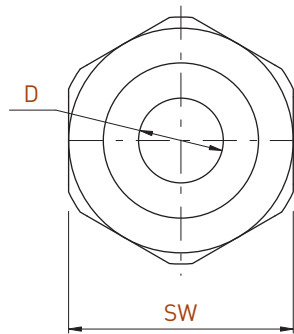
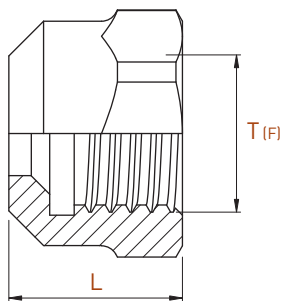

T (F)	L	D	SW	Art. N°
M6	6.5	3	8	JN-M6-D3
M8X1	8.5	4	11	JN-M8X1-D4
M10	11.5	6	12	JN-M10-D6 <span style="color: red; font-weight: bold;">new</span>



**Bague d'étanchéité**

**Dichtungsring**

**Sealing ring**

**JNG**

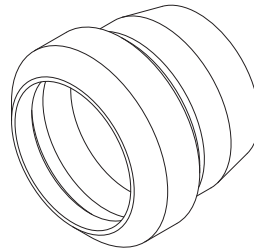
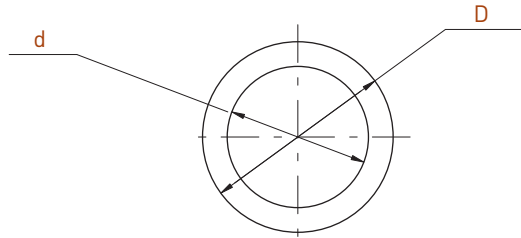
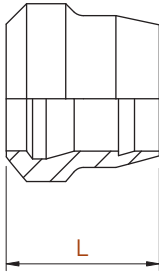

d	D	L	Art. N°
3	4	3.3	JNG-D3
4	5.5	4.5	JNG-D4
6	8.5	7	JNG-D6 <span style="color: red; font-weight: bold; font-size: small;">new</span>

# JET-LINE

Banjos courts femelle

Kurzer Innengewintheadapter

Short female banjos

JCBF

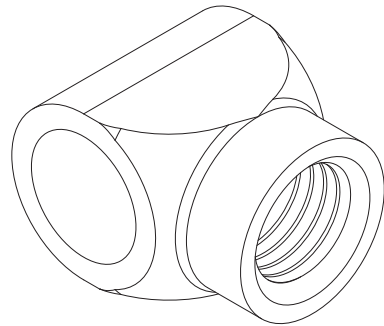
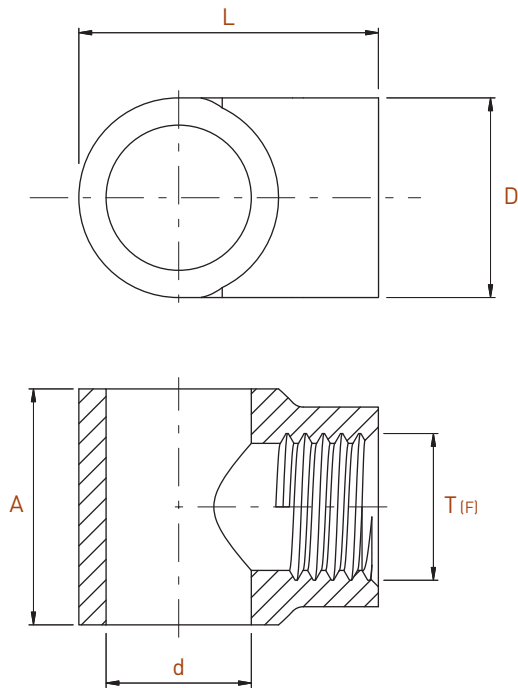

T (F)	A	L	d	D	Art. N°
M6	10	12.5	6	9	JCBF-06-M6
M8X1	13	16.5	8	11	JCBF-08-M8X1
M8X1	13	18.5	10	11	JCBF-010-M8X1
BSP1/8	13	19.5	10	13	JCBF-010-BSP1/8

**Banjos courts mâle**

**Kurzer Aussengewindeadapter**

**Short male banjos**

**JCBM**

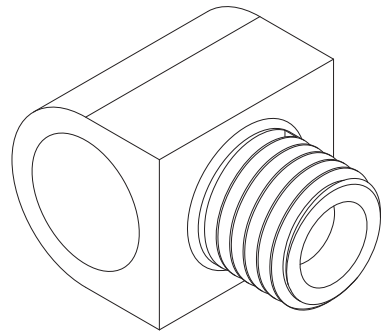
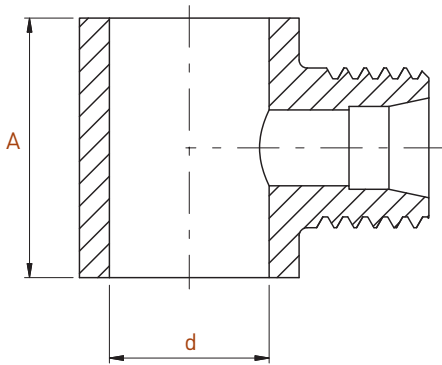
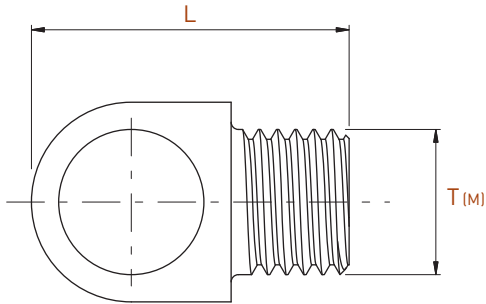

T (M)	A	L	d	Art. N°
M6	10	14	6	JCBM-Ø6-M6
M8X1	13	17.5	8	JCBM-Ø8-M8X1
	13	19.5	10	JCBM-Ø10-M8X1

# JET-LINE

**Banjos longs droits femelle**  
**Langer Innengewintheadapter**  
**Long straight female banjos**

**JABF**

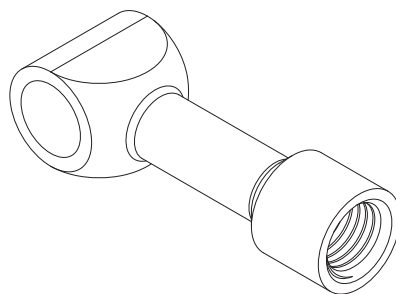
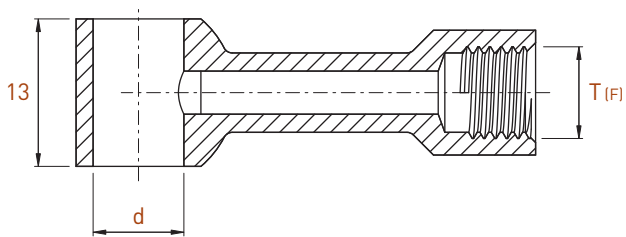
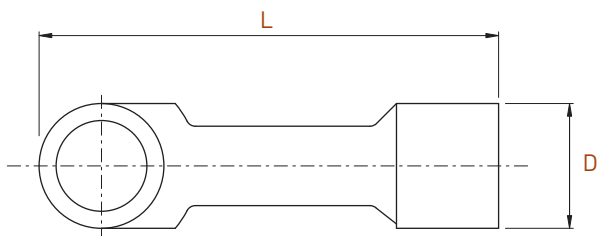

T (F)	A	L	d	D	Art. N°
M6	10	31.5	6	9	JABF-06-M6
M8X1	13	40.5	8	11	JABF-08-M8X1
M8X1	13	42.5	10	11	JABF-010-M8X1
BSP1/8	13	42.5	10	13	JABF-010-BSP1/8

- Banjos longs coudés femelle**
- Adapter lang 45° Innengewinde**
- Long curved female banjos**

**JABF-45°**

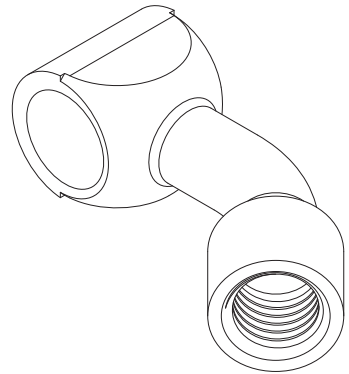
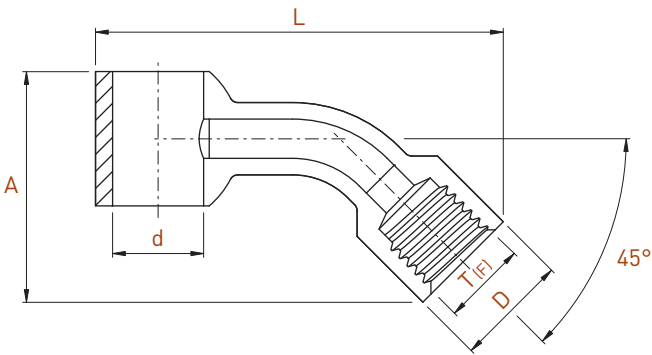
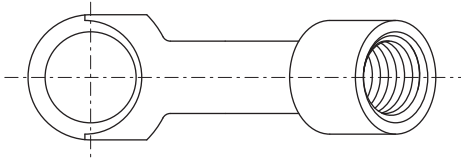

T (F)	A	L	d	D	Art. N°
M6	10	33	6	9	<b>JABF-Ø6-M6-45°</b>
M8X1	11.8	40	8	11	<b>JABF-Ø8-M8X1-45°</b>
	13	40.5	10	11	<b>JABF-Ø10-M8X1-45°</b>

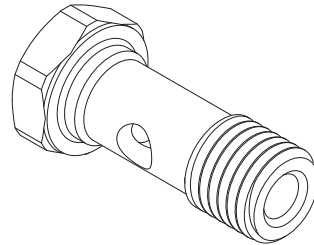
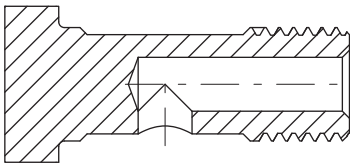
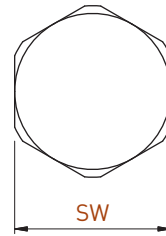
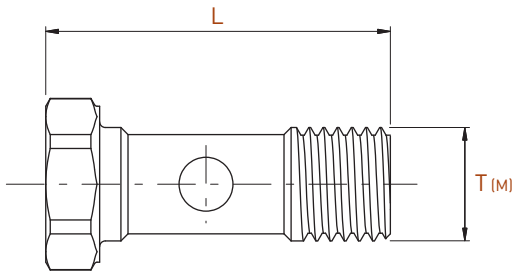

T (M)	L	SW	Art. N°
M5	18.3	8	<b>JEB-M5-L18</b>
M6	18.8	8	<b>JEB-M6-L19</b>
M8X1	24.3	11	<b>JEB-M8X1-L24</b>
BSP1/8	26	13	<b>JEB-BSP1/8-L26</b>

**Vis banjo double**

**Hohlschrauben doppelt**

**Double banjo screws**

**JEB-DUO**

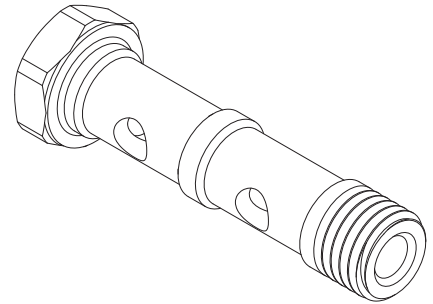
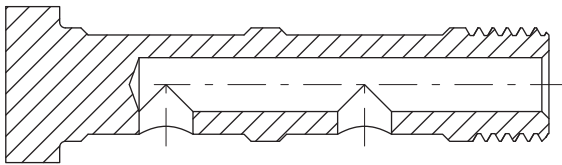
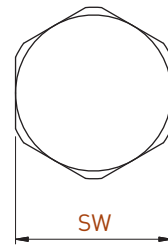
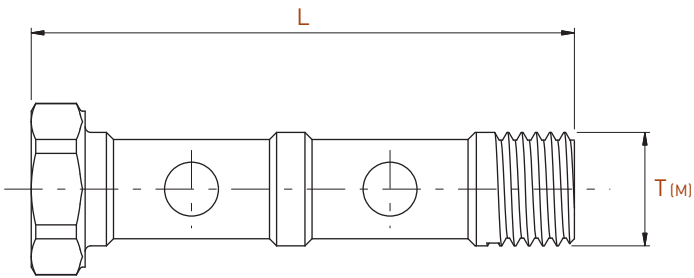

T (M)	L	SW	Art. N°
M6	29.8	8	<b>JEB-M6-L30-DUO</b>
M8X1	38.3	11	<b>JEB-M8X1-L38-DUO</b>
BSP1/8	40	13	<b>JEB-BSP1/8-L40-DUO</b>

# JET-LINE

Fiches de verrouillage

Verschlussstecker

Sealing connecting plugs

JVB

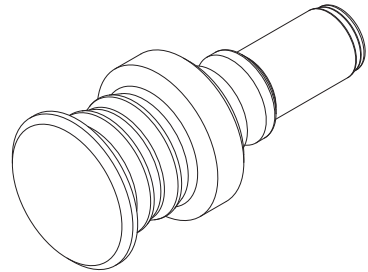
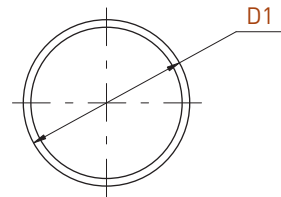
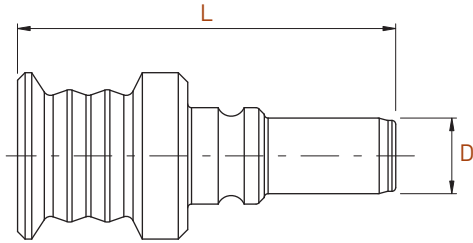

D	D1	L	Art. N°
4	8.8	20	JVB-D4
6	12	27	JVB-D6



Fiches de connexion

Innengewindestecker

Connecting plugs

**JVF**

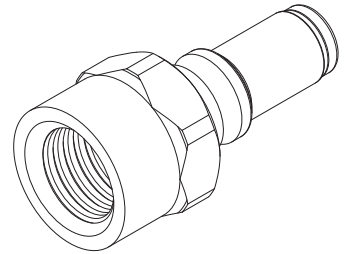
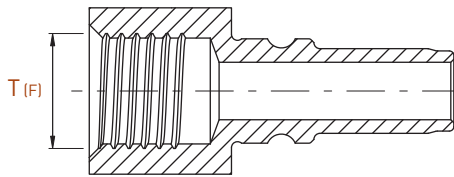
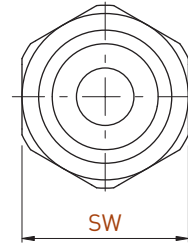
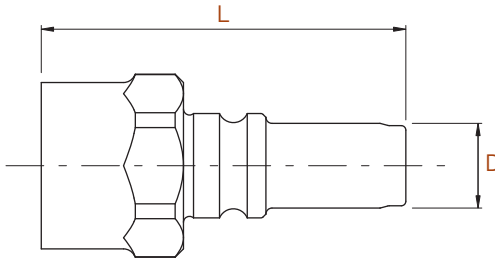

D	T (F)	L	SW	Art. N°
4	M6	18.3	8	<b>JVF-M6-D4</b>
6	M8X1	24	11	<b>JVF-M8X1-D6</b>
6	BSP1/8	25.5	11	<b>JVF-BSP1/8-D6</b>

# JET-LINE

- Fiches de connexion fixes femelle
- Innengewindestecker mit Verdrehsicherung
- Female positioning connection plugs

JWF

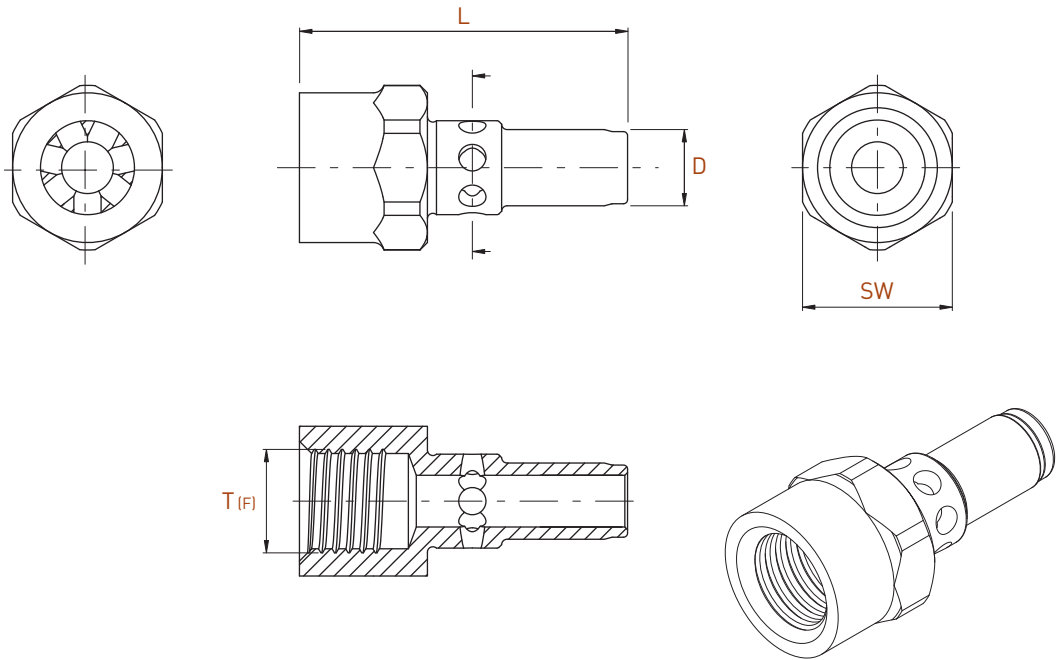

D	T (F)	L	SW	Art. N°
4	M6	18.3	8	JWF-M6-D4
6	M8X1	24	11	JWF-M8X1-D6

**Fiches de connexion fixes mâle**

**Aussengewindestecker mit Verdrehsicherung**

**Male positioning connection plugs**

**JWM**

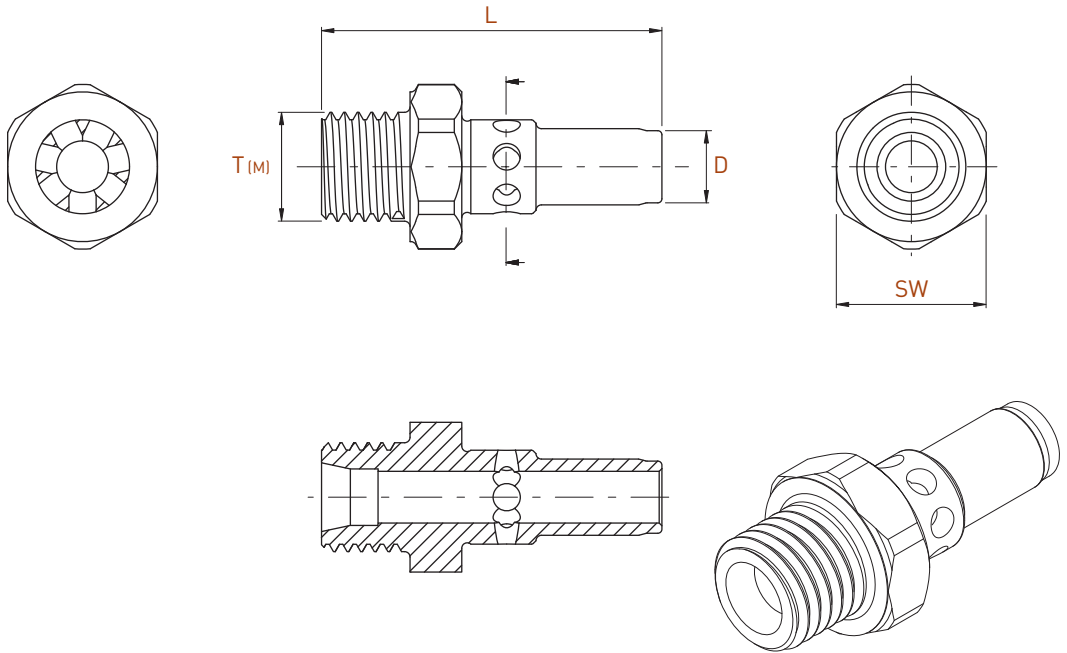

D	T (M)	L	SW	Art. N°
4	M6	18.3	8	<b>JWM-M6-D4</b>
6	M8X1	25	11	<b>JWM-M8X1-D6</b>

# JET-LINE

Blocs de distribution

Kühlmittelverteiler

Distribution blocks

JK

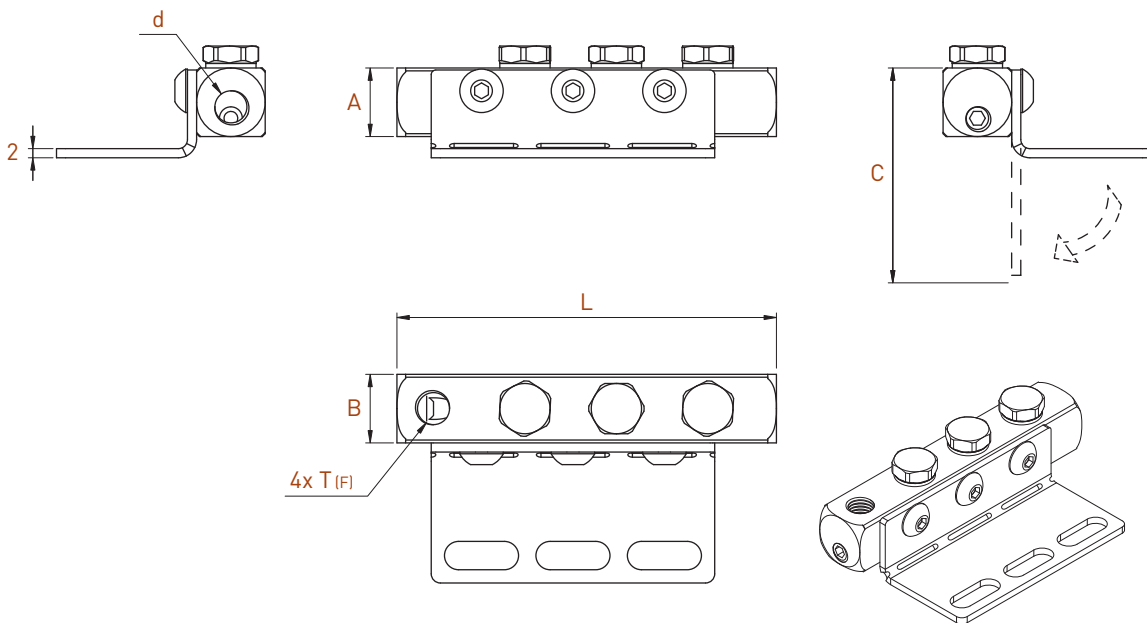

T (F)	A	B	C	d	L	Art. N°
M5	10	10	37	M5	62	JK-M5-1010-4T
M6	10	10	37	M6	62	JK-M6-1010-4T
M8X1	15	15	47	M8X1	83	JK-M8X1-1515-4T
BSP1/8	15	15	47	BSP1/8	83	JK-BSP1/8-1515-4T

Qty	Livré avec	Mitgeliefert	Supplied with
1	Plaque de serrage pliable	Faltbare Klemmplatte	Foldable clamping plate
3	Vis bombée	Linsenkopfschraube	Domed clamping Screw
3	Vis sans tête bouchon	Verschlußstopfen	Sealing screw
3	Joint d'étanchéité en cuivre	Kupferdichtungsringe	Copper sealing basket
1	Vis sans tête bouchon	Madenschraube	Grub screw

**Bouchons d'étanchéité**

**Verschlußstopfen**

**Sealing plugs**

**JBB**

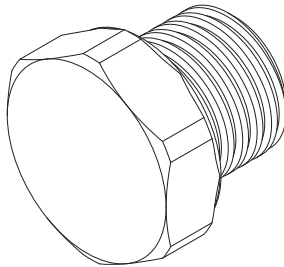
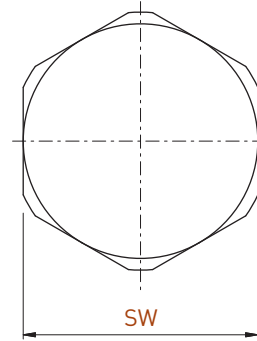
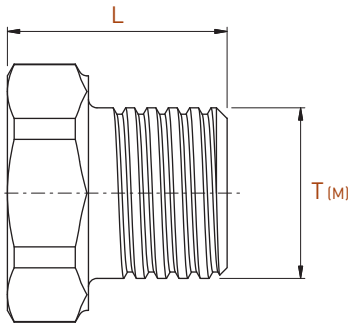

SW	T (M)	L	Art. N°
8	M5	7.3	<b>JBB-M5-L7.0</b>
8	M6	7.8	<b>JBB-M6-L8.0</b>
11	M8X1	10.3	<b>JBB-M8X1-L10.0</b>
11	BSP1/8	10.3	<b>JBB-BSP1/8-L10.0</b>

# JET-LINE

Kit articulé avec buse d'arrosage

Gelenkkit mit Kühlungsdüse

Articulated kit with coolant nozzle

## JKIT-AR3

**new**

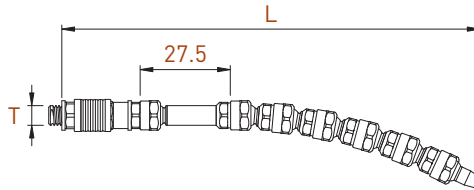
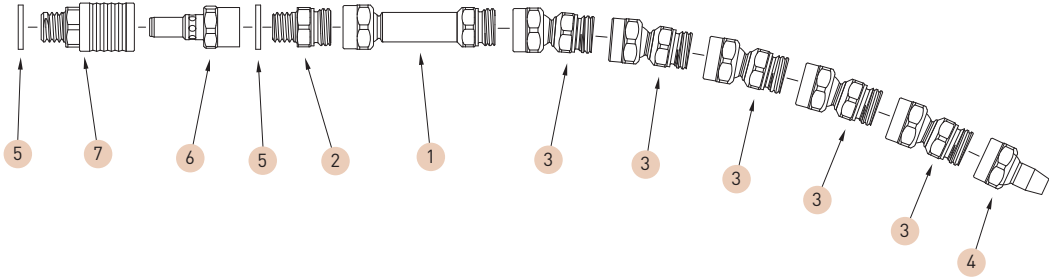

Ref	Qty	Kit composition
1	1	JAR3-L27.5
2	1	JRMM-AR3-M6-L3.0
3	5	JAR3-L12.5
4	1	JJ-AR3-D3-L9
5	2	JO-M6
6	1	JWF-M6-D4
7	1	JS-M6-D4

T (M)	L	Art. N°
M6	130	<b>JKIT-AR3-M6-D3-130</b>

Pression max	Couple de serrage Anzugsmoment Torque setting
<b>150 bar (2.175psi)</b>	<b>1.8 Nm</b>

Option recommandée Empfohlene Option Recommended option	Page Seite Page
<b>C-AR3</b> 	<b>16.45</b>



# JET-LINE

Kit tube en cuivre avec buse d'arrosage

Kit Kupferrohr mit Kühlungsdüse

Kit copper tube with coolant nozzle

## JKIT-CU

**new**

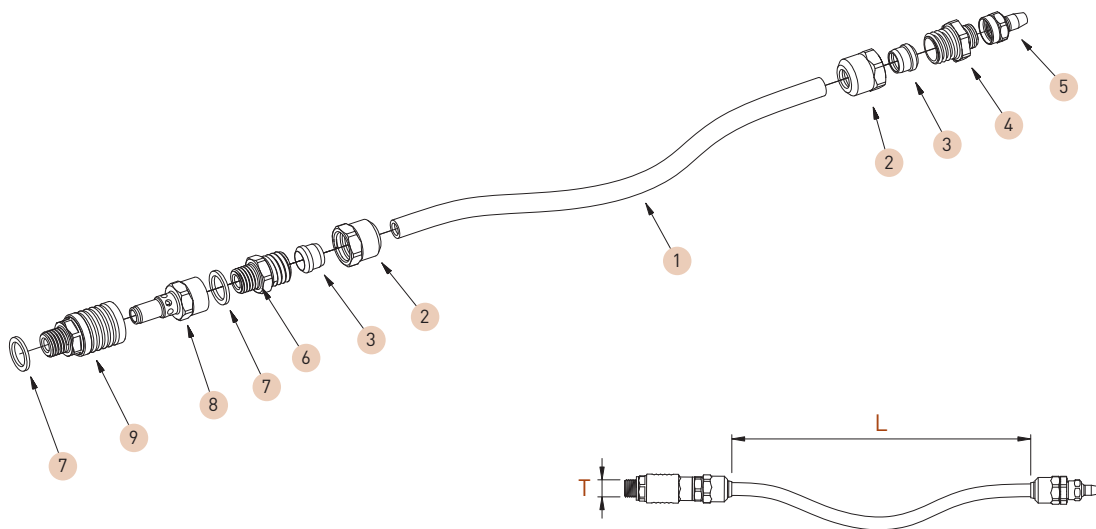

Ref	Qty	Kit composition
1	1	JT-CU
2	2	JN-M10-D6
3	2	JNG-D6
4	1	JRMM-AR3-M10-L3.0
5	1	JJ-AR3-D3-L9
6	1	JRMM-M10-M8X1-L3.5
7	2	JO-M8X1-D6
8	1	JWF-M8X1-D6
9	1	JS-M8X1-D6

T (M)	L	Art. N°
M8X1	305	<b>JKIT-CU-AR3-D3-M8X1-305</b>



Système articulé  
 Gelenksystem  
 Articulated system

JAR

new

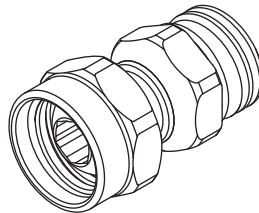
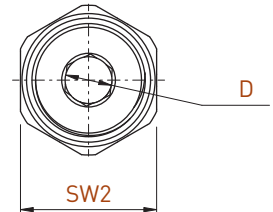
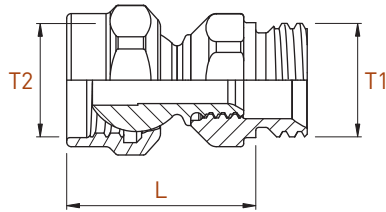
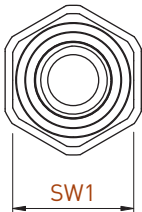

T1 (M)	T2 (F)	L	D	SW1	SW2	Art. N°
M7.5	M7.5	12.5	3	8	9	JAR3-L12.5
		27.5	3			JAR3-L27.5
		42.5	3			JAR3-L42.5
M13	M13	20.5	6	13	15	JAR6-L20.5
		45.5	6			JAR6-L45.5
		70.5	6			JAR6-L70.5

# JET-LINE

Connecteurs mâle/mâle  
Anschlüsse Aussengewinde  
Male connectors

JRMM-AR

new

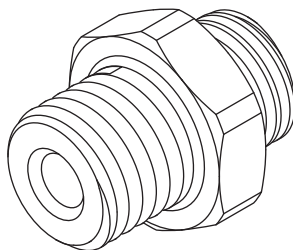
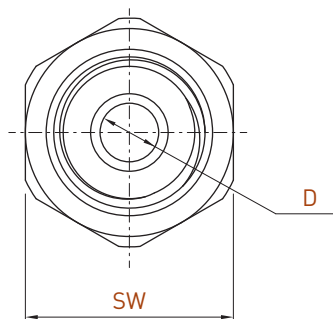
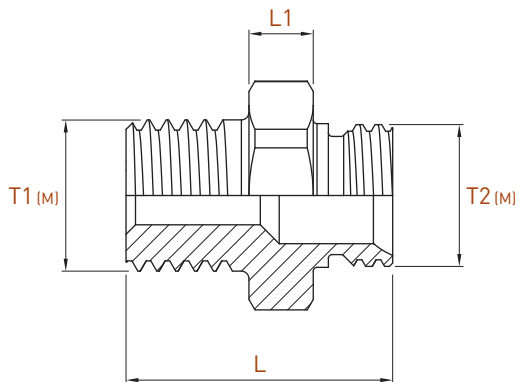

T1 (M)	T2 (M)	L	L1	D	SW	Art. N°
M6	M7.5	12	3	3	8	JRMM-AR3-M6-L3.0
M8X1	M7.5	14	3.5	3	11	JRMM-AR3-M8X1-L3.5
M10	M7.5	15	3	3	11	JRMM-AR3-M10-L3.0
M8X1	M13	4	17	6	13	JRMM-AR6-M8X1-L4.0
M10X1	M13	4	18	6	13	JRMM-AR6-M10X1-L4.0
BSP 1/8"	M13	4	18	6	13	JRMM-AR6-BSP1/8-L4.0

Buses

Düse

Nozzle

JJ-AR

new

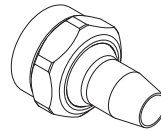
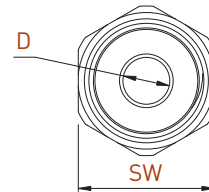
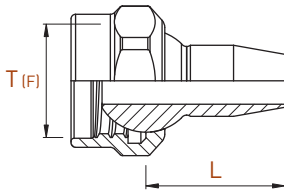

T (F)	L	D	SW	Art. N°
M7.5	9	3	9	JJ-AR3-D3-L9
M13	16	6	15	JJ-AR6-D6-L16

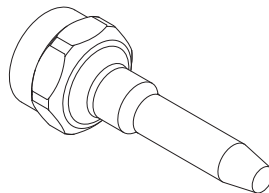
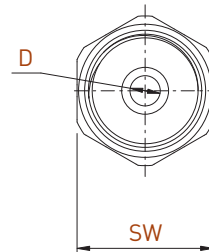
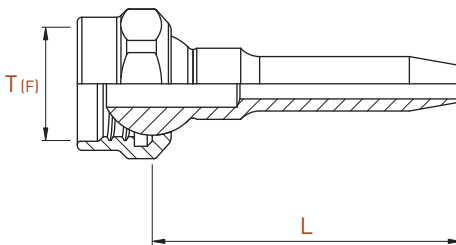

T (F)	L	D	SW	Art. N°
M7.5	20	2	9	JJ-AR3-D2-L20
M13	35	3	15	JJ-AR6-D3-L35

# JET-LINE

Buses

Düse

Nozzle

JJ-AR

**new**

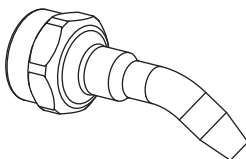
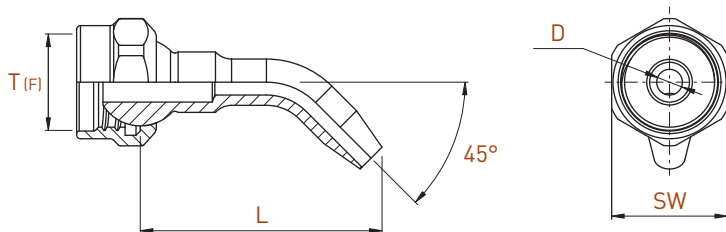

T (F)	L	D	SW	Art. N°
M7.5	19	2	9	JJ-AR3-D2-L19-45°
M13	23,5	6	15	JJ-AR6-D6-L23.5-45°

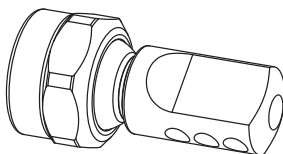
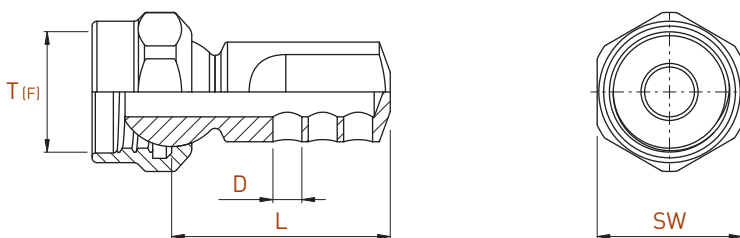

T (F)	L	D	SW	Art. N°
M7.5	15	1.8	9	JJ-AR3-3XD1.8-L13.5
M13	24	3.4	15	JJ-AR6-3XD3.4-L24

Appareil de cintrage

Biegegerät

Bending tool

JTB

new

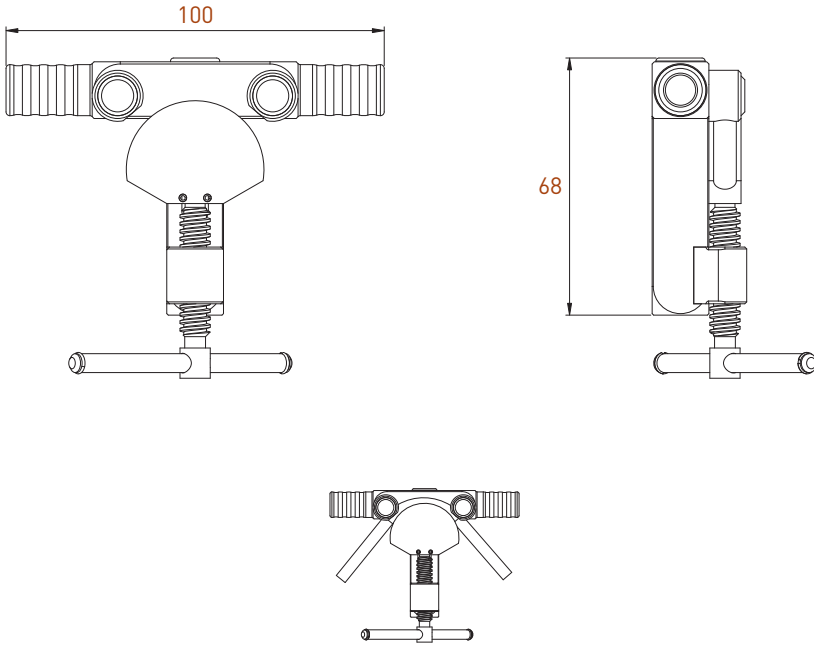

Art. N°

JTB-D6



**Clés de serrage**  
**Gabelschlüssel**  
**Clamping keys**

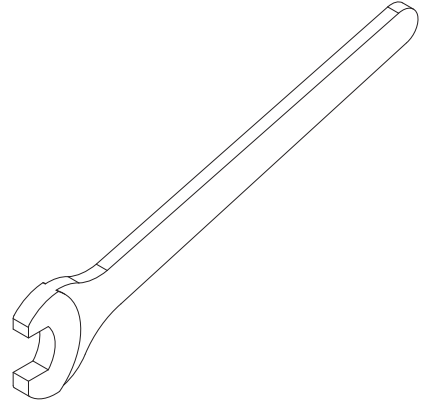
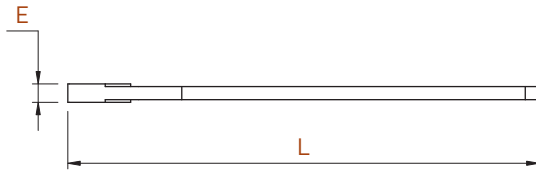
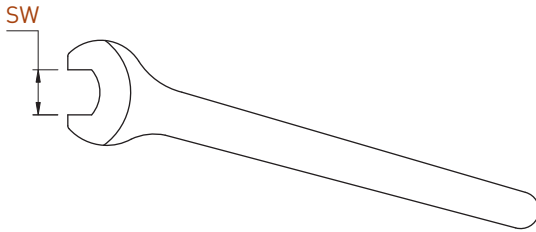

SW	E	L	Art. N°
8	2.5	90	C-SW8-E2.5
11	3.7	110	C-SW11-E3.7
13	5.8	130	C-SW13-E5.8
8	2.5	55	C-AR3
9	3		
13	3	65	C-AR6
15	4		

**new**

**new**

# INDEX

Répertoire des articles

Artikelverzeichnis

Index of items

	Art. N°	Page
<b>10</b>	1010	13.111
<b>11</b>	1101	15.04
	1102	15.06
	1103	15.08
	1104	15.10
	1106	15.12
	1107	13.19
<b>12</b>	1200	13.14
<b>14</b>	1400-J	13.02
	1401-K	13.03
	1402	13.18
	1420	13.04
	1460	13.05
<b>15</b>	1500	13.15
	1510	13.15
<b>16</b>	1600	13.16
	1610	13.17
	1680	14.108
<b>18</b>	1820	15.17
<b>19</b>	1901	13.97
<b>20</b>	2010	14.112
	2011	14.113
	2012	14.113
	2013	14.114
	2014	14.114
	2020	14.115
	2023	14.117
	2026	14.120
	2030	14.122
<b>22</b>	2200	13.14
<b>24</b>	2400-J	13.02
	2401-K	13.03
	2402	13.18
	2405	13.08
	2420	13.04
	2425	13.09
	2435	13.12
	2436	13.13
	2440	13.10
	2441	13.10
	2450	13.07
	2450-SP	13.06
	2460	13.07
	2470	13.06
<b>25</b>	250	4.04
	251	4.08
	251-E	4.17
	252	4.10
	2520	13.15
	253	4.12
	2530	13.15
	254	4.14
	256	4.16
<b>26</b>	260	4.04
	261	4.08
	261-E	4.17
	262	4.10
	2620	13.16
	263	4.12
	2630	13.17

	Art. N°	Page
	264	4.14
	266	4.16
	2680	14.107
	2690	14.110
<b>28</b>	2810	15.16
	2811	15.16
	2815	15.16
	2820	15.17
<b>31</b>	310	6.06
	3123	14.58
	317	6.08
	3170	14.07
	318	6.08
	319	6.09
<b>32</b>	320	6.06
	3230	14.63
	3231	14.66
	3238	14.89
	3239T	14.67
	327	6.08
	3270S	14.18
	3271	14.11
	3278	14.44
	3279T	14.21
	328	6.08
	329	6.09
	32xxMV	13.60
<b>33</b>	330	6.10
	3330	14.69
	3331	14.72
	3336-HA	14.73
	3337-HA	14.73
	3338	14.90
	3341	14.74
	3345-S	14.75
	3361	14.76
	337	6.12
	3370S	14.33
	3371	13.24
	3375	14.30
	3379T	14.36
	338	6.12
	3383	14.93
	339	6.13
<b>34</b>	340	6.10
	3430	14.78
	3431	14.79
	3439T	14.84
	3441	14.80
	3445-S	14.81
	3450	14.85
	347	6.12
	3471	14.39
	3472	14.42
	348	6.12
	349	6.13
<b>35</b>	3545	14.86
	35645	14.87
<b>36</b>	3611	14.95
<b>38</b>	3810	14.88



## Répertoire des articles

## Artikelverzeichnis

## Index of items

	Art. N°	Page
	383x	14.94
<b>39</b>	3901	14.97
	3911	14.96
<b>63</b>	630	3.06
	631-EP	3.30
	632	3.08
	633	3.12
	634	3.21
	635	3.24
	636	3.26
	637	3.28
<b>64</b>	640	3.06
	641-EP	3.30
	642	3.08
	643	3.12
	644	3.20
	645	3.24
	646	3.26
	647	3.28
<b>65</b>	650	3.31
	651	3.34
	651-EP	3.44
	660	3.31
	661	3.34
	661-EP	3.44
<b>70</b>	701S3371	14.91
	7050	1.143
	7051	1.144
	7051-E	1.148
	7060	1.143
	7061	1.144
	7061-E	1.148
<b>71</b>	710	1.10/2.06
	711	1.16
	711-EP	1.23
	711-ESF	2.09
	711SF	2.08
	712	1.17
	712SF	2.08
	713	1.18
	713SF	2.09
	714	1.21
	716	1.22
<b>72</b>	720	1.14
	721	1.16
	721-EP	1.23
	722	1.17
	723	1.18
	724	1.21
	726	1.22
<b>73</b>	730	1.26/2.10
	730R-DECO10	1.157
	730-DECO10	1.159
	730-NOVIBRA	1.30/2.11
	730RC	1.29/2.20
	730R-MULTISWISS	1.163
<b>72</b>	731	1.32
	731-E	1.67
	731-ESF	2.19
	731RSF	2.21

	Art. N°	Page
	732	1.46
	733	1.49
	734	1.56
	735	1.61
	736	1.63
	736SF	2.17
<b>74</b>	740	1.26/2.10
	740-DECO10	1.157
	740L-DECO10	1.159
	740-SF	2.11
	740Z	1.156
	741	1.32
	741-E	1.67
	741-ESF	2.19
	741SF	2.13
	742	1.46
	742SF	2.13
	743	1.49
	743SF	2.15
	744	1.56
	745	1.61
	746	1.63
	746SF	2.17
	748SF	2.18
	749SF	2.18
<b>75</b>	750	1.70
	750RAS	1.164
	750RC	1.72/2.20
	750R-DECO10	1.158
	750R-MULTISWISS	1.163
	751	1.78
	751-E	1.131
	751RDSF	2.21
	752	1.100
	753	1.106
	754	1.117
	756	1.125
	757	1.129
<b>76</b>	760	1.70
	760L-DECO10	1.160
	760Z	1.156
	761	1.78
	761-E	1.131
	762	1.100
	763	1.106
	764	1.117
	766	1.125
	767	1.129
<b>77</b>	770	1.133
	770R-DECO	1.161
	770-SN-SF	2.22
	771	1.136
	771-E	1.142
	771R	1.138
	771RVSF	2.24
<b>78</b>	780	1.133
	781	1.136
	781-E	1.142
<b>A</b>	A-SC...	7.17
	A-SD...	7.33

# INDEX

Répertoire des articles

Artikelverzeichnis

Index of items

	Art. N°	Page
	A-SV...	7.51
<b>B</b>	BA	10.20
	BAX	10.22
	BCX	10.24
	B-E	10.42
	BH-D	10.10
	BHKN	10.16
	BH-MASTER	10.44
	BHS	10.18
	BHS-D	10.12
	BHY-D	10.14
	BWD1	10.45
<b>C</b>	C45	10.26
	C45X	10.28
	CCGT	7.19
	CCMT	7.23
	CERMET CC...	7.25
	CERMET DC...	7.43
	CERMET VC...	7.60
	CUT-GN	9.21
	CUT-H	9.10
	CUT-HX	9.11
	CUT-HZ	9.12
	CUT-HZ-JET	9.13
	CUT-PN	9.16
	CUT-PNW	9.18
	CUT-PR	9.17
	CUT-PRW	9.19
	CUT-TN	9.20
	CUT-UL	9.15
	CUT-UN	9.14
	CUT-UR	9.15
<b>D</b>	DCGT	7.37
	DCMT	7.41
	DHP3336	14.77
	DHP3371	14.31
	DHP3436	14.83
	DHP3471	14.41
	DT	1.165
<b>E</b>	E100-P	14.100
	E300-P	14.101
	E300-R	14.102
	E900-P	14.103
	E-DHP	14.57
	E-SC...	7.18
	E-SD...	7.34
	ET UL	8.21
	ET-AN	8.26
	ET-AR	8.27
	ET-H	8.06
	ET-H-JET	8.07
	ET-HK	8.16
	ET-HK-RS	8.17
	ET-HM	8.14
	ET-HM-JET	8.15
	ET-HUK	8.18
	ET-JN	8.22
	ET-JR	8.23
	ET-TN	8.24
	ET-TR	8.25

	Art. N°	Page
	ET-UN	8.20
	ET-UR	8.21
<b>F</b>	FEG	10.41
	FIG	10.40
<b>G</b>	GTX	10.32
	GWS02R-HM	8.09
	GWS202L-HM	8.12
	GWS41L-HM	8.10
	GWS41R-HM	8.11
	GX	10.30
<b>H</b>	H-HM-JET	8.08
	HSK	1.155
	HSK-LW	11.21
<b>J</b>	JABF	16.26
	JABF-45°	16.28
	JAR	16.39
	JBB	16.35
	JCBF	16.24
	JCBM	16.25
	JEB-DUO	16.29
	JJ-AR	16.41
	JK	16.34
	JKIT	16.04
	JKIT-AR	16.36
	JKIT-CU	16.38
	JN	16.22
	JNG	16.23
	JO	16.15
	JRFF	16.20
	JRMF	16.18
	JRMM	16.21
	JRMM-AR	16.40
	JS	16.14
	JT-CU	16.17
	JTX-AC	16.16
	JVB	16.30
	JVF	16.31
	JWF	16.32
	JWM	16.33
<b>L</b>	LW-3_0-JET	11.09
	LW-7_0-JET	11.06
	LW-D	11.19
	LW-E	11.20
	LW-JET	11.05
	LW-SC_-JET	11.12
	LW-SD_-JET	11.14
	LW-SV_-JET	11.17
<b>M</b>	ML12A	12.64
	ML12-B074-1-6T	12.55
	ML12-B075-1-8T	12.56
	ML12-CITIZEN-C16	12.06
	ML12-CITIZEN-L12-1M7	12.07
	ML12-CITIZEN-L12-2M10	12.08
	ML12-CITIZEN-M16V/VIII	12.09
	ML12-CITIZEN-R04-QTF3101-3T	12.12
	ML12-CITIZEN-R04-QTF5008-4T	12.10
	ML12-CITIZEN-R04-QTF5108-4T	12.10
	ML12-CITIZEN-R07-QTF4008-5T	12.13
	ML12-CITIZEN-R07-QTF4108-6T	12.13
	ML12-CITIZEN-R07-QTF4208-3T	12.14

## Répertoire des articles

## Artikelverzeichnis

## Index of items

Art. N°	Page
ML12-CITIZEN-R07-QTF4608-4T	12.14
ML12-CT20-2020019-7T	12.43
ML12-D10-3T	12.21
ML12-DECO10-DUO	12.37
ML12-DECO10-JET	12.37
ML12-DT12-2020206-9T	12.42
ML12F	12.64
ML12-GT13-390223-7T	12.44
ML12-GT13-390224-5T	12.44
ML12-HANWHA-XD20M	12.18
ML12-PO34-1-5T	12.57
ML12-PO34-1-7T	12.58
ML12-PO34-2-10T	12.58
ML12-PO34-2-4T	12.57
ML12-STAR-SB-12RG	12.22
ML12-STAR-SR-10J	12.23
ML12-STAR-SW-12-R11-2T	12.24
ML12-STAR-SW-12-R11-8T	12.24
ML12-SWISS-NANO-2T	12.40
ML12-SWISS-NANO-3T	12.40
ML12-SWISS-NANO-6T	12.38
ML12-SWISS-NANO-7-4T	12.41
ML16A	12.64
ML16-CITIZEN-K16	12.15
ML16-CITIZEN-L20	12.16
ML16-CITIZEN-L20E	12.17
ML16-DECO13-DUO	12.50
ML16-DECO13-JET	12.50
ML16-DECO20-DUO	12.51
ML16-DECO20-JET	12.51
ML16-DT26-2020206-7T	12.54
ML16F	12.64
ML16-GT26-386209-6T	12.46
ML16-GT26-386210-5T	12.46
ML16-GT32-386209-5T	12.48
ML16-GT32-386210-4T	12.48
ML16-HANWHA-SL12/16	12.19
ML16-KMX26-DUO	12.20
ML16-KMX26-JET	12.20
ML16-S20-DUO	12.52
ML16-S20-JET	12.52
ML16-STAR-SA-16	12.25
ML16-STAR-SB-16	12.26
ML16-STAR-SB-16/20RG	12.27
ML16-STAR-SB20C/E	12.28
ML16-STAR-SR20J	12.30
ML16-STAR-SR20JII-A/B	12.31
ML16-STAR-SR-20R	12.29
ML16-STAR-SR-20R111	12.30
ML16-STAR-SR-20R1V-2T	12.32
ML16-STAR-SR-20R1V-6T	12.32
ML16-STAR-SR-32J	12.33
ML16-STAR-SV-12/20	12.34
ML16-STAR-SV-20R	12.35
ML16-STAR-SW-20R-2T	12.36
ML16-STAR-SW-20R-6T	12.36
ML16-SWISS-ST26-DUO	12.53
ML16-SWISS-ST26-JET	12.53
ML-AD	12.85
ML-FIX	12.82

Art. N°	Page
ML-JET	12.82
MS-HM	8.13
<b>P</b> POLYGONAL INTERFACE	1.153
<b>S</b> SC...	7.13
SD...	7.27
STARTER-KIT	16.12
SV...	7.45
<b>T</b> T216-L	5.04
T216L-EP	5.09
T216L-FT	5.06
T216L-GT	5.07
T216L-GTX	5.08
T216L-GX	5.05
T216-R	5.04
T216R-EP	5.09
T216R-FT	5.06
T216R-GT	5.07
T216R-GTX	5.08
T216R-GX	5.05
TM	10.38
TP55	10.36
TP60	10.34
<b>V</b> VCGT	7.52
VCGW	7.53
VGMT	7.58
<b>W</b> W750	1.149
W751-E	1.151
W760	1.149
W761-E	1.151



**PERFORMANCE | PRECISION | RIGIDITY**

**SWISSMADE**

**APPLITEC MOUTIER SA  
RUE INDUSTRIELLE 95  
2740 MOUTIER  
CH-SWITZERLAND**

**+41 (0)32 494 60 20  
INFO@APPLITEC-TOOLS.COM**

**WWW.APPLITEC-TOOLS.COM**